

Mazda Protegé

**1996
Workshop Manual**

MAZDA

WARNING

Servicing a vehicle can be dangerous. If you have not received service-related training, the risks of injury and property damage increase. The recommended servicing procedures for the vehicle in this workshop manual were developed with Mazda-trained technicians in mind. This manual may be useful to non-Mazda trained technicians, but a technician with our service-related training and experience will be at less risk when performing servicing operations. However, all users of this manual are expected to know general safety procedures.

This manual contains “Warnings” and “Cautions” applicable to risks not normally encountered in a general technician’s experience. They should be followed to reduce the risk of injury and the risk that improper service or repair may damage the vehicle or render it unsafe. It is also important to understand that the “Warnings” and “Cautions” are not exhaustive. It is impossible to warn of all the hazardous consequences that might result from failure to follow the procedures.

The procedures recommended and described in this manual are effective methods of performing service and repair. Some require tools specifically designed for a specific purpose. Nonrecommended procedures and tools should include consideration for safety of the technician and continued safe operation of the vehicle.

Parts should be replaced with genuine Mazda replacement parts, not parts of lesser quality. Use of a nonrecommended replacement part should include consideration for safety of the technician and continued safe operation of the vehicle.

1996 Mazda Protegé Workshop Manual

FOREWORD

A thorough familiarization with this manual is important for proper repair and maintenance. It should always be kept in a handy place for quick and easy reference.

The contents of this manual, including drawings and specifications, are the latest available at the time of printing. As modifications affecting repair or maintenance occur, relevant information supplementary to this volume will be made available at Mazda dealers. This manual should be kept up-to-date.

Mazda Motor Corporation reserves the right to alter the specifications and contents of this manual without obligation or advance notice.

All rights reserved. No part of this book may be reproduced or used in any form or by any means, electronic or mechanical—including photocopying and recording, and the use of any kind of information storage and retrieval system—without permission in writing.

WARRANTY

The manufacturer's warranty on Mazda vehicles and engines can be voided if improper service or repairs are performed by persons other than those at an Authorized Mazda Dealer.

**Mazda Motor Corporation
HIROSHIMA, JAPAN**

APPLICATION:

This manual is applicable to vehicles beginning with the Vehicle Identification Numbers (VIN), and related materials shown on the following page.

CONTENTS

Title		Section
General Information		GI
Engine	Z5	B1
	BP	B2
Lubrication System		D
Cooling System		E
Fuel and Emission Control Systems	Z5	F1
	BP	F2
Engine Electrical System		G
Clutch		H
Manual Transaxle	F25M-R	J
Automatic Transaxle	FA4A-EL	K
Front and Rear Axles		M
Steering System		N
Braking System		P
Wheels and Tires		Q
Suspension		R
Body	4SD	S1
Body Electrical System	4SD	T1
Heater and Air Conditioner Systems		U

© 1995 Mazda Motor Corporation
PRINTED IN U.S.A., JULY '95
Form No. 1495-10-95G
Part No. 9999-95-017B-96

VEHICLE IDENTIFICATION NUMBERS (VIN)

JM1 BB141*T0 300001—

JM1 BB142*T0 300001—

JM1 BB143*T0 300001—

JM1 BB144*T0 300001—

RELATED MATERIALS

1995 323/Protegé Service Highlights	9999-95-064F-95
1996 Protegé, MX-3, MX-5, 626/MX-6, 929, MPV, Millenia	
Service Highlights	9999-95-MODL-96
Engine Workshop Manual Z5-DOHC	9999-95-EWZ5-95
Engine Workshop Manual B6, BP-DOHC	9999-95-EWBP-95
Manual Transaxle Workshop Manual F25M-R	9999-95-F25M-95
Automatic Transaxle Workshop Manual FA4A-EL	9999-95-FA4A-95
1996 Protegé Wiring Diagram	9999-95-019G-96

GENERAL INFORMATION

SAFETY INFORMATION	GI- 2
LUBRICANTS	GI- 2
JACKING POSITIONS	GI- 2
SAFETY STAND POSITIONS	GI- 2
VEHICLE LIFT POSITIONS	GI- 3
DYNAMOMETER	GI- 3
COMPRESSED AIR	GI- 3
HOW TO USE THIS MANUAL	GI- 4
ADVISORY MESSAGES	GI- 4
PREPARATION	GI- 4
REPAIR PROCEDURE	GI- 4
SYMBOLS	GI- 5
IDENTIFICATION NUMBER LOCATIONS	GI- 6
ABBREVIATIONS	GI- 7
UNITS	GI- 8
SAE STANDARDS	GI- 9
FUNDAMENTAL PROCEDURES	GI-11
PROTECTION OF THE VEHICLE	GI-11
PREPARATION OF TOOLS AND MEASURING EQUIPMENT	GI-11
SPECIAL TOOLS	GI-11
REMOVAL OF PARTS	GI-11
DISASSEMBLY	GI-11
REASSEMBLY	GI-12
ADJUSTMENTS	GI-13
RUBBER PARTS AND TUBING	GI-13
HOSE CLAMPS	GI-13
TORQUE FORMULAS	GI-13
WISE	GI-13
ELECTRICAL TROUBLESHOOTING TOOLS ...	GI-14
TEST LIGHT	GI-14
JUMPER WIRE	GI-14
VOLTMETER	GI-14
OHMMETER	GI-14
ELECTRICAL PARTS	GI-15
BATTERY CABLE	GI-15
CONNECTORS	GI-15
TERMINALS	GI-16
SENSORS, SWITCHES, AND RELAYS	GI-16
WIRING HARNESS	GI-17
FUSE	GI-17
INSTALLATION OF RADIO SYSTEM	GI-17
TOWING	GI-18
PRE-DELIVERY INSPECTION	GI-19
PRE-DELIVERY INSPECTION TABLE	GI-19
SCHEDULED MAINTENANCE	GI-20
SCHEDULED MAINTENANCE TABLE (EXCEPT CANADA)	GI-20
SCHEDULED MAINTENANCE TABLE (CANADA)	GI-23

SAFETY INFORMATION

LUBRICANTS

Avoid prolonged and repeated contact with petroleum-based oils. Used oil may irritate the skin, and can cause skin cancer and other skin disorders.

Wash thoroughly after working with oil. We recommend water-soluble hand cleaners. Do not use kerosene, gasoline, or any other solvent to remove oil from your skin.

If repeated or prolonged contact with oil is necessary, wear protective clothing. Soiled clothing, particularly those soiled with used oils and greases containing lead, should be cleaned at regular intervals.

JACKING POSITIONS

Warning

- **Improperly jacking a vehicle is dangerous. The vehicle can slip off the jack and cause serious injury. Use only the correct front and rear jacking positions and block the wheels.**

Use safety stands to support the vehicle after it has been lifted.

Front

At the front of the engine mount member

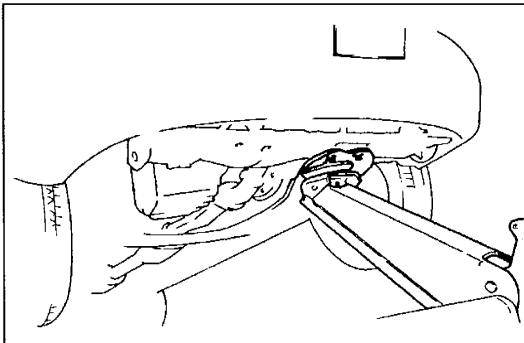

Rear

At the center of the crossmember

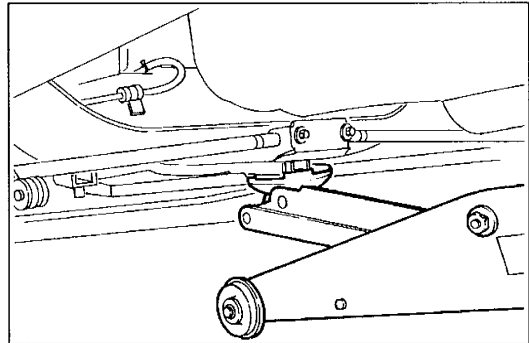

SAFETY STAND POSITIONS

Front

Both sides of the side sill

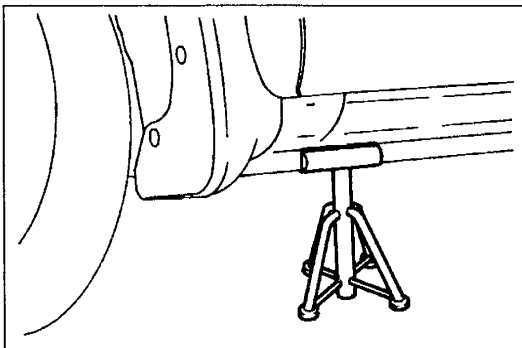

Rear

Both sides of the side sill

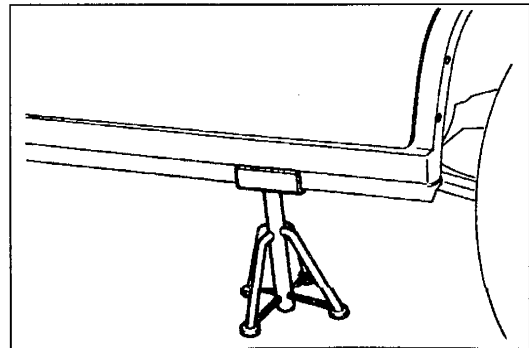

VEHICLE LIFT POSITIONS

GI

Front

Both sides of the side sill

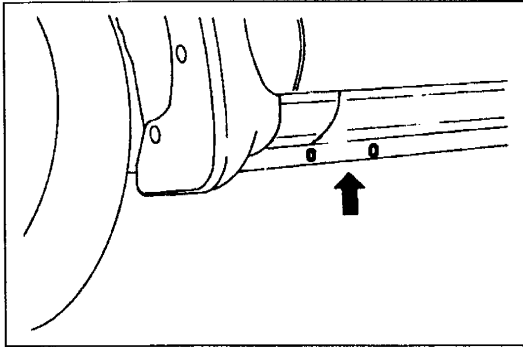
**Rear**

Both sides of the side sill

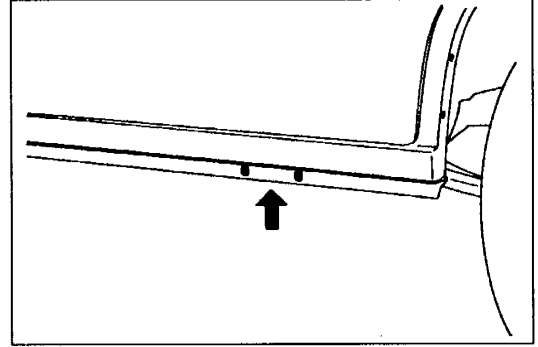
**DYNAMOMETER**

When test-running a vehicle on a dynamometer:

- Place a fan, preferably a vehicle-speed proportional type, in front of the vehicle.
- Connect an exhaust gas ventilation unit.
- Cool the exhaust pipes with a fan.
- Keep the area around the vehicle uncluttered.
- Watch the water temperature gauge.

COMPRESSED AIR

When using compressed air to clean or remove parts:

- Wear protective eye wear.
- Hold a rag over the opening to prevent parts from shooting out.
- Take precautions so that people around you are not struck by flying debris.

HOW TO USE THIS MANUAL

ADVISORY MESSAGES

You'll find several **Warnings**, **Cautions**, and **Notes** in this manual.

Warning

- A **Warning** indicates a situation in which serious injury or death could result if the warning is ignored.

Caution

- A **Caution** indicates a situation in which damage to the vehicle could result if the caution is ignored.

Note

- A **Note** provides added information that will help you to complete a particular procedure.

PREPARATION

This points out the needed **SSTs** for the service operation. It is best to gather all necessary **SSTs** before beginning work.

Example:

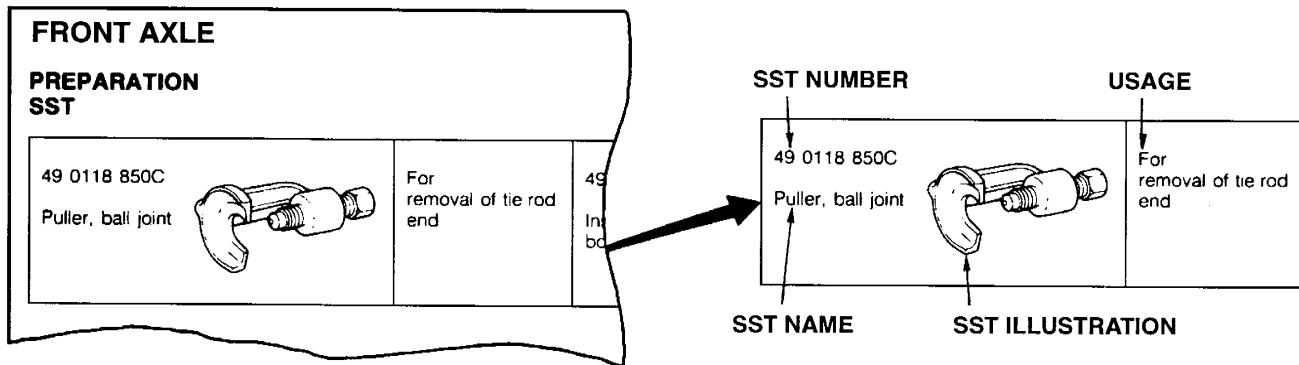

REPAIR PROCEDURE

1. Most repair operations begin with an overview illustration. It identifies the components, shows how the parts fit together, and describes visual part inspection. If a damaged or worn part is found, repair or replace it as necessary.
2. Expendable parts, tightening torques, and symbols for oil, grease, and sealant are shown in the overview illustration.
3. Pages related to service procedures are shown under the illustration. Refer to this information when servicing the related part.

Example:

SHOWS SPECIAL SERVICE TOOL (SST) FOR SERVICE OPERATION

SHOWS EXPENDABLE PARTS

SHOWS APPLICATION POINT OF OIL, ETC.

SHOWS RELATED PAGE FOR SERVICE

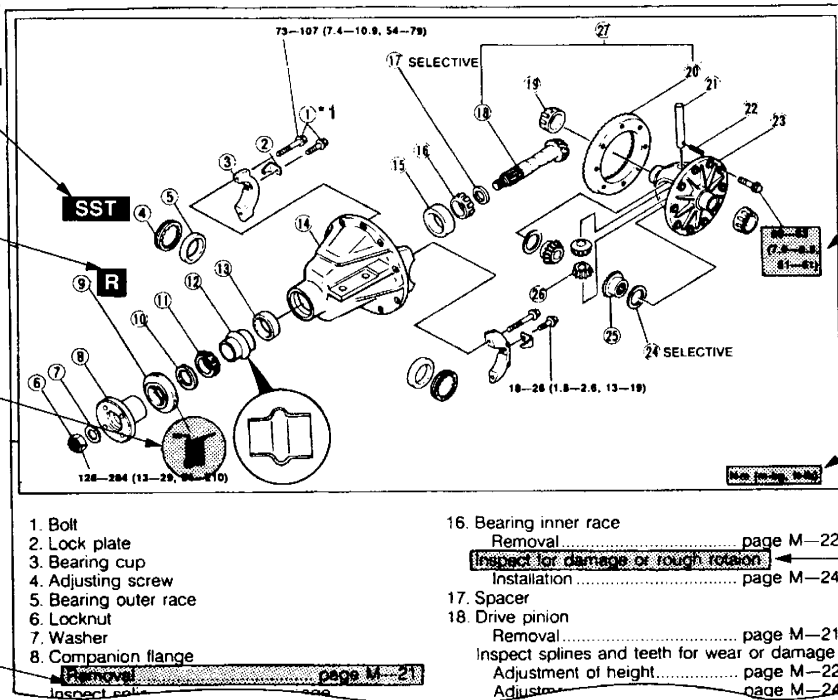

SHOWS TIGHTENING TORQUE SPECIFICATIONS

SHOWS TIGHTENING TORQUE UNITS

SHOWS VISUAL INSPECTION INFORMATION

*1: The numbers (①, etc.) refer to part identification and servicing procedures.

SYMBOLS

There are seven symbols indicating oil, grease, and sealant. These symbols show the points of applying such materials during service.

Symbol	Meaning	Kind
	Apply oil	New engine oil or gear oil as appropriate
	Apply brake fluid	FMVSS116: DOT-3
	Apply automatic transaxle fluid	M-III or Dexron®II
	Apply grease	Appropriate grease
	Apply sealant	Appropriate sealant
	Apply petroleum jelly	Appropriate petroleum jelly
	Replace part	O-ring, gasket, etc.

IDENTIFICATION NUMBER LOCATIONS

VEHICLE IDENTIFICATION NUMBER (VIN)

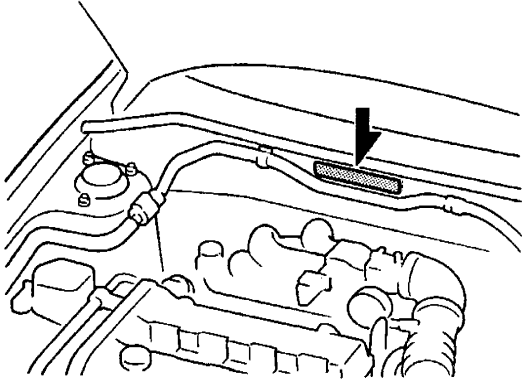

ENGINE MODEL AND NUMBER

Z5 ENGINE

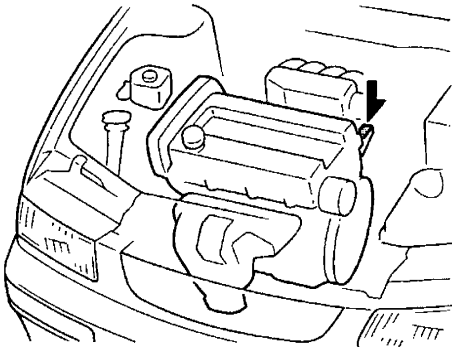

BP ENGINE

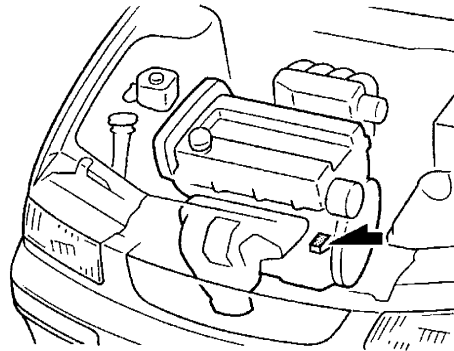

ABBREVIATIONS

ABDC	After bottom dead center
ABS	Antilock brake system
ACC	Accessory
ATDC	After top dead center
ATF	Automatic transaxle fluid
ATFT V	Transaxle fluid temperature signal voltage
ATX	Automatic transaxle
BAC	Bypass air control
BARO V	Barometric pressure signal voltage
BBDC	Before bottom dead center
BLR SW	Fan switch
BRK SW	Brake switch
BTDC	Before top dead center
CDCV	Canister drain cut valve
CM	Control module
CPU	Central processing unit
D	Drive
D SW	Transaxle range switch (D range)
DEF SW	Rear window defroster switch
DRL	Daytime running light
EC-AT	Electronically controlled automatic transaxle
ECT V	Engine coolant temperature signal voltage
EGR	Exhaust gas recirculation
EGRBV	EGR boost sensor solenoid valve
EGRP V	EGR valve position signal voltage
EGRVAC	EGR solenoid valve (vacuum) duty value
EGRVENT	EGR solenoid valve (vent) duty value
E/L	Electrical load
ELR	Emergency locking retractor
EX	Exhaust
FANC	Coolant fan control
FANN	Condenser fan control
FHO2S	Heated oxygen sensor (front)
FHO2SH	Heated oxygen sensor heater (front)
FTL V	Fuel tank level signal voltage
FTP	Fuel tank pressure
FTP V	Fuel tank pressure signal voltage
HDL SW	Headlight switch
HI	High
HLA	Hydraulic lash adjuster
HU	ABS hydraulic unit
IACV	Idle air control valve
IAT V	Intake air temperature signal voltage
IG	Ignition
IGT	Ignition timing
IN	Intake
INJ	Fuel injection duration
INJ#1	Fuel injector (cylinder No.1)
INT	Intermittent
LH	Left hand
LHD	Left hand drive
LO	Low
L SW	Transaxle range switch (L or 1 range)
M	Motor
MAF V	Mass air flow signal voltage
MTX	Manual transaxle
N	Neutral
NL SW	Neutral/clutch switch

O/D	Overdrive
O/DF LP	O/D OFF indicator light
O/DF SW	O/D OFF switch
OFF	Switch off
ON	Switch on
P	Park
PCV	Positive crankcase ventilation
PRC	Pressure regulator control
PRCV	PRC solenoid valve
PRGV	Purge solenoid valve
P/S	Power steering
P/W	Power window
R	Reverse
RH	Right hand
RHO2S	Heated oxygen sensor (rear)
RLY	Relay
RPM	Engine speed
SAS	Sophisticated air bag sensor
SHIFT A	Shift solenoid A
SHIFT B	Shift solenoid B
SHIFT C	Shift solenoid C
SST	Special service tool
S SW	Transaxle range switch (S or 2 range)
ST	Start
SW	Switch
TEN	TEN terminal (Data link connector)
TDC	Top dead center
TNS	Tail number side lights
TP V	Throttle position sensor signal voltage
TURBINE	Input/turbine speed sensor
VICS	Variable inertia charging system
VICSV	VICS solenoid valve
VRAS	Vibration reducing aluminum stiffener
VS	Vehicle speed
1GR	First gear
2GR	Second gear
4GR INH	4GR inhibit signal (cruise control unit)
4SD	4 Door Sedan

UNITS

Electrical current	A (ampere)
Electric potential	V (volt)
Electric power	W (watt)
Length	mm (millimeter) in (inch)
Negative pressure	kPa (kilo Pascal) mmHg (millimeters of mercury) inHg (inches of mercury)
Positive pressure	kPa (kilo Pascal) kgf/cm ² (kilogram force per square centimeter) psi (pounds per square inch)
Resistance	Ω (ohm)
Speed	RPM (revolution per minute)
Torque	N·m (Newton meter) kgf·m (kilogram force per meter) kgf·cm (kilogram force per centimeter) ft·lbf (foot pound) in·lbf (inch pound)
Volume	L (liter) US qt (U.S. quart) Imp qt (Imperial quart) ml (milliliter) cc (cubic centimeter) cu in (cubic inch) fl oz (fluid ounce)
Weight	g (gram) oz (ounce)

Conversion to SI Units (Système International d'Unités)

All numerical values in this manual are based on SI units. Numbers shown in conventional units are converted from these values.

Rounding off

Converted values are rounded off to the same number of places as the SI unit value. For example, if the SI unit value is 17.2 and the value after conversion is 37.84, the converted value will be rounded off to 37.8.

Upper and lower limits

When the data indicates upper and lower limits, the converted values are rounded down if the SI unit value is an upper limit and rounded up if the SI unit value is a lower limit. Therefore, converted values for the same SI unit value may differ after conversion. For example, consider 2.7 kgf/cm² in the following specifications:

- 210—260 kPa { 2.1—2.7 kgf/cm² , 30—38 psi }
- 270—310 kPa { 2.7—3.2 kgf/cm² , 39—45 psi }

The actual converted values for 2.7 kgf/cm² are 264 kPa and 38.4 psi. In the top specification, 2.7 is used as an upper limit, so its converted values are rounded down to 260 and 38. In the bottom specification, 2.7 is used as a lower limit, so its converted values are rounded up to 270 and 39.

SAE STANDARDS

In accordance with new regulations, SAE (Society of Automotive Engineers) standard names and abbreviations are now used in this manual. The table below lists the names and abbreviations that have been used in Mazda manuals up to now and their SAE equivalents.

Previous Standard		New Standard		
Abbreviation	Name	Abbreviation	Name	Remark
—	Accelerator Pedal	AP	Accelerator Pedal	
—	Air Cleaner	ACL	Air Cleaner	
—	Air Conditioning	A/C	Air Conditioning	
—	Airflow Meter	VAF	Volume Air Flow Sensor	
—	Airflow Sensor	MAF	Mass Air Flow Sensor	
—	Alternator	GEN	Generator	
—	ATF Thermosensor	—	Transmission (Transaxle) Fluid Temperature Sensor	
—	Atmospheric Pressure	BARO	Barometric Pressure	
VB	Battery Voltage	B+	Battery Positive Voltage	
—	Catalytic Converter	OC	Oxidation Catalytic Converter	
		TWC	Three-way Catalytic Converter	
		WU-TWC	Warm Up Three-way Catalytic Converter	#1
—	Circuit Opening Relay	FPR	Fuel Pump Relay	#2
—	Clutch Position	CPP	Clutch Pedal Position	
—	Crank Angle Sensor	CMP	Camshaft Position Sensor	
—	Crank Angle Sensor 2	CKP	Crankshaft Position Sensor	
—	Diagnosis Connector	DLC	Data Link Connector	
—	Diagnosis/Self-Diagnosis	OBD	On-Board Diagnostic	
—	Direct Ignition	DLI	Distributorless Ignition	
—	EC-AT Control Unit	TCM	Transmission (Transaxle) Control Module	
EGL	Electronic Gasoline Injection System	CIS	Continuous Fuel Injection System	
—	Electronic Spark Ignition	EI	Electronic Ignition	#3
ECU	Engine Control Unit	PCM	Powertrain Control Module	#4
		ECM	Engine Control Module	
—	Engine Modification	EM	Engine Modification	
—	Engine RPM Signal	—	Engine Speed Input Signal	
—	Evaporative Emission	EVAP	Evaporative Emission	
—	Exhaust Gas Recirculation	EGR	Exhaust Gas Recirculation	
—	Fan Control	FC	Fan Control	
—	Feedback System	CLS	Closed Loop System	
—	Flexible Fuel	FF	Flexible Fuel	
—	Fuel Pump	FP	Fuel Pump	
—	Fully Closed	CTP	Closed Throttle Position	
—	Fully Open	WOT	Wide Open Throttle	
—	Ground/Earth	GND	Ground	

#1: Directly connected to the exhaust manifold

#2: In some models, there is a fuel pump relay that controls pump speed. That relay is now called the fuel pump relay (speed).

#3: Controlled by the ECM (PCM)

#4: Device that controls the engine and powertrain

Previous Standard		New Standard		
Abbreviation	Name	Abbreviation	Name	Remark
—	IC Regulator	VR	Voltage Regulator	
—	Idle Speed Control	IAC	Idle Air Control	
—	Idle Switch	—	Closed Throttle Position Switch	
—	Igniter	ICM	Ignition Control Module	
—	Inhibitor Position	TR	Transmission (Transaxle) Range	
—	Intake Air Pressure	MAP	Manifold Absolute Pressure	
—	Intake Air Thermo	IAT	Intake Air Temperature	
—	Intercooler	CAC	Charge Air Cooler	
—	Knock Sensor	KS	Knock Sensor	
—	Line Pressure Solenoid Valve	—	Pressure Control Solenoid	
—	Lock-up Position	TCC	Torque Converter Clutch	
—	Malfunction Indicator Light	MIL	Malfunction Indicator Lamp	
—	Multipoint Fuel Injection	MFI	Multipoint Fuel Injection	
—	Open Loop	OL	Open Loop	
—	Overdrive	4GR	Fourth Gear	
—	Oxygen Sensor	HO2S	Heated Oxygen Sensor	With heater
		O2S	Oxygen Sensor	
—	Park/Neutral Range	PNP	Park/Neutral Position	
—	Power Steering Pressure	PSP	Power Steering Pressure	
—	Pulse Generator	—	Input/Turbine Speed Sensor	
—	Reed Valve	SAPV	Secondary Air Pulse Valve	
—	Secondary Air Injection System	PAIR	Pulsed Secondary Air Injection	Pulsed injection
		AIR	Secondary Air Injection	Inject with compressor
—	Sequential Fuel Injection	SFI	Sequential Multipoint Fuel Injection	
—	Service Code(s)	DTC	Diagnostic Trouble Code(s)	
—	Spark Ignition	DI	Distributor Ignition	
—	Stoplight Switch	—	Brake Switch	
—	Test Mode	DTM	Diagnostic Test Mode	#5
—	Throttle Body	TB	Throttle Body	
—	Throttle Sensor	TP	Throttle Position Sensor	
—	Turbocharger	TC	Turbocharger	
—	Vehicle Speed Sensor	VSS	Vehicle Speed Sensor	
—	Vehicle Speed Sensor 1	—	Output Speed Sensor	
—	Water Thermo	ECT	Engine Coolant Temperature	
—	1-2 Shift Solenoid Valve	—	Shift Solenoid A	
	Shift A Solenoid Valve			
—	2-3 Shift Solenoid Valve	—	Shift Solenoid B	
	Shift B Solenoid Valve			
—	3-4 Shift Solenoid Valve	—	Shift Solenoid C	
—	3rd Gear	3GR	Third Gear	
—	—	—	Incorrect Gear Ratio	

#5: Diagnostic trouble codes depend on the diagnostic test mode

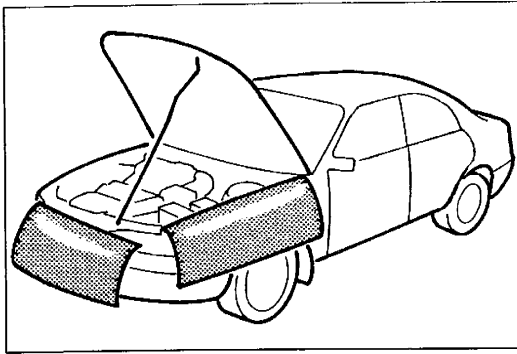

FUNDAMENTAL PROCEDURES

PROTECTION OF THE VEHICLE

Always be sure to cover fenders, seats, and floor areas before starting work.

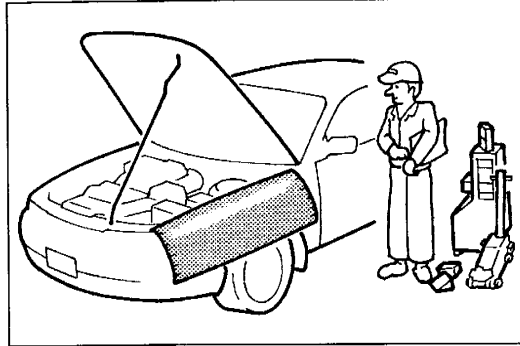

PREPARATION OF TOOLS AND MEASURING EQUIPMENT

Be sure that all necessary tools and measuring equipment are available before starting any work.

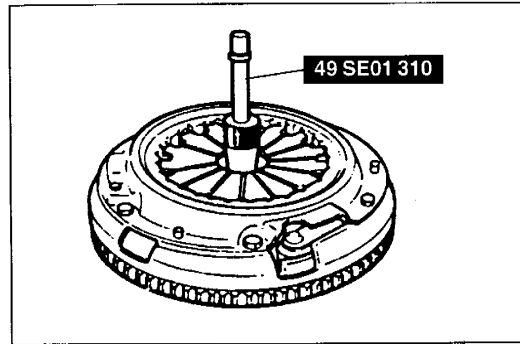

SPECIAL TOOLS

Use special tools when they are required.

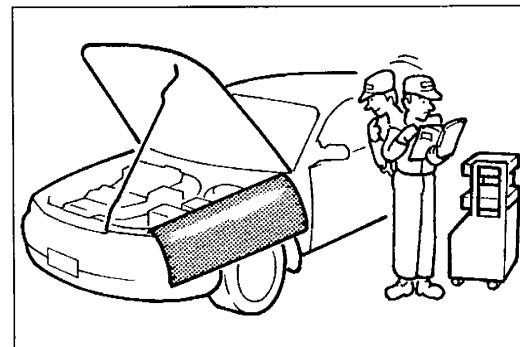

REMOVAL OF PARTS

While correcting a problem, try also to determine its cause. Begin work only after first learning which parts and subassemblies must be removed and disassembled for replacement or repair. After removing the part, plug all holes and ports to prevent foreign material from entering.

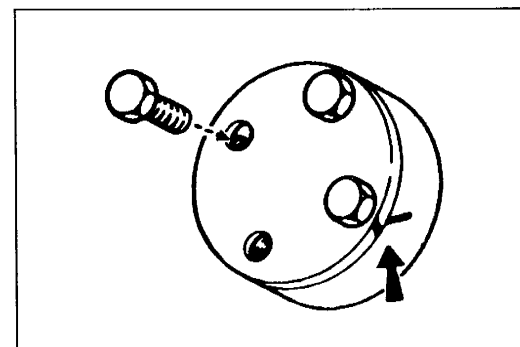

DISASSEMBLY

If the disassembly procedure is complex, requiring many parts to be disassembled, all parts should be disassembled in a way that will not affect their performance or external appearance and identified so that reassembly can be performed easily and efficiently.

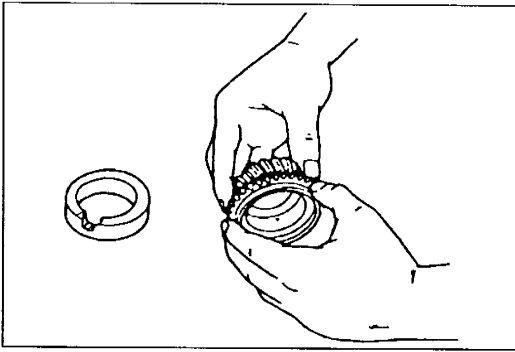

1. Inspection of parts

When removed, each part should be carefully inspected for malfunctioning, deformation, damage, and other problems.

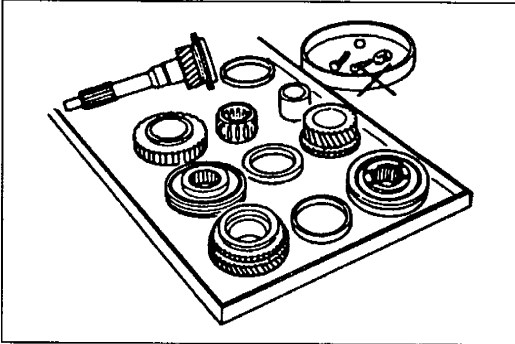

2. Arrangement of parts

All disassembled parts should be carefully arranged for reassembly.

Be sure to separate or otherwise identify the parts to be replaced from those that will be reused.

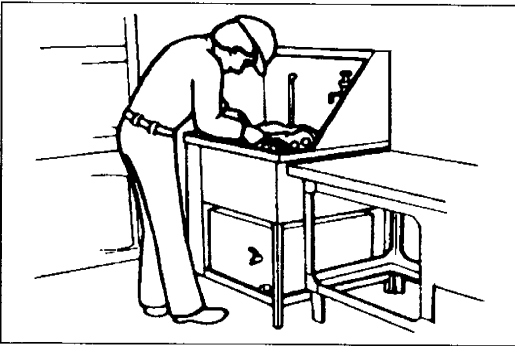

3. Cleaning parts for reuse

All parts to be reused should be carefully and thoroughly cleaned in the appropriate method.

Warning

- Using compressed air can cause dirt and other particles to fly out, causing injury to the eyes. Wear protective eye wear whenever using compressed air.

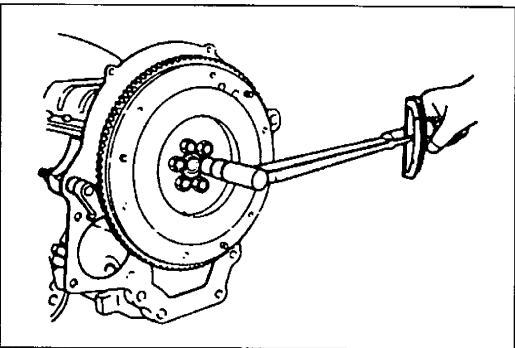

REASSEMBLY

Standard values, such as torques and certain adjustments, must be strictly observed in the reassembly of all parts.

If removed, these parts should be replaced with new ones:

- | | |
|----------------|-----------------|
| 1. Oil seals | 2. Gaskets |
| 3. O-rings | 4. Lock washers |
| 5. Cotter pins | 6. Nylon nuts |

Depending on location:

1. Sealant, gaskets, or both should be applied to the specified locations. When sealant is applied, parts should be installed before the sealant hardens. Hardened sealant causes leaks.
2. Oil should be applied to the moving components of parts.
3. Specified oil or grease should be applied at the prescribed locations (such as oil seals) before reassembly.

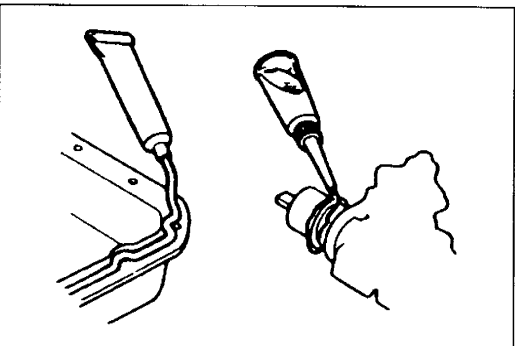

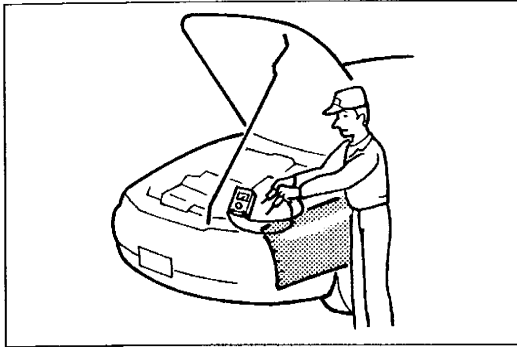

ADJUSTMENTS

Use suitable gauges and testers when making adjustments.

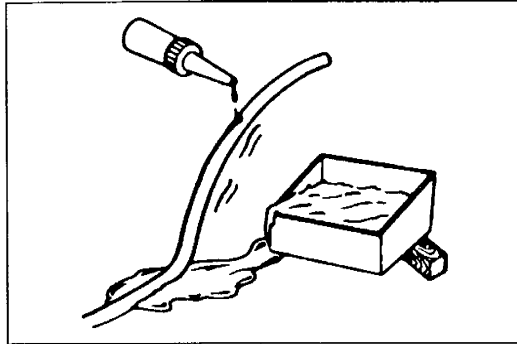

RUBBER PARTS AND TUBING

Prevent gasoline or oil from getting on rubber parts or tubing.

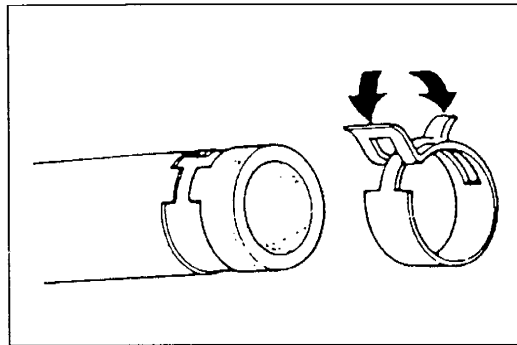

HOSE CLAMPS

When reinstalling, position the hose clamp in the original location on the hose, and squeeze the clamp lightly with large pliers to ensure a good fit.

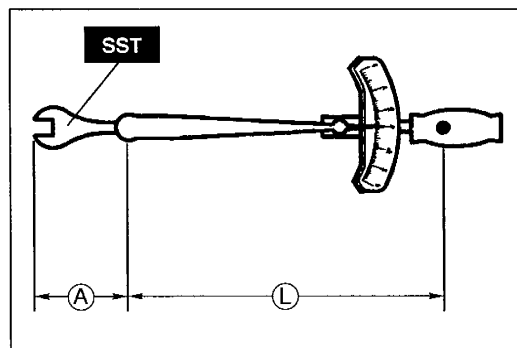

TORQUE FORMULAS

When using a torque wrench-SST combination, the written torque must be recalculated due to the extra length that the SST adds to the torque wrench. Recalculate the torque by using the following formulas. Choose the formula that applies to you.

Torque Unit	Formula
N·m	$N \cdot m \times [L / (L + A)]$
kgf·m	$kgf \cdot m \times [L / (L + A)]$
kgf·cm	$kgf \cdot cm \times [L / (L + A)]$
ft·lbf	$ft \cdot lbf \times [L / (L + A)]$
in·lbf	$in \cdot lbf \times [L / (L + A)]$

A = The length of the SST past the torque wrench drive.

L = The length of the torque wrench.

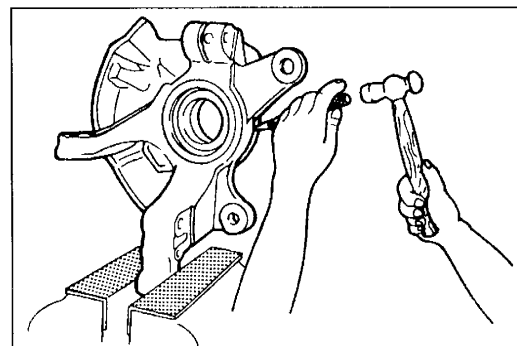

WISE

When using a vise, put protective plates in the jaws of the vise to prevent damage to parts.

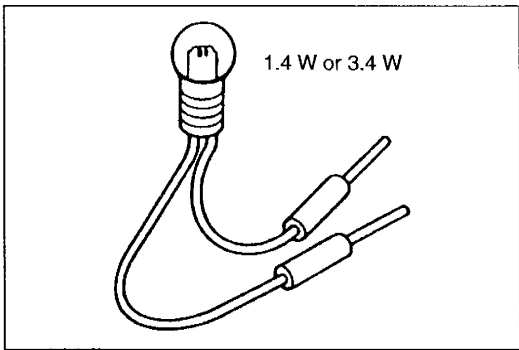

ELECTRICAL TROUBLESHOOTING TOOLS

TEST LIGHT

The test light, as shown in the figure, uses a 12 V bulb. The two lead wires should be connected to probes. The test light is used for simple voltage checks and for checking for short circuits.

Caution

- Using a bulb over 3.4 W when checking the control unit may damage the control unit.

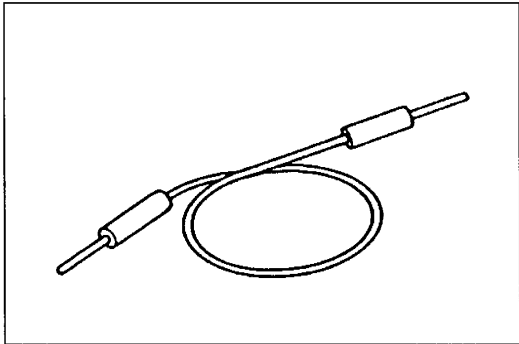

JUMPER WIRE

A jumper wire is used to create a temporary circuit. Connect the jumper wire between the terminals of a circuit to bypass a switch.

Caution

- Do not connect a jumper wire from the power source line to a body ground. This may cause burning or other damage to wiring harnesses or electronic components.

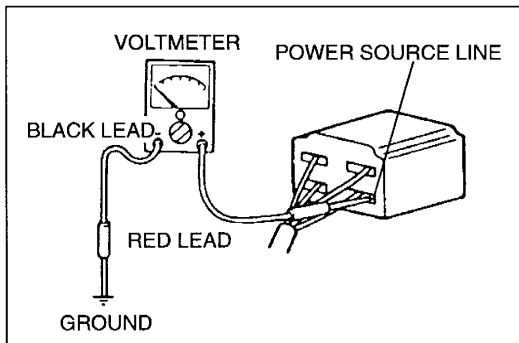

VOLTMETER

The DC voltmeter is used to measure circuit voltage. A voltmeter with a range of 15 V or more is used by connecting the positive (+) probe (red lead wire) to the point where voltage is to be measured and the negative (-) probe (black lead wire) to a body ground.

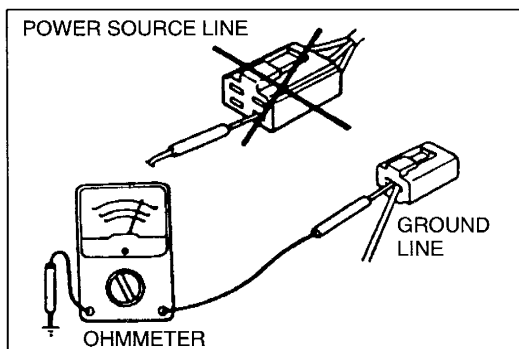

OHMMETER

The ohmmeter is used to measure the resistance between two points in a circuit, and to check for continuity and short circuits.

Caution

- Do not connect the ohmmeter to any circuit to which voltage is applied. This will damage the ohmmeter.

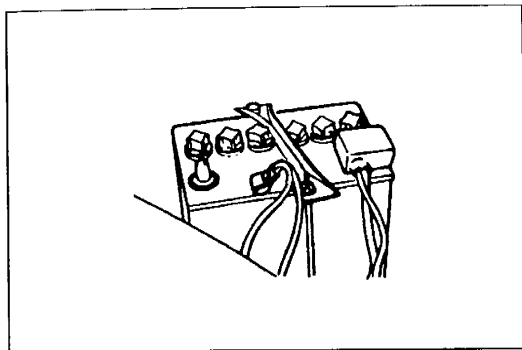

ELECTRICAL PARTS

BATTERY CABLE

Before disconnecting connectors or removing electrical parts, disconnect the negative battery cable.

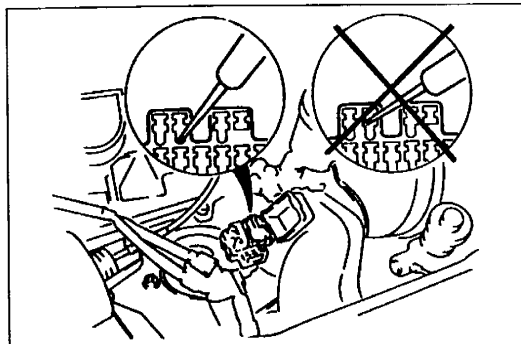

CONNECTORS

Data Link Connector

Insert the probe into the service hole when connecting a jumper wire to the data link connector.

Caution

- Inserting a jumper wire probe into the data link connector terminal may damage the terminal.

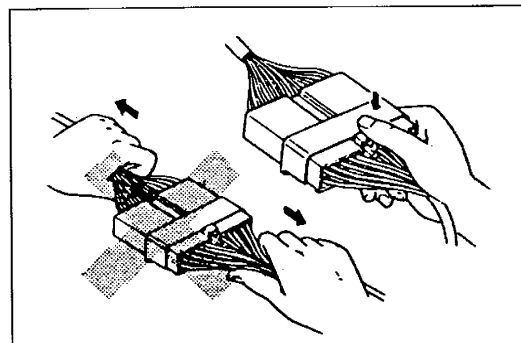

Disconnecting Connectors

When disconnecting two connectors, grasp the connectors, not the wires.

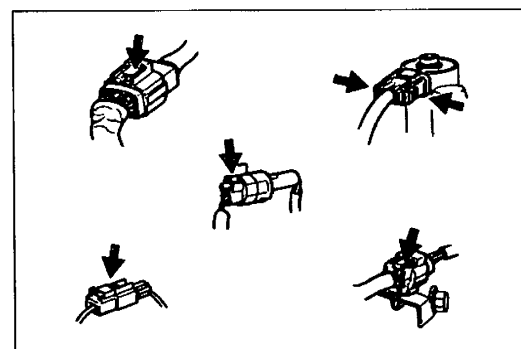

Connectors can be disconnected by pressing or pulling the lock lever as shown.

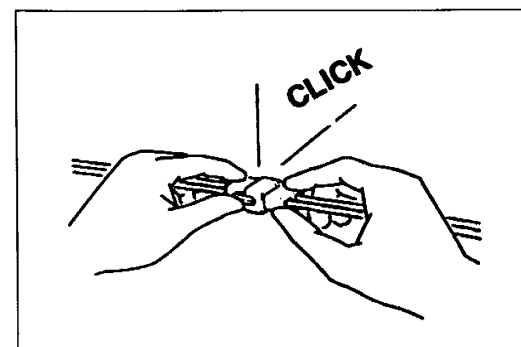

Locking Connector

When locking connectors, listen for a click that will indicate they are securely locked.

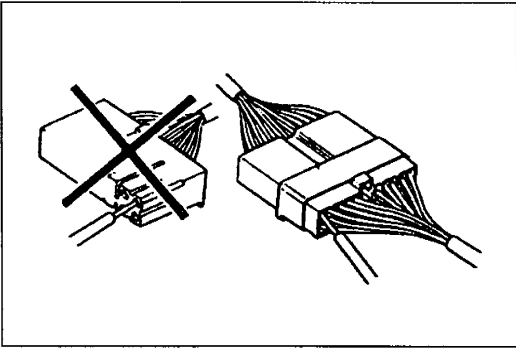

Inspection

1. When a tester is used to check for continuity or to measure voltage, insert the tester probe from the wiring harness side.

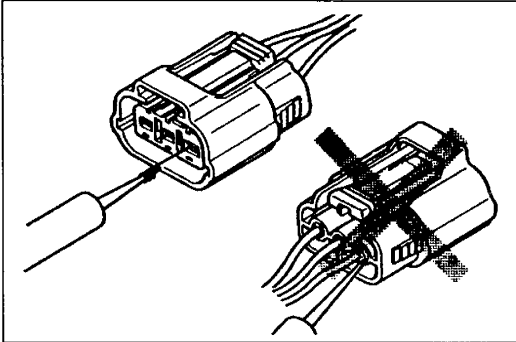

2. Check the terminals of waterproof connectors from the connector side, as they cannot be accessed from the wiring harness side.

Caution

- To prevent damage to the terminal, wrap a thin wire around the lead before inserting it into the terminal.

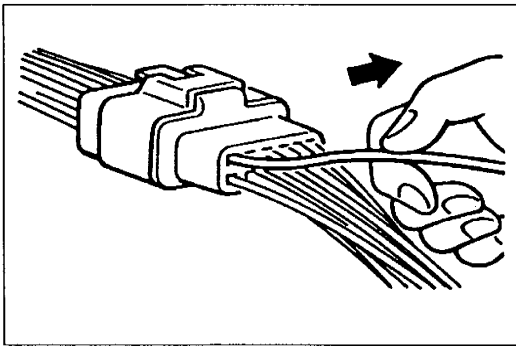

TERMINALS

Inspection

- Pull lightly on individual wires to check that they are secured in the terminal.

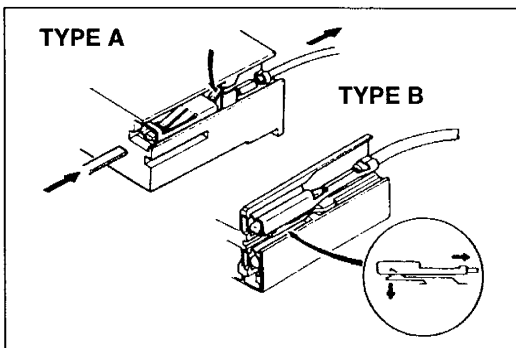

Replacement

Use the appropriate tools to remove a terminal as shown. When installing a terminal, be sure to insert it until it locks securely.

Insert a thin piece of metal from the terminal side of the connector, and then, with the terminal locking tab pressed down, pull the terminal out from the connector.

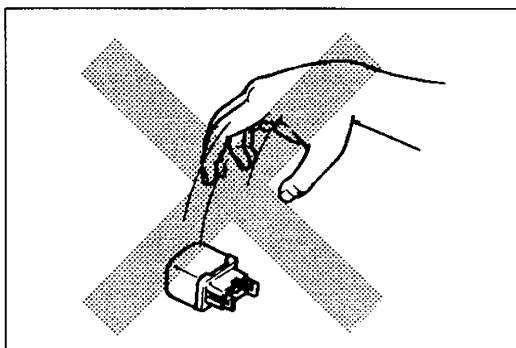

SENSORS, SWITCHES, AND RELAYS

Handle sensors, switches, and relays carefully. Do not drop them or strike them against other objects.

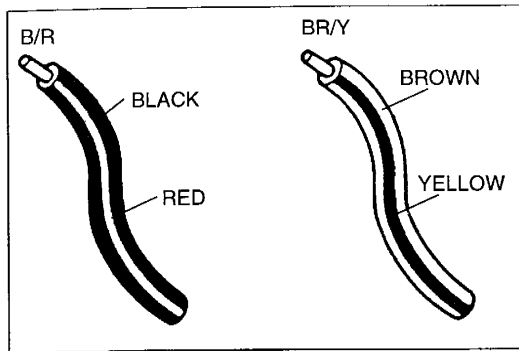

WIRING HARNESS

Wiring Color Codes

Two-color wires are indicated by a two-color code symbol.

The first letter indicates the base color of the wire and the second the color of the stripe.

CODE	COLOR	CODE	COLOR
B	Black	O	Orange
BR	Brown	P	Pink
G	Green	R	Red
GY	Gray	V	Violet
L	Blue	W	White
LB	Light Blue	Y	Yellow
LG	Light Green	—	—

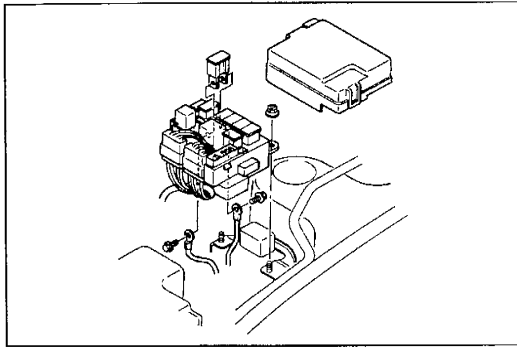

FUSE

Replacement

1. When replacing a fuse, be sure to replace it with one of the specified capacity.
If a fuse again fails after it has been replaced, the circuit probably has a short and the wiring should be checked.
2. Be sure the negative battery terminal is disconnected before replacing a main fuse.
3. When replacing a pullout fuse, use the fuse puller supplied in the fuse box cover.

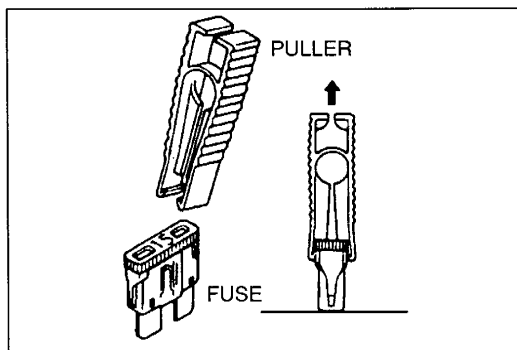

INSTALLATION OF RADIO SYSTEM

If a radio system is installed improperly or if a high-powered type is used, the CIS and other systems may be affected.

When the vehicle is to be equipped with a radio, observe the following precautions:

1. Install the antenna at the farthest point from control modules.
2. Install the antenna feeder as far as possible from the control module harnesses (**at least 30 cm { 11.8 in }**).
3. Ensure that the antenna and feeder are properly adjusted.
4. Do not install a high-powered radio system.

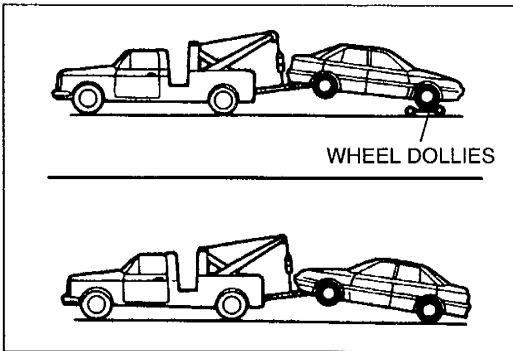

TOWING

Precautions

- Proper towing equipment is necessary to prevent damage to the vehicle.
- Laws and regulations applicable to vehicles in tow must always be observed.
- As a general rule, towed vehicles should be pulled with the driving wheels off the ground. If excessive damage or other conditions prevent towing the vehicle with the driving wheels off the ground, use wheel dollies.
- If all four wheels are on the ground, the vehicle may be towed only forward. Remember that power assist for the brakes and steering are not available when the engine is not running.

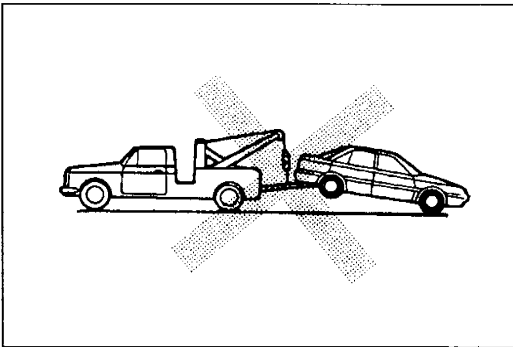

Procedure

With either automatic or manual transaxle:

1. Set the ignition switch in the ACC position.
2. Place the selector lever or shift lever in N (Neutral).
3. Release the parking brake.

Caution

- **Do not tow the vehicle backward with driving wheels on the ground. This may cause internal damage to the transaxle.**

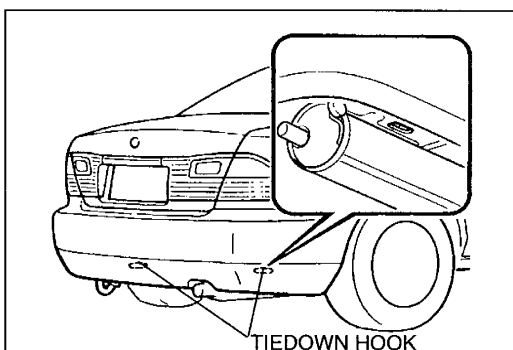
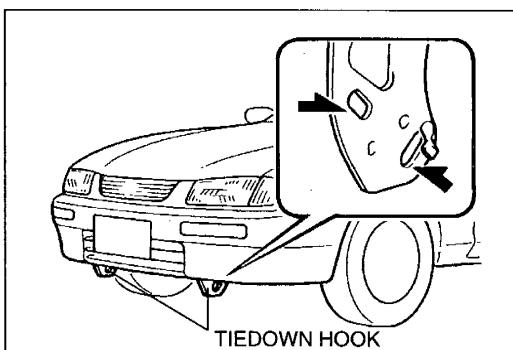

Caution

- **Don't use the tiedown hooks under the front and rear for towing. They are designed ONLY for tying down the vehicle when it's being transported. Using them for towing will damage the bumper.**

PRE-DELIVERY INSPECTION

PRE-DELIVERY INSPECTION TABLE

EXTERIOR

INSPECT and **ADJUST**, if necessary, the following items to specification:

- Glass, exterior bright metal, and paint for damage
- Wheel lug nuts
- Tire pressure
- All weatherstrips for damage or detachment
- Operation of hood release and lock
- Operation of fuel lid and trunk lid opener (if equipped)
- Door operation and alignment
- Headlight aiming

INSTALL the following parts:

- Wheel caps (if equipped)

UNDER HOOD—ENGINE OFF

INSPECT and **ADJUST**, if necessary, the following items to specification:

- Fuel, coolant, and hydraulic lines, fittings, connections, and components for leaks
- Engine oil level
- Power steering fluid level (if equipped)
- Brake and clutch fluid level
- Windshield washer reservoir fluid level
- Radiator coolant level and specific gravity
- Tightness of water hose clamps
- Tightness of battery terminals, electrolyte level, and specific gravity
- Manual transaxle oil level
- Drive belt(s) tension
- Accelerator cable and linkage for free movement

INTERIOR

INSTALL the following parts:

- Fuse for accessories

CHECK the operation of the following items:

- Seat controls (sliding and reclining) and headrest
- Air bag system using warning light
- Cruise set using indicator light (if equipped)
- Ignition switch and steering lock
- Power window (if equipped)
- Power door lock (if equipped)
- Door locks including child proof door locks
- Transaxle range switch (ATX only)
- All lights including warning and indicator lights
- Ignition key reminder buzzer (if equipped)
- Horn, wipers, and washers (front and rear, if equipped)

- Antenna
- Cigarette lighter and clock
- Power outside mirrors (if equipped)
- Heater, defogger, and air conditioner at various mode selections (if equipped)
- Sliding sunroof (if equipped)

CHECK the following items:

- Presence of spare fuse
- Upholstery and interior finish

CHECK and **ADJUST**, if necessary, the following items:

- Operation and fit of windows
- Pedal height and free play of brake and clutch pedal
- Parking brake

UNDER HOOD—ENGINE RUNNING AT OPERATING TEMPERATURE

CHECK the following items:

- Operation of idle-up system for electrical load, air conditioner or power steering (if equipped)
- Automatic transaxle fluid level
- Ignition timing
- Idle speed

ON HOIST

CHECK the following items:

- Underside fuel, coolant and hydraulic lines, fittings, connections, and components for leaks
- Tires for cuts or bruises
- Steering linkage, suspension, exhaust system, and all underside hardware for looseness or damage

ROAD TEST

CHECK the following items:

- Brake operation
- Clutch operation
- Steering control
- Operation of meters and gauges
- Squeaks, rattles, or unusual noises
- Engine general performance
- Emergency locking retractors

AFTER ROAD TEST

REMOVE the seat and floor mat protective covers

CHECK for the necessary owner information materials, tools, and spare tire in vehicle

SCHEDULED MAINTENANCE**SCHEDULED MAINTENANCE TABLE (EXCEPT CANADA)****Schedule 1 (Normal driving conditions)**

The vehicle is mainly operated where none of the “unique driving conditions” apply.

Schedule 2 (Unique driving conditions)

- Repeated short-distance driving.
- Driving in dusty conditions.
- Driving with extended use of brakes.
- Driving in areas where road salt or other corrosive materials are used.
- Driving on rough or muddy roads.
- Extended periods of idling or low-speed operation.
- Driving for long prolonged periods in cold temperatures or extremely humid climates.

Schedule 1 (Normal driving conditions)

Maintenance Interval Maintenance Item	Number of months or miles { kilometers }, whichever comes first									
	Months		6	12	18	24	30	36	42	48
	× 1000	Kilometers	12	24	36	48	60	72	84	96
	Miles	7.5	15	22.5	30	37.5	45	52.5	60	

Engine

Engine valve clearance (Z5 engine)										I
Engine oil	R	R	R	R	R	R	R	R	R	R
Oil filter	R	R	R	R	R	R	R	R	R	R
Tension of all drive belts				I						I
Engine timing belt (except California)	Replace every 60,000 miles { 96,000 km }									
Engine timing belt (California)	* ² Inspect at 60,000 miles { 96,000 km }, and again at 90,000 miles { 144,000 km }									
	Replace every 105,000 miles { 168,000 km }									
Hose and tube for emission										I* ²

Air cleaner

Air cleaner element					R					R
---------------------	--	--	--	--	---	--	--	--	--	---

Ignition system

Spark plugs					R					R
-------------	--	--	--	--	---	--	--	--	--	---

Fuel system

Idle speed					I* ²					I* ¹
Fuel filter										R* ¹
Fuel lines and hoses					I* ²					I* ¹
Fuel hose (California)	Inspect every 105,000 miles { 168,000 km }									

Cooling system

Cooling system					I					I
Engine coolant	Replace at first 45,000 miles { 72,000 km } or 36 months; after that, every 30,000 miles { 48,000 km } or 24 months									

Chassis and body

Brake lines, hoses, and connections					I					I
Disc brakes					I					I
Drum brakes					I					I
Steering operation and linkages					I					I
Front suspension ball joints					I					I
Drive shaft dust boots					I					I
Bolts and nuts on chassis and body					I					I
Exhaust system heat shield					I					I
All locks and hinges	L	L	L	L	L	L	L	L	L	L

Air conditioner system (if equipped)

Refrigerant amount			I		I		I			I
Compressor operation			I		I		I			I

Chart symbols:

- I : Inspect and repair, clean, or replace if necessary.
- R : Replace
- L : Lubricate

Remarks:

- After 48 months or 60,000 miles { 96,000 km }, continue to follow the described maintenance at the recommended intervals.
 - *¹ This maintenance is required for all states except California. However, we recommend that it also be performed on California vehicles.
 - *² This maintenance is recommended by Mazda. However, it is not necessary for emission warranty coverage or manufacturer recall liability.

Schedule 2 (Unique driving conditions)

Maintenance Interval	Number of months or miles { kilometers }, whichever comes first												
	Months	4	8	12	16	20	24	28	32	36	40	44	48
	× 1000	Kilometers	8	16	24	32	40	48	56	64	72	80	88
Maintenance Item	Miles	5	10	15	20	25	30	35	40	45	50	55	60

Engine

Engine valve clearance (Z5 engine)													I
Engine oil	R	R	R	R	R	R	R	R	R	R	R	R	R
Engine oil (Puerto Rico)	Replace every 3,000 miles { 4,800 km } (or 3 months)												
Oil filter	R	R	R	R	R	R	R	R	R	R	R	R	R
Tension of all drive belts						I							I
Engine timing belt (except California)	Replace every 60,000 miles { 96,000 km }												
Engine timing belt (California)	* ² Inspect at 60,000 miles { 96,000 km }, and again at 90,000 miles { 144,000 km }												
	Replace every 105,000 miles { 168,000 km }												
Hose and tube for emission													I* ²

Air cleaner

Air cleaner element			I* ²			R				I* ²			R
---------------------	--	--	-----------------	--	--	---	--	--	--	-----------------	--	--	---

Ignition system

Spark plugs						R							R
-------------	--	--	--	--	--	---	--	--	--	--	--	--	---

Cooling system

Cooling system						I							I
Engine coolant	Replace at first 45,000 miles { 72,000 km } or 36 months; after that, every 30,000 miles { 48,000 km } or 24 months												

Fuel system

Fuel filter													R* ¹
Fuel lines and hoses						I* ²							I* ¹
Idle speed						I* ²							I* ¹
Fuel hose (California)	Inspect every 105,000 miles { 168,000 km }												

Chassis and body

Brake lines, hoses, and connections								I					I
Drum brakes								I					I
Disc brakes			I					I		I			I
Steering operation and linkages								I					I
Front suspension ball joints								I					I
Drive shaft dust boots								I					I
Bolts and nuts on chassis and body			I					I		I			I
Exhaust system heat shield								I					I
All locks and hinges	L	L	L	L	L	L	L	L	L	L	L	L	L

Air conditioner system (if equipped)

Refrigerant amount			I					I					I
Compressor operation			I					I					I

Chart symbols:

- I : Inspect and repair, clean, or replace if necessary. (Inspect, and if necessary replace Air cleaner element only)
- R : Replace
- L : Lubricate

Remarks:

- After 48 months or 60,000 miles { 96,000 km }, continue to follow the described maintenance at the recommended intervals.
 - *¹ This maintenance is required for all states except California. However, we recommend that it also be performed on California vehicles.
 - *² This maintenance is recommended by Mazda. However, it is not necessary for emission warranty coverage or manufacturer recall liability.

SCHEDULED MAINTENANCE TABLE (CANADA)

Maintenance Interval Maintenance Item	Number of months or miles { kilometers }, whichever comes first													
	Months	5	10	15	20	25	30	35	40	45	50	55	60	
	× 1000 Kilometers	8	16	24	32	40	48	56	64	72	80	88	96	
	Miles	5	10	15	20	25	30	35	40	45	50	55	60	

Engine

Engine valve clearance (Z5 engine)														I
Engine oil	R	R	R	R	R	R	R	R	R	R	R	R	R	R
Oil filter	R	R	R	R	R	R	R	R	R	R	R	R	R	R
Tension of all drive belts	I	I	I	I	I	I	I	I	I	I	I	I	I	I
Engine timing belt*1														R

Air cleaner

Air cleaner element			I				R			I				R
---------------------	--	--	---	--	--	--	---	--	--	---	--	--	--	---

Ignition system

Spark plugs							R							R
-------------	--	--	--	--	--	--	---	--	--	--	--	--	--	---

Cooling system

Engine coolant level and strength	I	I	I	I	I	I	I	I	I	I	I	I	I	I
Cooling system for leaks			I				I			I				I
Engine coolant	Replace at first 45,000 miles { 72,000 km } or 45 months; after that, every 30,000 miles { 48,000 km } or 30 months													

Fuel system

Idle speed			I				I			I				I
Fuel lines and hoses							I*2							I
Fuel filter							R							R
PCV valve*2														I
Emission hoses and tubes														I

Chassis and body

Automatic transaxle fluid level	I	I	I	I	I	I	I	I	I	I	I	I	I	I
Transaxle oil (MTX and ATX)							R							R
Drive shaft dust boots							I							I
Brake lines and hoses							I							I
Brake and clutch fluid level	I	I	I	I	I	I	I	I	I	I	I	I	I	I
Brake fluid*3							R							R
Disc brakes (front and rear)			I				I			I				I
Rear drum brakes							I							I
Tire inflation pressure and tire wear	I	I	I	I	I	I	I	I	I	I	I	I	I	I
Tires			Rt				Rt			Rt				Rt
Power steering fluid level	I	I	I	I	I	I	I	I	I	I	I	I	I	I
Steering operation and linkages (Includes four wheel alignment)							I							I
Suspension components (front and rear)							I							I
All chassis and body nuts and bolts			I				I			I				I
Exhaust system heat shields							I							I
All locks and hinges	L	L	L	L	L	L	L	L	L	L	L	L	L	L
Washer fluid level	I	I	I	I	I	I	I	I	I	I	I	I	I	I
Function of all lights	I	I	I	I	I	I	I	I	I	I	I	I	I	I

Air conditioner system (if equipped)

Refrigerant amount		I		I			I			I			I	
Compressor operation		I		I			I			I			I	

Chart symbols:

- I** : Inspect and repair, clean, or replace if necessary. (Inspect, and if necessary replace ... Air cleaner element only)
- R** : Replace
- L** : Lubricate
- Rt** : Rotation (tires)

Remarks:

- After 60 months or 60,000 miles { 96,000 km }, continue to follow the described maintenance at the recommended intervals.
 - *1 Replacement of the timing belt is required every 60,000 miles { 96,000 km }. Failure to replace this belt may result in damage to the engine.
 - *2 This maintenance is recommended by Mazda. However, it is not necessary for emission warranty coverage or manufacturer recall liability.
 - *3 This maintenance operation is recommended by Mazda.

Before beginning any service procedure, refer to section T1 of this manual for air bag system service warnings.

ENGINE

(Z5)

DRIVE BELT	B1- 2
PREPARATION	B1- 2
INSPECTION / ADJUSTMENT	B1- 2
VALVE CLEARANCE	B1- 4
PREPARATION	B1- 4
INSPECTION / ADJUSTMENT	B1- 4
COMPRESSION	B1- 7
INSPECTION	B1- 7
TIMING BELT	B1- 8
PREPARATION	B1- 8
REMOVAL / INSTALLATION	B1- 8
CYLINDER HEAD GASKET	B1-14
PREPARATION	B1-14
REPLACEMENT	B1-14
FRONT OIL SEAL	B1-19
PREPARATION	B1-19
REPLACEMENT	B1-19
REAR OIL SEAL	B1-20
PREPARATION	B1-20
REPLACEMENT	B1-20
ENGINE	B1-21
PREPARATION	B1-21
REMOVAL / INSTALLATION	B1-21
DISASSEMBLY / ASSEMBLY	B1-28

DRIVE BELT

PREPARATION

SST

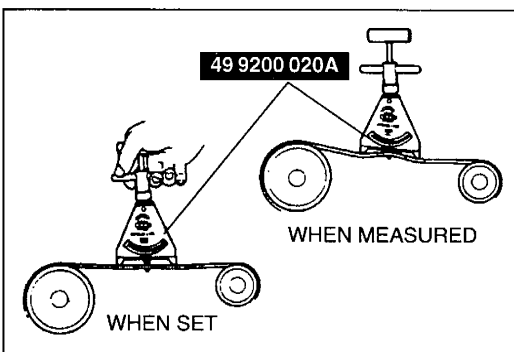
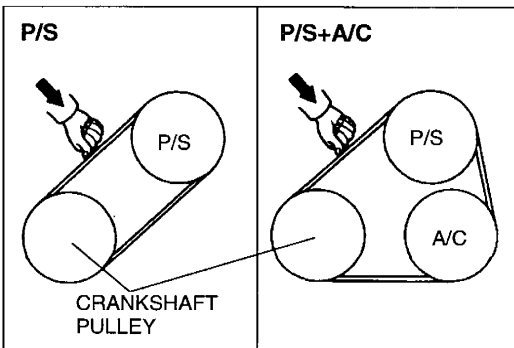
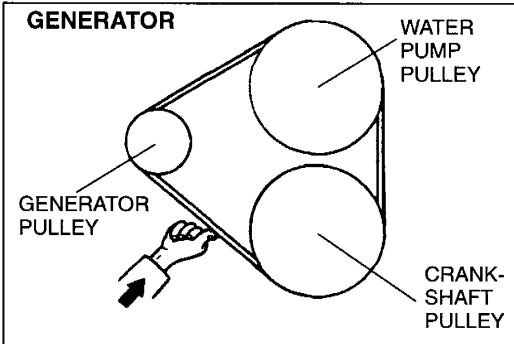
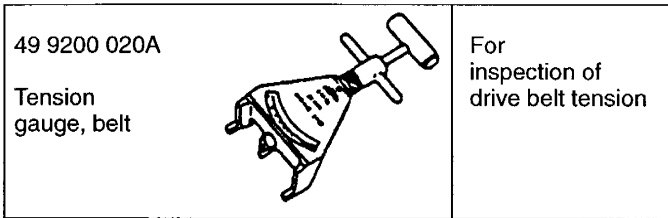

INSPECTION / ADJUSTMENT

Inspection

1. Check the drive belt deflection when the engine is cold, or at least 30 minutes after the engine has stopped. Apply moderate pressure **98 N { 10 kgf , 22 lbf }** midway between the specified pulleys.

Deflection

Drive belt	mm { in }		
	*New	Used	Limit
Generator	5.5—7.0 { 0.22—0.27 }	6.0—7.5 { 0.24—0.29 }	8.0 { 0.31 }
P/S, P/S+A/C	8.0—9.0 { 0.32—0.35 }	9.0—10.0 { 0.36—0.39 }	11.5 { 0.45 }

*A belt that has been on a running engine for less than five minutes.

2. If the deflection is not within the specification, adjust it. (Refer to page B1-3.)

Drive belt tension check

1. Belt tension can be checked in place of belt deflection. Check the drive belt tension when the engine is cold, or at least 30 minutes after the engine has stopped. Using the **SST**, check the belt tension between any two pulleys.

Tension

Drive belt	N { kgf , lbf }		
	*New	Used	Limit
Generator	500—740 { 50—76 , 110—160 }	500—700 { 50—72 , 110—150 }	340 { 35 , 77 }
P/S, P/S+ A/C	500—580 { 50—60 , 110—130 }	430—490 { 43—50 , 95—110 }	250 { 25 , 55 }

*A belt that has been on a running engine for less than five minutes.

2. If the tension is not within the specification, adjust it. (Refer to page B1-3.)

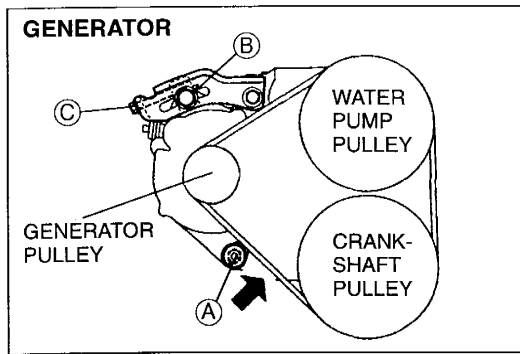

Adjustment
Generator drive belt

1. Loosen bolts (A) and (B).
2. Adjust the belt deflection by turning adjusting bolt (C).

B1

Deflection (At 98N { 10 kgf , 22 lbf })
New: 5.5—7.0 mm { 0.22—0.27 in }
Used: 6.0—7.5 mm { 0.24—0.29 in }

3. Tighten bolts (A) and (B).

Tightening torque

- (A): 38—51 N·m { 3.8—5.3 kgf·m , 28—38 ft·lbf }
- (B): 19—25 N·m { 1.9—2.6 kgf·m , 14—18 ft·lbf }

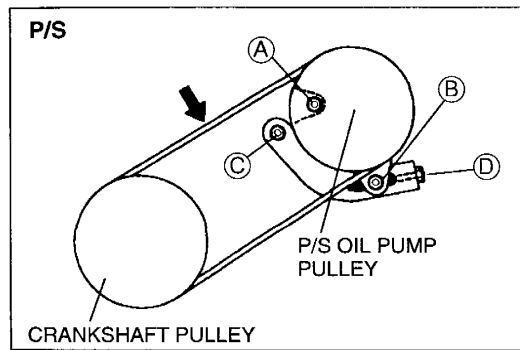

P/S, P/S + A/C drive belt

1. Loosen the bolts and nuts marked (A), (B) and (C).
2. Adjust the belt deflection by turning adjusting bolt (D).

Deflection (At 98 N { 10 kgf , 22 lbf })
New: 8.0—9.0 mm { 0.32—0.35 in }
Used: 9.0—10.0 mm { 0.36—0.39 in }

3. Tighten the bolts and nuts marked (A), (B) and (C).

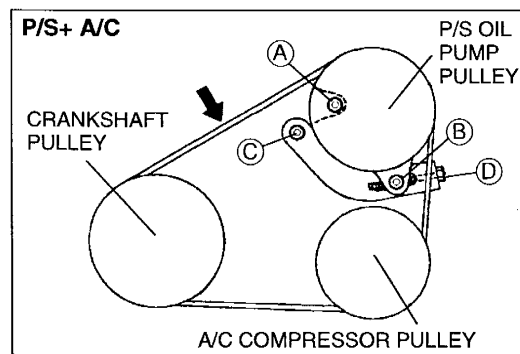

Tightening torque

- (A): 44—60 N·m { 4.4—6.2 kgf·m , 32—44 ft·lbf }
- (B): 38—51 N·m { 3.8—5.3 kgf·m , 28—38 ft·lbf }
- (C): 38—51 N·m { 3.8—5.3 kgf·m , 28—38 ft·lbf }

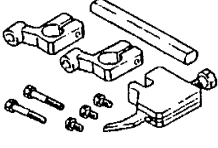
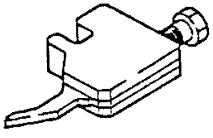

VALVE CLEARANCE

PREPARATION SST

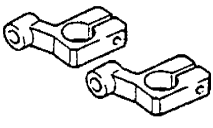
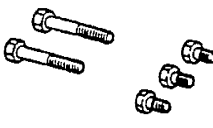
<p>49 T012 0A0 Holder, tappet</p> 	<p>For replacement of adjustment shim</p>	<p>49 T012 001 Body (Part of 49 T012 0A0)</p> 	<p>For replacement of adjustment shim</p>
<p>49 T012 002 Shaft (Part of 49 T012 0A0)</p> 	<p>For replacement of adjustment shim</p>	<p>49 T012 003 Clamp, shaft (Part of 49 T012 0A0)</p> 	<p>For replacement of adjustment shim</p>
<p>49 T012 004 Bolt (Part of 49 T012 0A0)</p> 	<p>For replacement of adjustment shim</p>	<p>—</p>	<p>—</p>

INSPECTION / ADJUSTMENT

Inspection

1. Remove the cylinder head cover.
2. Verify that the engine is in cold condition.
3. Measure the valve clearance.
 - (1) Turn the crankshaft clockwise so that the No.1 piston is at TDC of the compression stroke.
 - (2) Measure the valve clearance at (A) in the figure.

Standard (Engine cold)

IN: 0.25—0.31 mm { 0.010—0.012 in }
EX: 0.25—0.31 mm { 0.010—0.012 in }

- (3) If the valve clearance exceeds the standard, replace the adjustment shim. (Refer to page B1-5.)
- (4) Turn the crankshaft 360° clockwise so that the No.4 piston is at TDC of the compression stroke.
- (5) Measure the valve clearance at (B) in the figure.

Standard (Engine cold)

IN: 0.25—0.31 mm { 0.010—0.012 in }
EX: 0.25—0.31 mm { 0.010—0.012 in }

- (6) If the valve clearance exceeds the standard, replace the adjustment shim. (Refer to page B1-5.)
4. Install the cylinder head cover. (Refer to page B1-13.)

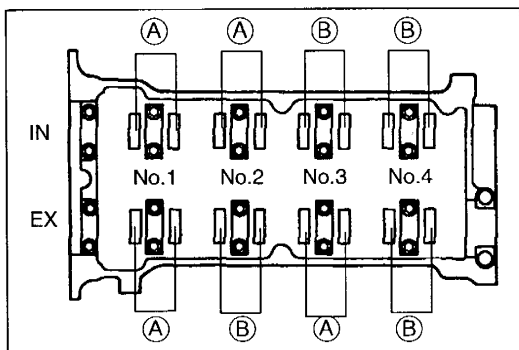
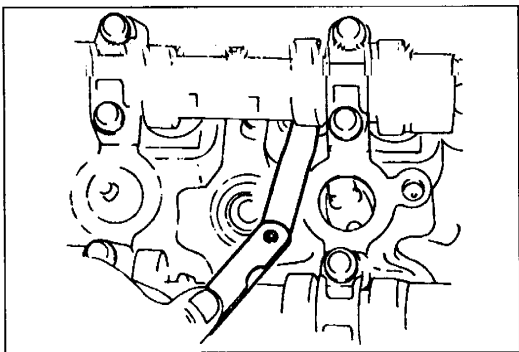

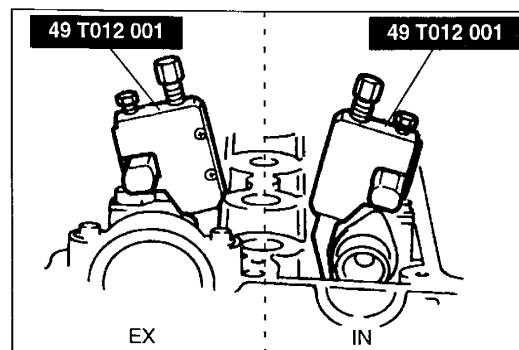
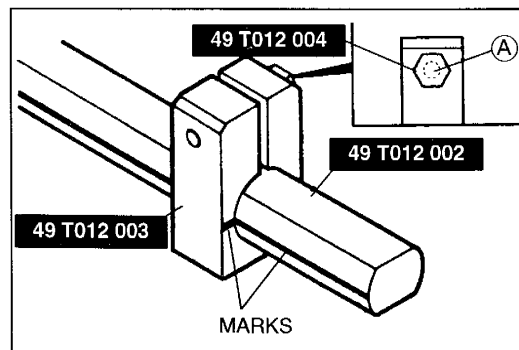
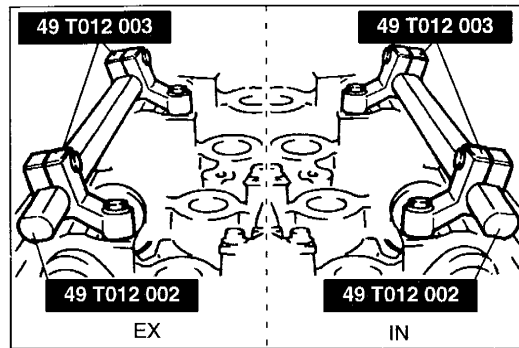
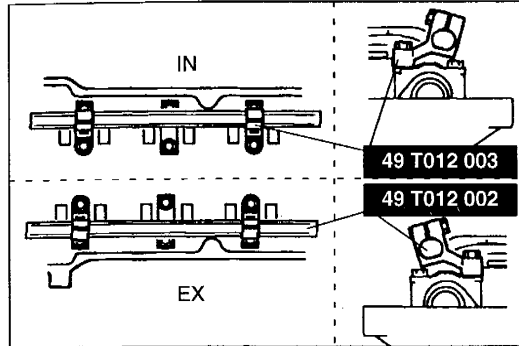
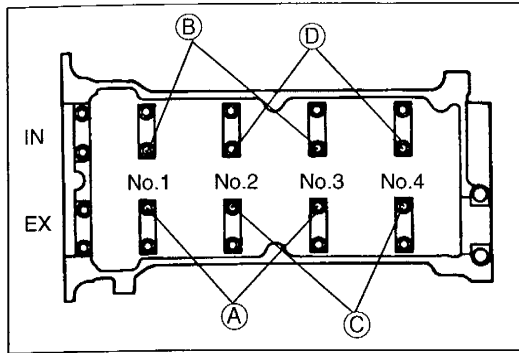

Adjustment

Perform this same procedure for all camshafts requiring valve clearance adjustment.

B1

1. Turn the crankshaft clockwise so that the cams on the camshaft requiring valve clearance adjustment are positioned straight up.
2. Remove the camshaft cap bolts as necessary.
 - Ⓐ: For EX side No.1, 2, 3 cylinder adjustment shim removal.
 - Ⓑ: For IN side No.1, 2, 3 cylinder adjustment shim removal.
 - Ⓒ: For EX side No.2, 3, 4 cylinder adjustment shim removal.
 - Ⓓ: For IN side No.2, 3, 4 cylinder adjustment shim removal.

Note

- For EX side No.2, 3 cylinder adjustment shim removal, remove bolts either Ⓐ or Ⓒ.
- For IN side No.2, 3 cylinder adjustment shim removal, remove bolts either Ⓑ or Ⓓ.

3. Install the **SSTs** on the camshaft using the camshaft cap bolt holes.

Tightening torque: 11.3—14.2 N·m
 { 115—145 kgf·cm , 99.9—125 in·lbf }

4. Align the marks on the **SSTs** (shaft and shaft clamp).
5. Tighten bolts Ⓐ to secure the **SST** (shaft).

6. Face the **SST** (body) toward the center of the cylinder head, and mount it on the **SST** (shaft) at the point of adjustment shim to be replaced.

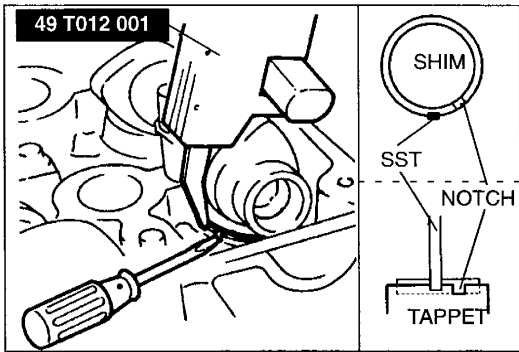

- Face the notch of the tappet so that a fine screwdriver can be inserted.

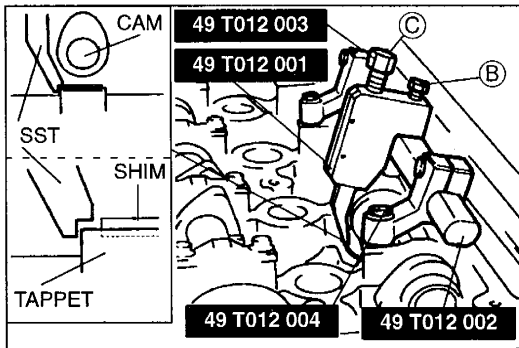

- Set the **SST** on the tappet by its notch.
- Tighten bolt **(B)** to secure the **SST** (body).

Caution

- Cylinder head can be damaged when the tappet is pressed down.

- Tighten bolt **(C)**, and press down the tappet.

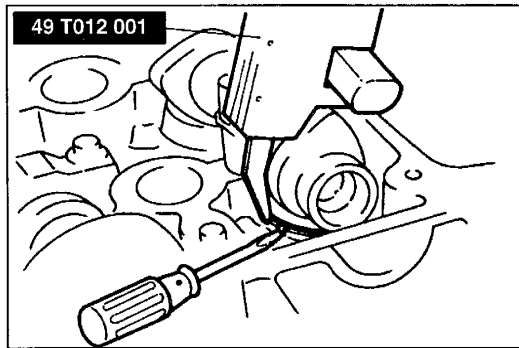

- Using a fine screwdriver, pry up the adjustment shim through the notch on the tappet. Remove the shim by using a magnet.
- Select proper adjustment shim.

New adjustment shim

$$= \text{Removed shim thickness} + \text{Measured valve clearance} - \text{Standard valve clearance (0.28 mm \{ 0.011 in \})}$$

- Push the selected shim into the tappet.
- Loosen bolt **(C)** to allow the tappet to move up.
- Loosen bolt **(B)** and remove the **SST** (body).
- Remove the **SSTs** and tighten the camshaft cap bolts.

Tightening torque: 11.3—14.2 N·m

$$\{ 115—145 \text{ kgf·cm} , 99.9—125 \text{ in·lbf} \}$$

- Check the valve clearance. (Refer to page B1-4.)

COMPRESSION

INSPECTION

B1

1. Verify that the battery is fully charged. Recharge it if necessary. (Refer to section G.)
2. Warm up the engine to the normal operating temperature.
3. Stop the engine and allow it to cool for about 10 minutes.
4. Remove the spark plugs.
5. Disconnect the distributor connectors.
6. Install a compression gauge into the No.1 spark plug hole.
7. Measure compression in the following procedure.
 - (1) Fully depress the accelerator pedal or fully open the throttle valve.
 - (2) Crank the engine and note the maximum gauge reading.

Compression

kPa { kgf/cm² , psi } –rpm

Standard	1344 { 13.7 , 195 } –300
Minimum	1010 { 10.3 , 146 } –300
Maximum difference between cylinders	196 kPa { 2.0 kgf/cm ² , 28 psi }





- (3) Check each cylinder as above.
- (4) If the compression in one or more cylinders is low, pour a small amount of clean engine oil into the cylinder and recheck the compression.
 - ① If the compression increases, the piston, piston rings, or cylinder wall may be worn.
 - ② If the compression stays low, a valve may be stuck or improperly seated.
 - ③ If the compression in adjacent cylinders stays low, the cylinder head gasket may be damaged or the cylinder head distorted.
8. Remove the compression gauge.
9. Connect the distributor connectors.
10. Install the spark plugs.

Tightening torque: 15—22 N·m { 1.5—2.3 kgf·m , 11—16 ft·lbf }

TIMING BELT

PREPARATION

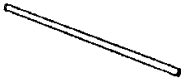
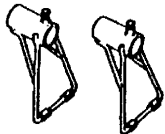
SST

<p>49 D011 102</p> <p>Lock tool, crankshaft</p> 	<p>For prevention of crankshaft rotation</p>	<p>49 G017 5A0</p> <p>Support, engine</p> 	<p>For support of engine</p>
<p>49 G017 501</p> <p>Bar (Part of 49 G017 5A0)</p> 	<p>For support of engine</p>	<p>49 G017 502</p> <p>Support (Part of 49 G017 5A0)</p> 	<p>For support of engine</p>
<p>49 G017 503</p> <p>Hook (Part of 49 G017 5A0)</p> 	<p>For support of engine</p>	<p>—</p>	<p>—</p>

REMOVAL / INSTALLATION

Caution

- The crankshaft position sensor rotor is on the rear of the crankshaft pulley, and can be damaged easily.

1. Disconnect the negative battery cable.
2. Remove the right front wheel.
3. Remove in the order shown in the figure, referring to **Removal Note**.
4. Install in the reverse order of removal, referring to **Installation Note**.
5. Install the right front wheel.
6. Connect the negative battery cable.
7. Start the engine and
 - (1) check the pulleys and the timing belt for runout and contact.
 - (2) check the ignition timing. (Refer to section F1.)

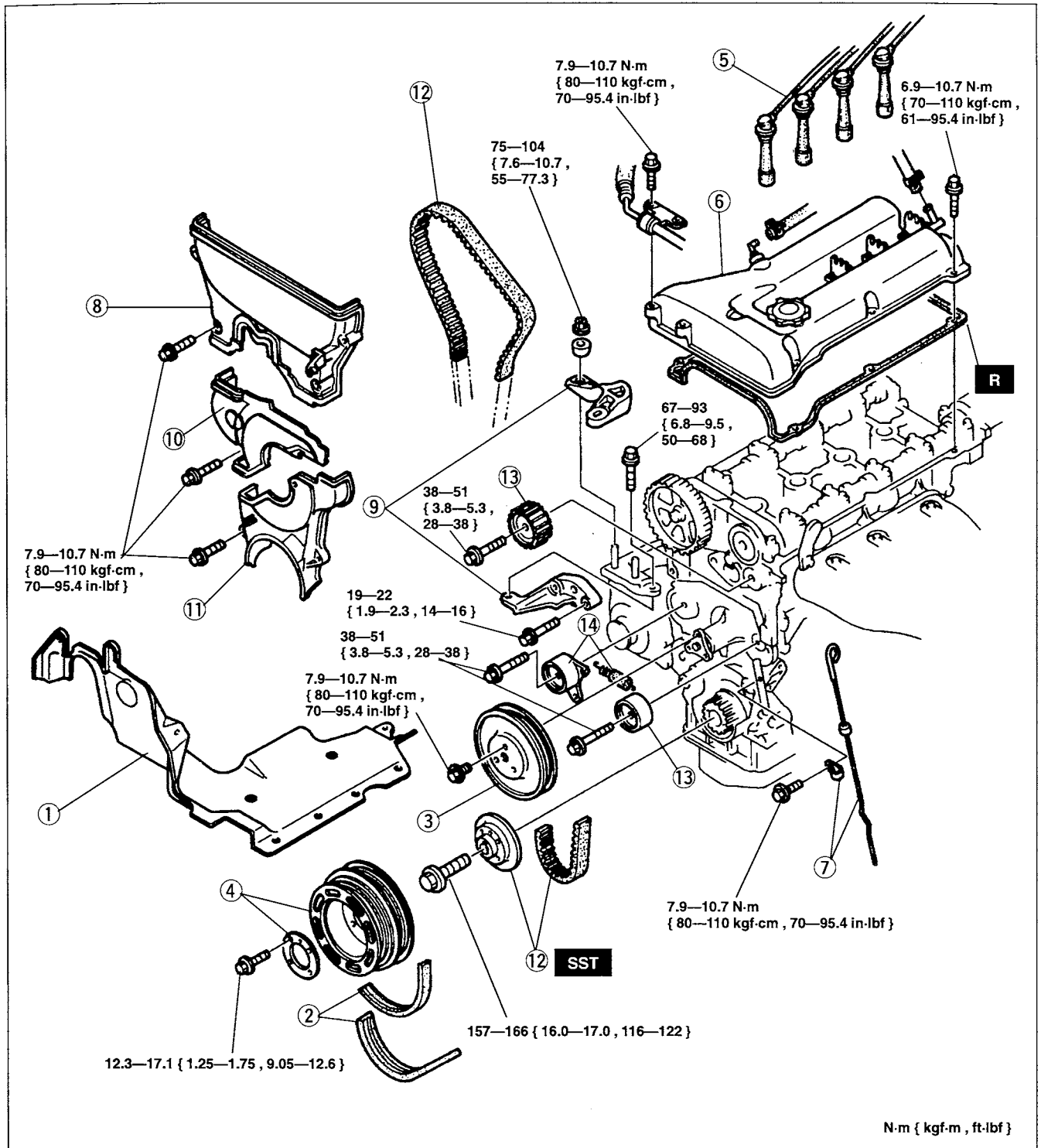

- | | |
|--|------------|
| 1. Splash shield (RH) | |
| 2. Drive belt | |
| Adjustment | page B1- 3 |
| 3. Water pump pulley | |
| 4. Crankshaft pulley | |
| 5. High-tension lead | |
| 6. Cylinder head cover | |
| Installation Note | page B1-13 |
| 7. Dipstick and pipe stay | |
| 8. Timing belt cover, upper | |
| 9. No.3 engine mount bracket | |
| Removal Note | page B1-10 |
| Installation Note | page B1-12 |
| 10. Timing belt cover, middle | |
| 11. Timing belt cover, lower | |
| 12. Pulley boss, timing belt | |
| Removal Note | page B1-10 |
| Installation Note | page B1-11 |
| 13. Idler pulley | |
| 14. Tensioner pulley, tensioner spring | |
| Installation Note | page B1-11 |

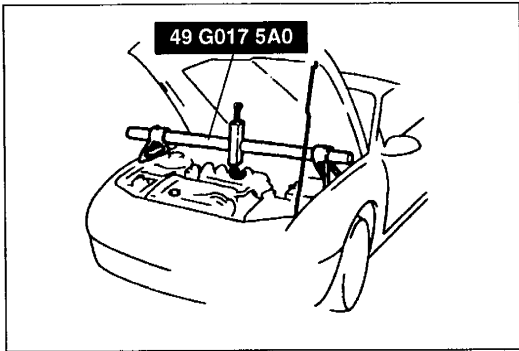

Removal Note

No.3 engine mount bracket

1. Support the engine by using the **SST**.
2. Remove the No.3 engine mount bracket.

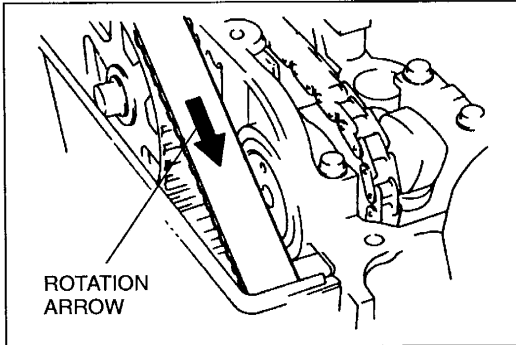

Pulley boss, timing belt

Note

- Mark the timing belt rotation on the belt for proper reinstallation.

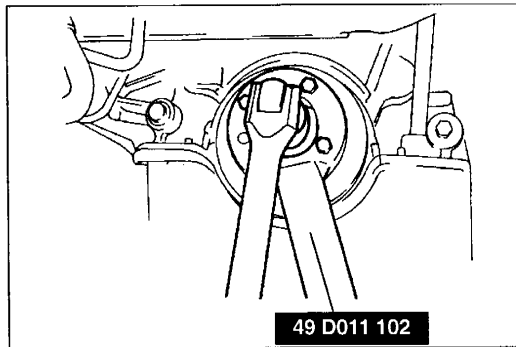

1. By using the **SST**, remove the pulley lock bolt.
2. Remove the pulley boss.

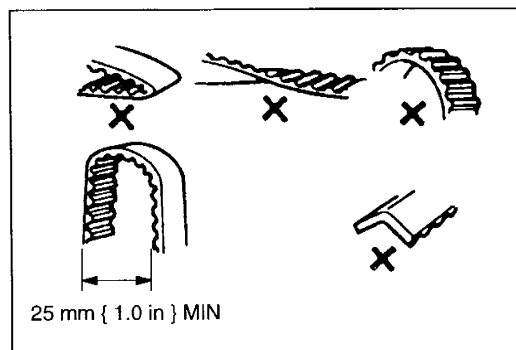

Caution

- The following will damage the belt and shorten its life; Forcefully twisting it, turning it inside out, or allowing oil or grease on it.

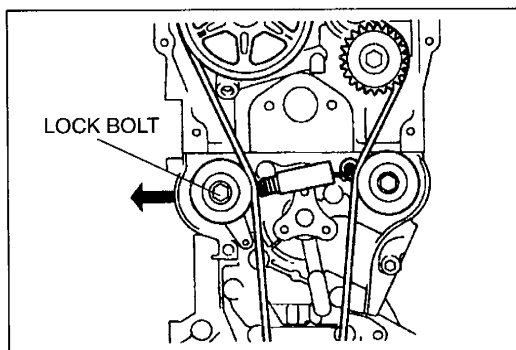

3. Loosen the tensioner pulley lock bolt.
4. Pull the tensioner pulley in the direction of the arrow to reduce tension of the timing belt, and remove the belt.

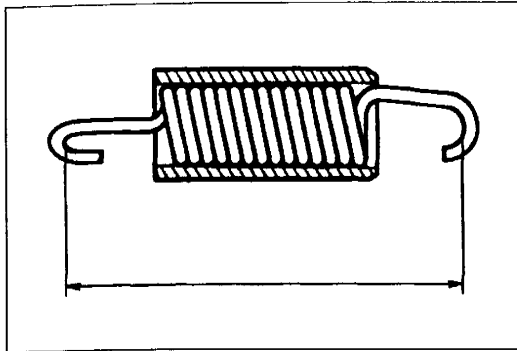
**Installation Note****Tensioner pulley, tensioner spring**

1. Measure the tensioner spring free length. If not within the specification, replace the tensioner spring.

Free length: 71.0 mm { 2.80 in }

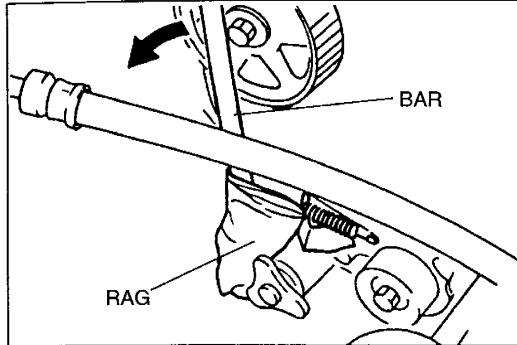

2. Install the tensioner and the tensioner spring.
3. Temporarily secure the tensioner with the spring fully extended.

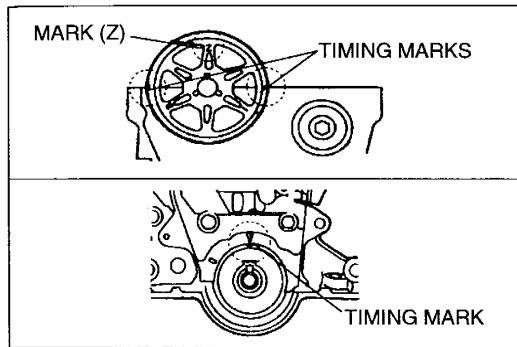
**Pulley boss, timing belt**

1. Verify that all timing marks are correctly aligned.

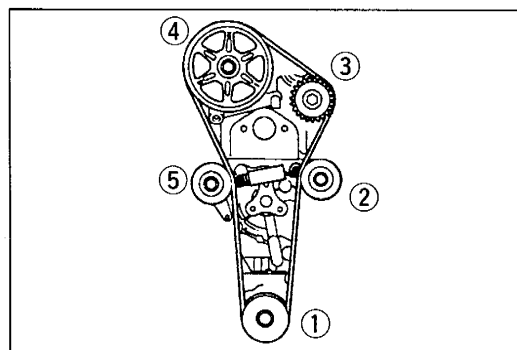

2. Install the timing belt on the pulleys in the order shown below.

- ① Timing belt pulley
- ② No.2 idler pulley
- ③ No.1 idler pulley
- ④ Camshaft pulley
- ⑤ Tensioner pulley

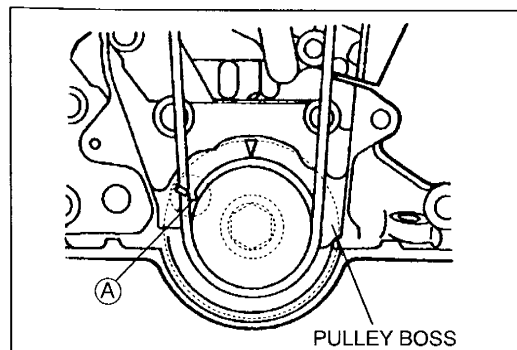

3. Install the pulley boss and pulley lock bolt. Turn the crankshaft clockwise 1 and 5/6 times, and verify that the timing mark on the timing belt pulley is aligned with timing mark **A** (tensioner set mark).

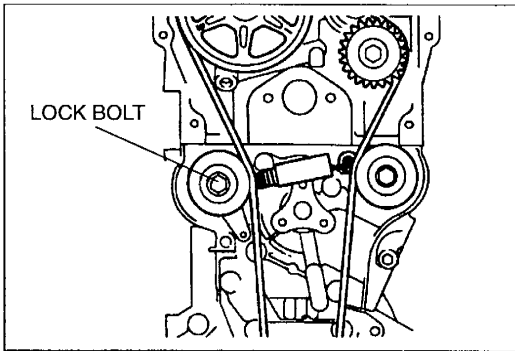

4. Loosen the tensioner lock bolt to apply tension to the timing belt. Do not apply tension other than that of the tensioner spring.
5. Tighten the tensioner pulley lock bolt.

Tightening torque:

38—51 N·m { 3.8—5.3 kgf·m , 28—38 ft·lbf }

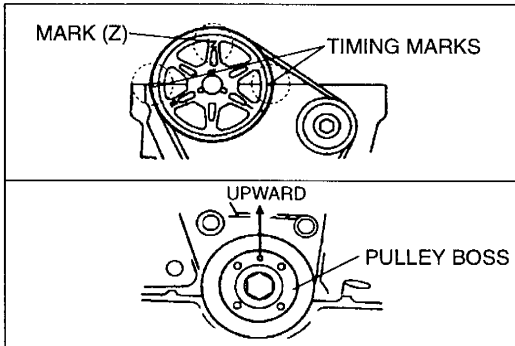

6. Turn the crankshaft 2 and 1/6 times clockwise, and verify that all timing marks are correctly aligned.

Note

- The pin on the pulley boss and the “Z” mark on the camshaft pulley must face upward.

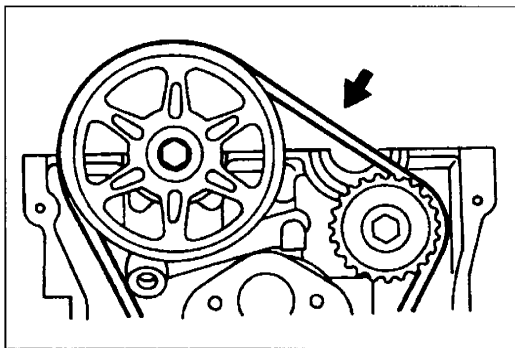

7. Check the belt deflection at the point indicated by applying moderate pressure **98 N { 10 kgf , 22 lbf }**.

Deflection: 7.0—9.0 mm { 0.28—0.35 in }

8. If the timing belt deflection is not correct, remove the timing belt and repeat from step 1.

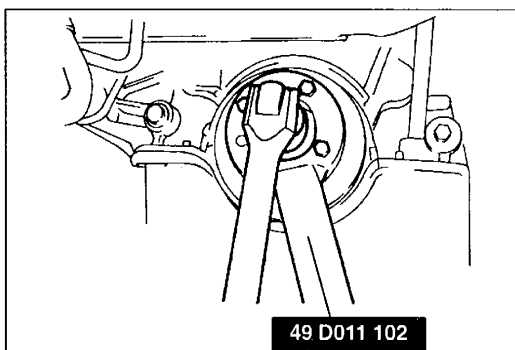

9. Mount the **SST** on the pulley boss to hold the crankshaft. Tighten the lock bolt.

Tightening torque:

157—166 N·m { 16.0—17.0 kgf·m , 116—122 ft·lbf }

10. Remove the **SST**.

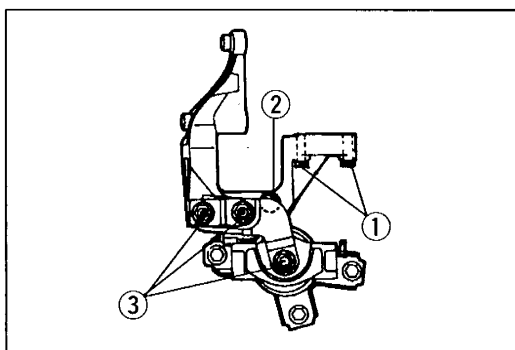

No.3 engine mount bracket

1. Install the No.3 engine mount bracket.

Tightening torque:

① **19—22 N·m { 1.9—2.3 kgf·m , 14—16 ft·lbf }**

② **67—93 N·m { 6.8—9.5 kgf·m , 50—68 ft·lbf }**

③ **75—104 N·m { 7.6—10.7 kgf·m , 55—77.3 ft·lbf }**

2. Remove the **SST** (Support, engine).

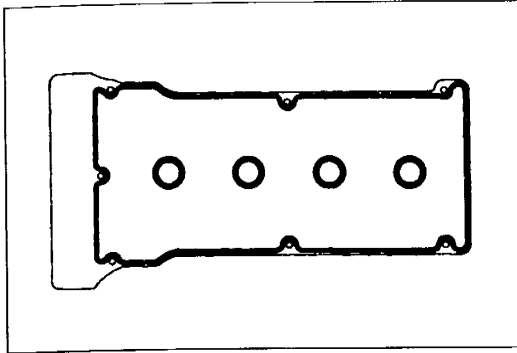
**Cylinder head cover**

1. Verify that the grooves on the cylinder head cover are free of oil, water and other foreign material.
2. Install the new cylinder head cover gasket into the cylinder head cover.

Caution

- Silicone sealant hardens and causes oil leakage when it is left for an extended period. Therefore, install parts before sealant hardens.

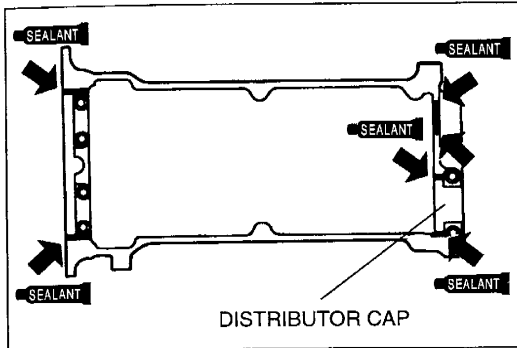

3. Apply silicone sealant to the shaded areas as shown.

Thickness: ϕ 3—4 mm { 0.12—0.15 in }

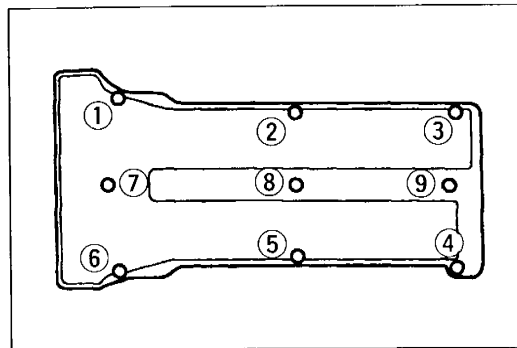

4. Install the cylinder head cover and tighten the bolts in five or six steps in the order shown.

Tightening torque:

6.9—10.7 N·m { 70—110 kgf·cm , 61—95.4 in·lbf }



5. Retighten the bolts in the order shown.

Tightening torque:

6.9—10.7 N·m { 70—110 kgf·cm , 61—95.4 in·lbf }

CYLINDER HEAD GASKET

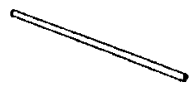
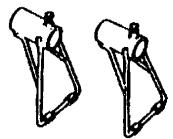
PREPARATION
SST

<p>49 G017 5A0</p> <p>Support, engine</p> 	<p>For support of engine</p>	<p>49 G017 501</p> <p>Bar (Part of 49 G017 5A0)</p> 	<p>For support of engine</p>
<p>49 G017 502</p> <p>Support (Part of 49 G017 5A0)</p> 	<p>For support of engine</p>	<p>49 G017 503</p> <p>Hook (Part of 49 G017 5A0)</p> 	<p>For support of engine</p>

REPLACEMENT

Warning

- **Fuel vapor is hazardous. It can very easily ignite, causing serious injury and damage. Always keep sparks and flames away from fuel.**
- **Fuel line spills and leaks are dangerous. Fuel can ignite and cause serious injuries or death and damage. Fuel can also irritate skin and eyes. To prevent this, always complete the "Fuel Line Safety Procedures" on section F1.**

1. Disconnect the negative battery cable.
2. Drain the engine coolant. (Refer to section E.)
3. Remove the timing belt. (Refer to page B1–8.)
4. Remove the air cleaner and front pipe. (Refer to section F1.)
5. Remove the exhaust manifold. (Refer to section F1.)
6. Remove in the order shown in the figure, referring to **Removal Note**.
7. Install in the reverse order of removal, referring to **Installation Note**.
8. Install the exhaust manifold. (Refer to section F1.)
9. Install the front pipe and air cleaner. (Refer to section F1.)
10. Install the timing belt. (Refer to page B1–8.)
11. Fill the radiator and radiator reservoir with the specified amount and type of engine coolant. (Refer to section E.)
12. Connect the negative battery cable.
13. Start the engine and
 - (1) check the engine oil and engine coolant leakage.
 - (2) check the ignition timing and idle speed. (Refer to section F1.)
14. Check the compression. (Refer to page B1–7.)

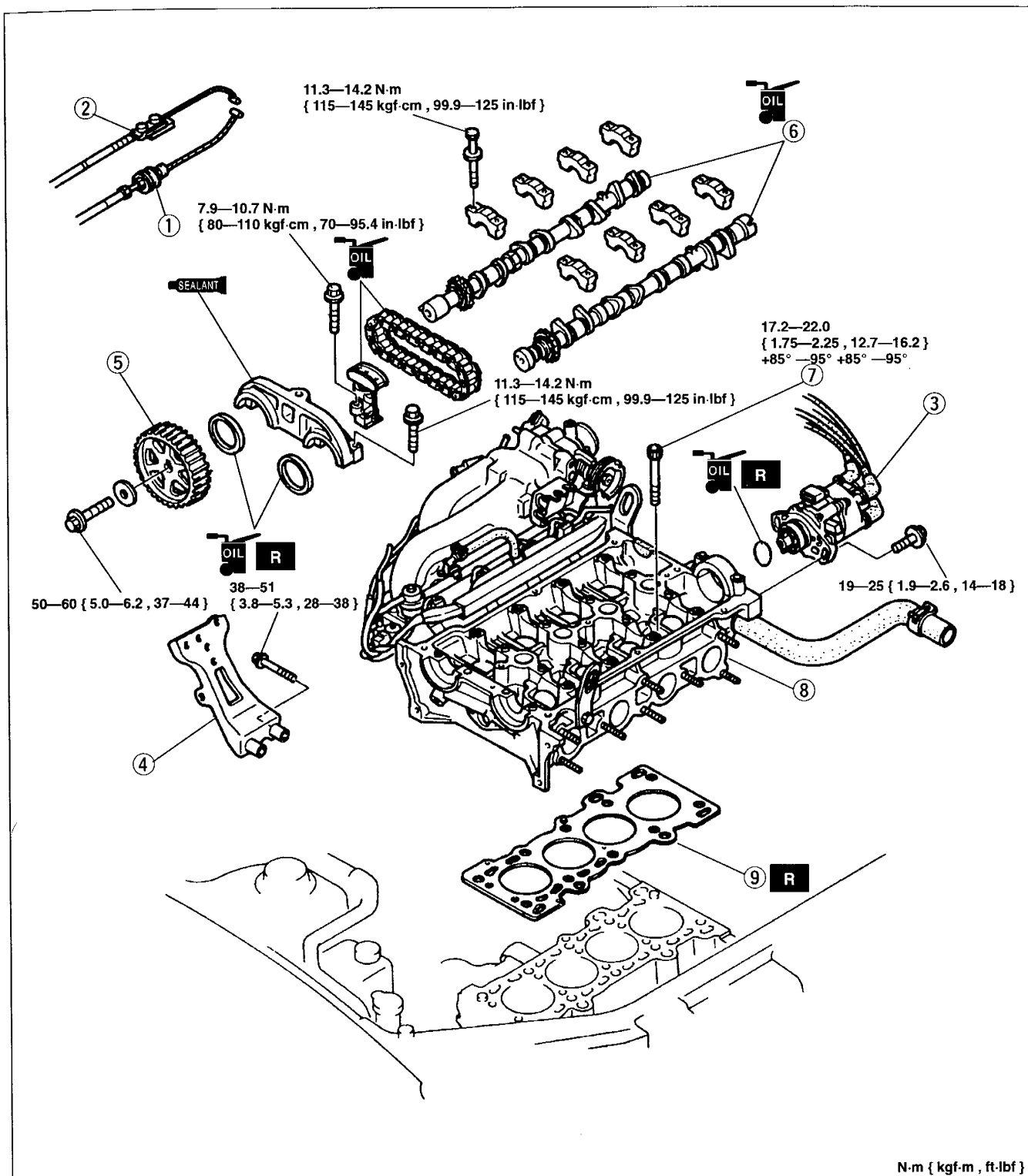

- 1. Accelerator cable
Adjustment section F1
- 2. Throttle cable (ATX)
Adjustment section K
- 3. Distributor
- 4. Intake manifold stay
- 5. Camshaft pulley
Removal Note page B1-16
Installation Note page B1-18

- 6. Camshaft
Removal Note page B1-16
Installation Note page B1-17
- 7. Cylinder head bolt
Removal Note page B1-16
Installation Note page B1-17
- 8. Cylinder head assembly
- 9. Cylinder head gasket

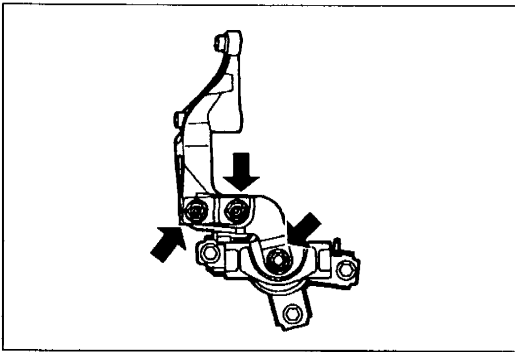

Removal Note

Camshaft pulley

1. Temporarily install the No.3 engine mount bracket to support the engine.
2. Remove the **SST** (Support, engine).

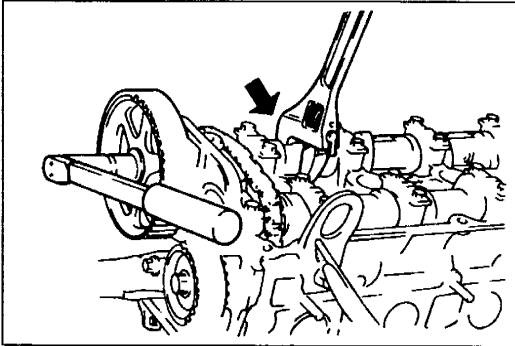

3. Hold the camshaft by using a wrench on the cast hexagon as shown, and loosen the camshaft pulley lock bolt.
4. Remove the camshaft pulley.

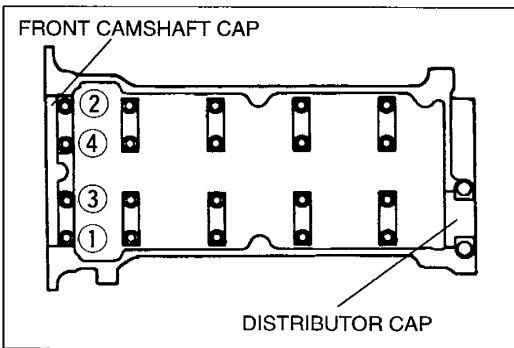

Camshaft

1. Turn the camshaft clockwise so that cams do not press on the tappets.
2. Loosen the front camshaft cap bolts in five or six steps in the order shown.
3. Remove the front camshaft cap bolts and the front camshaft cap.

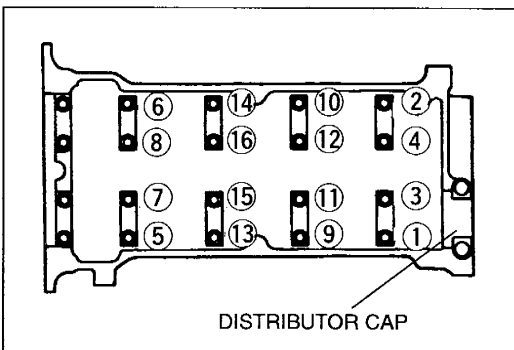

4. Loosen the camshaft cap bolts in five or six steps in the order shown.
5. Remove the camshaft cap bolts and camshaft caps.
6. Remove the camshafts.
7. Remove the camshaft oil seals.

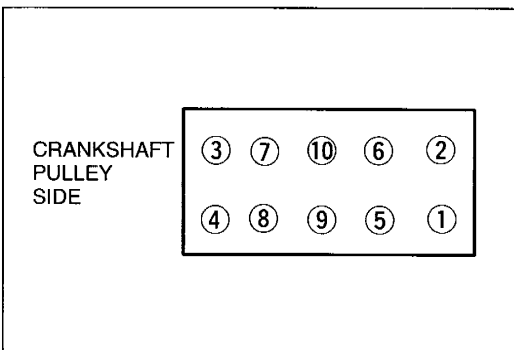

Cylinder head bolt

1. Loosen the cylinder head bolts in two or three steps in the order shown.
2. Remove the cylinder head bolts.

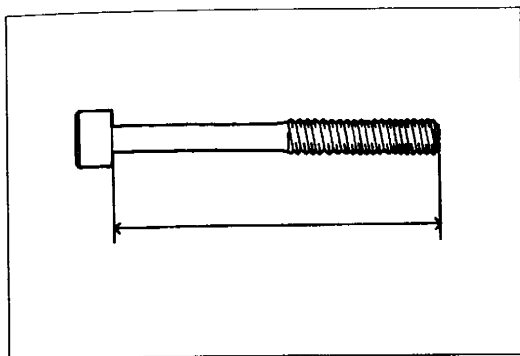

Installation Note

Cylinder head bolt

1. Before installation, measure the length of each bolt. Replace any that exceed the maximum length.

Length: 99.2—99.8 mm { 3.91—3.92 in }

Maximum: 100.5 mm { 3.957 in }

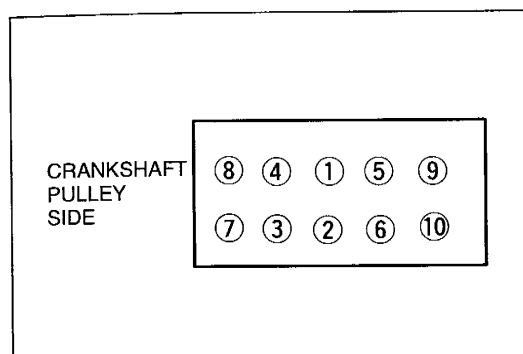

2. Tighten the cylinder head bolts in two or three steps in the order shown.

Tightening torque: 17.2—22.0 N·m
{ 1.75—2.25 kgf·m , 12.7—16.2 ft·lbf }

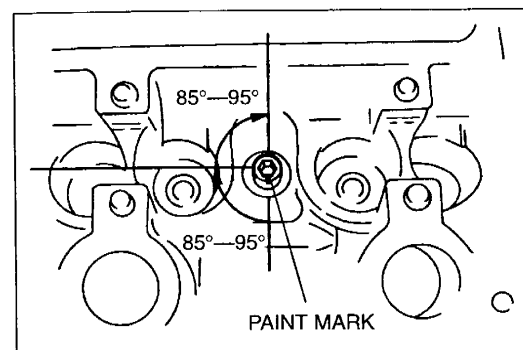

3. Put a paint mark on each bolt head.
4. Using the marks as a reference, tighten the bolts by turning each 85° — 95° in the sequence shown.
5. Further tighten each bolt by turning another 85° — 95° in the sequence shown.

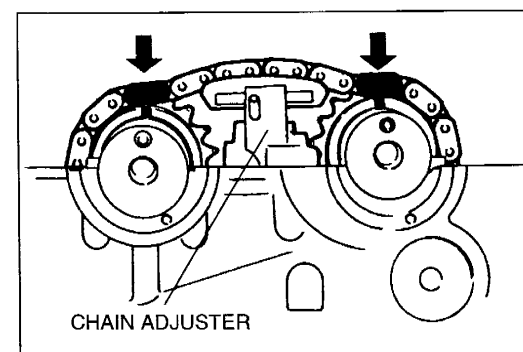

Camshaft

1. Before installation, insert the chain adjuster between camshafts.
2. Install the camshafts onto the cylinder head, aligning marks on the camshaft gear and the timing chain.

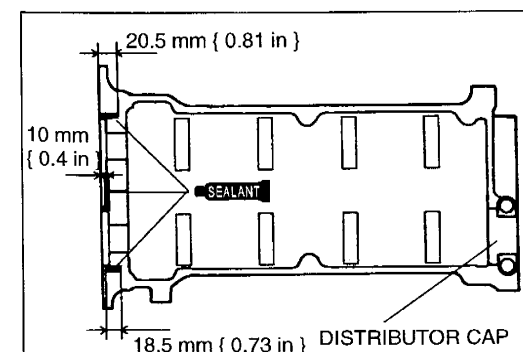

3. Apply silicone sealant to the shaded areas shown.

Thickness: $\phi 1$ mm { 0.04 in }

4. Install the camshaft caps to the positions from which they were removed.

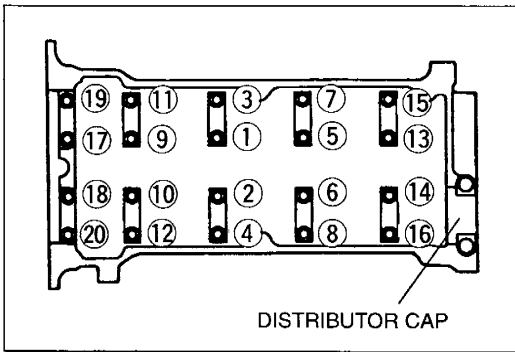

5. Hand tighten the camshaft cap bolts marked ⑤, ⑦, ②, and ④.
6. Tighten the camshaft cap bolts in five or six steps in the order shown.

Tightening torque: 11.3—14.2 N·m
{ 115—145 kgf·cm , 99.9—125 in·lbf }

7. Apply clean engine oil to the lip of the new camshaft oil seal.
8. Push the oil seal slightly in by hand.
9. Tap the oil seal in evenly by using a pipe and a hammer.

Note

- Oil seal outer diameter : 48.0 mm { 1.89 in }
- Oil seal inner diameter : 34.2 mm { 1.35 in }

Ⓐ

IN: 0—0.7 mm { 0—0.02 in }
EX: 1—1.7 mm { 0.04—0.06 in }

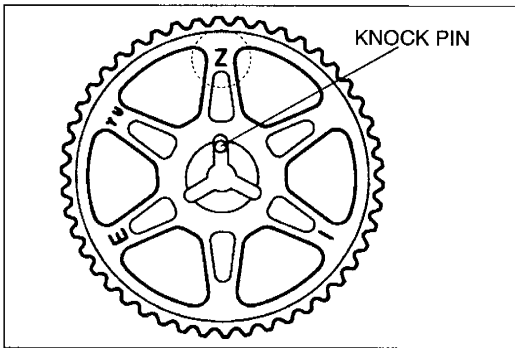
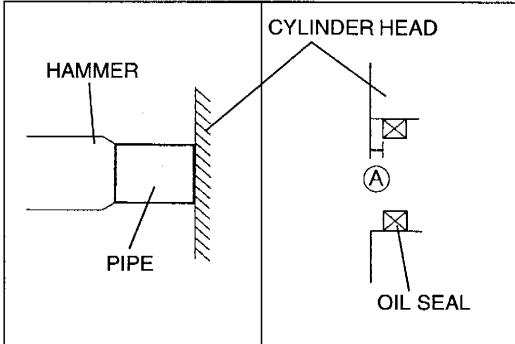

Camshaft pulley

1. Align the "Z" mark with the camshaft knock pin and install the camshaft pulley.

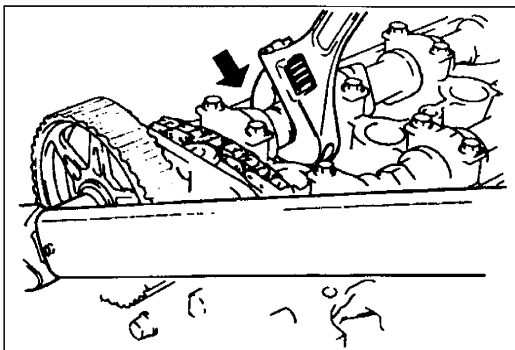

2. Hold the camshaft by using a wrench on the cast hexagon, and tighten the lock bolt.

Tightening torque:
50—60 N·m { 5.0—6.2 kgf·m , 37—44 ft·lbf }

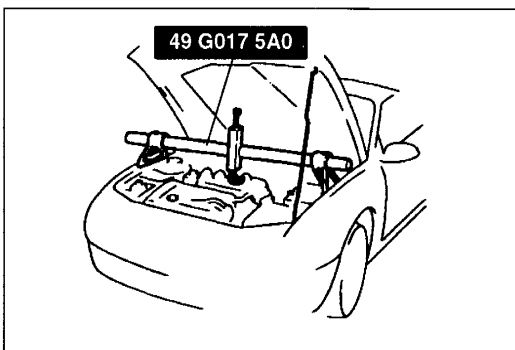

3. Support the engine by using the **SST**.
4. Remove the No.3 engine mount bracket.

FRONT OIL SEAL

PREPARATION

SST

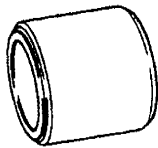
49 B014 001		For installation of front oil seal
Installer, oil seal		

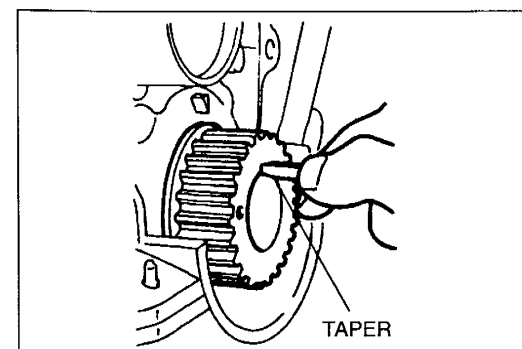
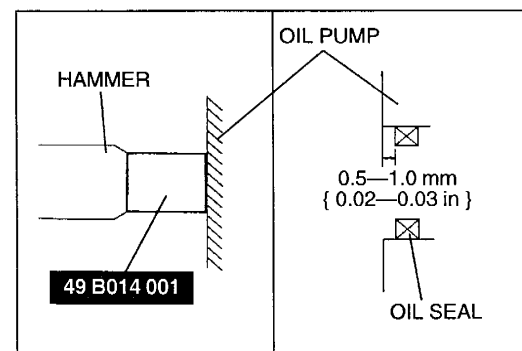
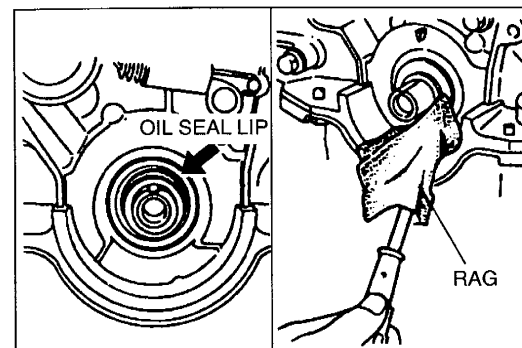
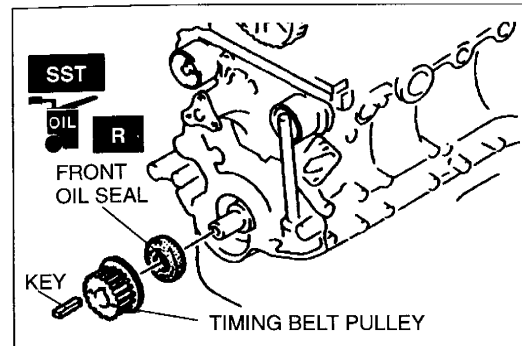



REPLACEMENT

1. Disconnect the negative battery cable.
2. Remove the timing belt. (Refer to page B1-8.)
3. Remove the timing belt pulley.
4. Remove the key.
5. Cut the oil seal lip by using a razor knife.
6. Remove the oil seal by using a screwdriver protected with a rag.
7. Apply clean engine oil to the new oil seal.
8. Push the oil seal slightly in by hand.
9. Tap the oil seal in evenly by using the **SST** and a hammer.
10. Install the timing belt pulley, aligning the key groove.
11. Insert the key with the tapered side toward the oil pump body.
12. Install the timing belt. (Refer to page B1-8.)
13. Connect the negative battery cable.
14. Start the engine and check the ignition timing. (Refer to section F1.)

REAR OIL SEAL

PREPARATION

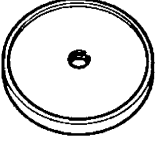
SST

<p>49 W033 105</p> <p>Installer, oil seal</p> 	<p>For installation of rear oil seal</p>	<p>49 G030 795</p> <p>Installer, oil seal</p> 	<p>For installation of rear oil seal</p>
<p>49 G030 797</p> <p>Handle (Part of 49 G030 795)</p> 	<p>For installation of rear oil seal</p>	<p>—</p>	<p>—</p>

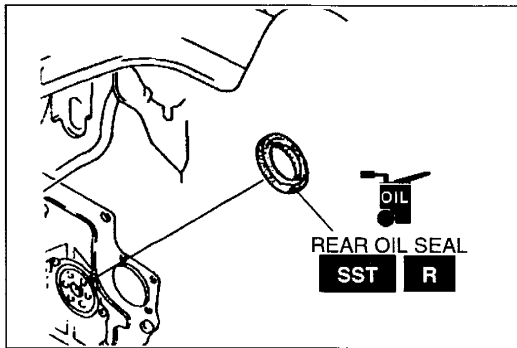

REPLACEMENT

1. Disconnect the negative battery cable.
2. Remove the transaxle assembly.
(Refer to section J, K.)
3. Remove the clutch cover and clutch disc (MTX).
(Refer to section H.)
4. Remove the flywheel (MTX) or drive plate (ATX).
(Refer to section J, K.)
5. Cut the oil seal lip by using a razor knife.
6. Remove the oil seal by using a screwdriver protected with a rag.
7. Apply clean engine oil to the new oil seal.
8. Push the oil seal slightly in by hand.
9. Tap the oil seal in evenly by using the **SST** and a hammer.
10. Install the flywheel (MTX) or drive plate (ATX).
(Refer to section J, K.)
11. Install the clutch disc and clutch cover (MTX).
(Refer to section H.)
12. Install the transaxle assembly.
(Refer to section J, K.)
13. Connect the negative battery cable.

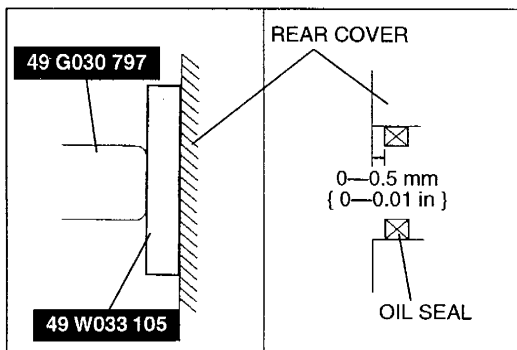
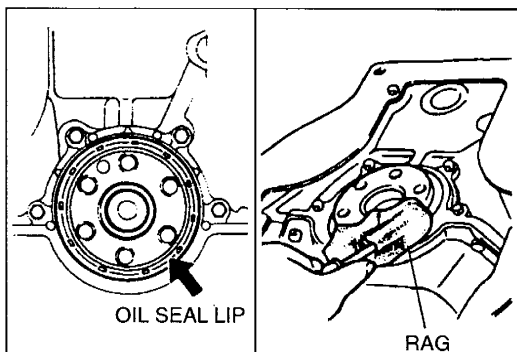

ENGINE

PREPARATION
SST

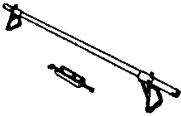
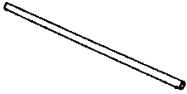
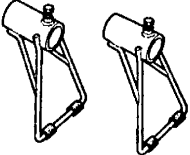
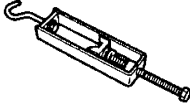
<p>49 G017 5A0</p> <p>Support, engine</p> 	<p>For support of engine</p>	<p>49 G017 501</p> <p>Bar (Part of 49 G017 5A0)</p> 	<p>For support of engine</p>
<p>49 G017 502</p> <p>Support (Part of 49 G017 5A0)</p> 	<p>For support of engine</p>	<p>49 G017 503</p> <p>Hook (Part of 49 G017 5A0)</p> 	<p>For support of engine</p>

REMOVAL / INSTALLATION
Procedure**Warning**

- Fuel line spills and leaks are dangerous. Fuel can ignite and cause serious injuries or death and damage. Fuel can also irritate skin and eyes. To prevent this, always complete the “Fuel Line Safety Procedures” on section F1.
- Fuel vapor is hazardous. It can very easily ignite, causing serious injury and damage. Always keep sparks and flames away from fuel.

Caution

- Cover the fuel hoses with a rag because fuel will spray out when disconnected.

Note

- Plug the disconnected fuel hoses to prevent fuel leakage.

1. Disconnect the negative battery cable.
2. Drain the engine coolant. (Refer to section E.)
3. Remove the hood and front wheels.
4. Drain the transaxle oil. (Refer to section J, K.)
5. Remove the radiator. (Refer to section E.)
6. Remove the three way catalytic converter and front pipe. (Refer to section F1.)
7. Remove the exhaust manifold. (Refer to section F1.)
8. Remove in the order shown in the figure, referring to **Removal Note**.
9. Install in the reverse order of removal, referring to **Installation Note**.
10. Install the exhaust manifold. (Refer to section F1.)
11. Install the front pipe and three way catalytic converter. (Refer to section F1.)
12. Install the radiator. (Refer to section E.)
13. Fill the transaxle with the specified amount and type of transaxle oil. (Refer to section J, K.)
14. Install the hood and front wheels.
15. Fill the radiator and radiator reservoir with the specified amount and type of engine coolant. (Refer to section E.)
16. Connect the negative battery cable.
17. Start the engine and
 - (1) check the engine oil, transaxle oil, and engine coolant leakage.
 - (2) check the ignition timing and idle speed. (Refer to section F1.)
18. Turn off the engine and check the drive belt deflection. (Refer to page B1–2.)
19. Perform a road test.
20. Recheck the engine oil, transaxle oil, and engine coolant levels.

Step 1

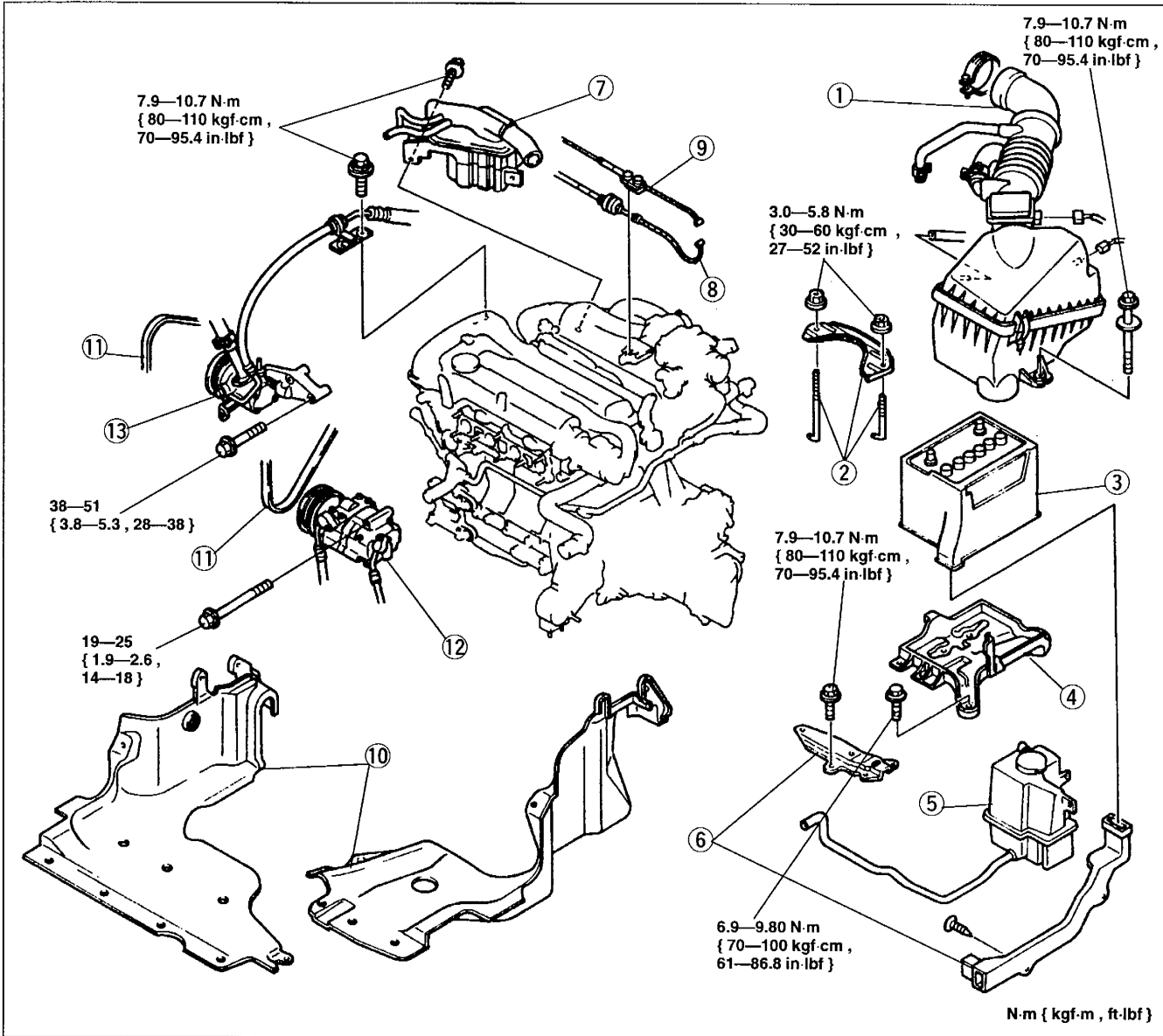

- | | |
|--|--|
| <ul style="list-style-type: none"> 1. Air cleaner 2. Battery clamp 3. Battery 4. Battery carrier 5. Radiator reservoir 6. Battery duct, bracket 7. Resonance chamber No.2 8. Accelerator cable
Adjustment section F1 | <ul style="list-style-type: none"> 9. Throttle cable (ATX)
Adjustment section K 10. Splash shield 11. Drive belt
Adjustment page B1-3 12. A/C compressor (if equipped)
Removal Note below 13. P/S oil pump
Removal Note below |
|--|--|

Removal Note

A/C compressor (if equipped)

1. Remove the A/C compressor with the hoses still connected. (Refer to section U.)
2. Position the compressor away from the engine and affix it with wire.

P/S oil pump

1. Remove the P/S oil pump with the hoses still connected. (Refer to section N.)
2. Position the pump away from the engine and affix it with wire

Step 3

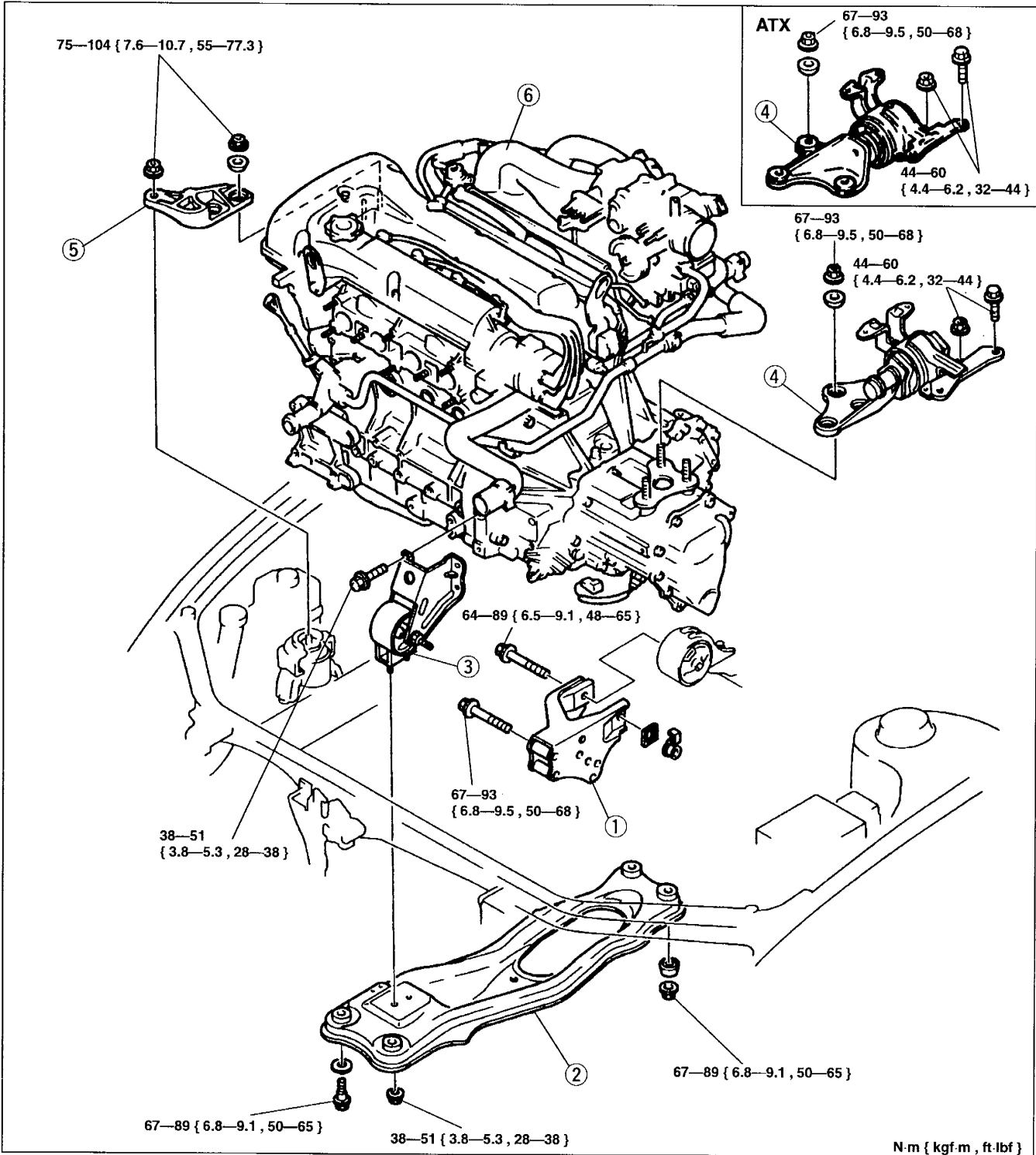

- | | |
|--|--|
| 1. No.1 engine mount bracket | 4. No.4 engine mount bracket |
| Removal Note page B1-25 | Removal Note page B1-25 |
| Installation Note page B1-27 | Installation Note page B1-26 |
| 2. Engine mount member | 5. No.3 engine mount bracket |
| Removal Note page B1-25 | Removal Note page B1-25 |
| Installation Note page B1-27 | Installation Note page B1-26 |
| 3. No.2 engine mount bracket | 6. Engine and transaxle assembly |
| Removal Note page B1-25 | Removal Note page B1-26 |
| Installation Note page B1-26 | Installation Note page B1-26 |

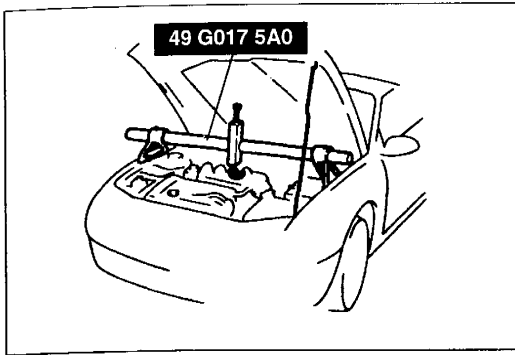

Removal Note

No.1 engine mount bracket

1. Support the engine by using the **SST**.
2. Remove the No.1 engine mount bracket.

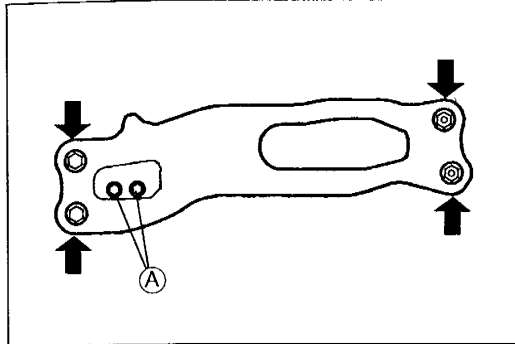

Engine mount member

1. Remove the No.2 engine mount nuts (A).
2. Remove the engine mount member bolts and nuts.
3. Remove the engine mount member.

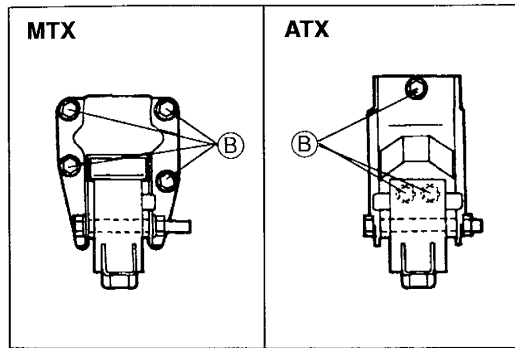

No.2 engine mount bracket

1. Remove the No.2 engine mount bracket bolts (B).
2. Remove the No.2 engine mount bracket.

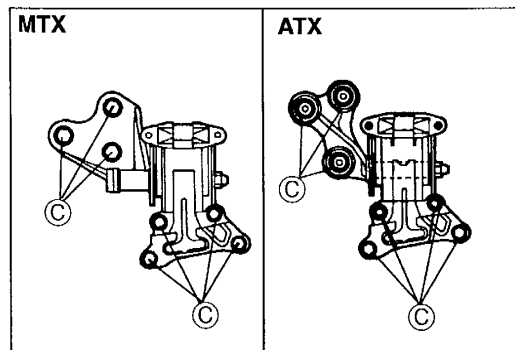

No.4 engine mount bracket

1. Remove the engine and transaxle assembly from the **SST** (Support, engine) and securely support it with the chain block.
2. Remove the No.4 engine mount bracket bolts and nuts marked (C).
3. Remove the No.4 engine mount bracket.

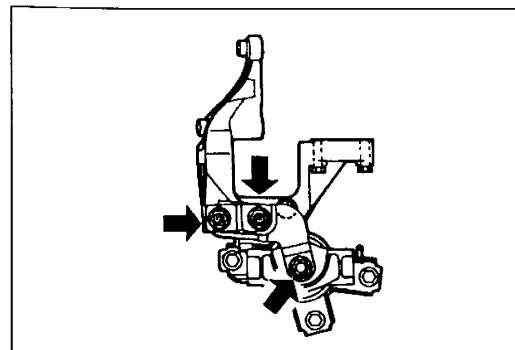

No.3 engine mount bracket

Remove the No.3 engine mount bracket nuts.

Engine and transaxle assembly

Slowly lift up the engine and transaxle assembly as a unit. Keep the engine from swinging or bumping into components in the engine compartment.

Installation Note

Engine and transaxle assembly

Slowly lower the engine and transaxle assembly as a unit. Keep the engine from swinging or bumping into components in the engine compartment.

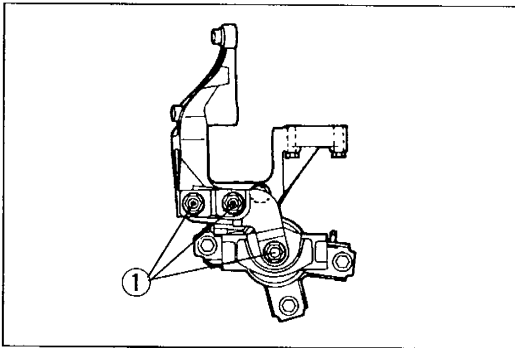

No.3 engine mount bracket

Hand tighten No.3 engine mount bracket nuts ①.

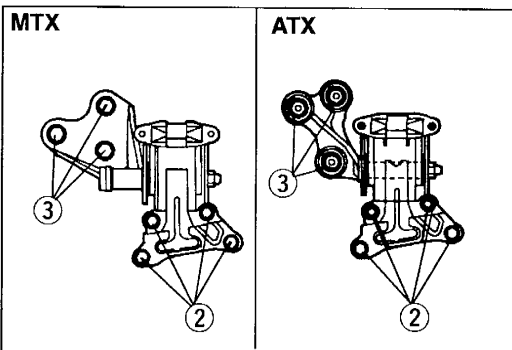

No.4 engine mount bracket

1. Hand tighten No.4 engine mount bracket bolts and nuts ②.
2. Hand tighten No.4 engine mount bracket nuts ③.

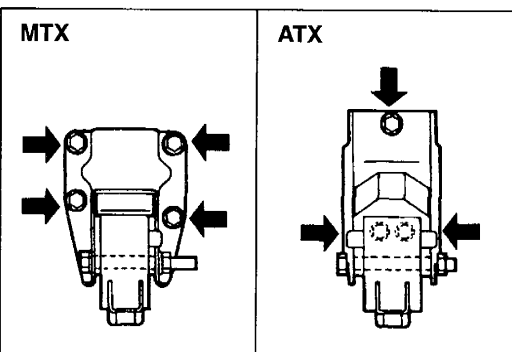

No.2 engine mount bracket

Install No.2 engine mount bracket.

Tightening torque:

38—51 N·m { 3.8—5.3 kgf·m , 28—38 ft·lbf }

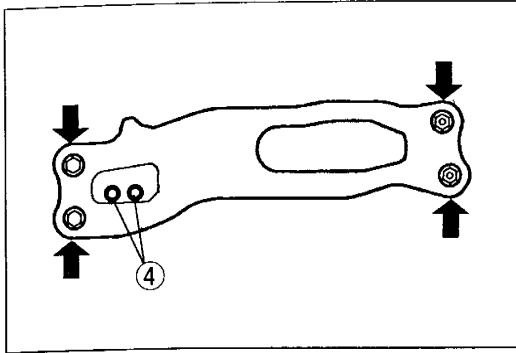
**Engine mount member**

1. Install the engine mount member.

Tightening torque:

67—89 N·m { 6.8—9.1 kgf·m , 50—65 ft·lbf }

2. Hand tighten No.2 engine mount nuts ④.

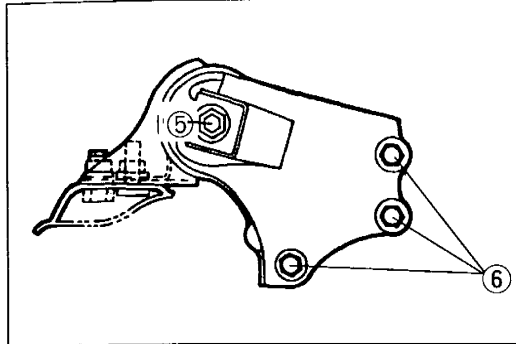
**No.1 engine mount bracket**

1. Tighten No.1 engine mount bracket bolts ⑤, ⑥.

Tightening torque

⑤: 64—89 N·m { 6.5—9.1 kgf·m , 48—65 ft·lbf }

⑥: 67—93 N·m { 6.8—9.5 kgf·m , 50—68 ft·lbf }

2. Remove the chain block.

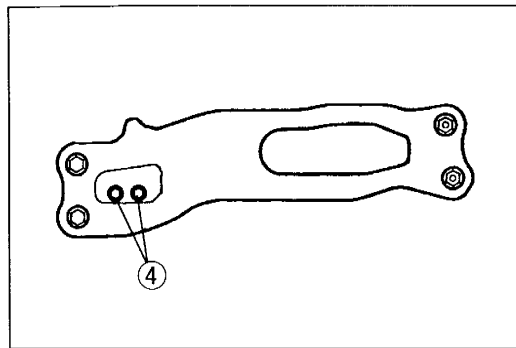

3. Tighten the engine mount bolts and nuts as follows.
 - (1) No.2 engine mount.

Tightening torque

④: 38—51 N·m { 3.8—5.3 kgf·m , 28—38 ft·lbf }

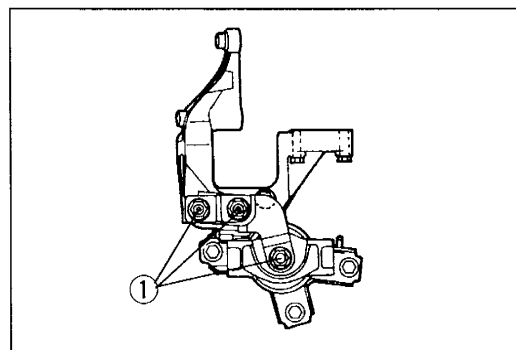

- (2) No.3 engine mount bracket.

Tightening torque

①: 75—104 N·m { 7.6—10.7 kgf·m , 55—77.3 ft·lbf }

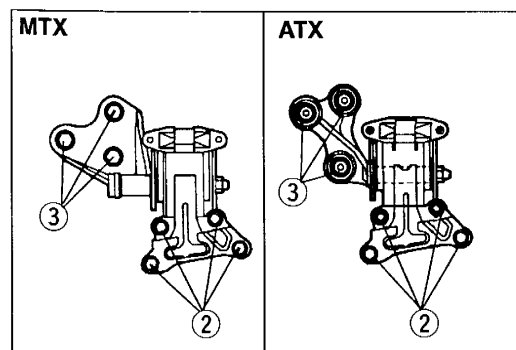

- (3) No.4 engine mount bracket.

Tightening torque

②: 44—60 N·m { 4.4—6.2 kgf·m , 32—44 ft·lbf }

③: 67—93 N·m { 6.8—9.5 kgf·m , 50—68 ft·lbf }

DISASSEMBLY / ASSEMBLY

1. Disconnect the engine and transaxle. (Refer to section J, K.)
2. Remove the clutch cover and clutch disc (MTX). (Refer to section H.)
3. Remove the intake-air system and crankshaft position sensor. (Refer to section F1.)
4. Disassemble in the order shown in the figure.
5. Assemble in the reverse order of disassembly.
6. Install the intake-air system and crankshaft position sensor. (Refer to section F1.)
7. Install the clutch disc and clutch cover (MTX). (Refer to section H.)
8. Connect the engine and transaxle. (Refer to section J, K.)

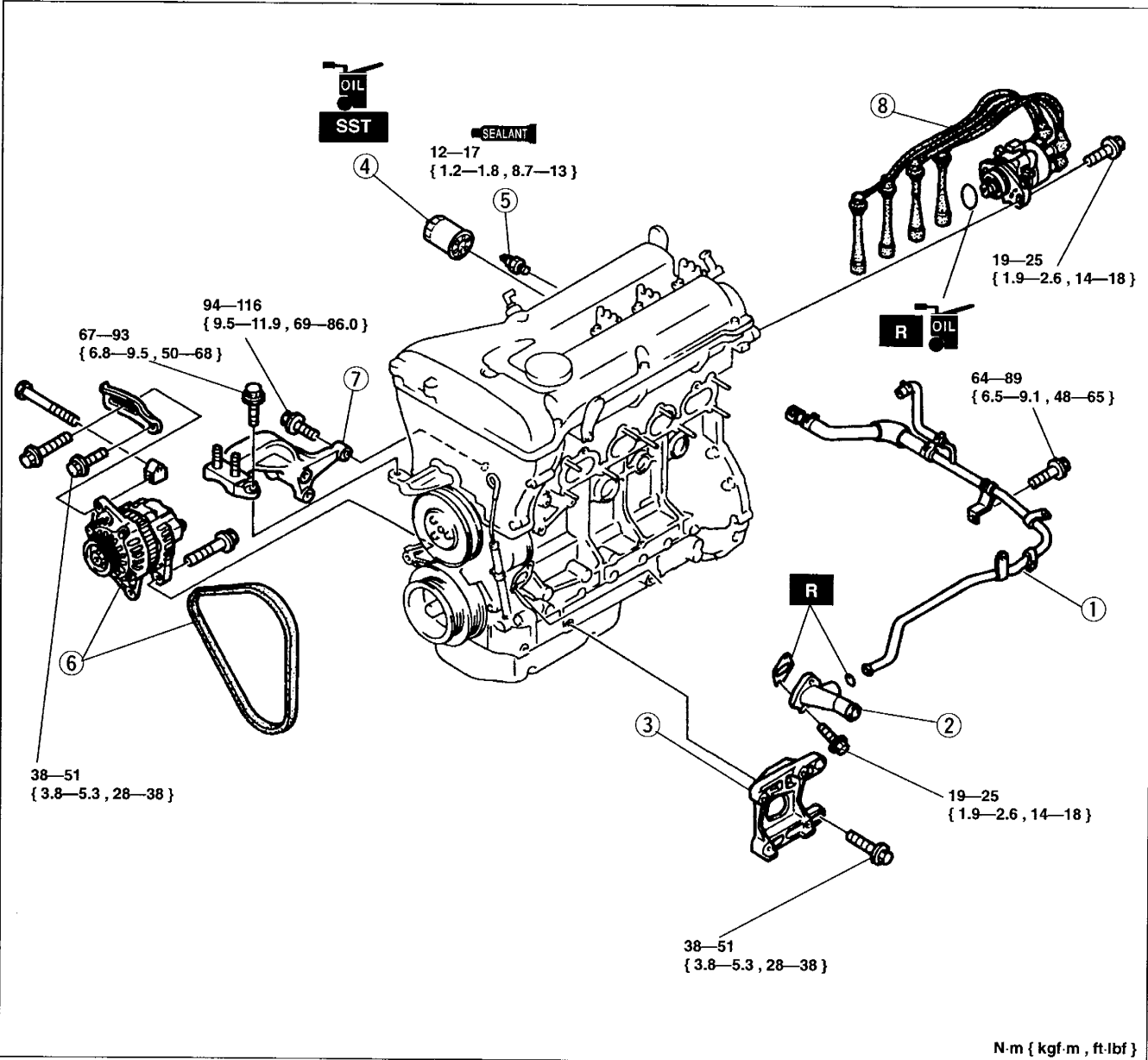

- | | |
|---|--|
| <ol style="list-style-type: none"> 1. Water bypass pipe 2. Water inlet pipe 3. A/C compressor bracket (if equipped) 4. Oil filter
Removal / Installation section D 5. Oil pressure switch
Removal / Installation section D | <ol style="list-style-type: none"> 6. Generator and drive belt
Adjustment page B1-3 7. No.3 engine mount 8. Distributor |
|---|--|

Before beginning any service procedure, refer to section T1 of this manual for air bag system service warnings.

ENGINE

(BP)

DRIVE BELT	B2- 2
PREPARATION	B2- 2
INSPECTION / ADJUSTMENT	B2- 2
COMPRESSION	B2- 4
INSPECTION	B2- 4
TIMING BELT	B2- 5
PREPARATION	B2- 5
REMOVAL / INSTALLATION	B2- 5
CYLINDER HEAD GASKET	B2-11
PREPARATION	B2-11
REPLACEMENT	B2-11
HLA	B2-14
PREPARATION	B2-14
REMOVAL / INSPECTION / INSTALLATION ...	B2-14
FRONT OIL SEAL	B2-18
PREPARATION	B2-18
REPLACEMENT	B2-18
REAR OIL SEAL	B2-19
PREPARATION	B2-19
REPLACEMENT	B2-19
ENGINE	B2-20
PREPARATION	B2-20
REMOVAL / INSTALLATION	B2-20
DISASSEMBLY / ASSEMBLY	B2-27

DRIVE BELT

PREPARATION SST

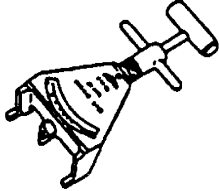
<p>49 9200 020A</p> <p>Tension gauge, belt</p> 	<p>For inspection of drive belt tension</p>
--	---

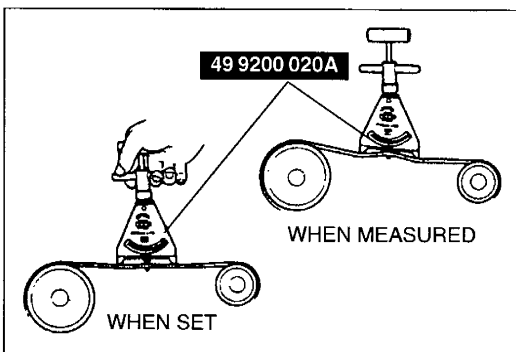
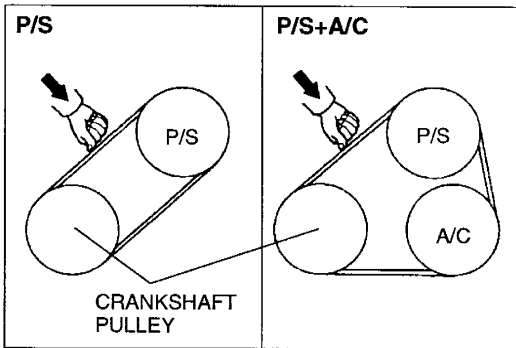
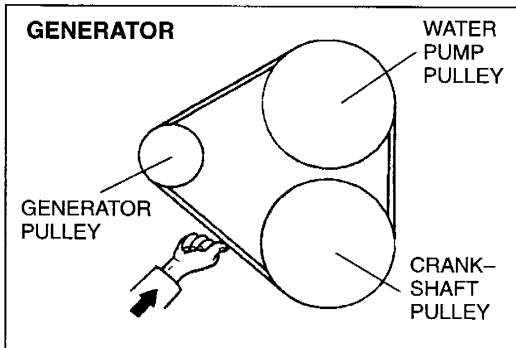

INSPECTION / ADJUSTMENT

Inspection

1. Check the drive belt deflection when the engine is cold, or at least 30 minutes after the engine has stopped. Apply moderate pressure **98 N { 10 kgf , 22 lbf }** midway between the specified pulleys.

Deflection

Drive belt	mm { in }		
	*New	Used	Limit
Generator	5.5—7.0 { 0.22—0.27 }	6.0—7.5 { 0.24—0.29 }	8.0 { 0.31 }
P/S, P/S+A/C	8.0—9.0 { 0.32—0.35 }	9.0—10.0 { 0.36—0.39 }	11.5 { 0.45 }

*A belt that has been on a running engine for less than five minutes.

2. If the deflection is not within the specification, adjust it. (Refer to page B2-3.)

Drive belt tension check

1. Belt tension can be checked in place of belt deflection. Check the drive belt tension when the engine is cold, or at least 30 minutes after the engine has stopped. Using the **SST**, check the belt tension between any two pulleys.

Tension

Drive belt	N { kgf , lbf }		
	*New	Used	Limit
Generator	500—740 { 50—76 , 110—160 }	500—700 { 50—72 , 110—150 }	340 { 35 , 77 }
P/S, P/S+ A/C	500—580 { 50—60 , 110—130 }	430—490 { 43—50 , 95—110 }	250 { 25 , 55 }

*A belt that has been on a running engine for less than five minutes.

2. If the tension is not within the specification, adjust it. (Refer to page B2-3.)

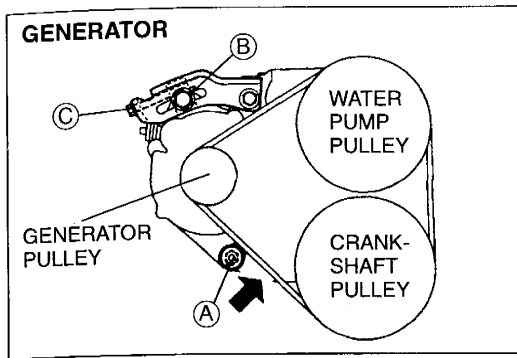

Adjustment
Generator drive belt

1. Loosen bolts (A) and (B).
2. Adjust the belt deflection by turning adjusting bolt (C).

B2

Deflection (At 98 N { 10 kgf , 22 lbf })
New : 5.5—7.0 mm { 0.22—0.27 in }
Used: 6.0—7.5 mm { 0.24—0.29 in }

3. Tighten bolts (A) and (B).

Tightening torque

- (A): 38—51 N·m { 3.8—5.3 kgf·m , 28—38 ft·lbf }
- (B): 19—25 N·m { 1.9—2.6 kgf·m , 14—18 ft·lbf }

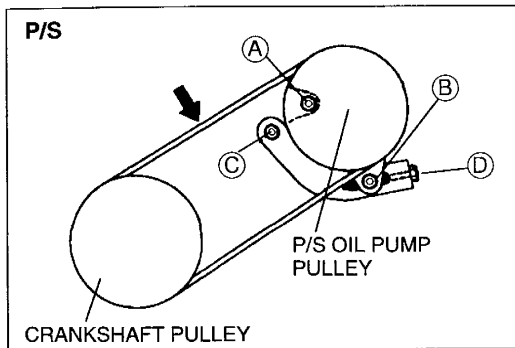

P/S, P/S + A/C drive belt

1. Loosen the bolts and nuts marked (A), (B) and (C).
2. Adjust the belt deflection by turning adjusting bolt (D).

Deflection (At 98 N { 10 kgf , 22 lbf })
New: 8.0—9.0 mm { 0.32—0.35 in }
Used: 9.0—10.0 mm { 0.36—0.39 in }

3. Tighten the bolts and nuts marked (A), (B) and (C).

Tightening torque

- (A): 44—60 N·m { 4.4—6.2 kgf·m , 32—44 ft·lbf }
- (B): 38—51 N·m { 3.8—5.3 kgf·m , 28—38 ft·lbf }
- (C): 38—51 N·m { 3.8—5.3 kgf·m , 28—38 ft·lbf }

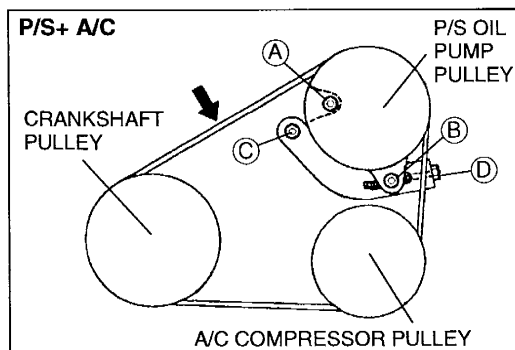

COMPRESSION

INSPECTION

1. Verify that the battery is fully charged. Recharge it if necessary. (Refer to section G.)
2. Warm up the engine to the normal operating temperature.
3. Stop the engine and allow it to cool for about 10 minutes.
4. Remove the spark plugs.
5. Disconnect the distributor connectors.
6. Connect a compression gauge into the No.1 spark plug hole.
7. Measure compression in the following procedure.
 - (1) Fully depress the accelerator pedal or fully open the throttle valve.
 - (2) Crank the engine and note the maximum gauge reading.

Compression

kPa { kgf/cm² , psi }-rpm

Standard	1275 { 13.0 , 185 }-300
Minimum	961 { 9.8 , 139 }-300
Maximum difference between cylinders	196 kPa { 2.0 kgf/cm ² , 28 psi }





- (3) Check each cylinder as above.
- (4) If the compression in one or more cylinders is low, pour a small amount of clean engine oil into the cylinder and recheck the compression.
 - ① If the compression increases, the piston, piston rings, or cylinder wall may be worn.
 - ② If the compression stays low, a valve may be stuck or improperly seated.
 - ③ If the compression in adjacent cylinders stays low, the cylinder head gasket may be damaged or the cylinder head distorted.
8. Disconnect the compression gauge.
9. Connect the distributor connectors.
10. Install the spark plugs.

Tightening torque: 15—22 N·m { 1.5—2.3 kgf·m , 11—16 ft·lbf }

TIMING BELT

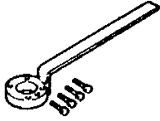
PREPARATION
SST

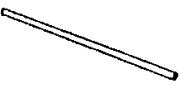
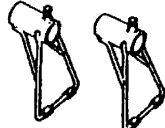
B2

<p>49 D011 102</p> <p>Lock tool, crankshaft</p> 	<p>For prevention of crankshaft rotation</p>	<p>49 G017 5A0</p> <p>Support, engine</p> 	<p>For support of engine</p>
<p>49 G017 501</p> <p>Bar (Part of 49 G017 5A0)</p> 	<p>For support of engine</p>	<p>49 G017 502</p> <p>Support (Part of 49 G017 5A0)</p> 	<p>For support of engine</p>
<p>49 G017 503</p> <p>Hook (Part of 49 G017 5A0)</p> 	<p>For support of engine</p>	<p>—</p>	<p>—</p>

REMOVAL / INSTALLATION

Caution

- The crankshaft position sensor rotor is on the rear of the crankshaft pulley, and can be damaged easily.

1. Disconnect the negative battery cable.
2. Remove the right front wheel.
3. Remove in the order shown in the figure, referring to **Removal Note**.
4. Install in the reverse order of removal, referring to **Installation Note**.
5. Install the right front wheel.
6. Connect the negative battery cable.
7. Start the engine and
 - (1) check the pulleys and the timing belt for runout and contact.
 - (2) check the ignition timing. (Refer to section F2.)

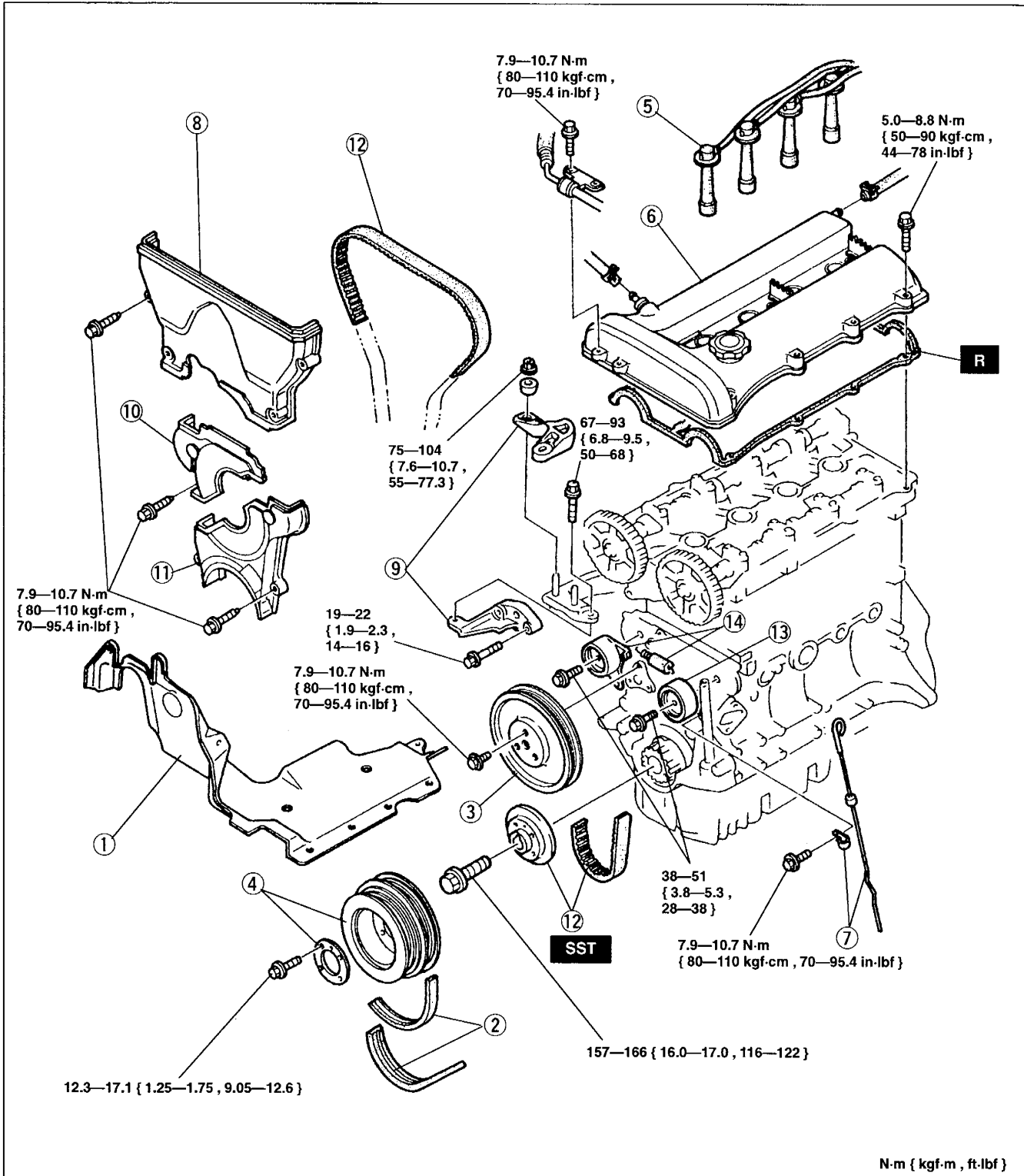

- | | |
|--|------------|
| 1. Splash shield (RH) | |
| 2. Drive belt | |
| Adjustment | page B2- 3 |
| 3. Water pump pulley | |
| 4. Crankshaft pulley | |
| 5. High-tension lead | |
| 6. Cylinder head cover | |
| Installation Note | page B2-10 |
| 7. Dipstick and pipe stay | |
| 8. Timing belt cover, upper | |
| 9. No.3 engine mount bracket | |
| Removal Note | below |
| Installation Note | page B2-10 |
| 10. Timing belt cover, middle | |
| 11. Timing belt cover, lower | |
| 12. Pulley boss, timing belt | |
| Removal Note | below |
| Installation Note | page B2- 8 |
| 13. Idler pulley | |
| 14. Tensioner pulley, tensioner spring | |
| Installation Note | page B2- 8 |

B2

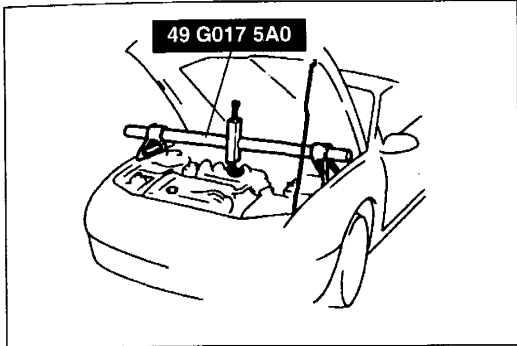

Removal Note

No.3 engine mount bracket

1. Support the engine by using the **SST**.
2. Remove the No.3 engine mount bracket.

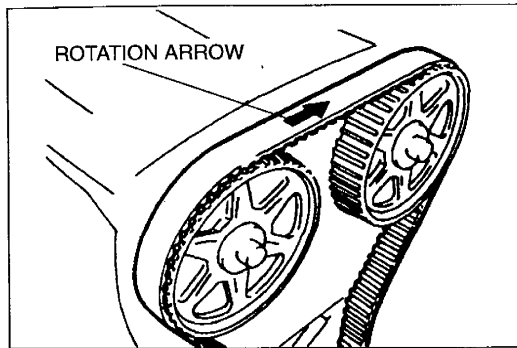

Pulley boss, timing belt

Note

- Mark the timing belt rotation on the belt for proper reinstallation.

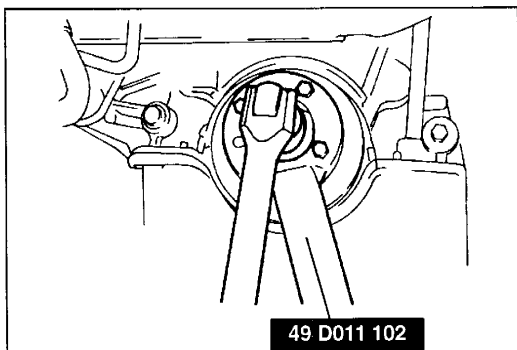

1. By using the **SST**, remove the pulley lock bolt.
2. Remove the pulley boss.

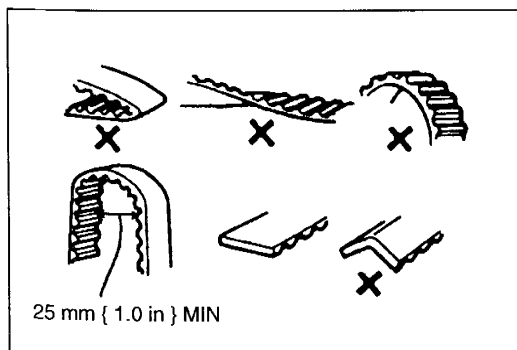

Caution

- The following will damage the belt and shorten its life; Forcefully twisting it, turning it inside out, or allowing oil or grease on it.

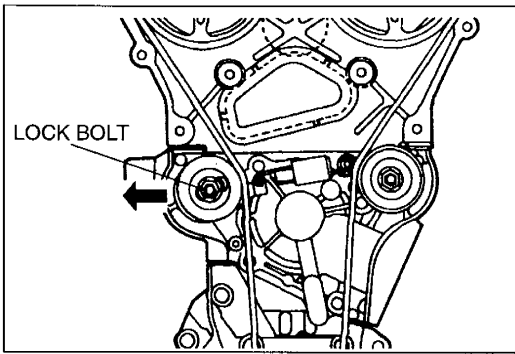

LOCK BOLT

3. Loosen the tensioner pulley lock bolt.
4. Pull the tensioner pulley in the direction of the arrow to reduce tension of the timing belt, and remove the belt.

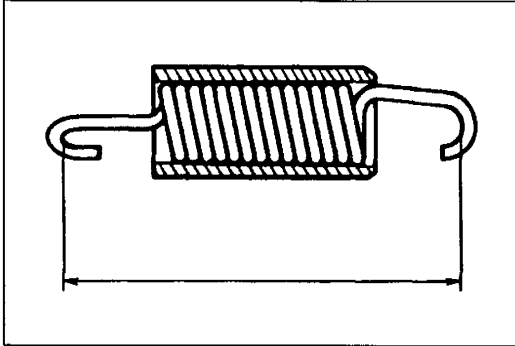

Installation Note

Tensioner pulley, tensioner spring

1. Measure the tensioner spring free length. If not within the specification, replace the tensioner spring.

Free length: 59.2 mm { 2.33 in }

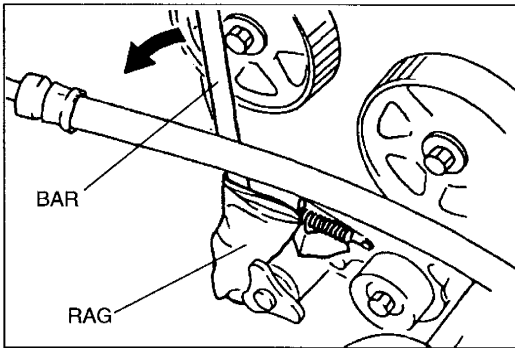

BAR

RAG

2. Install the tensioner and the tensioner spring.
3. Temporarily secure the tensioner with the spring fully extended.

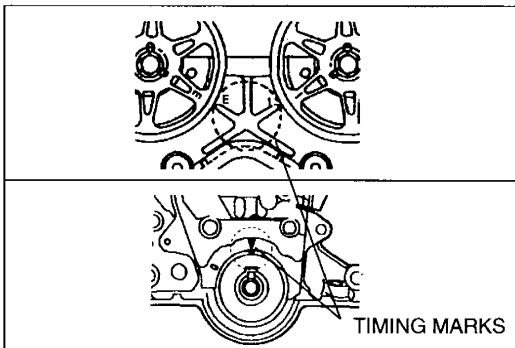

TIMING MARKS

Pulley boss, timing belt

1. Verify that all timing marks are correctly aligned.

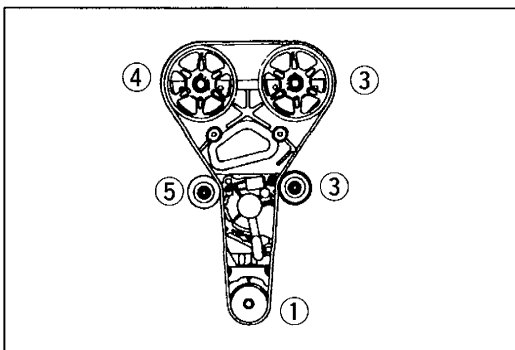

2. Install the timing belt on the pulleys in the order shown below.

- ① Timing belt pulley
- ② Idler pulley
- ③ Camshaft pulley (LH)
- ④ Camshaft pulley (RH)
- ⑤ Tensioner pulley

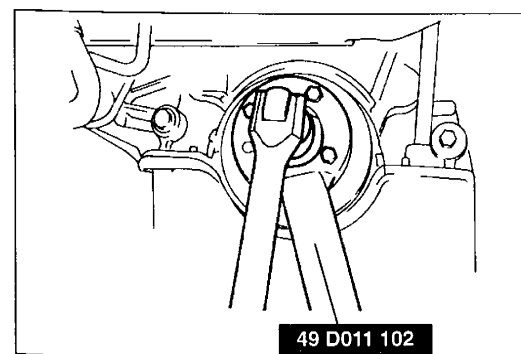
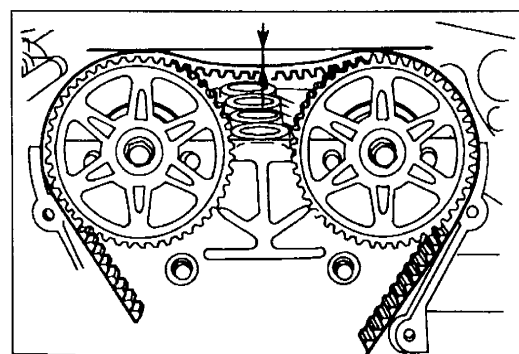
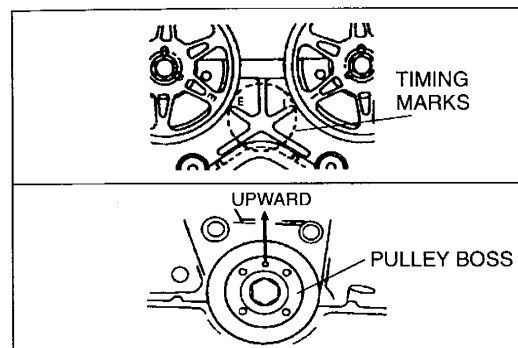
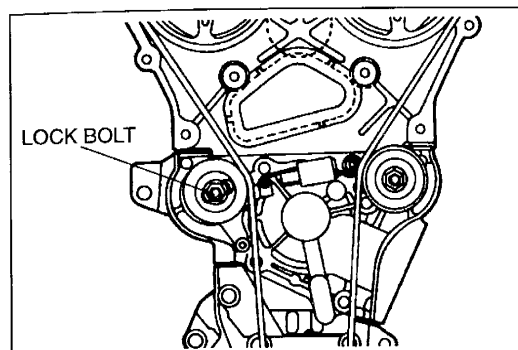
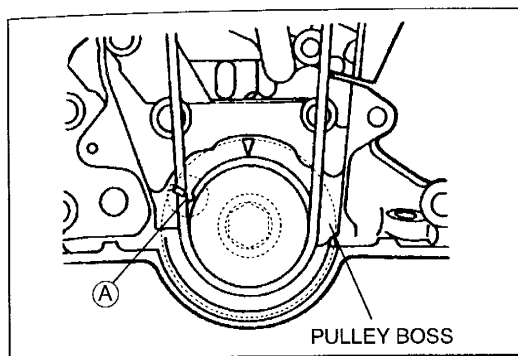

3. Install the pulley boss and pulley lock bolt. Turn the crankshaft clockwise 1 and 5/6 times, and verify that the timing mark on the timing belt pulley is aligned with timing mark **A** (tensioner set mark).

B2

4. Loosen the tensioner lock bolt to apply tension to the timing belt. Do not apply tension other than that of the tensioner spring.
5. Tighten the tensioner pulley lock bolt.

Tightening torque:

38—51 N·m { 3.8—5.3 kgf·m , 28—38 ft·lbf }

6. Turn the crankshaft 2 and 1/6 times clockwise, and verify that all timing marks are correctly aligned.

Note

- The pin on the pulley boss must face upward.

7. Check the belt deflection at the point indicated by applying moderate pressure **98 N { 10 kgf , 22 lbf }**.

Deflection: 9.0—11.5 mm { 0.36—0.45 in }

8. If the timing belt deflection is not correct, remove the timing belt and repeat from step 1.

9. Mount the **SST** on the pulley boss to hold the crankshaft. Tighten the lock bolt.

Tightening torque:

157—166 N·m { 16.0—17.0 kgf·m , 116—122 ft·lbf }

10. Remove the **SST**.

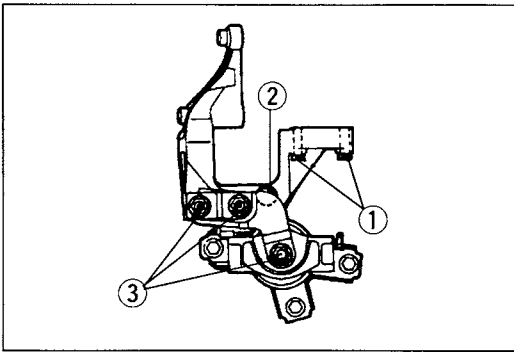

No.3 engine mount bracket

1. Install the No.3 engine mount bracket.

Tightening torque

- ①: 19—22 N·m { 1.9—2.3 kgf·m , 14—16 ft·lbf }
- ②: 67—93 N·m { 6.8—9.5 kgf·m , 50—68 ft·lbf }
- ③: 75—104 N·m { 7.6—10.7 kgf·m , 55—77.3 ft·lbf }

2. Remove the SST (Support, engine).

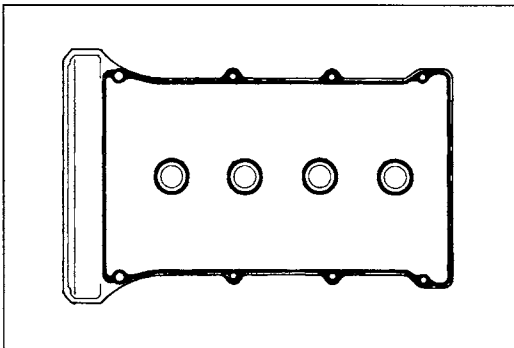

Cylinder head cover

1. Verify that the grooves on the cylinder head cover are free of oil, water and other foreign material.
2. Install the new cylinder head cover gasket into the cylinder head cover.

Caution

- Silicone sealant hardens and causes oil leakage when it is left for an extended period. Therefore, install parts before sealant hardens.

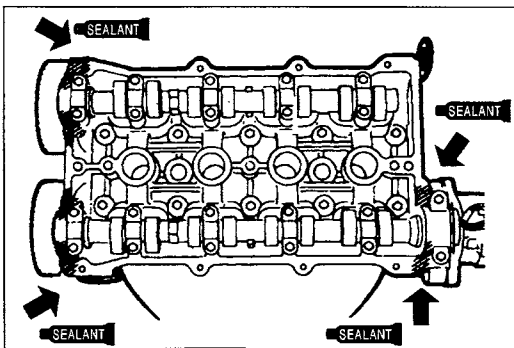

3. Apply silicone sealant to the shaded areas as shown.

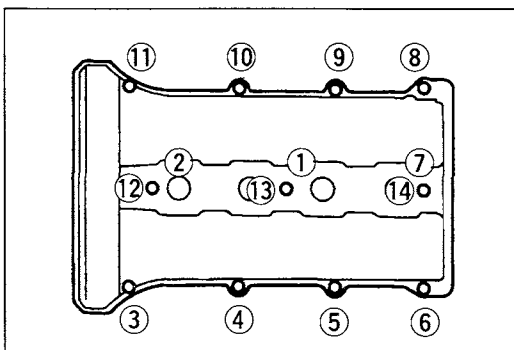



4. Install the cylinder head cover and tighten the bolts in five or six steps in the order shown.

Tightening torque:

- 5.0—8.8 N·m { 50—90 kgf·cm , 44—78 in·lbf }

CYLINDER HEAD GASKET

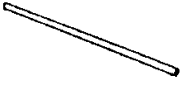
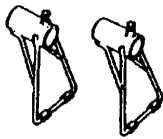
PREPARATION
SST

<p>49 G017 5A0</p> <p>Support, engine</p> 	<p>For support of engine</p>	<p>49 G017 501</p> <p>Bar (Part of 49 G017 5A0)</p> 	<p>For support of engine</p>
<p>49 G017 502</p> <p>Support (Part of 49 G017 5A0)</p> 	<p>For support of engine</p>	<p>49 G017 503</p> <p>Hook (Part of 49 G017 5A0)</p> 	<p>For support of engine</p>

REPLACEMENT

Warning

- Fuel vapor is hazardous. It can very easily ignite, causing serious injury and damage. Always keep sparks and flames away from fuel.
- Fuel line spills and leaks are dangerous. Fuel can ignite and cause serious injuries or death and damage. Fuel can also irritate skin and eyes. To prevent this, always complete the "Fuel Line Safety Procedures" on section F2.

1. Disconnect the negative battery cable.
2. Drain the engine coolant. (Refer to section E.)
3. Remove the timing belt. (Refer to page B2-5.)
4. Remove the air cleaner and front pipe. (Refer to section F2.)
5. Remove the exhaust manifold. (Refer to section F2.)
6. Remove in the order shown in the figure, referring to **Removal Note**.
7. Install in the reverse order of removal, referring to **Installation Note**.
8. Install the exhaust manifold. (Refer to section F2.)
9. Install the front pipe and air cleaner. (Refer to section F2.)
10. Install the timing belt. (Refer to page B2-5.)
11. Fill the radiator and radiator reservoir with the specified amount and type of engine coolant. (Refer to section E.)
12. Connect the negative battery cable.
13. Start the engine and
 - (1) check the engine oil and engine coolant leakage.
 - (2) check the ignition timing and idle speed. (Refer to section F2.)
14. Check the compression. (Refer to page B2-4.)

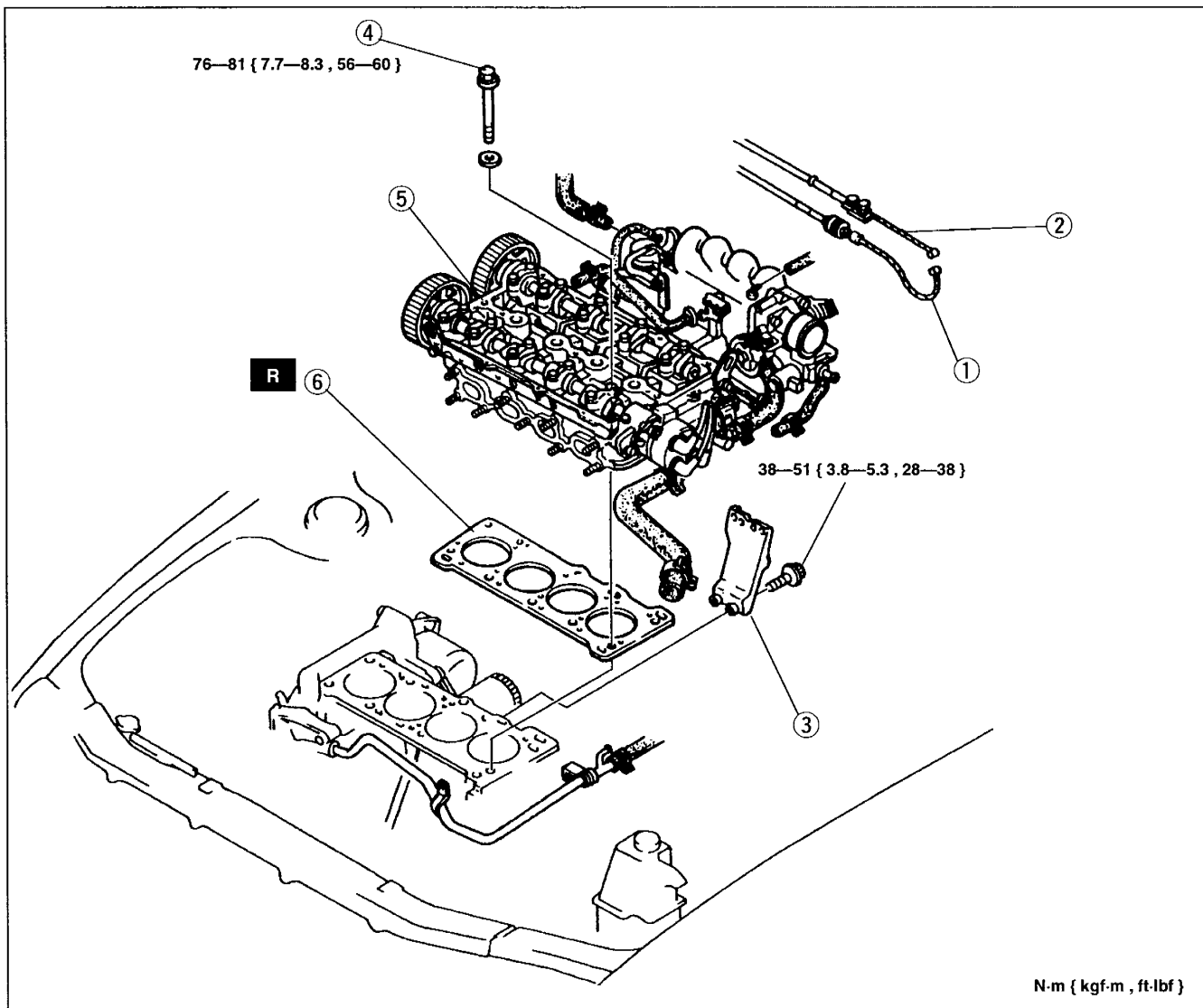

N·m { kgf·m , ft·lbf }

- | | |
|---|--|
| 1. Accelerator cable
Adjustment section F2 | 4. Cylinder head bolt
Removal Note page B2-13
Installation Note page B2-13 |
| 2. Throttle cable (ATX)
Adjustment section K | 5. Cylinder head assembly |
| 3. Intake manifold stay | 6. Cylinder head gasket |

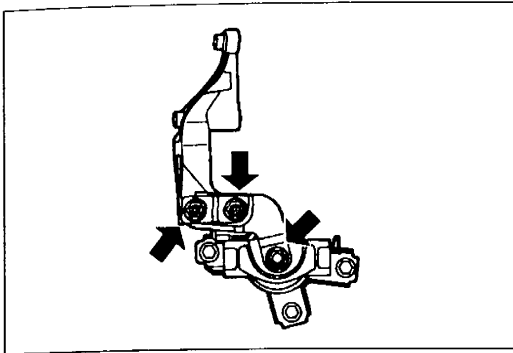

Removal Note

Cylinder head bolt

1. Temporarily install the No.3 engine mount bracket to support the engine.
2. Remove the **SST** (Support, engine).

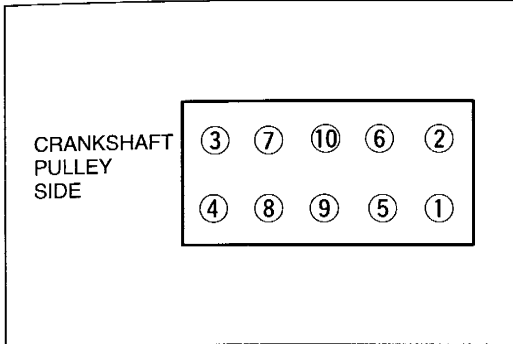

3. Loosen the cylinder head bolts in two or three steps in the order shown.
4. Remove the cylinder head bolts.

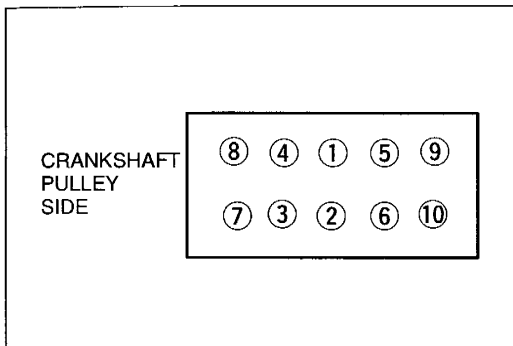

Installation Note

Cylinder head bolt

1. Tighten the cylinder head bolts in two or three steps in the order shown.

Tightening torque:

76—81 N·m { 7.7—8.3 kgf·m , 56—60 ft·lbf }

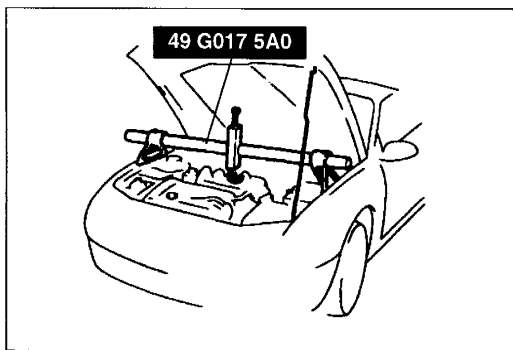

2. Support the engine by using the **SST**.
3. Remove the No.3 engine mount bracket.

HLA

PREPARATION SST

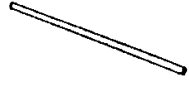
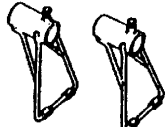
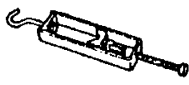
<p>49 G017 5A0</p> <p>Support, engine</p> 	<p>For support of engine</p>	<p>49 G017 501</p> <p>Bar (Part of 49 G017 5A0)</p> 	<p>For support of engine</p>
<p>49 G017 502</p> <p>Support (Part of 49 G017 5A0)</p> 	<p>For support of engine</p>	<p>49 G017 503</p> <p>Hook (Part of 49 G017 5A0)</p> 	<p>For support of engine</p>

REMOVAL / INSPECTION / INSTALLATION

Caution

- Removal and installation of the HLA must be carried out only when the problem cannot be solved by the HLA troubleshooting. (Refer to page B2-17.)

1. Disconnect the negative battery cable.
2. Remove the timing belt. (Refer to page B2-5.)
3. Remove the distributor. (Refer to section G.)
4. Remove in the order shown in the figure, referring to **Removal Note**.
5. Install in the reverse order of removal, referring to **Installation Note**.
6. Install the distributor. (Refer to section G.)
7. Install the timing belt. (Refer to page B2-5.)
8. Connect the negative battery cable.
9. Start the engine and
 - (1) check the engine oil leakage.
 - (2) check the ignition timing and idle speed. (Refer to section F2.)

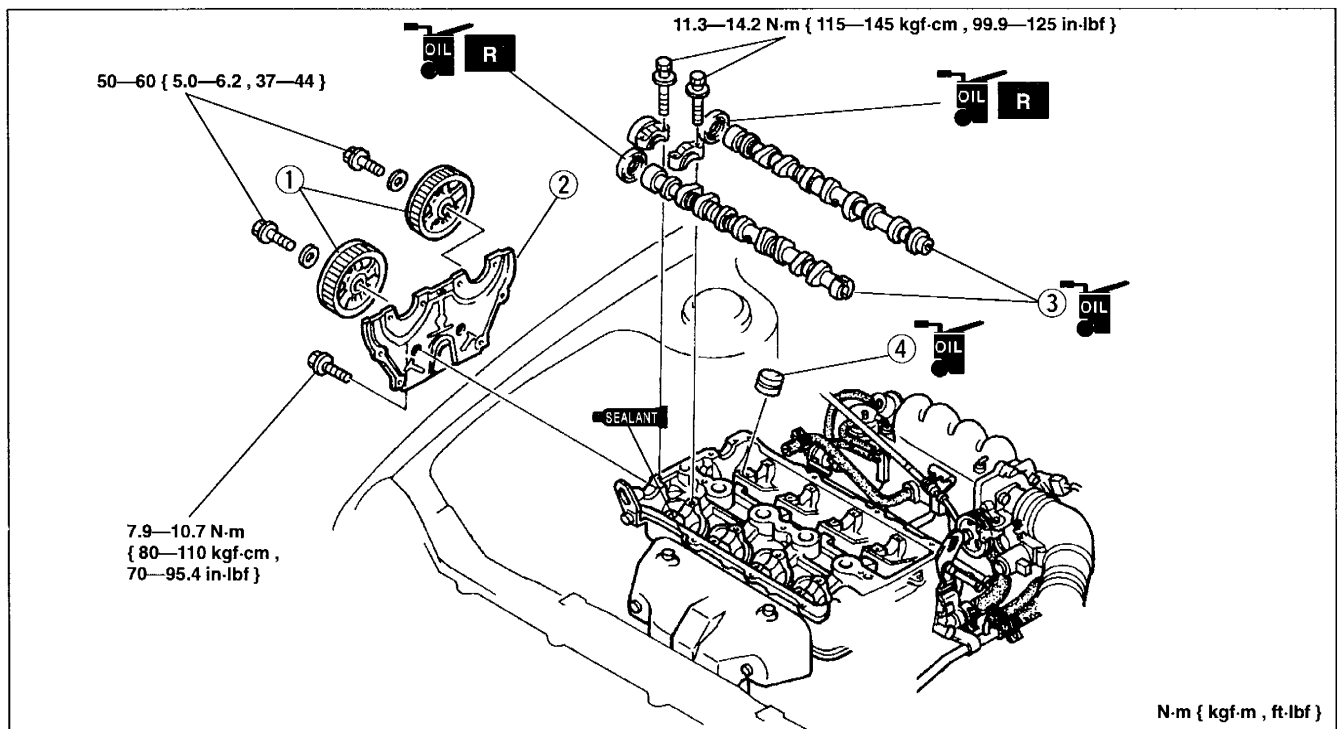

- | | |
|--|---|
| 1. Camshaft pulley
Removal Note below
Installation Note page B2-16 | 3. Camshaft
Removal Note below
Installation Note page B2-16 |
| 2. Seal plate | 4. HLA |

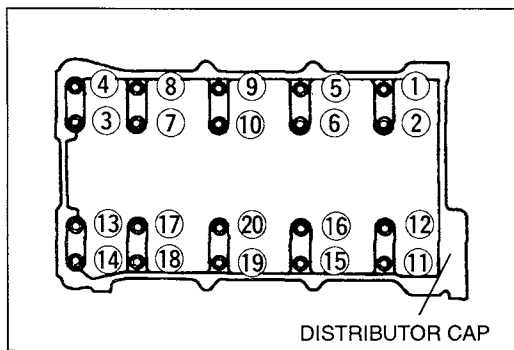
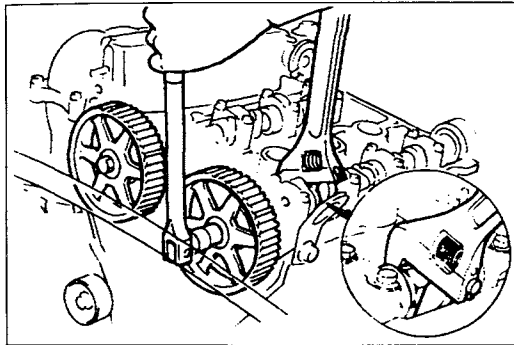
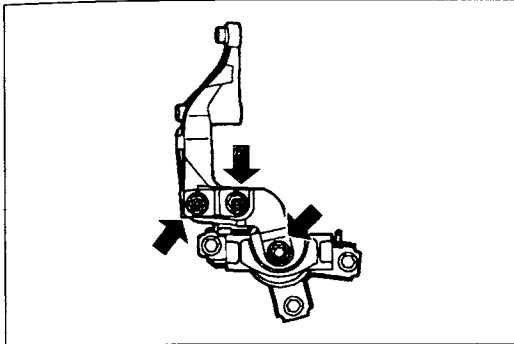

Removal Note

Camshaft pulley

1. Temporarily install the No.3 engine mount bracket to support the engine.
2. Remove the **SST** (Support, engine).

3. Hold the camshaft by using a wrench on the cast hexagon as shown, and loosen the camshaft pulley lock bolt.
4. Remove the camshaft pulley.

Camshaft

1. Rotate the camshaft clockwise so that cams do not pressing on the HLAs.
2. Loosen the camshaft cap bolts in five or six steps in the order shown.
3. Remove the camshafts.
4. Remove the camshaft oil seals.

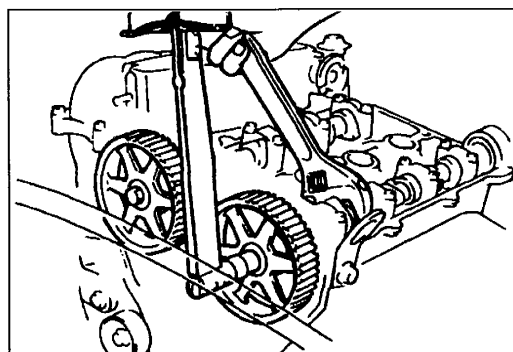
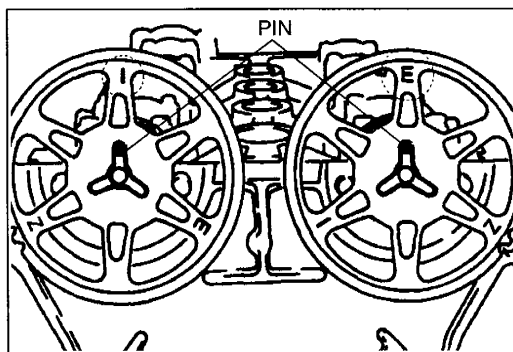
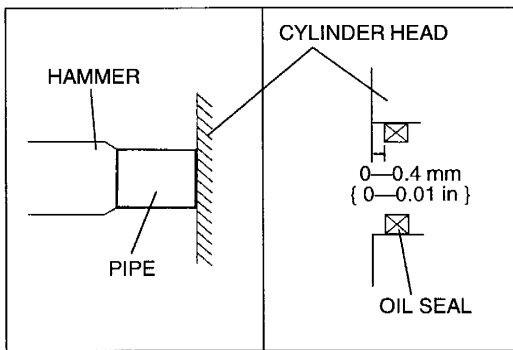
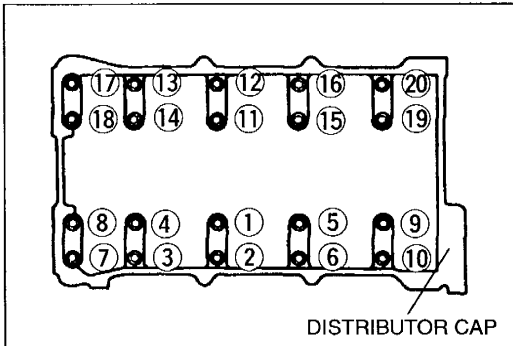
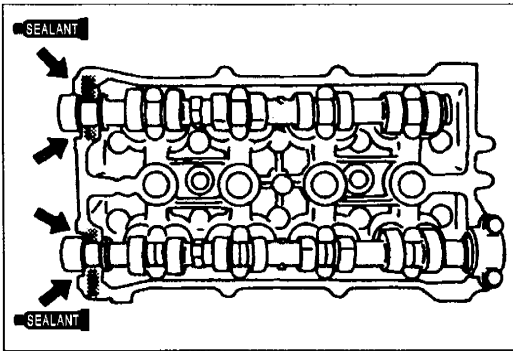

Installation Note

Camshaft

1. Install the camshafts.
2. Apply silicone sealant to the shaded areas shown.

3. Install the camshaft caps.
4. Tighten the camshaft cap bolts in five or six steps in the order shown.

Tightening torque: 11.3—14.2 N·m
 { 115—145 kgf·cm , 99.9—125 in·lbf }

5. Apply clean engine oil to the lip of the new camshaft oil seal.
6. Push the oil seal slightly in by hand.
7. Tap the oil seal in evenly by using a pipe and a hammer.

Note

- Oil seal outer diameter: 48.0 mm { 1.89 in }
- Oil seal inner diameter: 34.2 mm { 1.35 in }

Camshaft pulley

1. Face the pin on each camshaft straight up.
2. Install the camshaft pulleys so that "I" mark (intake side) and "E" mark (exhaust side) face straight up.

3. Hold the camshaft by using a wrench on the cast hexagon, and tighten the lock bolt.

Tightening torque:
 50—60 N·m { 5.0—6.2 kgf·m , 37—44 ft·lbf }

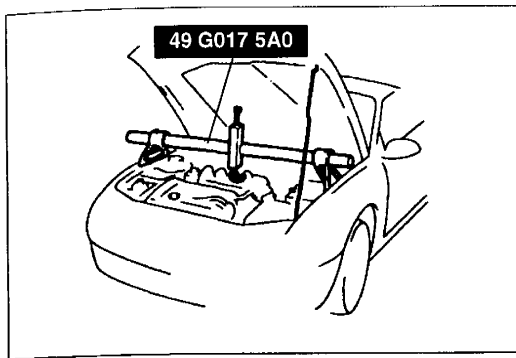

4. Support the engine by using the SST.
5. Remove the No.3 engine mount.

Troubleshooting Guide

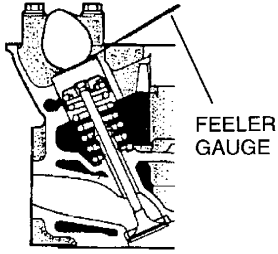
Problem	Possible cause	Action
1. Noise when engine is started immediately after oil is changed.	Oil leakage in oil passage or in HLA	Run engine at 2,000—3,000 rpm. If noise stops within 20 minutes*, HLA is normal. If not, replace HLA. * Time required for engine oil to circulate within HLA includes tolerance for engine oil condition and ambient temperature.
2. Noise when engine is started after setting one day or more.		
3. Noise when engine is started after new HLA is installed.	Oil leakage in HLA	
4. Noise during idle after warm up.	Insufficient oil pressure	Check oil pressure. If lower than specification, check for cause. (Refer to section D.)
	Faulty HLA	(Refer to page B2-14.) Press down HLA by hand. If it moves, replace HLA. If it does not move, HLA normal. Measure valve clearance.  FEELER GAUGE If more than 0.15 mm { 0.0059 in }, replace HLA.
5. Noise during idle after high speed running.	Incorrect oil amount	Check oil level. Drain or add oil as necessary.
	Deteriorated oil	Check oil quality. If deteriorated, replace with specified type and amount of oil.

FRONT OIL SEAL

PREPARATION

SST

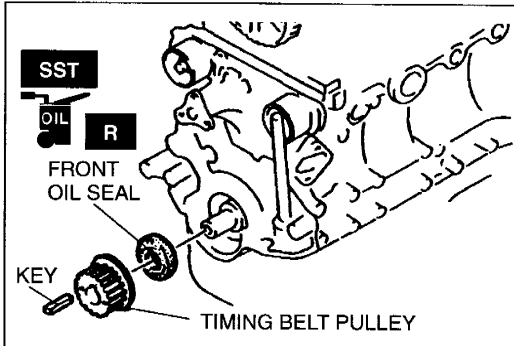
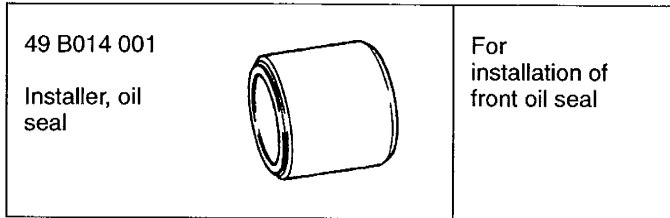

REPLACEMENT

1. Disconnect the negative battery cable.
2. Remove the timing belt. (Refer to page B2-5.)
3. Remove the timing belt pulley.
4. Remove the key.

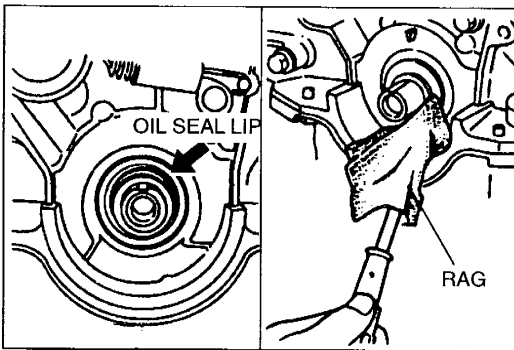

5. Cut the oil seal lip by using a razor knife.
6. Remove the oil seal by using a screwdriver protected with a rag.

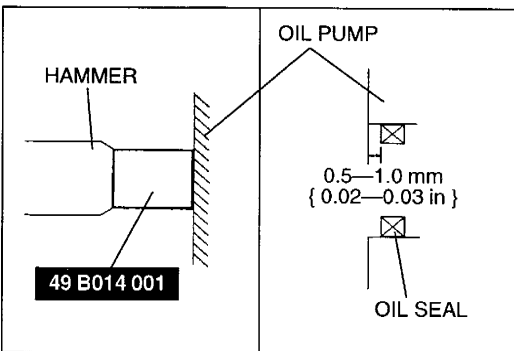

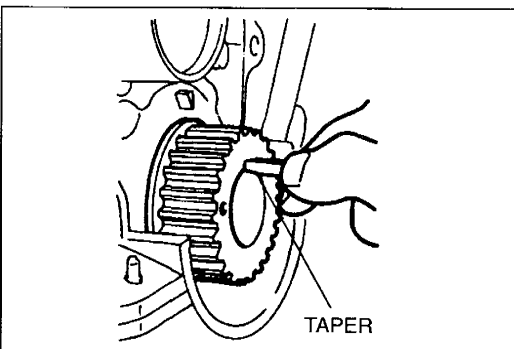

7. Apply clean engine oil to the new oil seal.
8. Push the oil seal slightly in by hand.
9. Tap the oil seal in evenly by using the **SST** and a hammer.



10. Install the timing belt pulley, aligning the key groove.
11. Insert the key with the tapered side toward the oil pump body.
12. Install the timing belt. (Refer to page B2-5.)
13. Connect the negative battery cable.
14. Start the engine and check the ignition timing. (Refer to section F2.)

REAR OIL SEAL

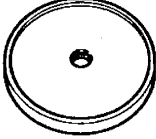
PREPARATION
SST

<p>49 W033 105</p> <p>Installer, oil seal</p> 	<p>For installation of rear oil seal</p>	<p>49 G030 795</p> <p>Installer, oil seal</p> 	<p>For installation of rear oil seal</p>
<p>49 G030 797</p> <p>Handle (Part of 49 G030 795)</p> 	<p>For installation of rear oil seal</p>	<p>—</p>	<p>—</p>

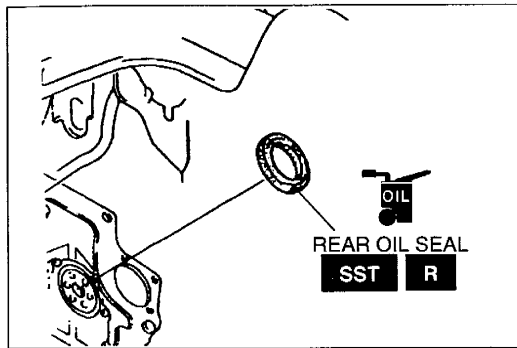

REPLACEMENT

1. Disconnect the negative battery cable.
2. Remove the transaxle assembly.
(Refer to section J, K.)
3. Remove the clutch cover and clutch disc (MTX).
(Refer to section H.)
4. Remove the flywheel (MTX) or drive plate (ATX).
(Refer to section J, K.)

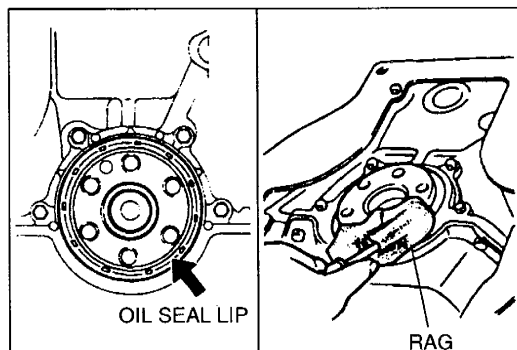

5. Cut the oil seal lip by using a razor knife.
6. Remove the oil seal by using a screwdriver protected with a rag.

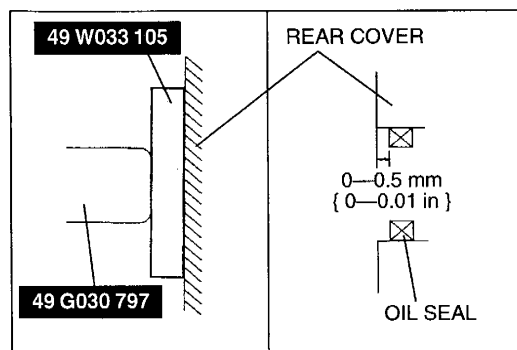

7. Apply clean engine oil to the new oil seal.
8. Push the oil seal slightly in by hand.
9. Tap the oil seal in evenly by using the **SST** and a hammer.
10. Install the flywheel (MTX) or drive plate (ATX).
(Refer to section J, K.)
11. Install the clutch disc and clutch cover (MTX).
(Refer to section H.)
12. Install the transaxle assembly.
(Refer to section J, K.)
13. Connect the negative battery cable.

ENGINE

PREPARATION
SST

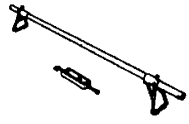
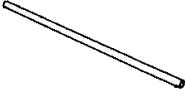
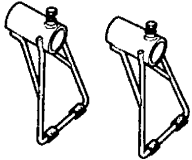
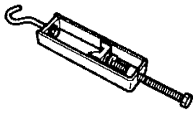
<p>49 G017 5A0</p> <p>Support, engine</p> 	<p>For support of engine</p>	<p>49 G017 501</p> <p>Bar (Part of 49 G017 5A0)</p> 	<p>For support of engine</p>
<p>49 G017 502</p> <p>Support (Part of 49 G017 5A0)</p> 	<p>For support of engine</p>	<p>49 G017 503</p> <p>Hook (Part of 49 G017 5A0)</p> 	<p>For support of engine</p>

REMOVAL / INSTALLATION

Procedure

Warning

- Fuel line spills and leaks are dangerous. Fuel can ignite and cause serious injuries or death and damage. Fuel can also irritate skin and eyes. To prevent this, always complete the “Fuel Line Safety Procedures” on section F2.
- Fuel vapor is hazardous. It can very easily ignite, causing serious injury and damage. Always keep sparks and flames away from fuel.

Caution

- Cover the fuel hoses with a rag because fuel will spray out when disconnected.

Note

- Plug the disconnected fuel hoses to prevent fuel leakage.

1. Disconnect the negative battery cable.
2. Drain the engine coolant. (Refer to section E.)
3. Remove the hood and front wheels.
4. Drain the transaxle oil. (Refer to section J, K.)
5. Remove the radiator. (Refer to section E.)
6. Remove the transverse member. (Refer to section R.)
7. Remove the front pipe and three way catalytic converter. (Refer to section F2.)
8. Remove the exhaust manifold. (Refer to section F2.)
9. Remove in the order shown in the figure, referring to **Removal Note**.
10. Install in the reverse order of removal, referring to **Installation Note**.
11. Install the exhaust manifold. (Refer to section F2.)
12. Install the front pipe and three way catalytic converter. (Refer to section F2.)
13. Install the transverse member. (Refer to section R.)
14. Install the radiator. (Refer to section E.)
15. Fill the transaxle with the specified amount and type of transaxle oil. (Refer to section J, K.)
16. Install the hood and front wheels.
17. Fill the radiator and radiator reservoir with the specified amount and type of engine coolant. (Refer to section E.)
18. Connect the negative battery cable.
19. Start the engine and
 - (1) check the engine oil, transaxle oil, and engine coolant leakage.
 - (2) check the ignition timing and idle speed. (Refer to section F2.)
20. Turn off the engine and check the drive belt deflection. (Refer to page B2–2.)
21. Perform a road test.
22. Recheck the engine oil, transaxle oil, and engine coolant levels.

Step 1

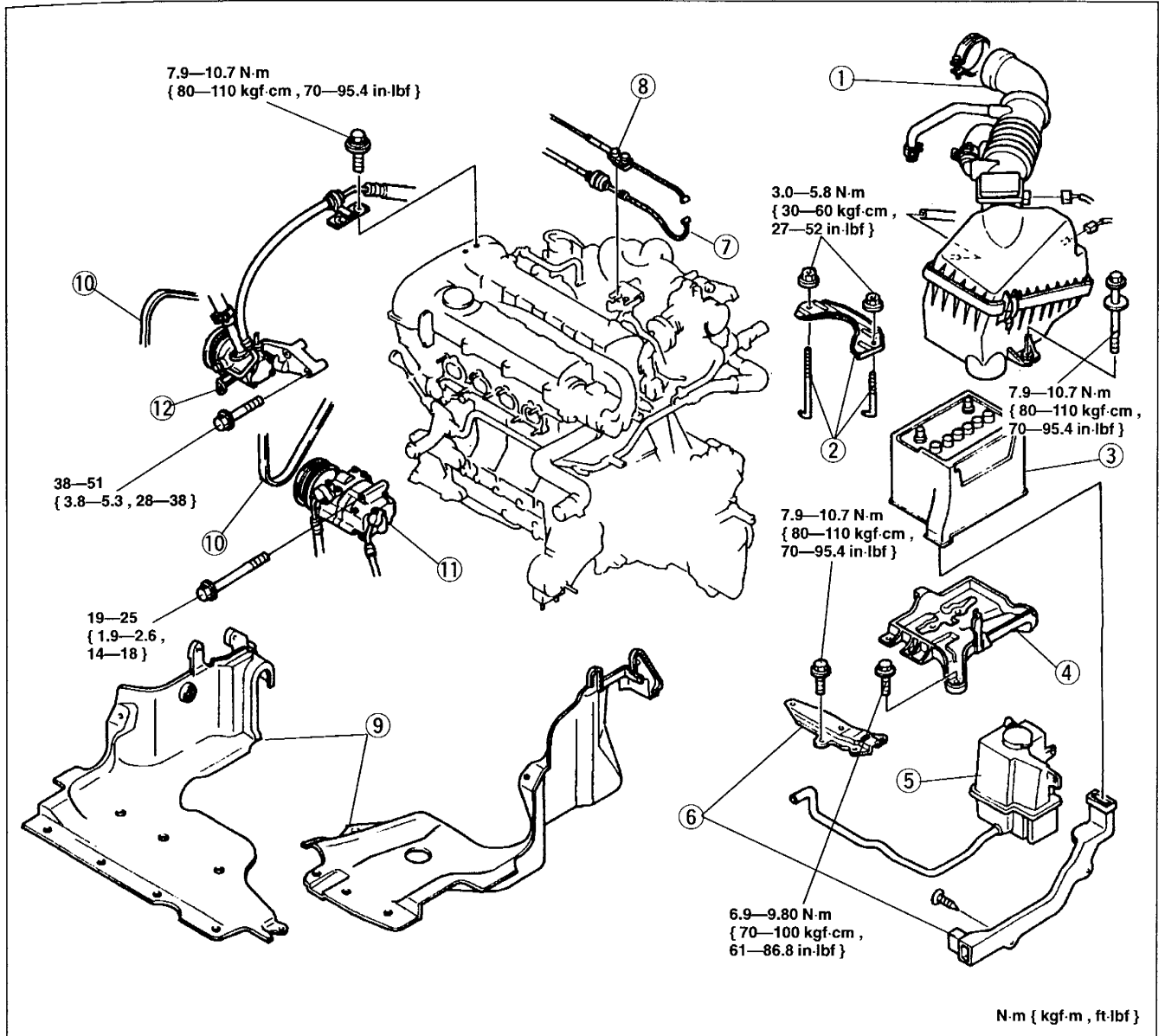

- | | |
|-----------------------------|----------------------------------|
| 1. Air cleaner | 8. Throttle cable (ATX) |
| 2. Battery clamp | Adjustment section K |
| 3. Battery | 9. Splash shield |
| 4. Battery carrier | 10. Drive belt |
| 5. Radiator reservoir | Adjustment page B2-3 |
| 6. Battery duct, bracket | 11. A/C compressor (if equipped) |
| 7. Accelerator cable | Removal Note below |
| Adjustment section F2 | 12. P/S oil pump |
| | Removal Note below |

Removal Note

A/C compressor (if equipped)

1. Remove the A/C compressor with the hoses still connected. (Refer to section U.)
2. Position the compressor away from the engine and affix it with wire.

P/S oil pump

1. Remove the P/S oil pump with the hoses still connected. (Refer to section N.)
2. Position the pump away from the engine and affix it with wire.

Step 2

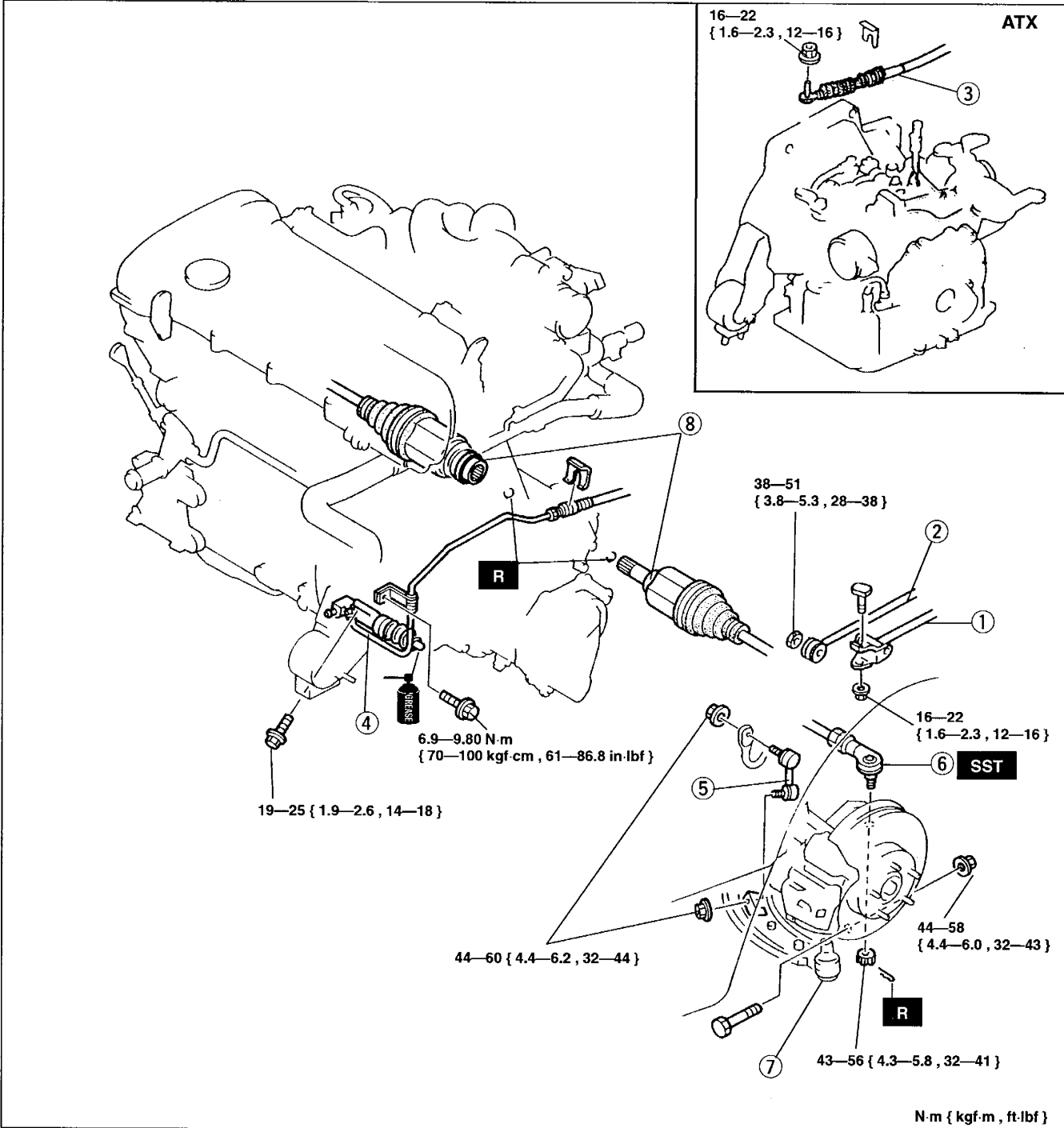

- 1. Control rod (MTX)
- 2. Extension bar (MTX)
- 3. Selector cable (ATX)
- 4. Clutch release cylinder (MTX)
Removal / Installation section H
- 5. Stabilizer control link

- 6. Outer ball joint
Removal / Installation section N
- 7. Lower arm
Removal / Installation section R
- 8. Drive shaft
Removal / Installation section M

Step 3

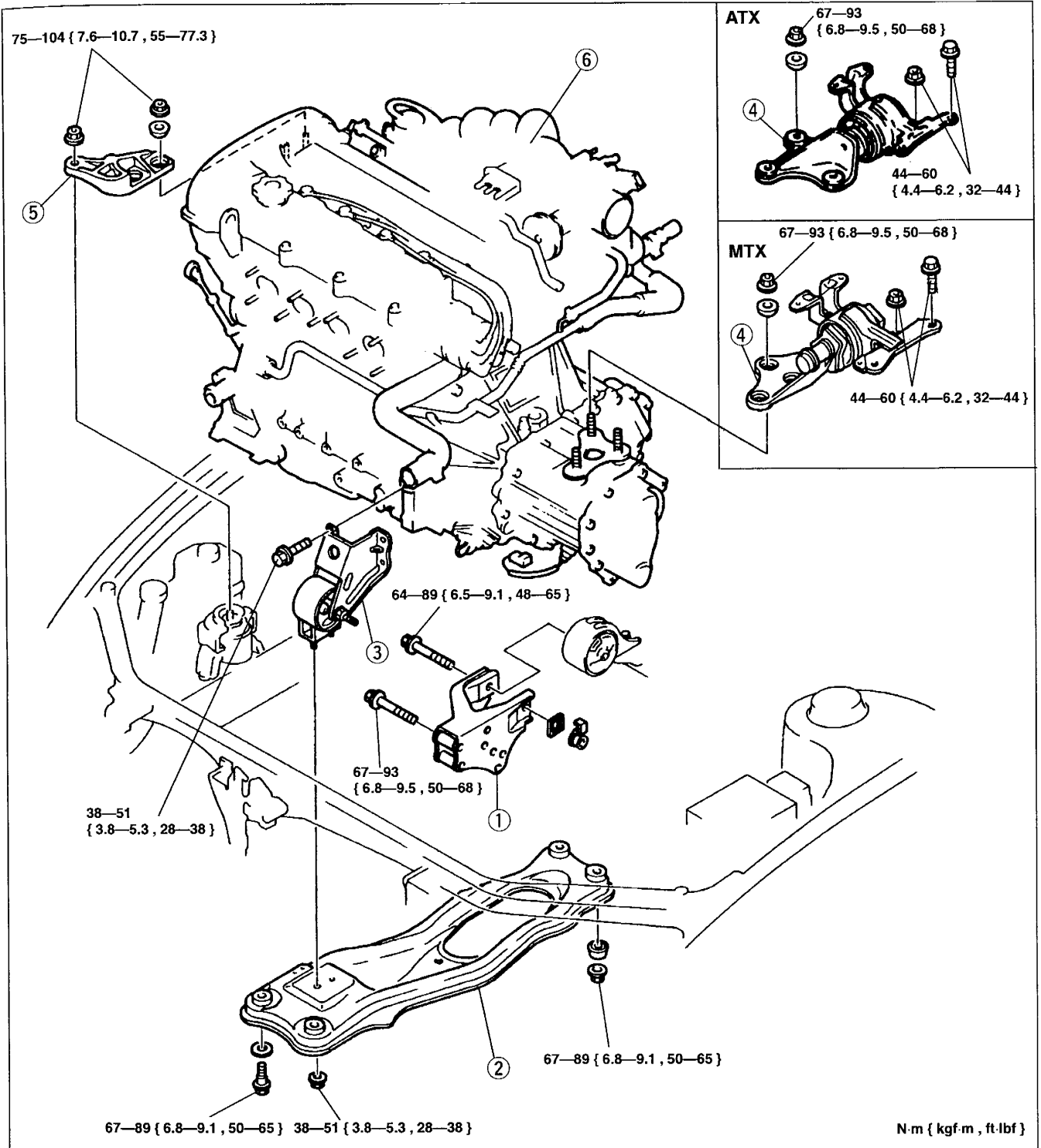

- 1. No.1 engine mount bracket
Removal Note page B2-24
Installation Note page B2-26
- 2. Engine mount member
Removal Note page B2-24
Installation Note page B2-26
- 3. No.2 engine mount bracket
Removal Note page B2-24
Installation Note page B2-25

- 4. No.4 engine mount bracket
Removal Note page B2-24
Installation Note page B2-25
- 5. No.3 engine mount bracket
Removal Note page B2-24
Installation Note page B2-25
- 6. Engine and transaxle assembly
Removal Note page B2-25
Installation Note page B2-25

N·m { kgf·m , ft·lbf }

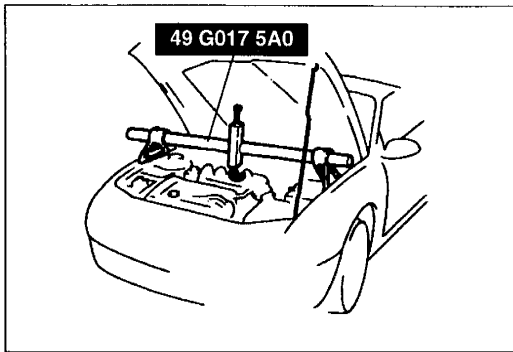

Removal Note

No.1 engine mount bracket

1. Support the engine by using the **SST**.
2. Remove the No.1 engine mount bracket.

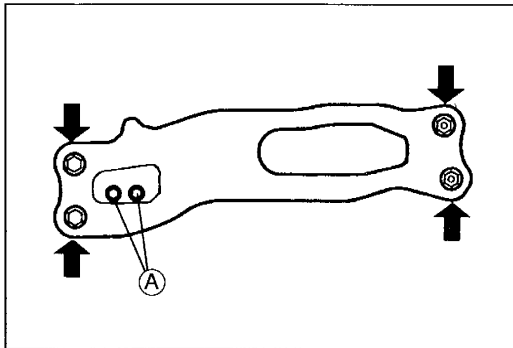

Engine mount member

1. Remove the No.2 engine mount nuts (A).
2. Remove the engine mount member bolts and nuts.
3. Remove the engine mount member.

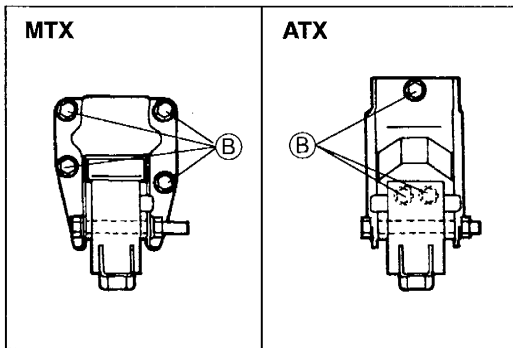

No.2 engine mount bracket

1. Remove the No.2 engine mount bracket bolts (B).
2. Remove the No.2 engine mount bracket.

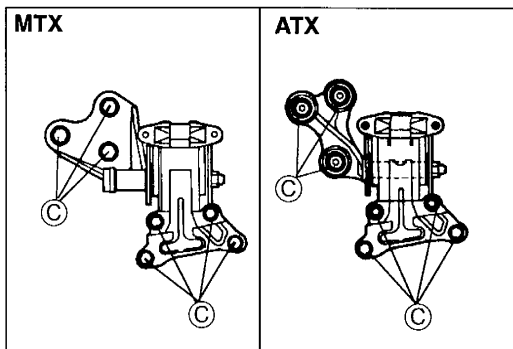

No.4 engine mount bracket

1. Remove the engine and transaxle assembly from the **SST** (Support, engine) and securely support it with the chain block.
2. Remove the No.4 engine mount bracket bolts and nuts marked (C).
3. Remove the No.4 engine mount bracket.

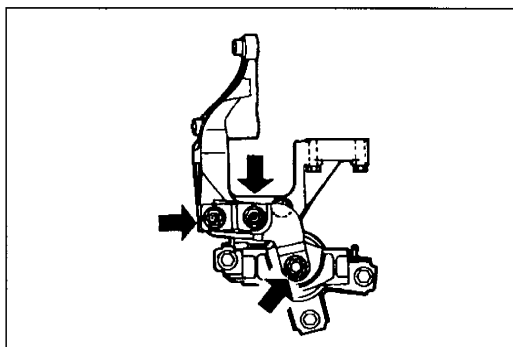

No.3 engine mount bracket

Remove the No.3 engine mount bracket nuts.

Engine and transaxle assembly

Slowly lift up the engine and transaxle assembly as a unit. Keep the engine from swinging or bumping into components in the engine compartment.

Installation Note

Engine and transaxle assembly

Slowly lower the engine and transaxle assembly as a unit. Keep the engine from swinging or bumping into components in the engine compartment.

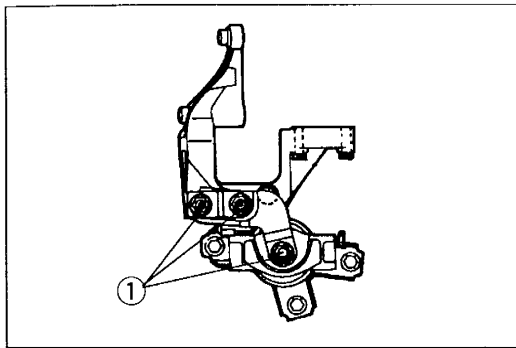

No.3 engine mount bracket

Hand tighten No.3 engine mount bracket nuts ①.

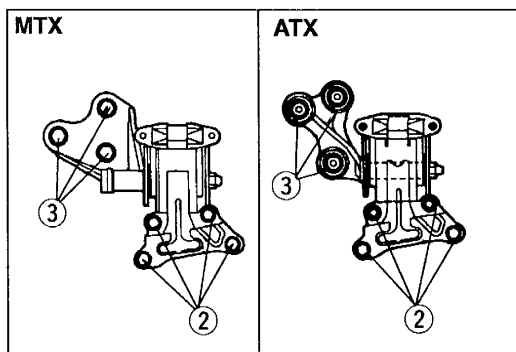

No.4 engine mount bracket

1. Hand tighten No.4 engine mount bracket bolts and nuts ②.
2. Hand tighten No.4 engine mount bracket nuts ③.

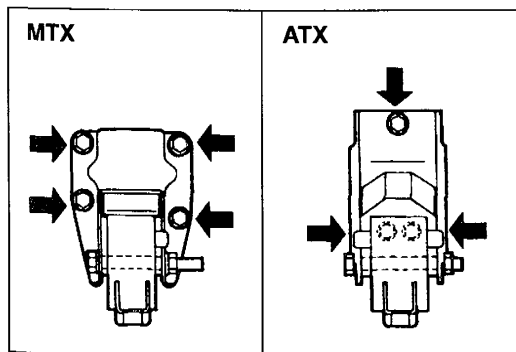

No.2 engine mount bracket

Install No.2 engine mount bracket.

Tightening torque:

38—51 N·m { 3.8—5.3 kgf·m , 28—38 ft·lbf }

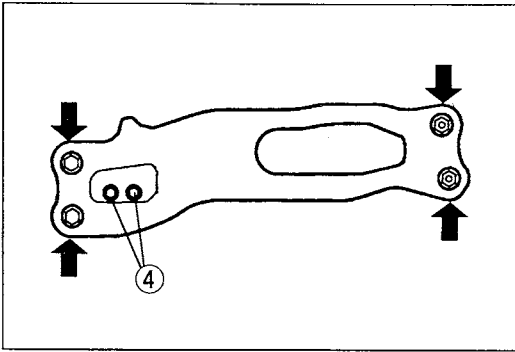

Engine mount member

1. Install the engine mount member.

Tightening torque:

67—89 N·m { 6.8—9.1 kgf·m , 50—65 ft·lbf }

2. Hand tighten No.2 engine mount nuts ④.

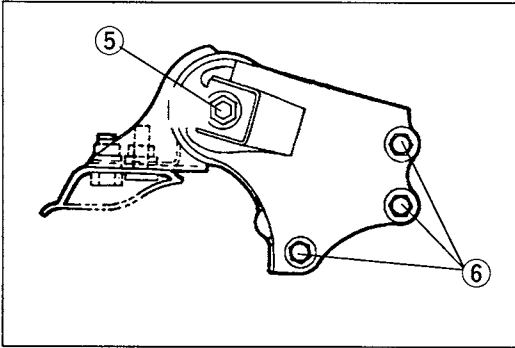

No.1 engine mount bracket

1. Tighten No.1 engine mount bracket bolts ⑤, ⑥.

Tightening torque

⑤: 64—89 N·m { 6.5—9.1 kgf·m , 48—65 ft·lbf }

⑥: 67—93 N·m { 6.8—9.5 kgf·m , 50—68 ft·lbf }

2. Remove the chain block.

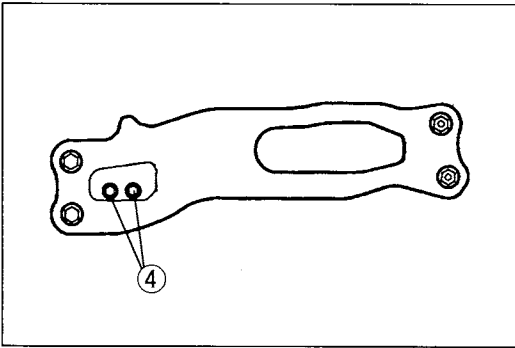

3. Tighten the engine mount bolts and nuts as follows.
 - (1) No.2 engine mount

Tightening torque

④: 38—51 N·m { 3.8—5.3 kgf·m , 28—38 ft·lbf }

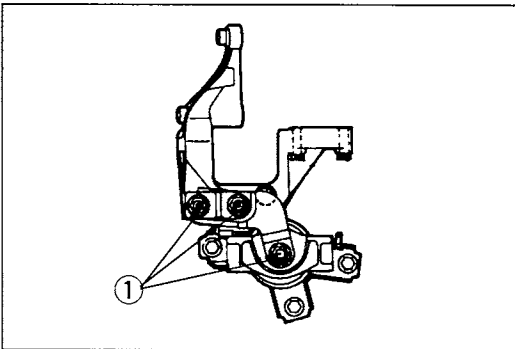

- (2) No.3 engine mount bracket

Tightening torque

①: 75—104 N·m

{ 7.6—10.7 kgf·m , 55—77.3 ft·lbf }

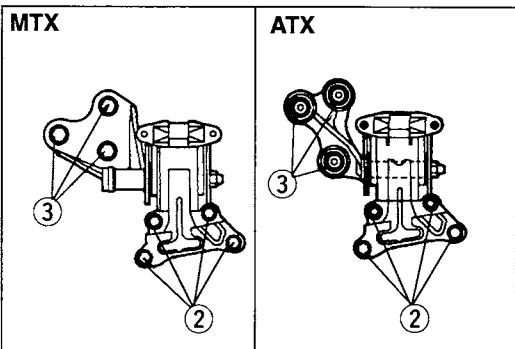

- (3) No.4 engine mount bracket

Tightening torque

②: 44—60 N·m { 4.4—6.2 kgf·m , 32—44 ft·lbf }

③: 67—93 N·m { 6.8—9.5 kgf·m , 50—68 ft·lbf }

DISASSEMBLY / ASSEMBLY

1. Disconnect the engine and transaxle. (Refer to section J, K.)
2. Remove the clutch cover and clutch disc (MTX). (Refer to section H.)
3. Remove the intake-air system and crankshaft position sensor. (Refer to section F2.)
4. Disassemble in the order shown in the figure.
5. Assemble in the reverse order of disassembly.
6. Install the intake-air system and crankshaft position sensor. (Refer to section F2.)
7. Install the clutch disc and clutch cover (MTX). (Refer to section H.)
8. Connect the engine and transaxle. (Refer to section J, K.)

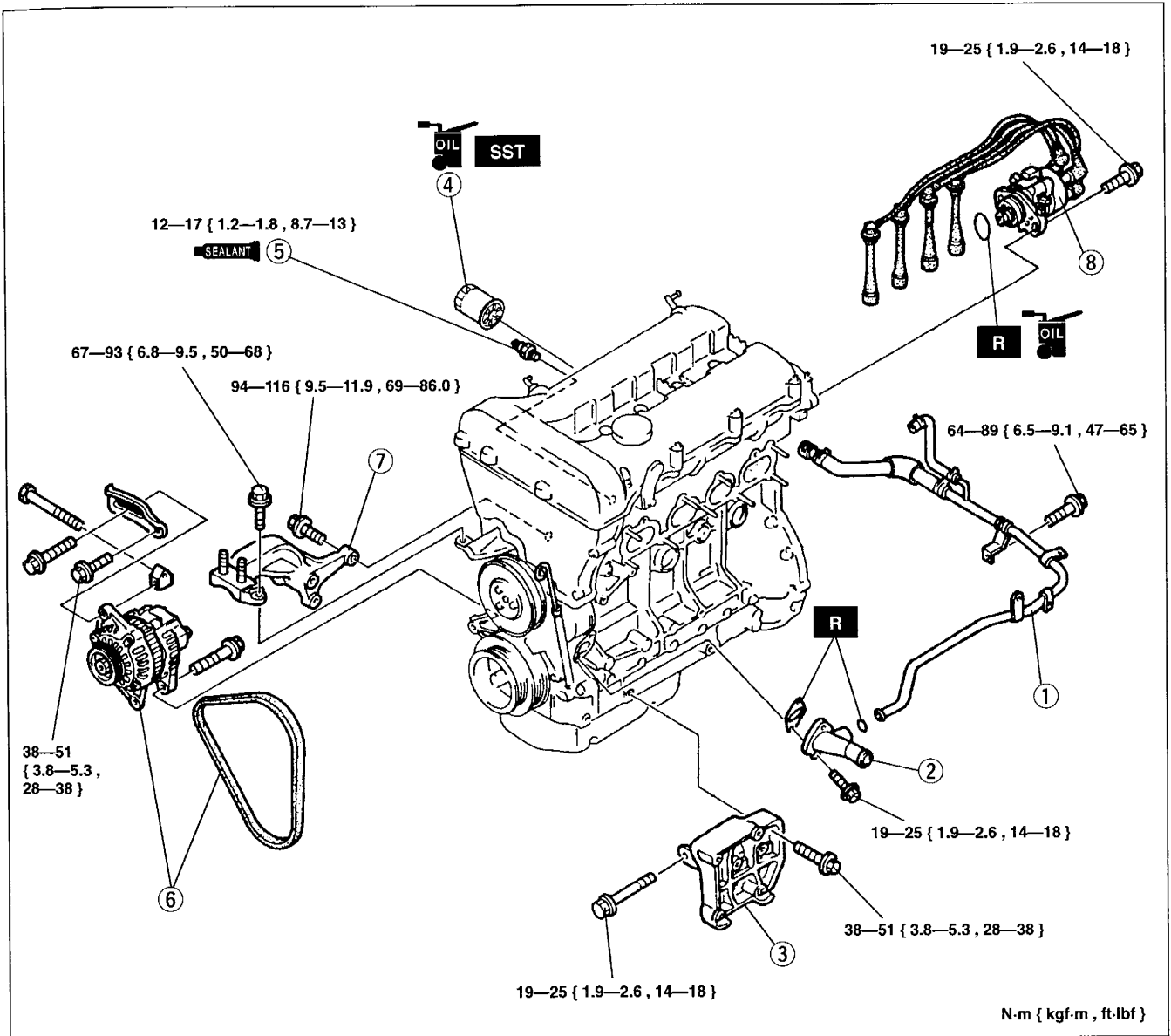

- | | |
|---|--|
| <ol style="list-style-type: none"> 1. Water bypass pipe 2. Water inlet pipe 3. A/C compressor bracket (if equipped) 4. Oil filter
Removal / Installation section D 5. Oil pressure switch
Removal / Installation section D | <ol style="list-style-type: none"> 6. Generator and drive belt
Adjustment page B2-3 7. No.3 engine mount 8. Distributor |
|---|--|

Before beginning any service procedure, refer to section T1 of this manual for air bag system service warnings.

LUBRICATION SYSTEM

OIL PRESSURE	D-2
PREPARATION	D-2
INSPECTION	D-2
ENGINE OIL	D-3
INSPECTION	D-3
REPLACEMENT	D-3
OIL FILTER	D-4
PREPARATION	D-4
REPLACEMENT	D-4
OIL PAN	D-4
REMOVAL / INSTALLATION	D-4

OIL PRESSURE

Warning

- Continuous exposure with USED engine oil has caused skin cancer in laboratory mice. Protect your skin by washing with soap and water immediately after this work.

PREPARATION**SST**

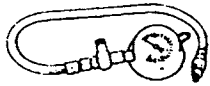
49 0187 280		For inspection of oil pressure
Gauge, oil pressure		

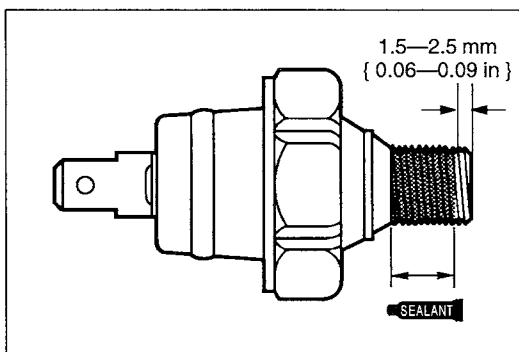
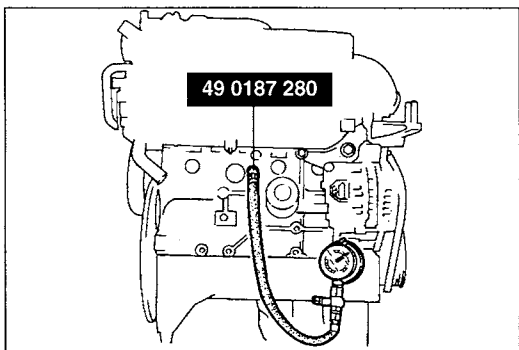
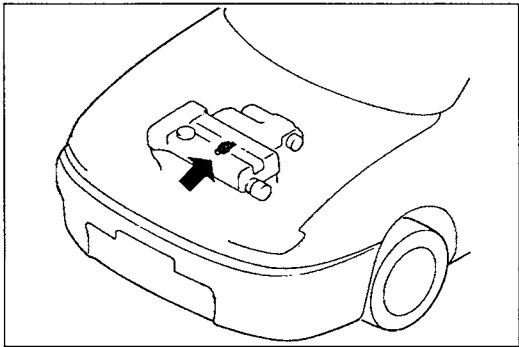
**INSPECTION**

1. Remove the oil pressure switch.
2. Screw the **SST** into the oil pressure switch installation hole.
3. Warm up the engine to normal operating temperature.
4. Run the engine at the specified speed, and note the gauge readings.

Note

- The oil pressure can vary with oil viscosity and temperature.

Oil pressure:

99—196 kPa { 1.0—2.0 kgf/cm² , 15—28 psi }
 –1000 rpm
 295—392 kPa { 3.0—4.0 kgf/cm² , 43—56 psi }
 –3000 rpm

5. If the pressure is not as specified, check for the cause and repair or replace as necessary.
6. Apply silicone sealant to the oil pressure switch threads as shown.
7. Remove the **SST** and install the oil pressure switch.

Tightening torque:

12—17 N·m { 1.2—1.8 kgf·m , 8.7—13 ft·lbf }

8. Start the engine and check for oil leaks.

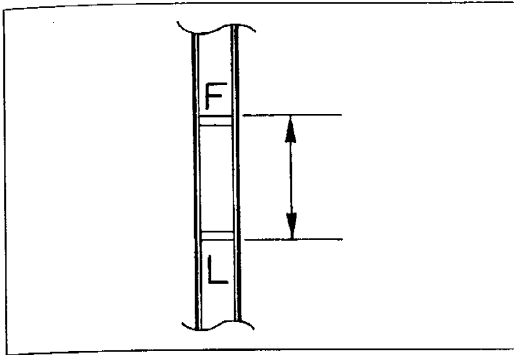

ENGINE OIL

INSPECTION

1. Position the vehicle on level ground.
2. Warm up the engine to normal operating temperature and stop it.
3. Wait for five minutes.
4. Remove the dipstick and check the oil level and condition.
5. Add or replace oil if necessary.

D

Note

- The distance between the L and F marks on the dipstick represents 0.8 L { 0.85 US qt , 0.70 Imp qt }.

REPLACEMENT

Warning

- When the engine and the engine oil are hot, they can badly burn. Don't burn yourself with either.
- A vehicle that is lifted but not securely supported on safety stands is dangerous. It can slip or fall, causing death or serious injury. Never work around or under a lifted vehicle if it is not securely supported on safety stands.
- Continuous exposure with USED engine oil has caused skin cancer in laboratory mice. Protect your skin by washing with soap and water immediately after this work.

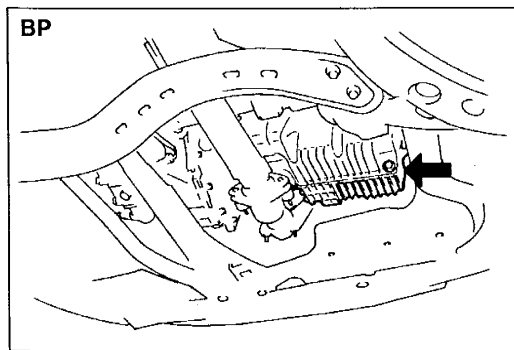
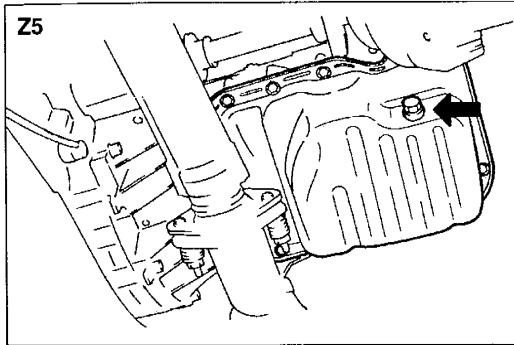

1. Remove the oil filler cap and the oil pan drain plug.
2. Drain the oil into a container.
3. Install the drain plug.

Tightening torque:

30—41 N·m { 3.0—4.2 kgf·m , 22—30 ft·lbf }

4. Refill the engine with the specified type and amount of engine oil.
5. Refit the oil filler cap.
6. Run the engine and check for oil leaks.
7. Check the oil level and add oil if necessary.

Note

- The actual oil level may vary from the specified capacity in some cases.

Oil capacity

L { US qt , Imp qt }

	Z5	BP
Oil replacement	3.2 { 3.4 , 2.8 }	3.6 { 3.8 , 3.2 }
Oil and oil filter replacement	3.5 { 3.7 , 3.1 }	3.8 { 4.0 , 3.3 }
Total (dry engine)	3.6 { 3.8 , 3.2 }	4.0 { 4.2 , 3.5 }

OIL FILTER

PREPARATION SST

<p>49 G014 001</p> <p>Wrench, oil filter</p>		<p>For removal / installation of oil filter</p>
--	---	---

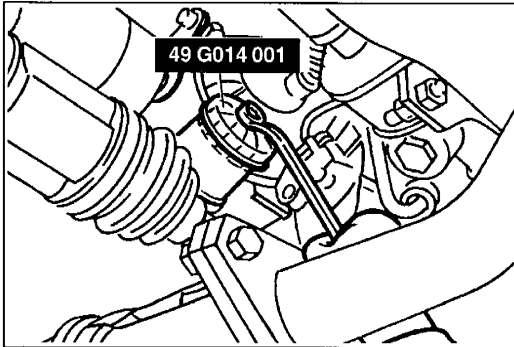

REPLACEMENT

1. Remove the oil filter by using the **SST**.
2. Use a clean rag to wipe off the mounting surface on the cylinder block.
3. Apply clean engine oil to the O-ring of the new oil filter.
4. Install the oil filter and tighten it by hand until the O-ring contacts the cylinder block.
5. Tighten the filter 1 and 1/6 turns by using the **SST**.

Note

- Tightening torque:
14—17 N·m { 1.4—1.8 kgf·m , 11—13 ft·lbf }

6. Start the engine and check for oil leaks.
7. Check the oil level and add oil if necessary.
(Refer to page D-3.)

OIL PAN

REMOVAL / INSTALLATION

1. Disconnect the negative battery cable.
2. Drain the engine oil. (Refer to page D-3.)
3. Remove the splash shield (RH).
4. Remove the transverse member. (BP) (Refer to section R.)
5. Remove the front pipe and three way catalytic converter. (Refer to section F1, F2.)
6. Remove in the order shown in the figure, referring to **Removal Note**.
7. Install in the reverse order of removal, referring to **Installation Note**.
8. Install the front pipe and three way catalytic converter. (Refer to section F1, F2.)
9. Install the transverse member. (BP) (Refer to section R.)
10. Install the splash shield (RH).
11. Fill with the specified amount and type of engine oil. (Refer to page D-3.)
12. Connect the negative battery cable.
13. Start the engine and check for oil leaks.
14. Turn off the engine and check the oil level.

Z5

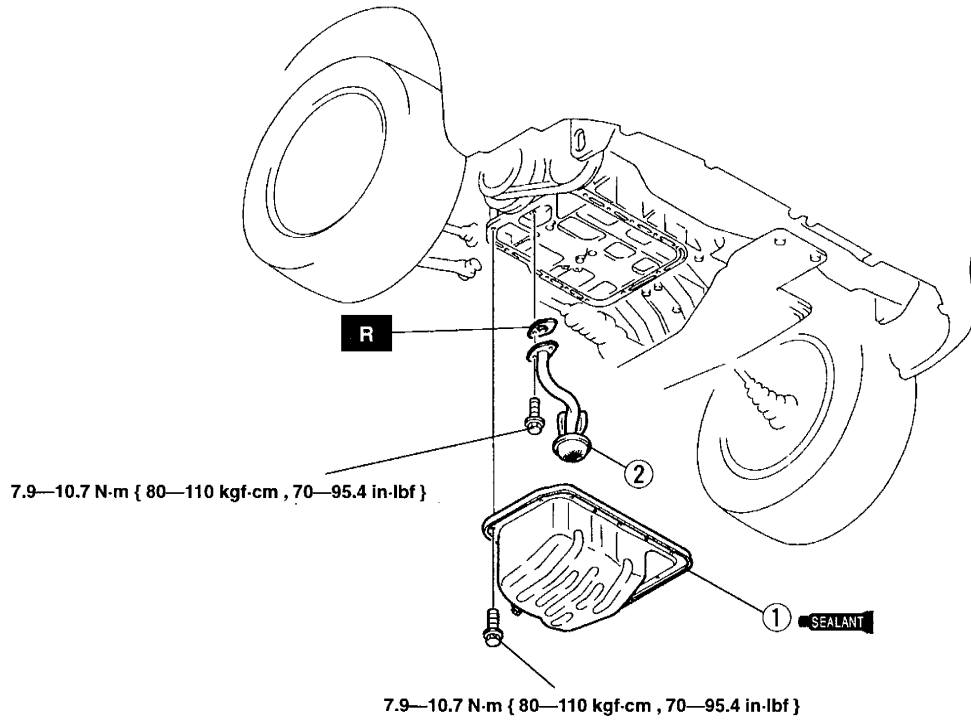

BP

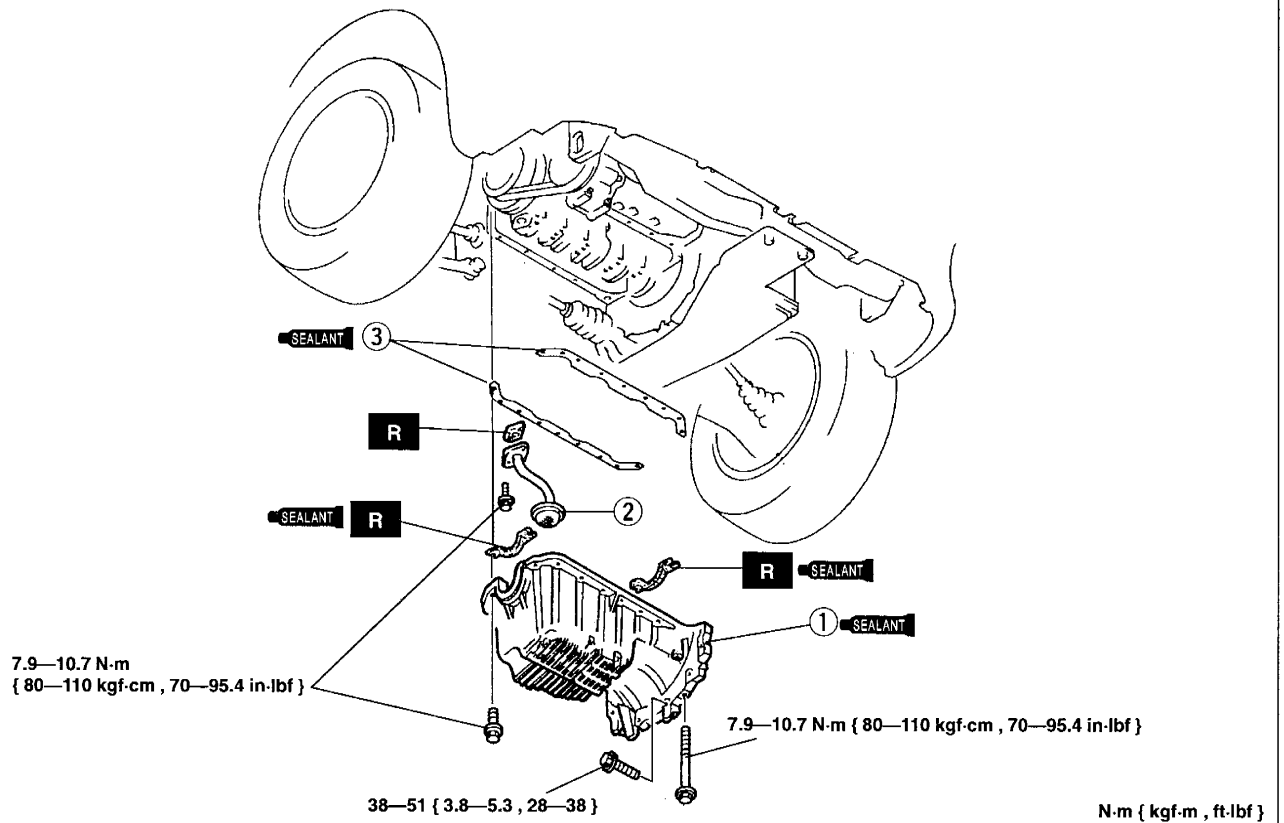

- 1. Oil pan
Removal Note page D-6
Installation Note page D-7
- 2. Oil strainer

- 3. Stiffener (BP)
Removal Note page D-6
Installation Note page D-7

Removal Note**Oil pan****Caution**

- Pry tools can easily scratch the oil pan mounting surfaces. Prying off the oil pan can also easily bend the oil pan flange. Refer to the following instructions before removing the oil pan.

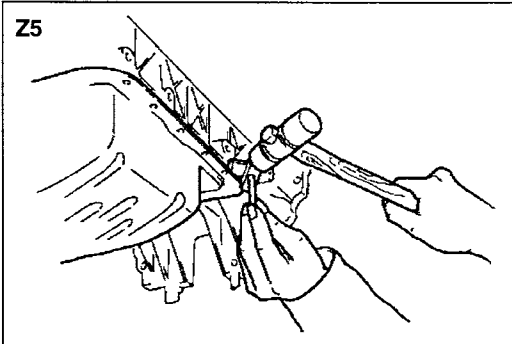
**(Z5)**

1. Remove the oil pan mounting bolts.
2. Insert a screwdriver or a seal cutter between the VRAS and oil pan.
3. Remove the oil pan.

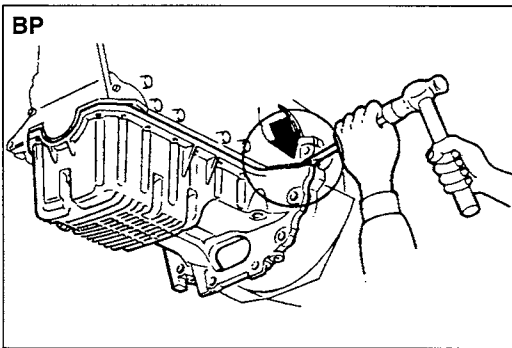
**(BP)**

1. Remove the oil pan mounting bolts.
2. Insert a screwdriver only at the points shown in the figure.
3. Remove the oil pan.

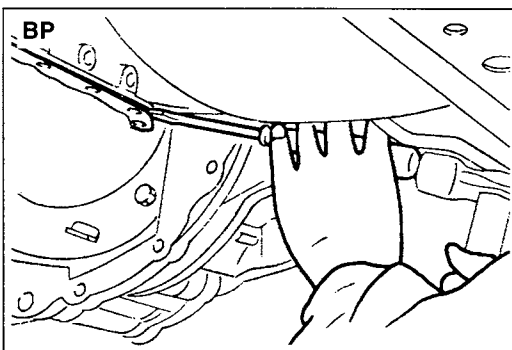
**Stiffener****(BP)**

1. Insert a screwdriver or a seal cutter between the stiffener and cylinder block.
2. Remove the stiffener.

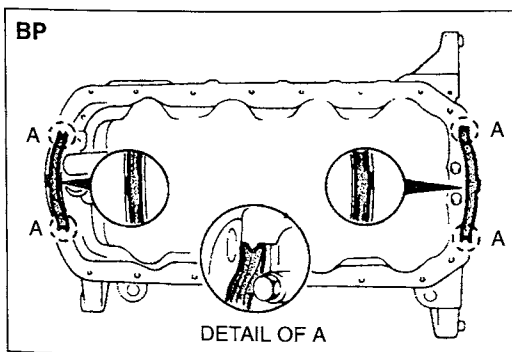
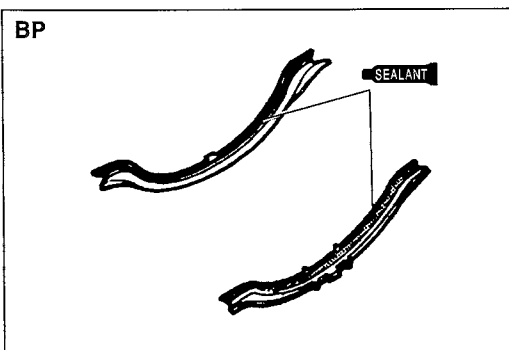
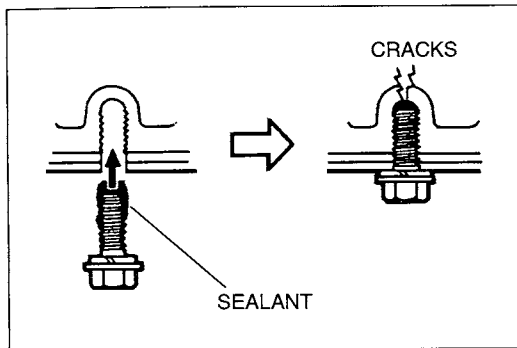
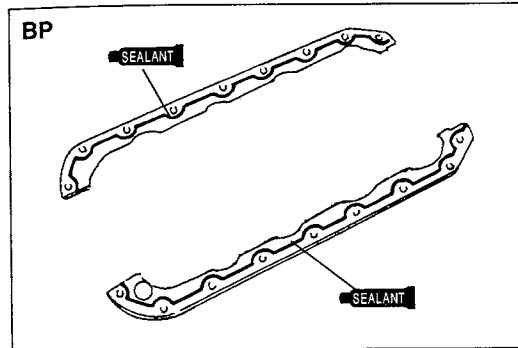
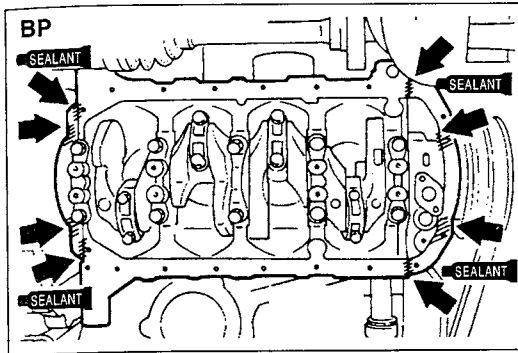

Installation Note Stiffener (BP)

1. Remove all foreign material from the contact surfaces of the cylinder block and stiffener.
2. Apply silicone sealant to the shaded areas of the cylinder block as shown.

D

3. Apply silicone sealant to the stiffener along the inside of the bolt holes.
4. Install the stiffener before sealant hardens.

Thickness: ϕ 2.5—3.5 mm { 0.099—0.137 in }

Oil pan

Caution

- If the bolts are reused, remove the old sealant from the bolt threads. Tightening a bolt that has old sealant on it can cause thread damage.

1. Apply silicone sealant to the contact surfaces of new oil pan gaskets as shown. (BP)

2. Install the new gaskets onto the oil pump body and the rear cover with the projections in the notches as shown. (BP)

D

OIL PAN

BP

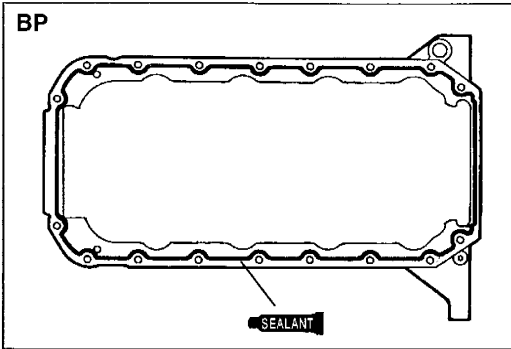

3. Apply silicone sealant to the oil pan along the inside of the bolt holes and overlap the ends.
4. Install the oil pan before sealant hardens.

Thickness: ϕ 2.5—3.5 mm { 0.099—0.137 in } (BP)
 ϕ 2.0—3.0 mm { 0.079—0.118 in } (Z5)

Tightening torque: 7.9—10.7 N·m
{ 80—110 kgf·cm , 70—95.4 in·lbf }

Z5

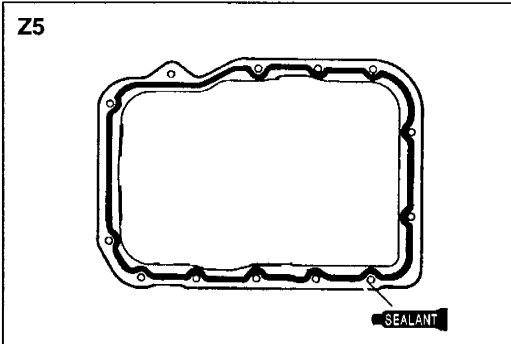

Before beginning any service procedure, refer to section T1 of this manual for air bag system service warnings.





COOLING SYSTEM

ENGINE COOLANT	E- 2
PREPARATION	E- 2
INSPECTION	E- 2
REPLACEMENT	E- 3
RADIATOR CAP	E- 5
PREPARATION	E- 5
INSPECTION	E- 5
RADIATOR	E- 6
REMOVAL / INSTALLATION	E- 6
THERMOSTAT	E- 7
REMOVAL / INSPECTION / INSTALLATION	E- 7
WATER PUMP	E- 9
REMOVAL / INSTALLATION	E- 9
COOLING FAN MOTOR	E-10
INSPECTION	E-10
REPLACEMENT	E-10
COOLING FAN RELAY	E-11
INSPECTION	E-11

ENGINE COOLANT

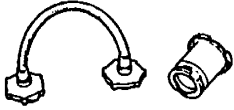
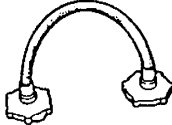
PREPARATION

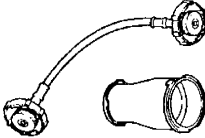
SST

49 9200 145 Adapter set, radiator cap tester		For inspection of cooling system (ATX)	49 9200 146 Adapter (Part of 49 9200 145)		For inspection of cooling system (ATX)
49 9200 147 Adapter (Part of 49 9200 145)		For inspection of cooling system (ATX)	49 D015 0A0 Adapter set, radiator cap tester		For inspection of cooling system (MTX)
49 D015 002 Adapter (Part of 49 D015 0A0)		For inspection of cooling system (MTX)	49 D015 003 Adapter (Part of 49 D015 0A0)		For inspection of cooling system (MTX)

INSPECTION

Warning

- Removing the radiator cap or the radiator drain plug while the engine is running, or when the engine and radiator are hot is dangerous. Scalding coolant and steam may shoot out and cause serious injury. It may also damage the engine and cooling system.
- Turn off the engine and wait until it is cool. Even then, be very careful when removing the cap. Wrap a thick cloth around it and slowly turn it counterclockwise to the first stop. Step back while the pressure escapes.
- When you're sure all the pressure is gone, press down on the cap—still using a cloth—turn it, and remove it.

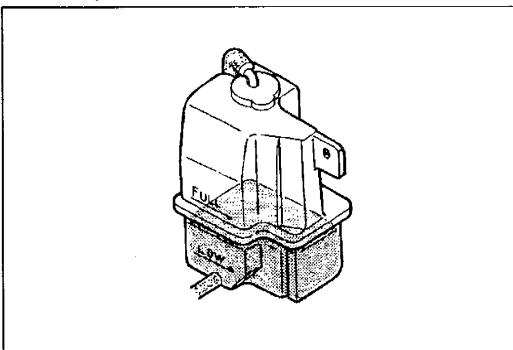

Coolant Level (Engine cold)

1. Verify that the coolant level in the radiator reservoir is between the FULL and LOW marks.
2. Add coolant if necessary.

Note

- The distance between the FULL and LOW marks on the radiator reservoir represents 0.45 L { 0.48 US qt , 0.40 Imp qt }.

Coolant Leakage

1. Remove the radiator cap.
2. Connect a radiator cap tester and the SST to the radiator filler neck.
3. Apply 103 kPa { 1.05 kgf/cm² , 15 psi } pressure to the system.

Caution

- Applying more than 103 kPa { 1.05 kgf/cm² , 15 psi } can damage the hoses, fittings, and other components, and cause leaks.
4. Verify that the pressure is held. If not, check the system for coolant leakage.

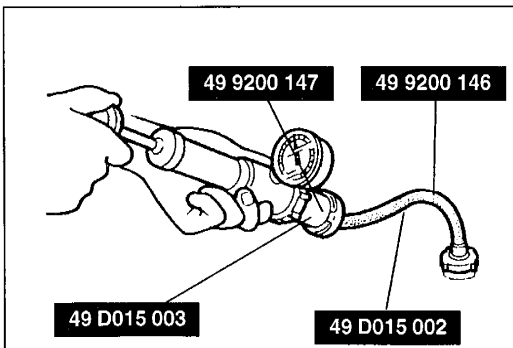

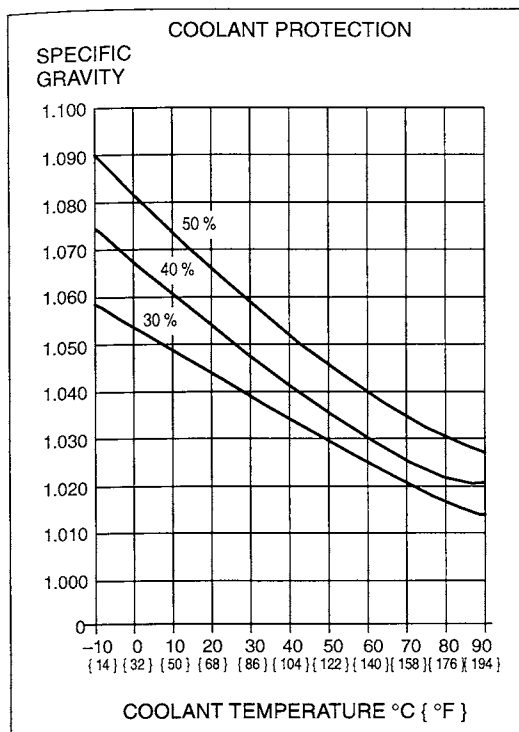

Coolant Protection

Caution

- The engine has aluminum parts that can be damaged by alcohol or methanol antifreeze. Do not use alcohol or methanol in the cooling system. Use only ethylene-glycol-based coolant.
- Use only soft (demineralized) water in the coolant mixture. Water that contains minerals will cut down on the coolant's effectiveness.

E

1. Measure the coolant temperature and specific gravity with a thermometer and a hydrometer.
2. Determine the coolant protection by referring to the graph shown.
3. If the coolant protection is not proper, add water or coolant as necessary.

Antifreeze solution mixture percentage

Coolant protection	Volume percentage		Gravity at 20 °C { 68 °F }
	Water	Coolant	
Above -16 °C { 3 °F }	65	35	1.054
Above -26 °C { -15 °F }	55	45	1.066
Above -40 °C { -40 °F }	45	55	1.078

REPLACEMENT

Draining

Warning

- Removing the radiator cap or the radiator drain plug while the engine is running, or when the engine and radiator are hot is dangerous. Scalding coolant and steam may shoot out and cause serious injury. It may also damage the engine and cooling system.
- Turn off the engine and wait until it is cool. Even then, be very careful when removing the cap. Wrap a thick cloth around it and slowly turn it counterclockwise to the first stop. Step back while the pressure escapes.
- When you're sure all the pressure is gone, press down on the cap—still using a cloth—turn it, and remove it.

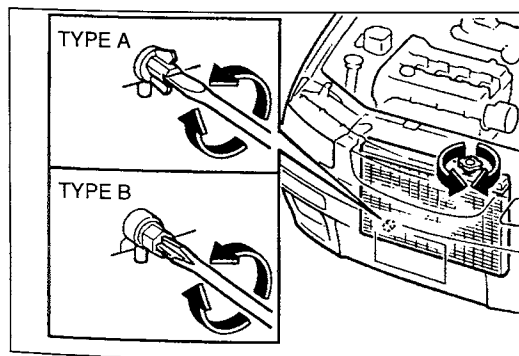

1. Remove the radiator cap and loosen the radiator drain plug.
2. Drain the coolant into a container.

3. Flush the cooling system with water until all traces of color are gone.
4. Left the system drain completely.
5. Tighten the radiator drain plug.

Tightening torque:

0.7—1.1 N·m { 7.0—12 kgf·cm , 6.1—10 in·lbf }

Refilling

Use the proper amount and mixture of ethylene-glycol-based coolant. (Refer to Coolant Protection, page E-3.)

1. Slowly pour the coolant into the radiator up to the coolant filler port.

Filling pace: 1.0 L { 1.1 US qt , 0.9 Imp qt }/min. max.





2. Fill the radiator reservoir up to the FULL mark.
3. Fully install the radiator cap.
4. Start the engine and let it idle until it warms up.
5. If the temperature increases beyond normal, there is excessive air in the system. Stop the engine and allow it to cool; then repeat steps 1—3.
6. Run the engine at 2,200—2,800 rpm for five minutes; repeat several times.
7. Stop the engine and allow it to cool.

Warning

- **Removing the radiator cap or the radiator drain plug while the engine is running, or when the engine and radiator are hot is dangerous. Scalding coolant and steam may shoot out and cause serious injury. It may also damage the engine and cooling system.**
 - **Turn off the engine and wait until it is cool. Even then, be very careful when removing the cap. Wrap a thick cloth around it and slowly turn it counterclockwise to the first stop. Step back while the pressure escapes.**
 - **When you're sure all the pressure is gone, press down on the cap—still using a cloth—turn it, and remove it.**
8. Check the coolant level. If the coolant level has dropped, repeat the procedure from step 1.

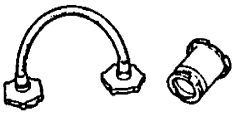
RADIATOR CAP

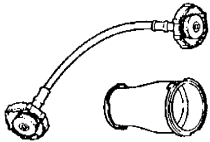
PREPARATION
SST

<p>49 9200 145</p> <p>Adapter set, radiator cap tester</p> 	<p>For inspection of radiator cap valve (ATX)</p>	<p>49 9200 147</p> <p>Adapter (Part of 49 9200 145)</p> 	<p>For inspection of radiator cap valve (ATX)</p>
<p>49 D015 0A0</p> <p>Adapter set, radiator cap tester</p> 	<p>For inspection of radiator cap valve (MTX)</p>	<p>49 D015 003</p> <p>Adapter (Part of 49 D015 0A0)</p> 	<p>For inspection of radiator cap valve (MTX)</p>

E

Warning

- Removing the radiator cap or the radiator drain plug while the engine is running, or when the engine and radiator are hot is dangerous. Scalding coolant and steam may shoot out and cause serious injury. It may also damage the engine and cooling system.
- Turn off the engine and wait until it is cool. Even then, be very careful when removing the cap. Wrap a thick cloth around it and slowly turn it counterclockwise to the first stop. Step back while the pressure escapes.
- When you're sure all the pressure is gone, press down on the cap—still using a cloth—turn it, and remove it.

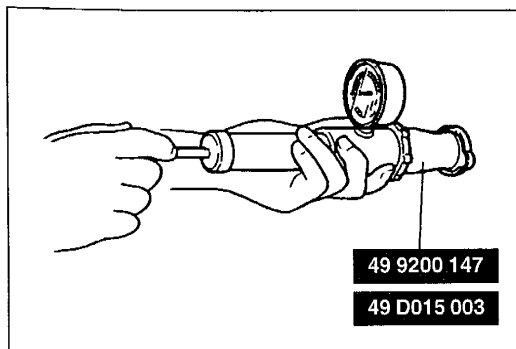

INSPECTION

Radiator Cap Valve

1. Remove the radiator cap.
2. Attach the radiator cap to a radiator cap tester with the SST. Apply pressure gradually to 74—102 kPa { 0.75—1.05 kgf/cm², 11—14.9 psi }.
3. Verify that the pressure is held for at least 10 seconds.

RADIATOR

REMOVAL / INSTALLATION

1. Disconnect the negative battery cable.
2. Drain the engine coolant. (Refer to page E-3.)
3. Remove the radiator grille. (Refer to section S1.)
4. Remove in the order shown in the figure, referring to **Removal Note**.
5. Install in the reverse order of removal, referring to **Installation Note**.
6. Install the radiator grille. (Refer to section S1.)
7. Fill the radiator and radiator reservoir with the specified amount and type of engine coolant. (Refer to page E-3.)
8. Check the ATF level and add ATF if necessary. (Refer to section K.)
9. Check the ATF and coolant leaks.

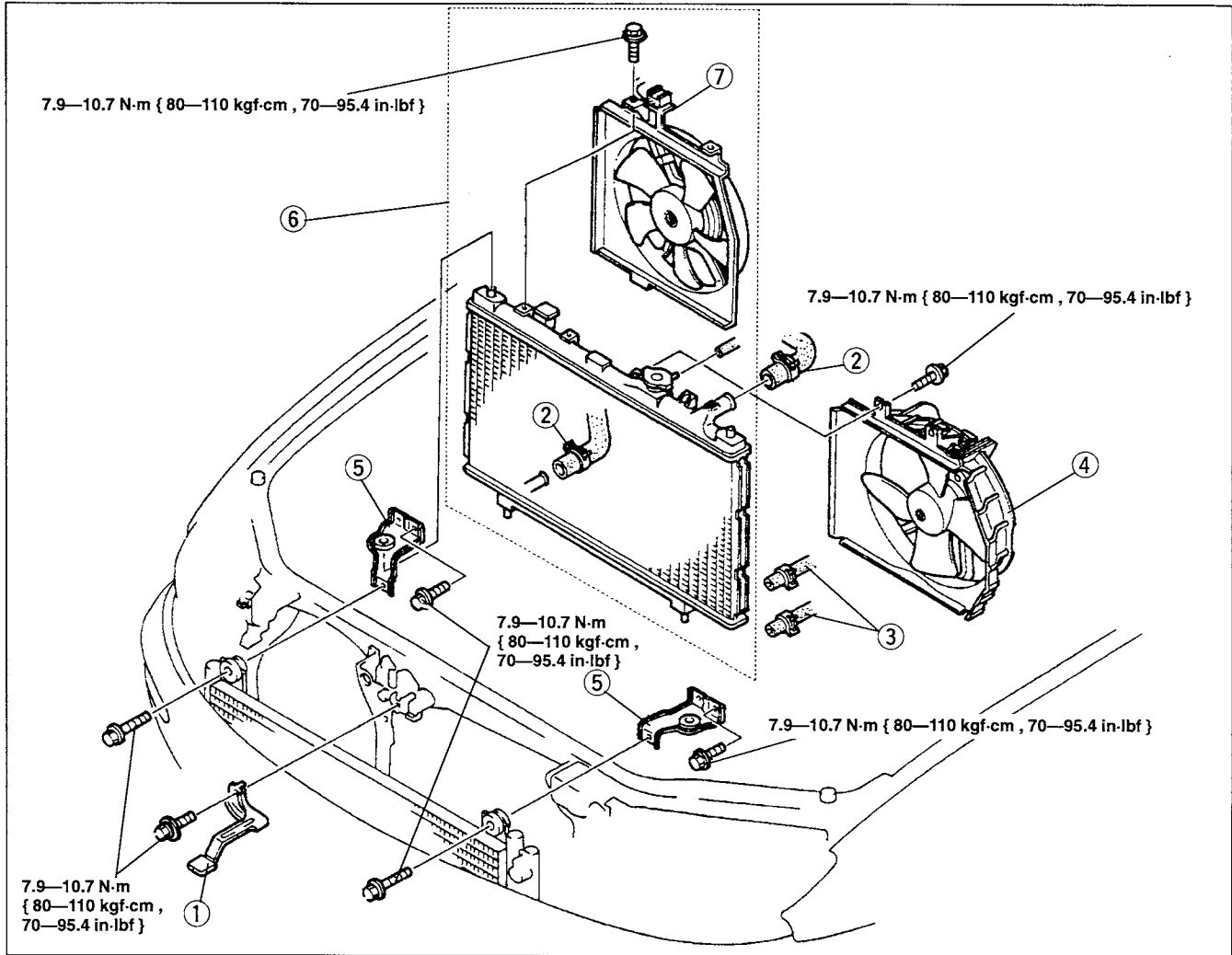

- | | |
|--|--|
| <ol style="list-style-type: none"> 1. Safety lever 2. Radiator hose 3. Oil hose (ATX)
Installation Note section K 4. Cooling fan assembly
Removal Note below | <ol style="list-style-type: none"> 5. Radiator bracket 6. Radiator assembly 7. Condenser fan assembly (if equipped) |
|--|--|

Removal Note

Cooling fan assembly

1. Move the cooling fan assembly to the engine side for easy removal of the radiator.
2. Remove the radiator, and then remove the cooling fan assembly.

THERMOSTAT

REMOVAL / INSPECTION / INSTALLATION

1. Disconnect the negative battery cable.
2. Drain the engine coolant. (Refer to page E-3.)
3. Remove the air cleaner. (Refer to section F1, F2.)
4. Remove in the order shown in the figure.
5. Install in the reverse order of removal, referring to **Installation Note**.
6. Install the air cleaner. (Refer to section F1, F2.)
7. Fill the radiator and radiator reservoir with the specified amount and type of engine coolant. (Refer to page E-3, 4.)
8. Connect the negative battery cable.
9. Start the engine and check for coolant leaks.

E

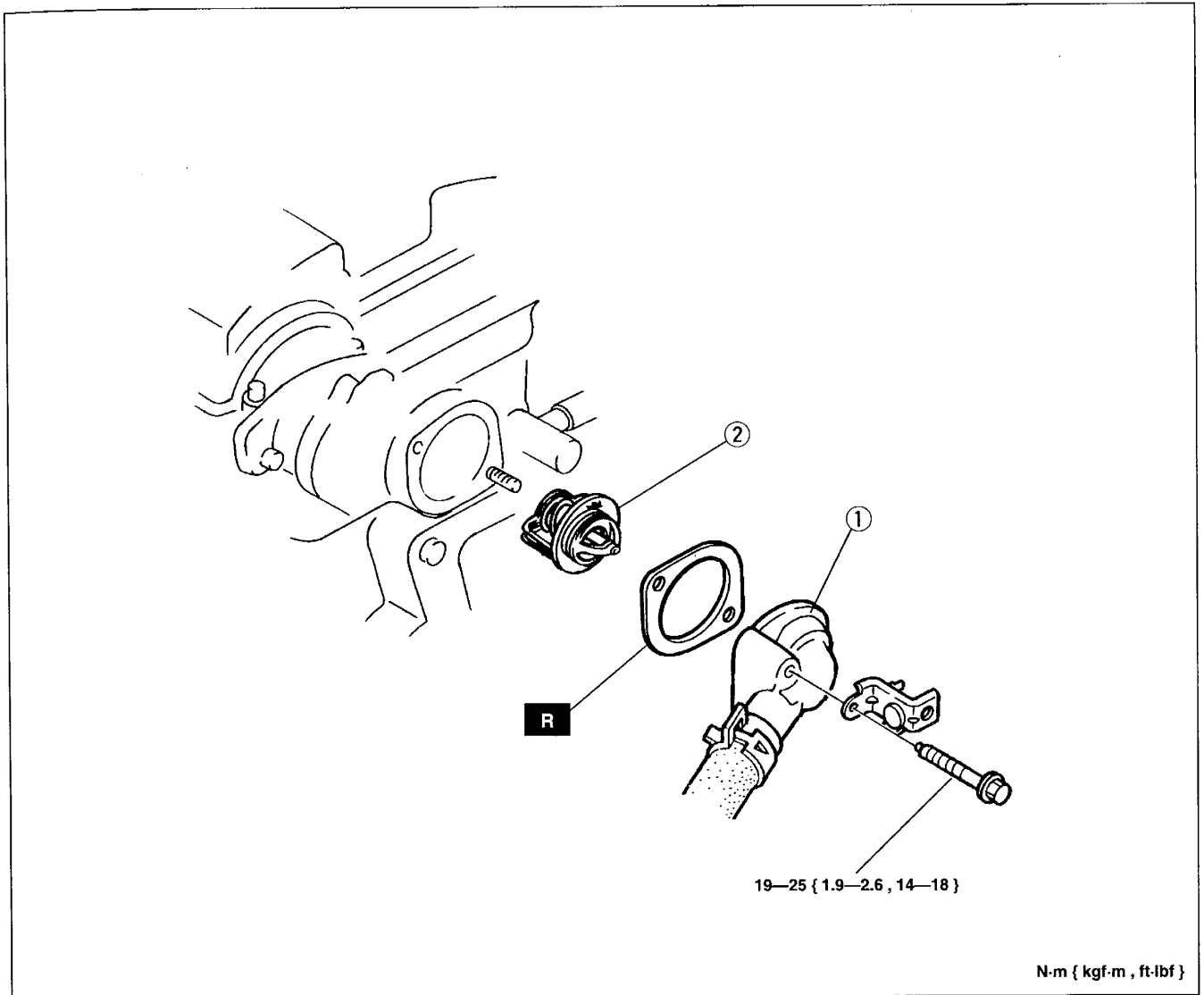

1. Thermostat cover

2. Thermostat
 Inspection page E-8
 Installation Note page E-8

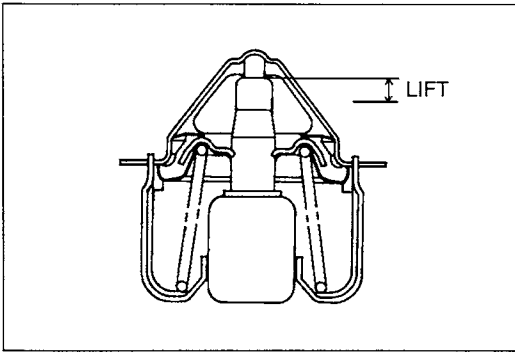

Inspection Thermostat

1. Visually check that the thermostat valve is airtight.
2. Place the thermostat and a thermometer in water.
3. Heat the water gradually and check the following.

Initial-opening temperature:

83.5—89.5 °C { 188—193 °F }

Full-open temperature: 100 °C { 212 °F }

Full-open lift: 8.0 mm { 0.31 in } min.

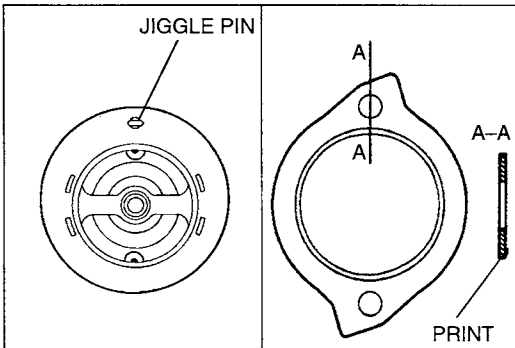

Installation Note Thermostat

1. Install the thermostat into the cylinder head with the jiggle pin at the top.
2. Install a new gasket with the seal print side facing the cylinder head.

WATER PUMP

REMOVAL / INSTALLATION

1. Disconnect the negative battery cable.
2. Drain the coolant. (Refer to page E-3.)
3. Remove the timing belt. (Refer to section B1, B2.)
4. Remove in the order shown in the figure.
5. Install in the reverse order of removal.
6. Install the timing belt. (Refer to section B1, B2.)
7. Fill the radiator and radiator reservoir with the specified amount and type of engine coolant. (Refer to page E-3.)
8. Connect the negative battery cable.
9. Start the engine and check for coolant leaks.

E

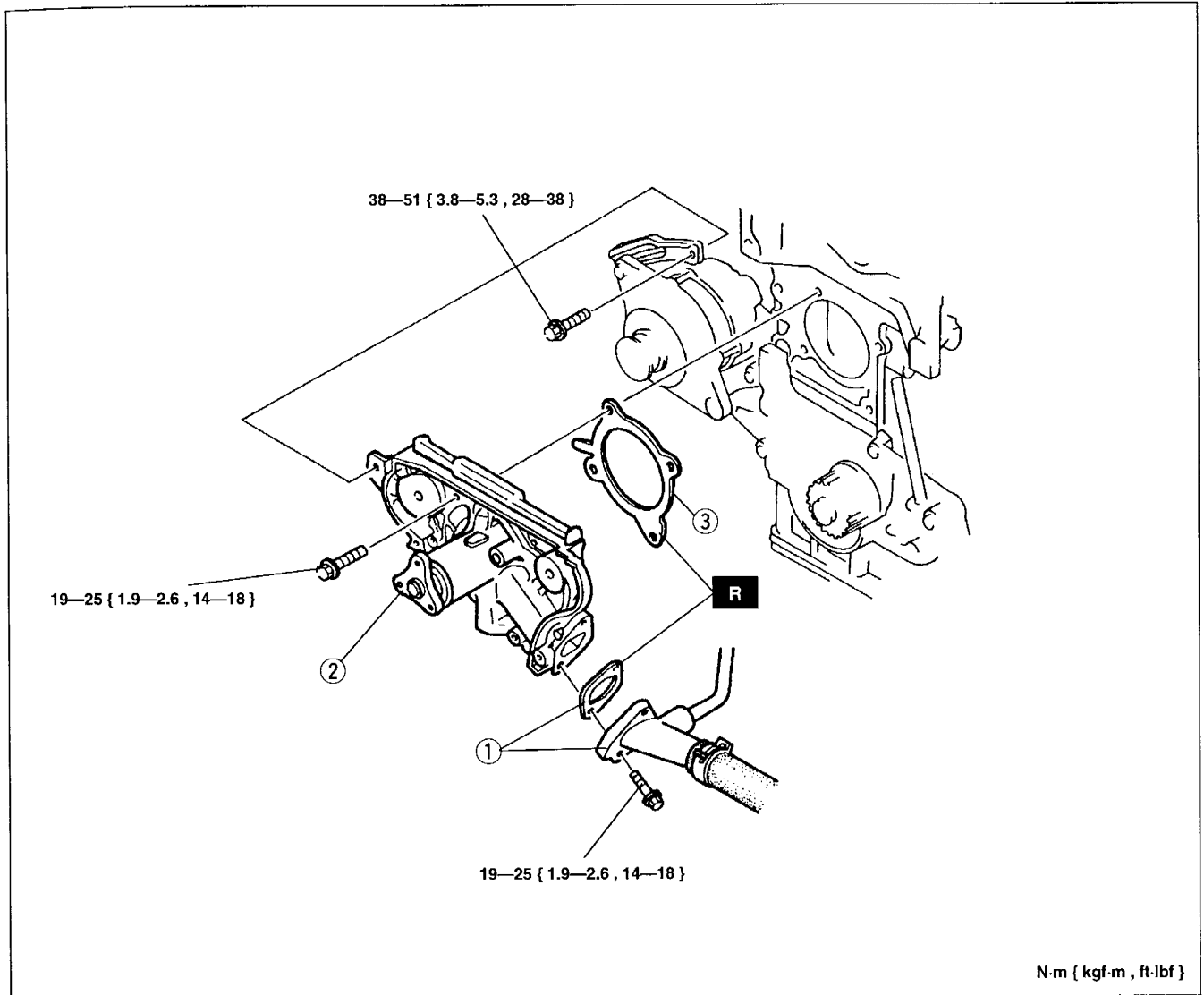

N·m { kgf·m , ft·lbf }

- | | |
|--|--|
| <ol style="list-style-type: none"> 1. Water pump inlet and gasket 2. Water pump assembly
If the water pump is damaged, replace it. Do not repair it. | <ol style="list-style-type: none"> 3. Water pump gasket |
|--|--|

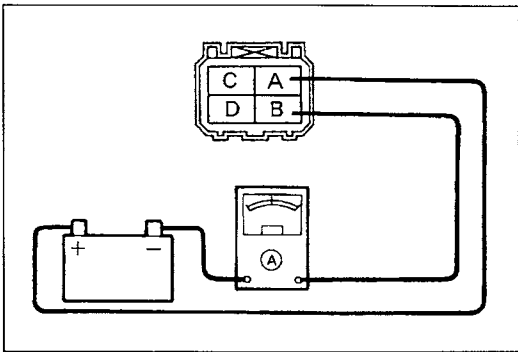

COOLING FAN MOTOR

INSPECTION

1. Verify that the battery is fully charged.
(Refer to section G.)
2. Disconnect the cooling fan motor connector.
3. Connect battery positive voltage and an ammeter to the cooling fan motor connector.
4. Verify that the cooling fan motor operates smoothly at the standard current draw.

**Current: 2.6—4.2 A (Z5, BP: MTX)
5.2—7.2 A (BP: ATX)**

5. If not as specified, replace the cooling fan motor.

REPLACEMENT

1. Disconnect the negative battery cable.
2. Remove the radiator. (Refer to page E-6.)
3. Remove in the order shown in the figure.
4. Install in the reverse order of removal.
5. Install the radiator. (Refer to page E-6.)
6. Connect the negative battery cable.
7. Warm up the engine to normal operating temperature.
8. Check the cooling fan motor for smooth operation.

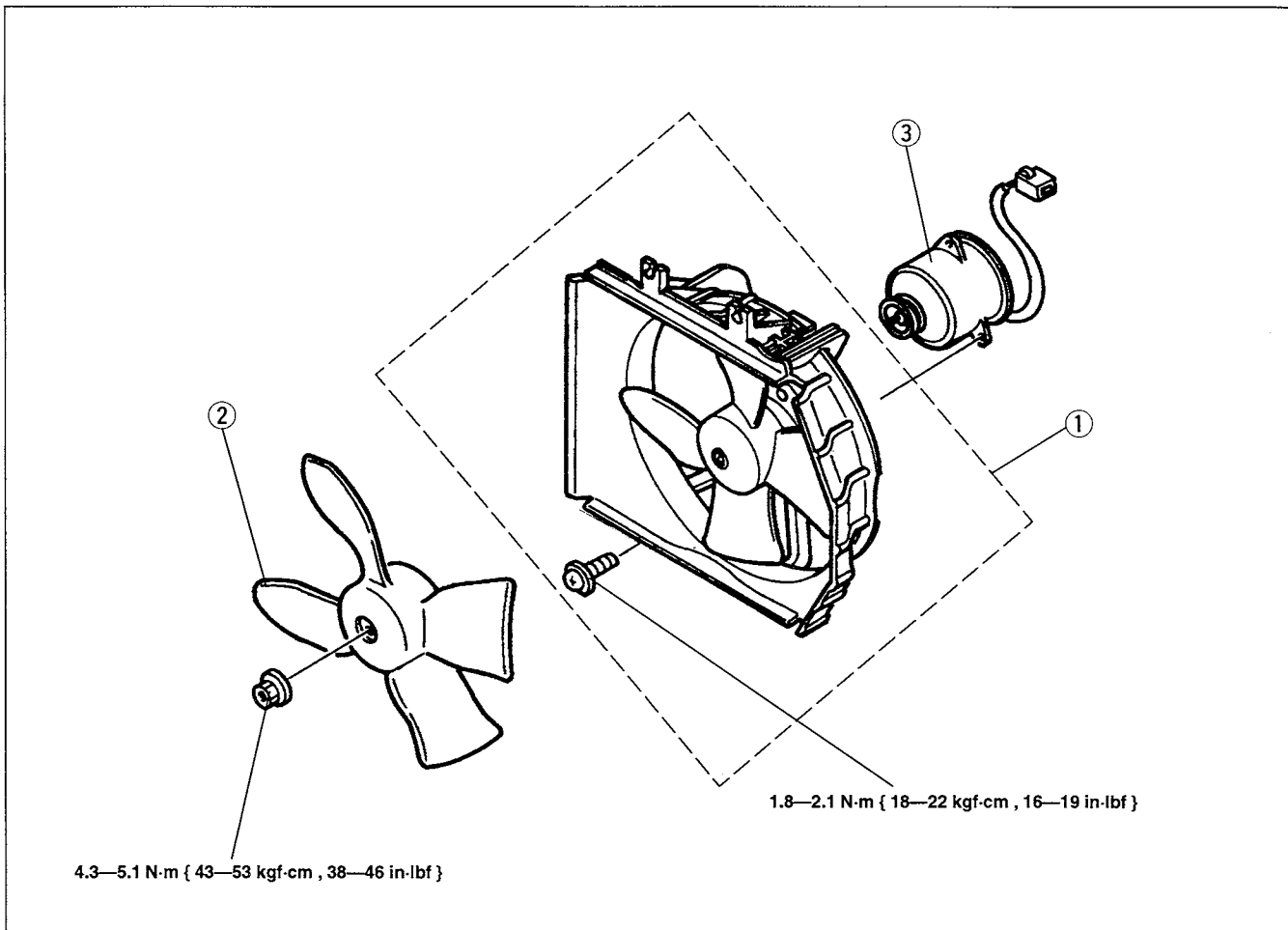

1. Cooling fan assembly
2. Cooling fan blade

3. Cooling fan motor

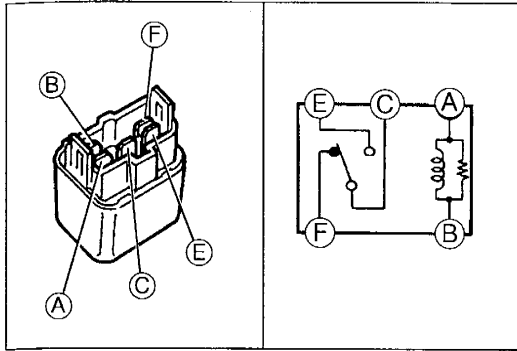

COOLING FAN RELAY

INSPECTION

1. Remove the cooling fan relay.
2. Apply battery positive voltage and check continuity between terminals of the cooling fan relay by using ohmmeter.

Specification

○—○: Continuity B+: Battery positive voltage

Step \ Terminal	A	B	C	E	F
1	○—○	○—○	○—○	○—○	○—○
2	B+	Ground	○—○	○—○	

3. If not as specified, replace the cooling fan relay.

Before beginning any service procedure, refer to section T1 of this manual for air bag system service warnings.



FUEL AND EMISSION CONTROL SYSTEMS (Z5)

ENGINE TUNE-UP	F1- 2	CONTROL SYSTEM	F1- 33
PREPARATION	F1- 2	PREPARATION	F1- 33
ADJUSTMENT	F1- 2	COMPONENT PARTS	F1- 34
INTAKE-AIR SYSTEM	F1- 5	POWERTRAIN CONTROL MODULE (PCM)	F1- 35
COMPONENT PARTS	F1- 5	MASS AIR FLOW SENSOR	F1- 43
AIR VALVE	F1- 8	CAMSHAFT POSITION SENSOR .	F1- 44
IDLE AIR CONTROL VALVE	F1- 8	CRANKSHAFT POSITION SENSOR	F1- 44
ACCELERATOR PEDAL	F1- 9	THROTTLE POSITION SENSOR .	F1- 45
ACCELERATOR CABLE	F1- 9	ENGINE COOLANT TEMPERATURE SENSOR	F1- 48
FUEL SYSTEM	F1-10	INTAKE AIR TEMPERATURE SENSOR	F1- 48
PREPARATION	F1-10	HEATED OXYGEN SENSOR	F1- 48
PRECAUTION	F1-10	EGR VALVE POSITION SENSOR .	F1- 49
COMPONENT PARTS	F1-11	EGR BOOST SENSOR	F1- 50
FUEL PUMP	F1-19	FUEL TANK PRESSURE SENSOR	F1- 51
FUEL INJECTOR	F1-20	CLUTCH SWITCH	F1- 52
PRESSURE REGULATOR	F1-21	NEUTRAL SWITCH	F1- 52
PRC SOLENOID VALVE	F1-22	POWER STEERING PRESSURE SWITCH	F1- 52
FUEL PUMP RELAY	F1-22	MAIN RELAY	F1- 53
EXHAUST SYSTEM	F1-23	ON-BOARD DIAGNOSTIC SYSTEM	F1- 54
PREPARATION	F1-23	PREPARATION	F1- 54
COMPONENT PARTS	F1-23	DIAGNOSTIC TROUBLE CODE NUMBER	F1- 54
EMISSION SYSTEM	F1-27	TROUBLESHOOTING	F1- 92
COMPONENT PARTS	F1-27	USING THIS SECTION	F1- 92
ROLLOVER VALVE	F1-29	DIAGNOSTIC INDEX	F1- 95
CHECK VALVE	F1-30	QUICK DIAGNOSIS CHART	F1- 96
TANK PRESSURE CONTROL VALVE (TPCV)	F1-30	SYMPTOM TROUBLESHOOTING	F1- 98
CHARCOAL CANISTER	F1-30	DIAGNOSTIC INSPECTION	F1-117
CANISTER DRAIN CUT VALVE (CDCV)	F1-31	SYSTEM INSPECTION	F1-119
PCV VALVE	F1-31		
PURGE SOLENOID VALVE	F1-31		
EGR VALVE	F1-31		
EGR SOLENOID VALVE	F1-32		
EGR BOOST SENSOR SOLENOID VALVE	F1-32		

ENGINE TUNE-UP

PREPARATION

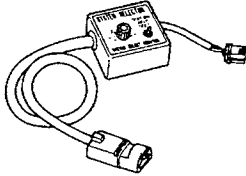
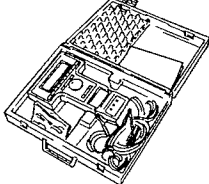
SST

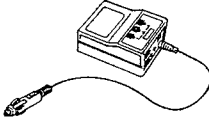
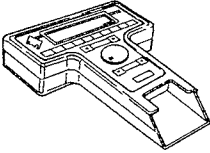
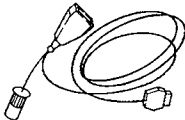
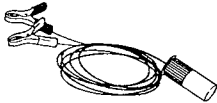
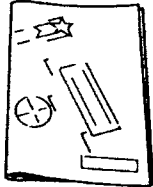
<p>49 B019 9A0 System Selector</p> 	<p>For inspection of ignition timing and idle speed</p>	<p>49 T088 0A0 NGS set</p> 	<p>For inspection of ignition timing and idle speed</p>
<p>49 T088 010B Program Card</p> 	<p>For inspection of ignition timing and idle speed</p>	<p>49 T088 002 Vehicle Interface Module (Part of 49 T088 0A0)</p> 	<p>For inspection of ignition timing and idle speed</p>
<p>49 T088 001 Control Unit (Part of 49 T088 0A0)</p> 	<p>For inspection of ignition timing and idle speed</p>	<p>49 T088 004 NGS OBDII Adapter (Part of 49 T088 0A0)</p> 	<p>For inspection of ignition timing and idle speed</p>
<p>49 T088 006 Battery Hookup Adapter (Part of 49 T088 0A0)</p> 	<p>For inspection of ignition timing and idle speed</p>	<p>49 T088 008A Instruction Manual</p> 	<p>For inspection of ignition timing and idle speed</p>

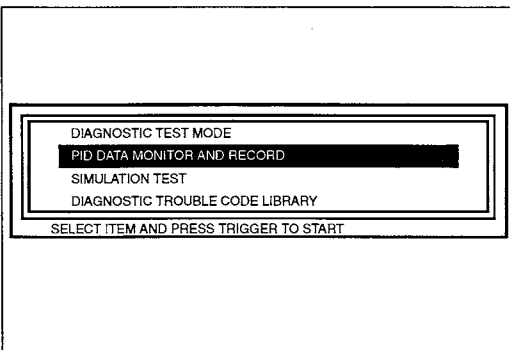

ADJUSTMENT

Preparation

1. Warm up the engine to normal operating temperature.
2. Shift the transaxle into Neutral (MTX) or P position (ATX).
3. Turn off all loads.
 - Headlight
 - Blower motor
 - Rear window defroster
 - Power steering
4. Wait until the cooling fan stops.
5. Connect the **SSTs** (NGS) to the data link connector-2 (Refer to page F1-37.) and select the PID/DATA MONITOR AND RECORD function.
6. Select the "RPM" on the NGS display.

Ignition Timing

1. Perform "Preparation". (Refer to above.)
2. Verify that the idle speed is within the specification.

**Specification: 650—750 (700 ± 50) rpm [MTX]
700—800 (750 ± 50) rpm [ATX]**

3. If not as specified, adjust the idle speed. (Refer to page F1-3.)

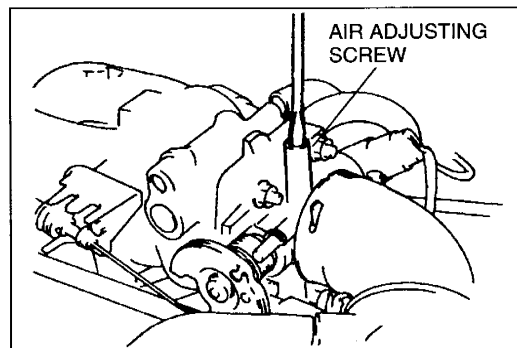
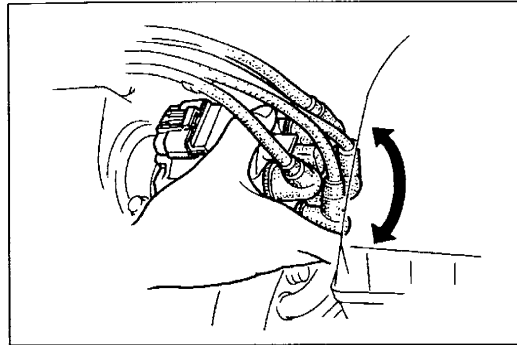
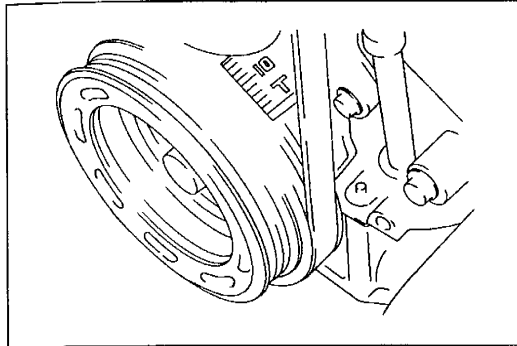
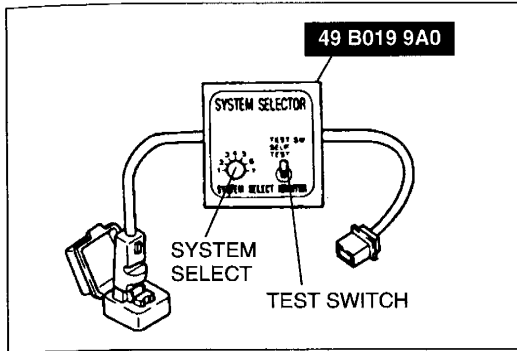

4. Connect the **SST** (System Selector) data link connector.
5. Set switch A to position 1.
6. Set the test switch to SELF TEST.
7. Connect a timing light to the high-tension lead of the No.1 cylinder.
8. Verify that the timing mark (yellow) is within the specification.

Specification: BTDC 9—11 ° (10 ± 1 °)

9. If not as specified, loosen the distributor lock bolts and turn the distributor to make the adjustment.
10. Tighten the distributor lock bolts to the specified torque.

Tightening torque:

19—25 N·m { 1.9—2.6 kgf·m , 14—18 ft·lbf }

11. Disconnect the **SST** (System Selector).
12. Verify that the timing mark (yellow) is within the specification.

Specification: BTDC 6—18 °

Idle Speed

1. Perform "Preparation". (Refer to page F1-2.)
2. Connect the **SST** (System Selector) to the data link connector.
3. Set switch A to position 1.
4. Set the test switch to SELF TEST.

Caution

- The throttle adjusting screw is set at the factory and must not be adjusted. Any adjustment will negatively effect the engine performance.

5. Adjust the idle speed by turning the air adjusting screw.

**Specification: 650—750 (700 ± 50) rpm [MTX]
700—800 (750 ± 50) rpm [ATX]**

6. Disconnect the **SST** (System Selector).

Idle Up Speed

1. Perform "Preparation". (Refer to page F1-2.)
2. Verify that the idle speed is within the specification.

**Specification: 650—750 (700 ± 50) rpm [MTX]
700—800 (750 ± 50) rpm [ATX]**

3. If not as specified, adjust the idle speed.
(Refer to page F1-3.)
4. Check the idle speed with the following load conditions.

Specification

Load condition	Idle speed (rpm)	
	MTX	ATX
Fan switch ON at 2nd or higher	650—750	700—800
Headlight switch ON		
Rear window defroster switch ON		
P/S ON	700—800	
A/C ON		

Note

- Excludes temporary idle speed drop just after the electrical loads are turned on.
5. If not as specified with all load condition, inspect the idle air control valve. (Refer to page F1-8.)
If not as specified with some load condition, check related input switches, harnesses and connectors.

Idle Mixture

1. Perform "Preparation". (Refer to page F1-2.)
2. Verify that the idle speed and ignition timing are within the specification.
3. Insert an exhaust gas analyzer to the tailpipe.
4. Verify that the CO and HC concentrations are within the regulation.
5. If not, inspect the following.
 - On-board diagnostic system (Refer to page F1-54.)
 - Heated oxygen sensor (Refer to page F1-48.)
 - System inspection
 - Intake manifold vacuum (Refer to page F1-119.)
 - Fuel line pressure (Refer to page F1-120.)
 - Ignition timing control (Refer to page F1-126.)
6. If the systems are normal, replace the three way catalytic converter and/or the warm up three way catalytic converter.

INTAKE-AIR SYSTEM

COMPONENT PARTS
Removal / Installation

Warning

- Fuel vapor is hazardous. It can very easily ignite, causing serious injury and damage. Always keep sparks and flames away from fuel.
- Fuel line spills and leaks are dangerous. Fuel can ignite and cause serious injuries or death and damage. Fuel can also irritate skin and eyes. To prevent this, always complete the "Fuel Line Safety Procedures" on page F1-10.

F1

1. Disconnect the negative battery cable.
2. Drain the coolant from the radiator. (Refer to section E.)
3. Remove in the order shown in the figure, referring to **Removal note**.
4. Install in the reverse order of removal, referring to **Installation note**.
5. Refill the radiator with the specified engine coolant. (Refer to section E.)

STEP 1

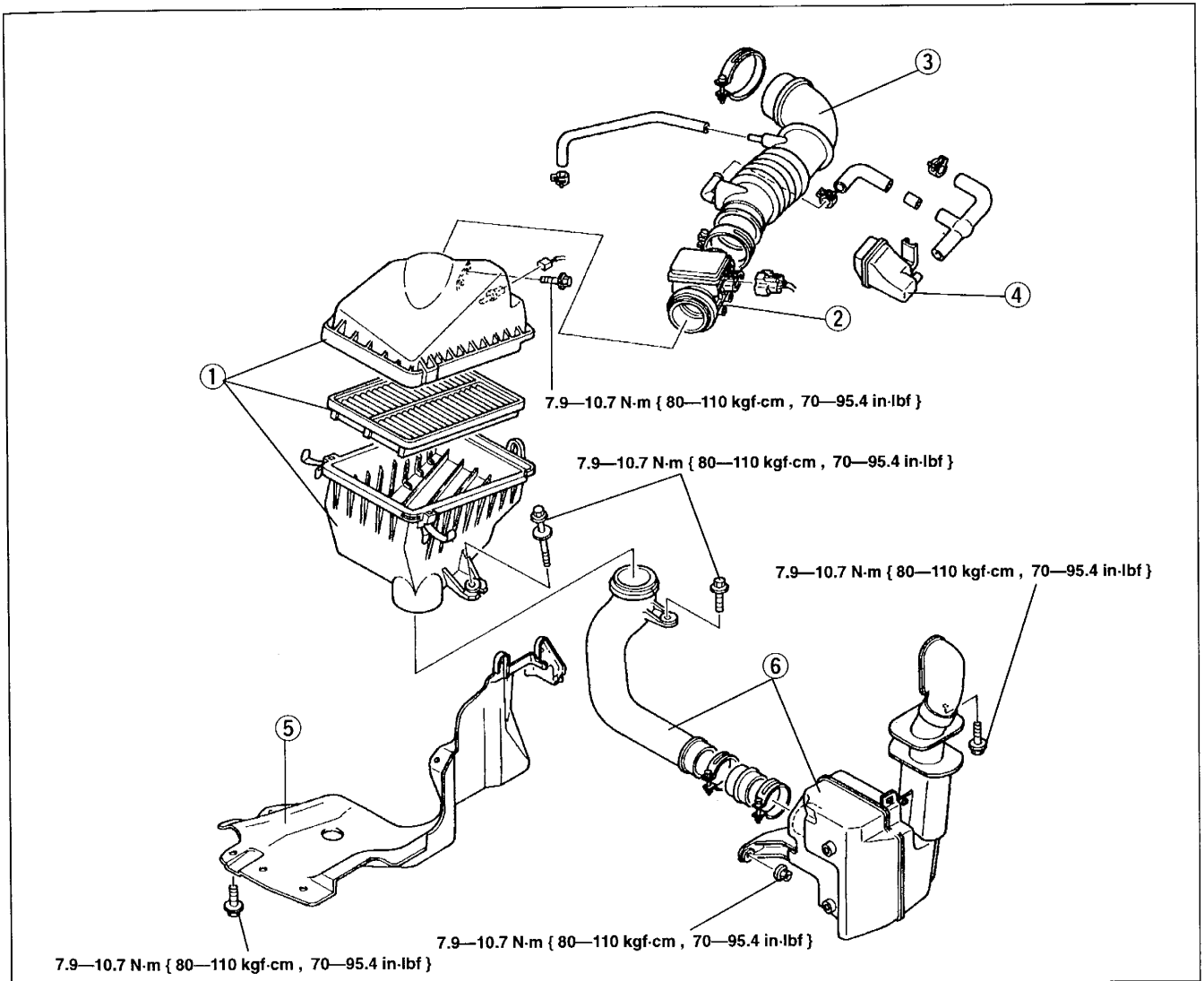

1. Air cleaner
2. Mass air flow sensor
3. Air intake hose
4. Resonance chamber

5. Splash shield
6. Fresh-air duct

Removal note page F1-6

Removal note**Fresh-air duct**

Before removing the fresh-air duct, remove the LH front mud guard mounting bolts, nut, and fasteners shown.

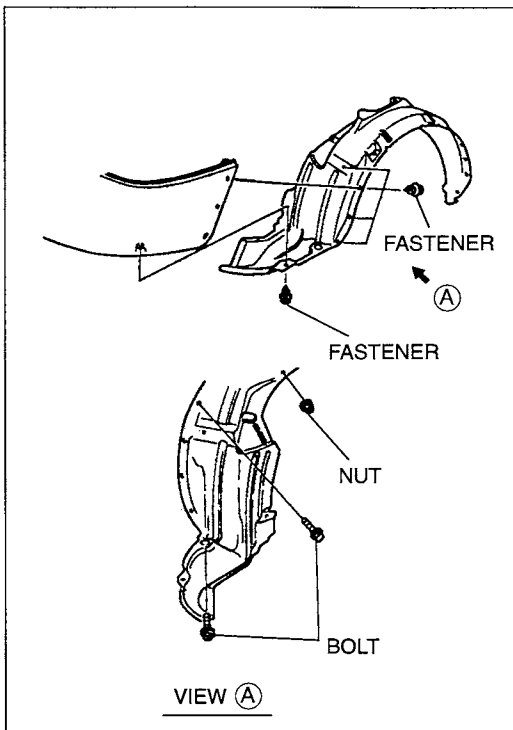

STEP 2

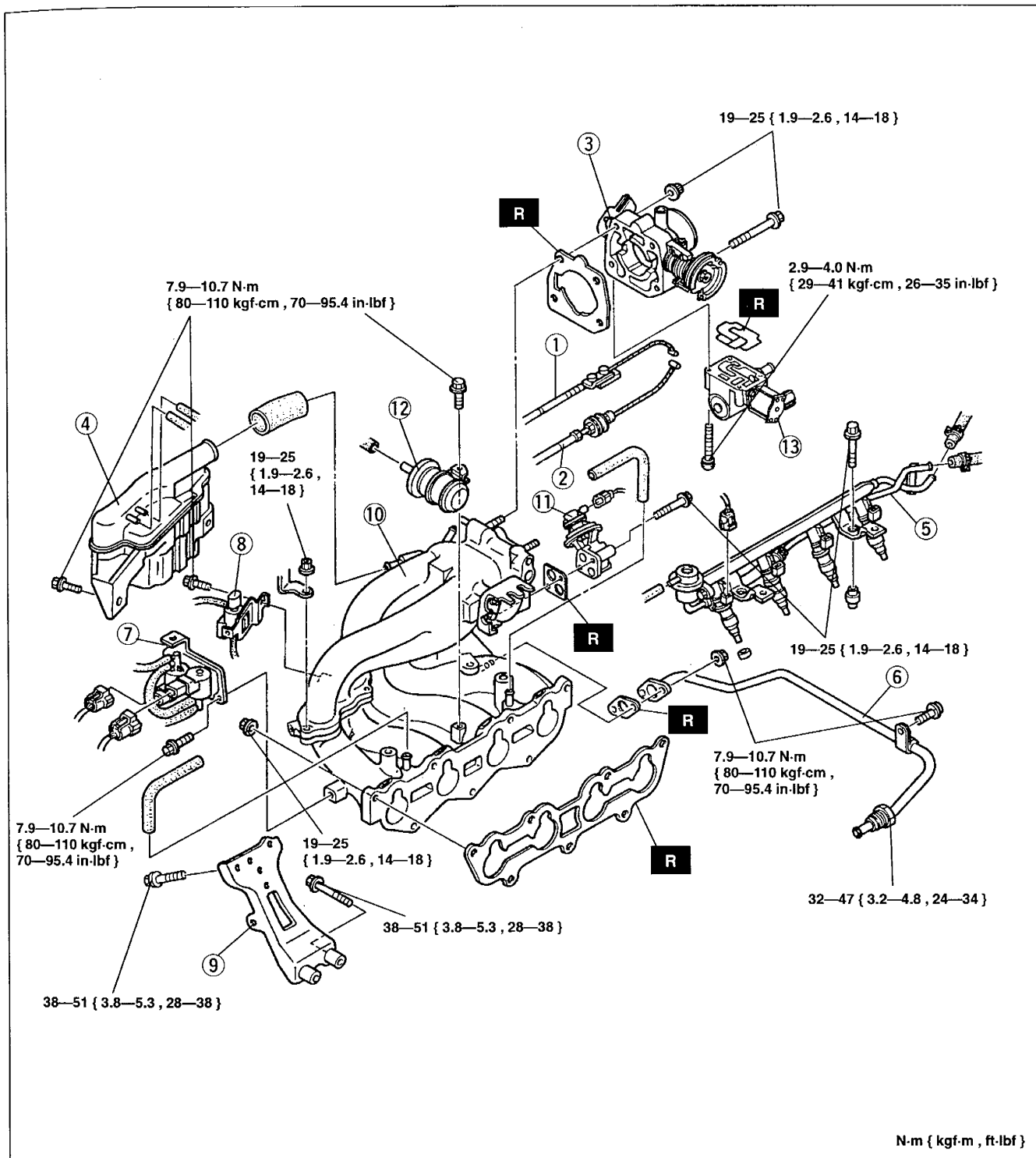

- | | |
|---|--|
| 1. Throttle cable (ATX)
Removal / Installation section K | 7. EGR solenoid valve stay |
| 2. Accelerator cable
Inspection / Adjustment page F1-9 | 8. PRC solenoid valve stay |
| 3. Throttle body | 9. Intake manifold stay |
| 4. Resonance chamber | 10. Intake manifold
Installation note page F1-8 |
| 5. Fuel distributor | 11. EGR valve |
| 6. EGR pipe | 12. Air filter |
| | 13. BAC valve |

N-m { kgf-m , ft-lbf }

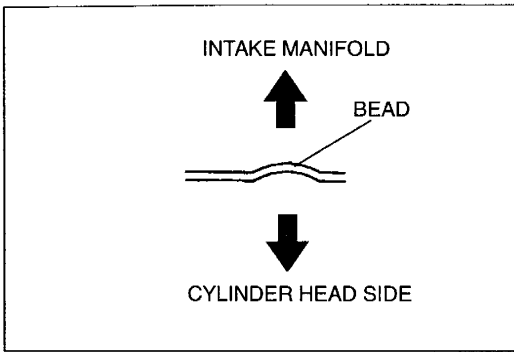

Installation note

Intake manifold

Face the bead of the gasket toward the intake manifold as shown, and install the intake manifold.

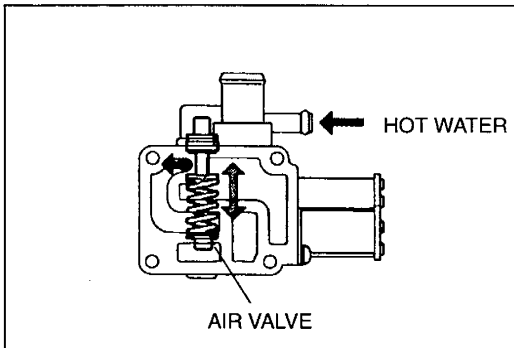

AIR VALVE

Inspection

1. Remove the BAC valve.
2. Circulate water in the BAC valve coolant passage to cool the air valve.
3. Circulate hot water in the BAC valve coolant passage and verify that the air valve operates.
4. If not, replace the BAC valve. (Refer to page F1-7.)

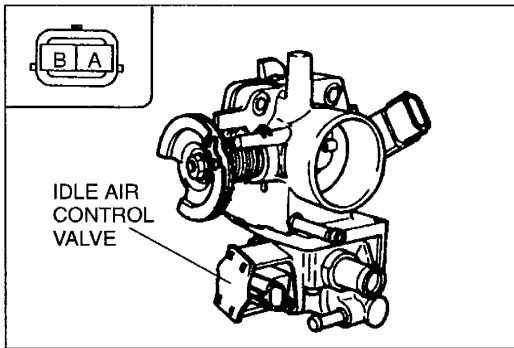

IDLE AIR CONTROL VALVE

Inspection

1. Verify that the ignition switch is OFF.
2. Disconnect the idle air control valve connector.
3. Measure the resistance of the idle air control valve by using an ohmmeter.

Specification: 7.7—9.3 Ω [23 °C { 73 °F }]

4. If not as specified, replace the BAC valve. (Refer to page F1-7.)

ACCELERATOR PEDAL

Removal / Installation

1. Remove in the order shown in the figure.
2. Install in the reverse order of removal.

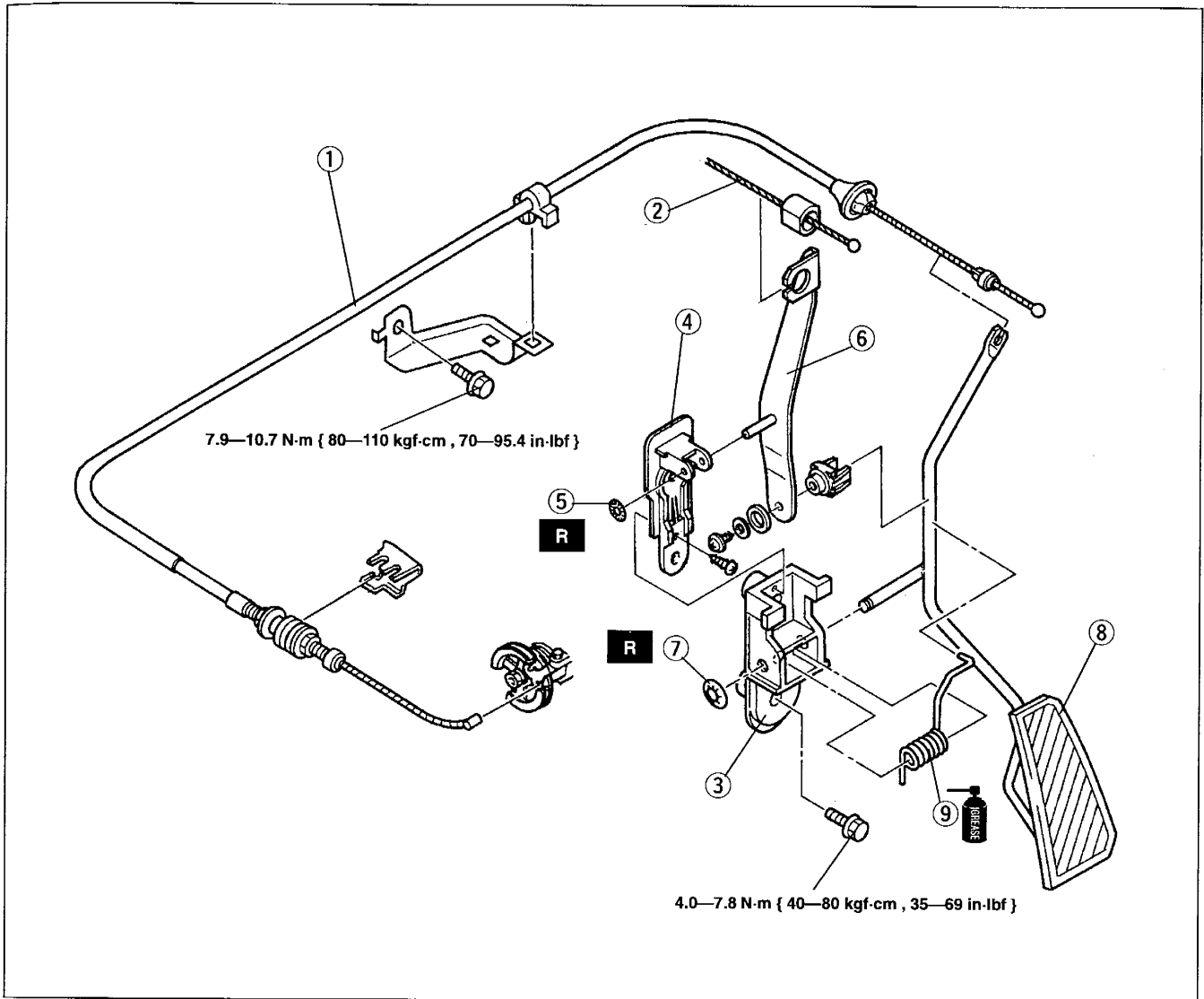

- | | |
|---|------------------------------------|
| 1. Accelerator cable
Inspection / Adjustment below | 5. Snap ring (with cruise control) |
| 2. Actuator cable (with cruise control) | 6. Bracket (with cruise control) |
| 3. Retainer | 7. Snap ring |
| 4. Retainer (with cruise control) | 8. Accelerator pedal |
| | 9. Return spring |

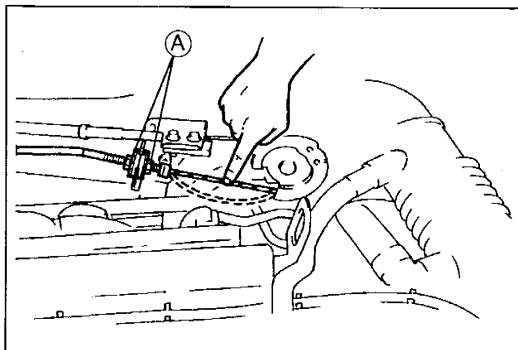

ACCELERATOR CABLE

Inspection / Adjustment

1. Verify that the throttle valve is at the closed throttle position.
2. Measure the free play of the accelerator cable.

Free play: 1—3 mm { 0.04—0.11 in }

3. If not as specified, adjust by turning locknut (A).

FUEL SYSTEM

PREPARATION
SST

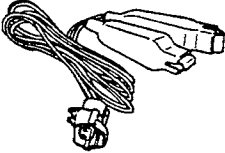
49 L018 901		For inspection of fuel injector
Injector checker		

PRECAUTION

Fuel Pressure Release and Servicing Fuel System

Warning

- Fuel vapor is hazardous. It can very easily ignite, causing serious injury and damage. Always keep sparks and flames away from fuel.

Fuel in the fuel system is under high pressure when the engine is not running.

Warning

- Fuel line spills and leaks are dangerous. Fuel can ignite and cause serious injuries or death and damage. Fuel can also irritate skin and eyes. To prevent this, always complete the following "Fuel Line Safety Procedures".

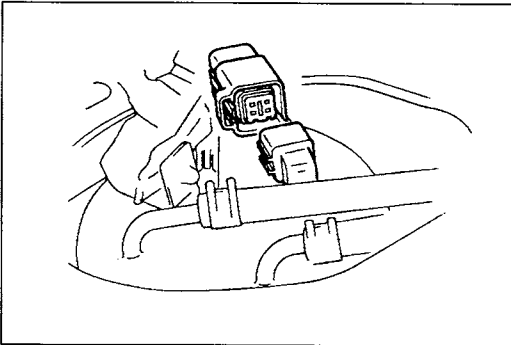

Fuel Line Safety Procedures

A. Release the fuel pressure before disconnecting a fuel line.

1. Remove the rear seat cushion.
(Refer to section S.)
2. Disconnect the fuel pump connector.
3. Start the engine.
4. After the engine stalls, turn the ignition switch to OFF.
5. Connect the fuel pump connector and install the rear seat cushion.

B. Avoid leakage

1. When disconnecting a fuel line hose, wrap a rag around it to protect against fuel leakage.
2. Plug the hose after removal.

C. Install hose clamps to secure the fuel pressure gauge.

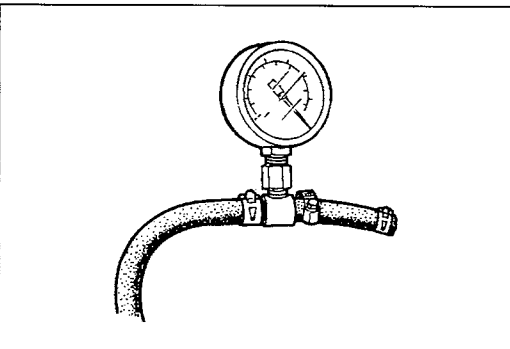

COMPONENT PARTS
Removal / Installation
Fuel tank

Warning

- Fuel vapor is hazardous. It can very easily ignite, causing serious injury and damage. Always keep sparks and flames away from fuel.
- Fuel line spills and leaks are dangerous. Fuel can ignite and cause serious injuries or death and damage. Fuel can also irritate skin and eyes. To prevent this, always complete the "Fuel Line Safety Procedures" on page F1-10.
- Repairing a fuel tank that has not been properly steam cleaned can be dangerous. Explosion or fire may cause death or serious injury. Always properly steam clean a fuel tank before repairing it.

1. Disconnect the negative battery cable.
2. Remove the drain plug and drain the fuel from the fuel tank.
3. Remove the rear seat cushion. (Refer to section S.)
4. Remove in the order shown in the figure.
5. Install in the reverse order of removal, referring to **Installation note**.
6. After installation, verify that the fuel tank is securely fixed.

STEP 1

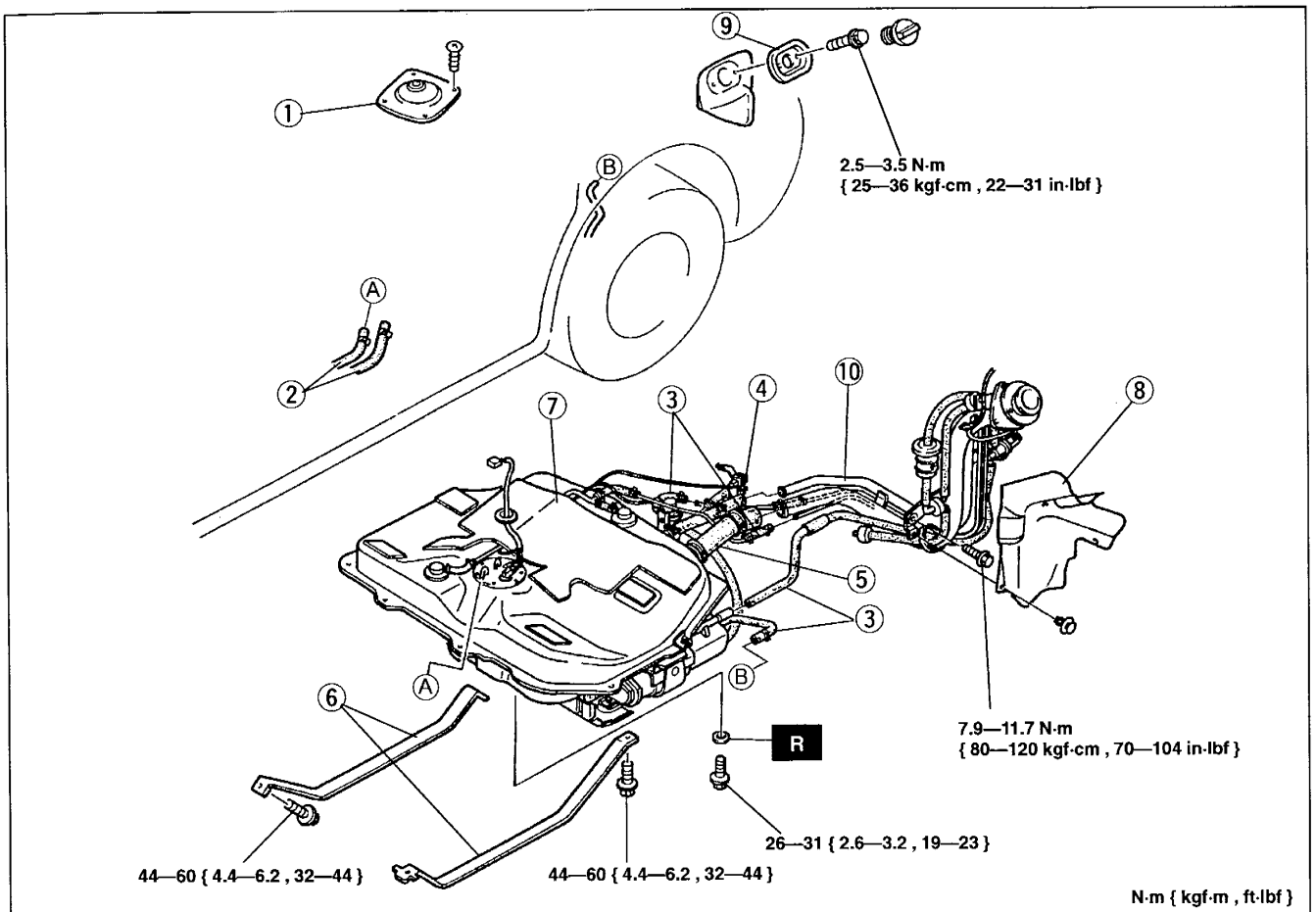

- | | |
|------------------------------------|------------------------------------|
| 1. Fuel pump cover | 5. Joint hose |
| 2. Fuel hoses | Installation note page F1-12 |
| Installation note page F1-12 | 6. Fuel tank straps |
| 3. Evaporative hoses | 7. Fuel tank |
| Installation note page F1-12 | 8. Protector |
| 4. Breather hose | 9. Dust cover |
| Installation note page F1-12 | 10. Fuel filler pipe |

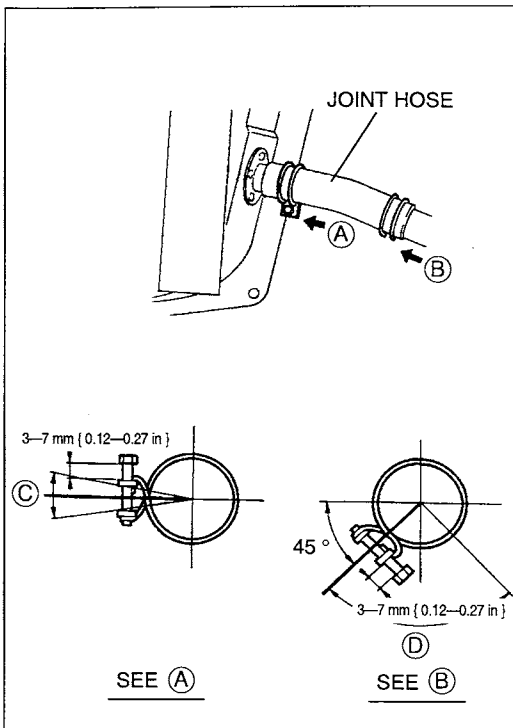

Installation note

Fuel hoses, evaporative hoses, breather hose

- Push the ends of the fuel hoses, evaporative hoses, and breather hose onto the respective fittings.

Specification: 25—30 mm { 0.99—1.18 in }

- Be sure the hoses are not bent or twisted.

Joint hose

- Push the ends of the joint hose onto the fitting.

Specification: 35—40 mm { 1.38—1.57 in }

- Install the clamps on the joint hose as shown.
- Position the tabs of each clamp within the allowable range.

Allowance

Ⓒ: 10° to both directions

Ⓓ: 90° to right

- Be sure the hose is not bent or twisted.

STEP 2

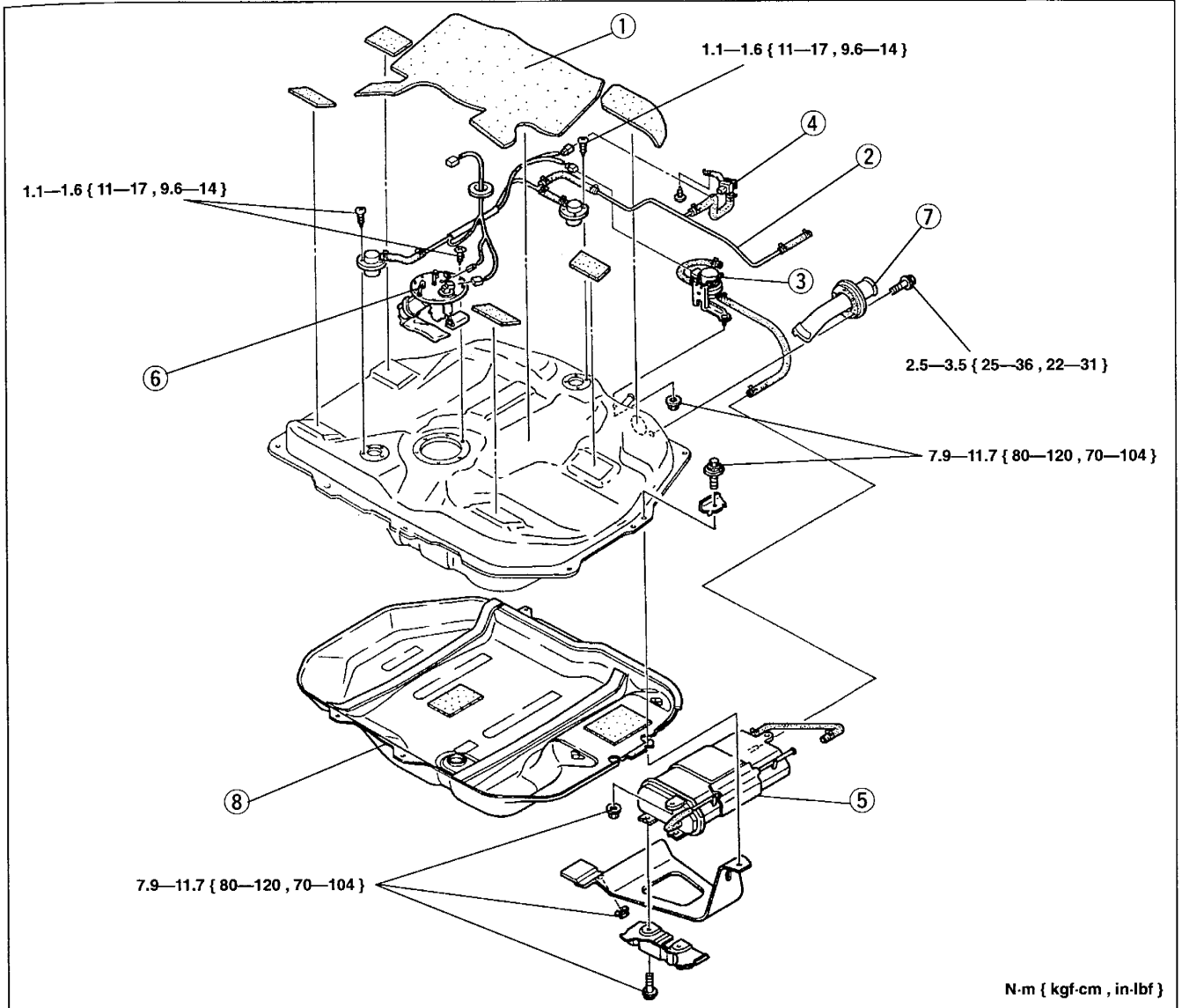

- | | | | |
|---------------------------------------|-----------------------------------|----------------------|------------------------------|
| 1. Pad | Installation note below | 5. Charcoal canister | |
| 2. Fuel pipe, rollover valve | Installation note below | 6. Fuel pump | |
| 3. Tank pressure control valve (TPCV) | | 7. Inlet pipe | Removal note below |
| 4. Fuel tank pressure sensor | | 8. Insulator | |

Removal note

Inlet pipe

- Remove the inlet pipe only when replacing the non-return valve.

Installation note

Fuel pipe, pad

- Stick pad (A) onto the fuel tank, over the harness (California only) and the fuel pipe as shown.
- Stick pad (B) and (C) onto the fuel tank as shown. (Upper surface of the fuel tank is projected for installation of pad (C).)
- Be sure the hoses are not bent or twisted.

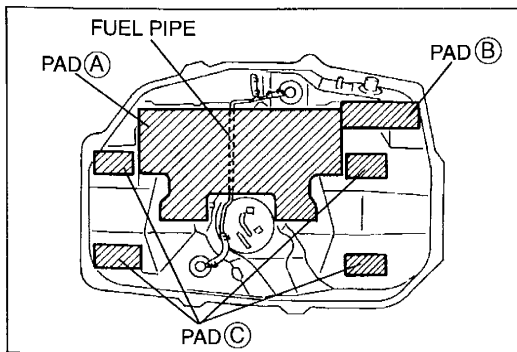

Fuel pump

Warning

- Fuel line spills and leaks are dangerous. Fuel can ignite and cause serious injuries or death and damage. Fuel can also irritate skin and eyes. To prevent this, always complete the “Fuel Line Safety Procedures” on page F1–10.

1. Disconnect the negative battery cable.
2. Remove the rear seat cushion. (Refer to section S.)
3. Remove in the order shown in the figure.
4. Install in the reverse order of removal, referring to **Installation note**.

STEP 1

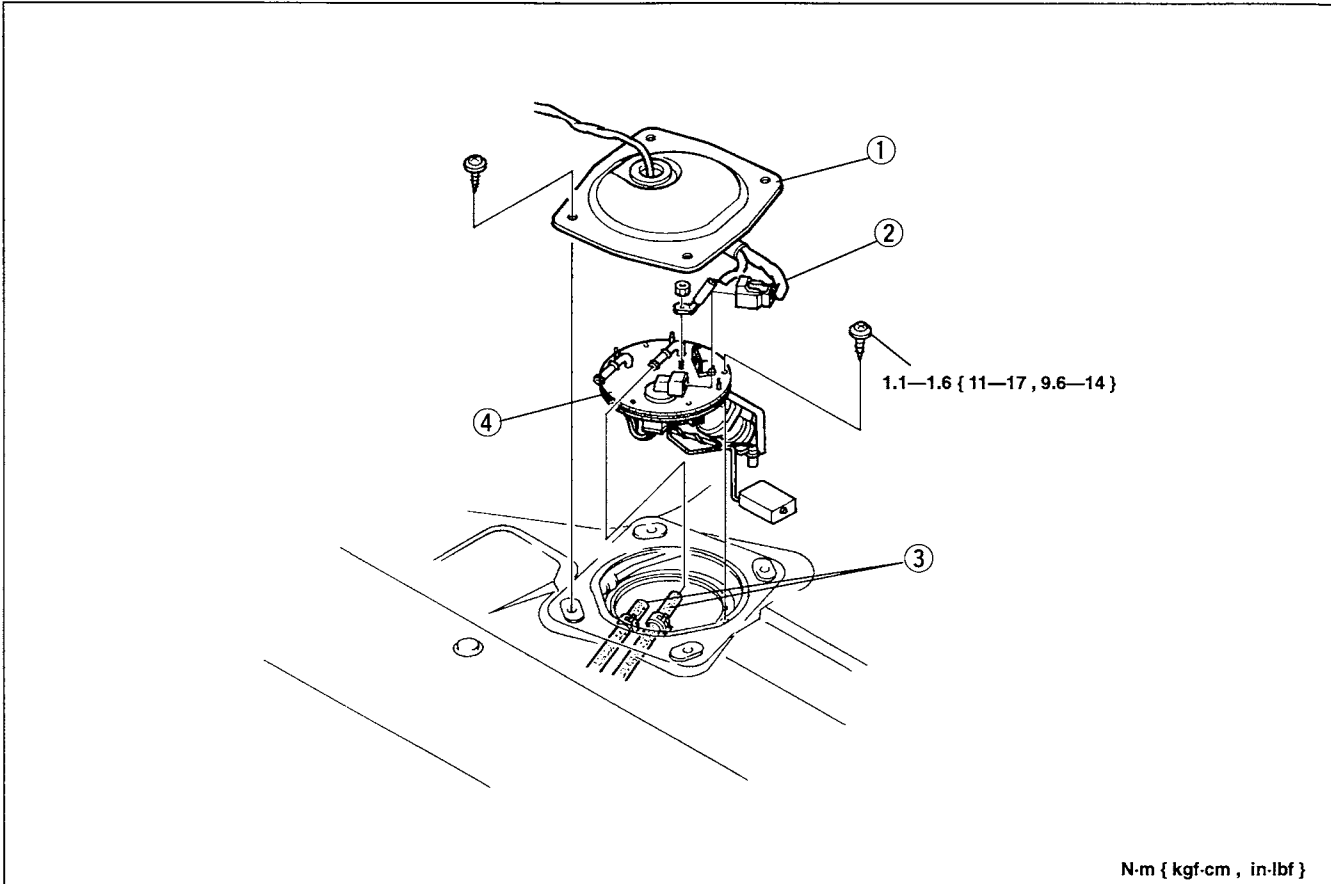

- | | |
|-----------------------------------|--------------|
| 1. Fuel pump cover | 4. Fuel pump |
| 2. Fuel pump connector | |
| 3. Fuel hoses | |
| Installation note below | |

Installation note

Fuel hoses

- Push the ends of the fuel hoses onto the respective fittings.

Specification: 25—30 mm { 0.99—1.18 in }

- Be sure the hoses are not bent or twisted.

STEP 2

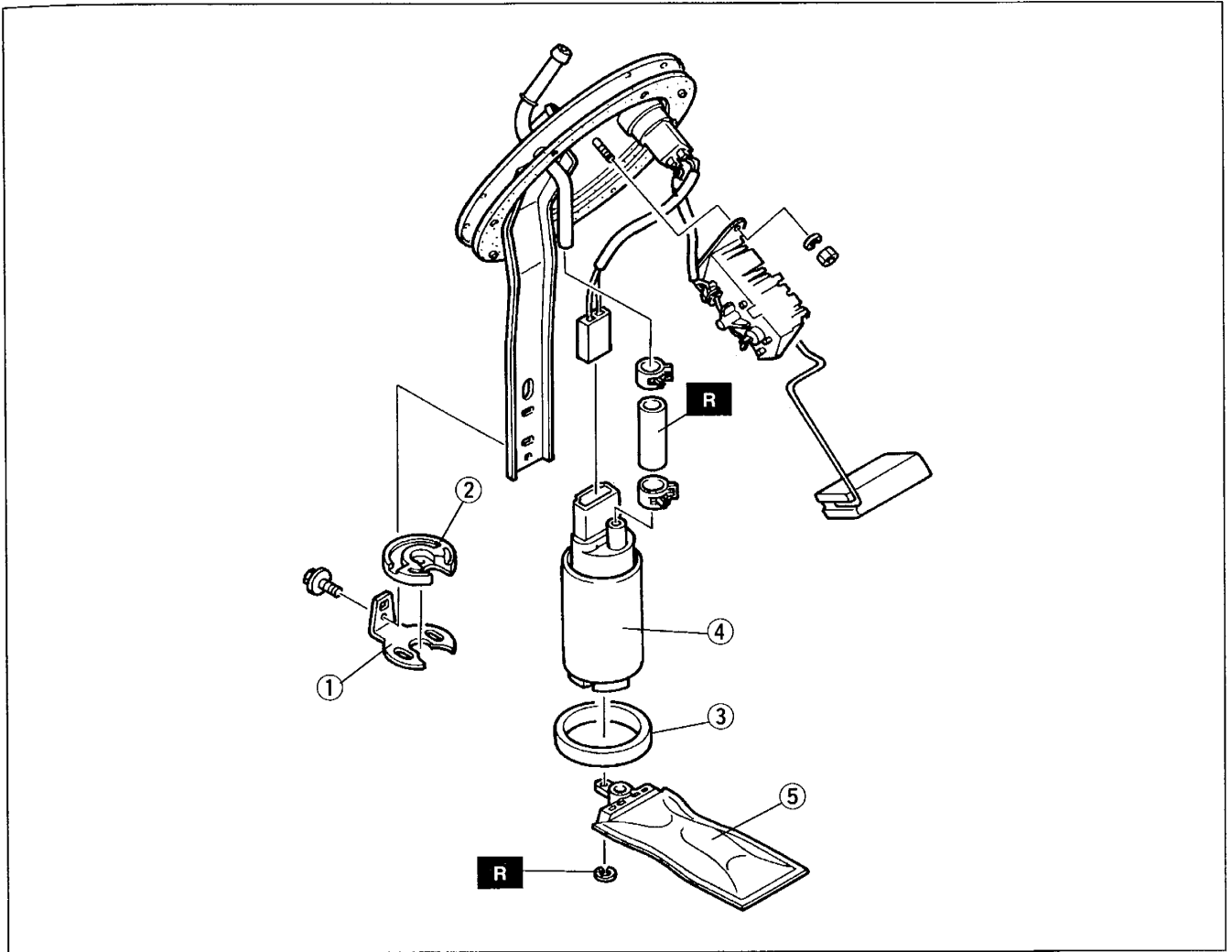

- 1. Bracket
- 2. Rubber mount
- 3. Band

- 4. Fuel pump
- 5. Fuel filter (low pressure side)

Fuel injector

Warning

- Fuel line spills and leaks are dangerous. Fuel can ignite and cause serious injuries or death and damage. Fuel can also irritate skin and eyes. To prevent this, always complete the "Fuel Line Safety Procedures" on page F1-10.

1. Disconnect the negative battery cable.
2. Remove in the order shown in the figure.
3. Install in the reverse order of removal, referring to **Installation note**.
4. Verify that the fuel injectors are properly installed by referring to **steps after installation**.

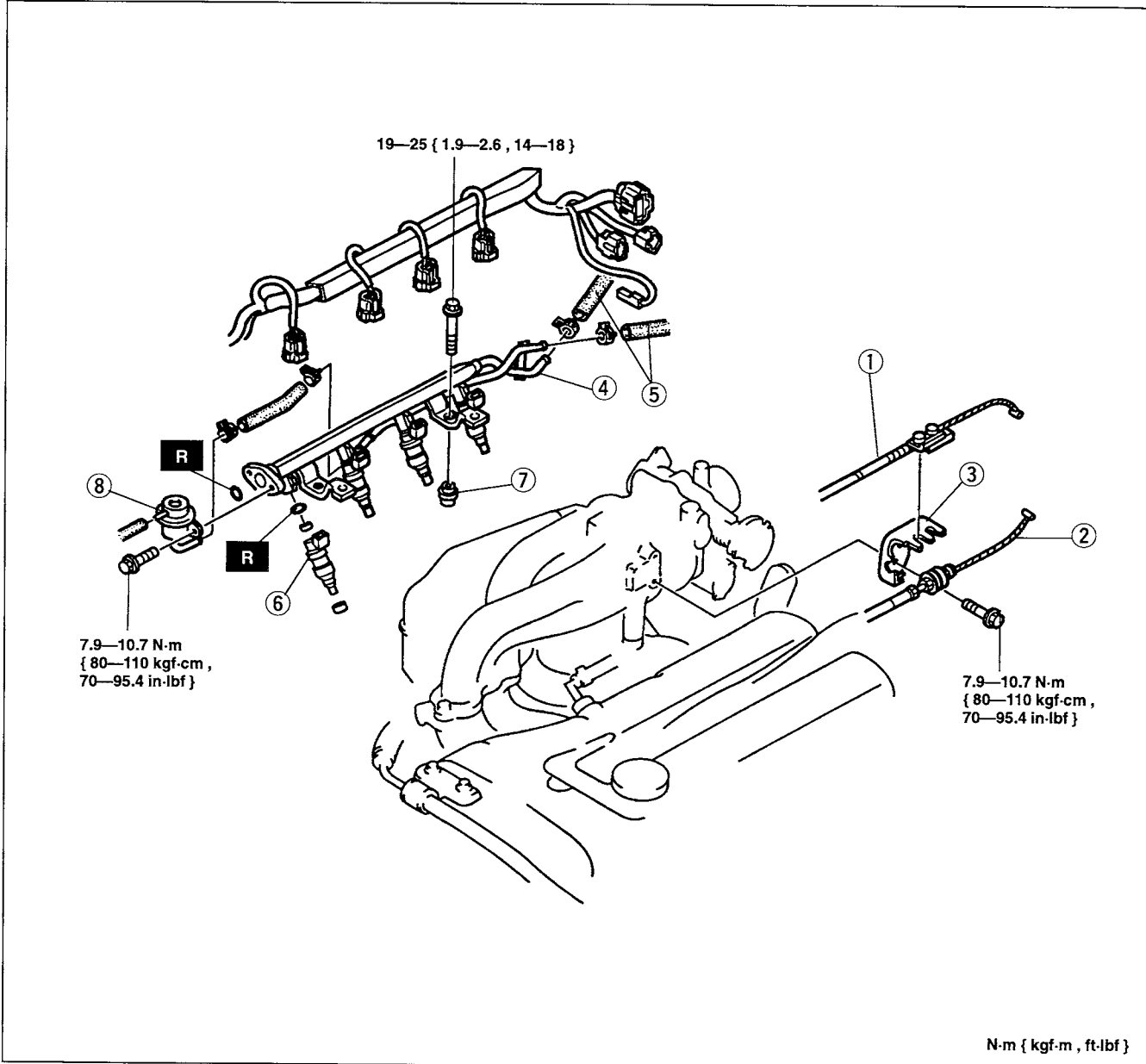

- | | |
|---|---|
| 1. Throttle cable
Removal / Installation section K | 5. Fuel hoses
Installation note page F1-17 |
| 2. Accelerator cable
Inspection / Adjustment page F1-9 | 6. Fuel injector
Installation note page F1-17 |
| 3. Throttle cable stay | 7. Insulator |
| 4. Fuel distributor | 8. Pressure regulator
Installation note page F1-17 |

Installation note**Fuel injector, pressure regulator**

- Apply a small amount of clean engine oil to the new O-rings, and install them.

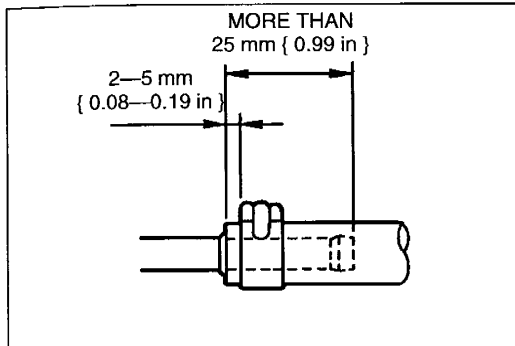
**Fuel hoses**

- Push the ends of the fuel hoses onto the respective fittings.

Specification: More than 25 mm { 0.99 in }

- Install the clip on the fuel hoses.

Specification:

2—5 mm { 0.08—0.19 in } from the end of hose

Steps after installation

1. Connect data link connector terminals F/P and GND with a jumper wire.
2. Turn the ignition switch to ON and check for fuel leaks from the fuel distributor assembly.
3. Turn off the ignition switch and disconnect the jumper wire.
4. If leaks are found, reinstall the fuel injector.

Fuel filter (high pressure side), PRC solenoid valve, fuel pump relay

Warning

- Fuel line spills and leaks are dangerous. Fuel can ignite and cause serious injuries or death and damage. Fuel can also irritate skin and eyes. To prevent this, always complete the "Fuel Line Safety Procedures" on page F1-10.

Note

- The fuel filter must be replaced at the intervals outlined in the maintenance schedule.

- Disconnect the negative battery cable.
- Remove in the order shown in the figure, referring to **Removal note**.
- Install in the reverse order of removal, referring to **Installation note**.

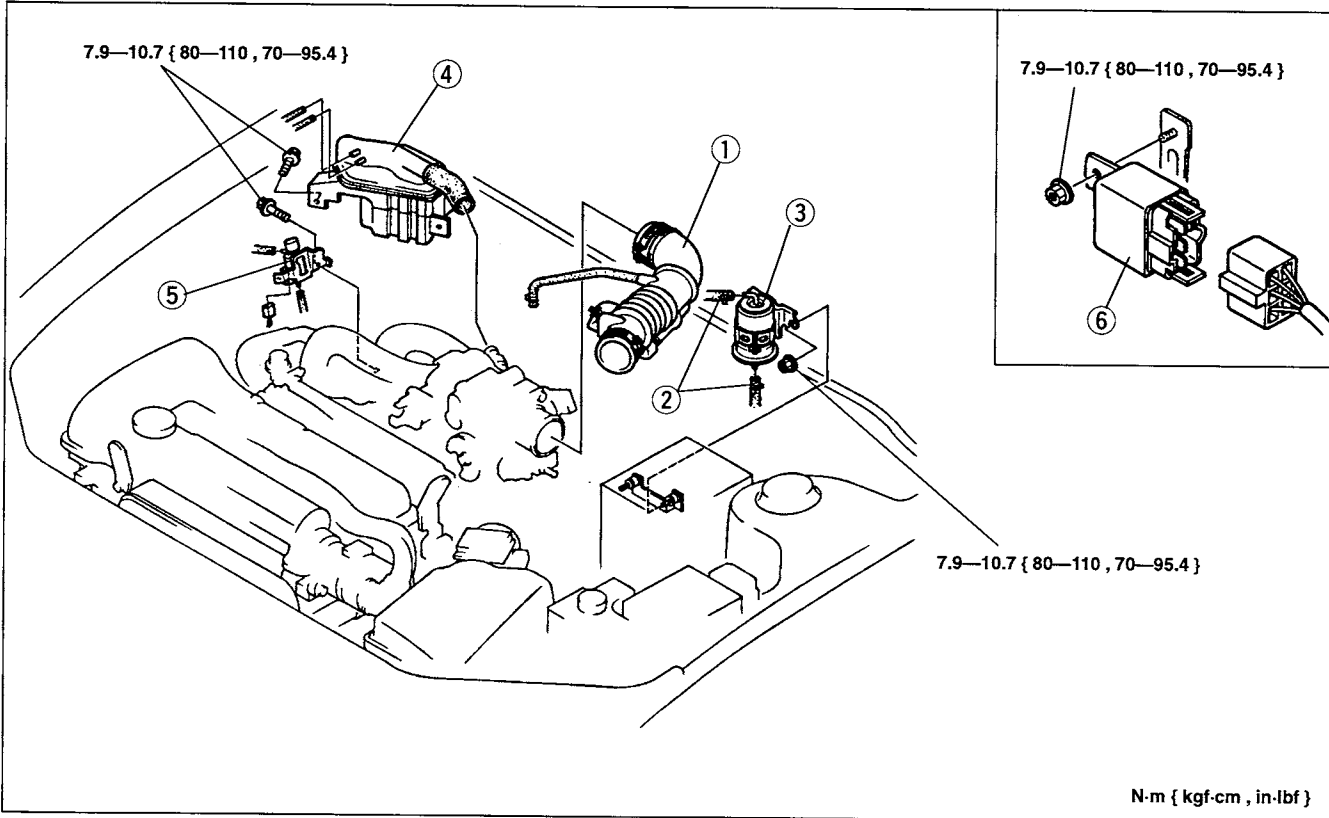

- | | |
|--|--|
| 1. Air intake hose | 4. Resonance chamber |
| 2. Fuel hoses
Installation note below | 5. PRC solenoid valve (Except California) |
| 3. Fuel filter (high pressure side) | 6. Fuel pump relay
Removal note below |

Removal note

Fuel pump relay

- Before removing the fuel pump relay, remove the rear console, front console and side wall. (Refer to section S.)

Installation note

Fuel hoses

- Push the ends of the fuel hoses onto the fittings until it stops.
- Install the clip on the fuel hoses.

Specification:

2—5 mm { 0.08—0.19 in } from the end of hose

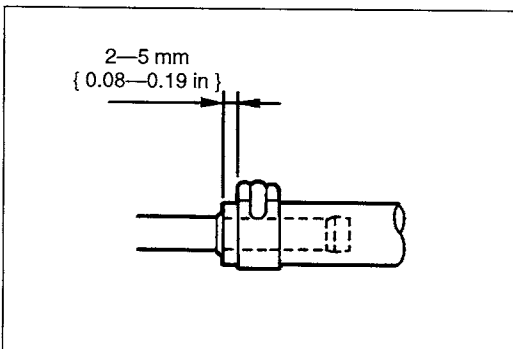

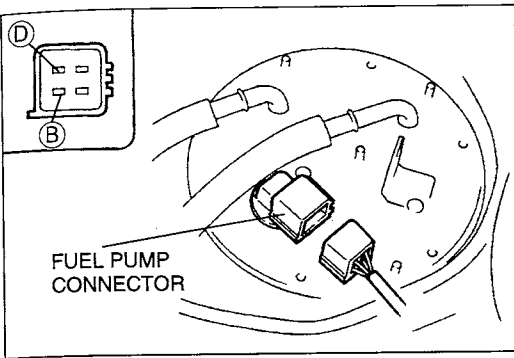

FUEL PUMP

Inspection

Fuel pump continuity

1. Remove the rear seat cushion. (Refer to section S.)
2. Remove the fuel pump cover.
3. Disconnect the fuel pump connector.
4. Check for continuity between fuel pump connector terminals B and D.
5. If there is no continuity, replace the fuel pump. (Refer to page F1-14.)

Fuel pump maximum pressure

Warning

- Fuel line spills and leaks are dangerous. Fuel can ignite and cause serious injuries or death and damage. Fuel can also irritate skin and eyes. To prevent this, always complete the "Fuel Line Safety Procedures" on page F1-10.

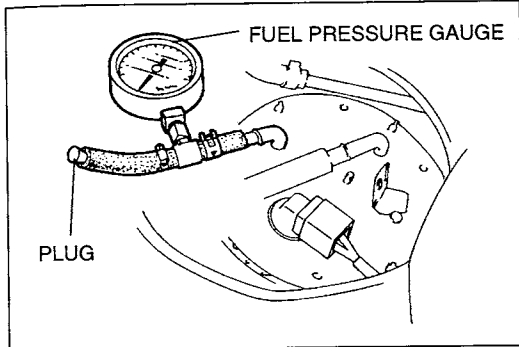

1. Disconnect the negative battery cable.
2. Connect a fuel pressure gauge to the fuel pump and plug the outlet of the gauge as shown.
3. Connect the negative battery cable.
4. Connect data link connector terminals F/P and GND by using a jumper wire.
5. Turn the ignition switch to ON. Measure the fuel pump pressure.

Pressure:

500—630 kPa { 5.0—6.5 kgf/cm² , 72—92 psi }

6. Turn off the ignition switch and disconnect the jumper wire.
7. If not as specified, replace the fuel pump. (Refer to page F1-14.)

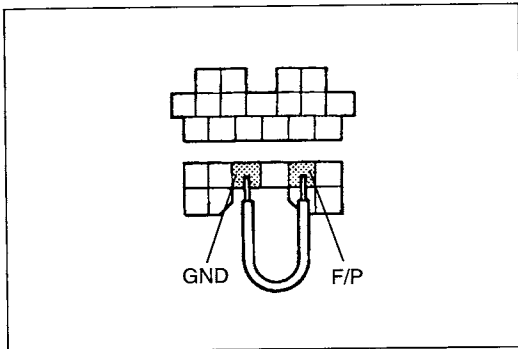

Fuel pump fuel hold pressure

Warning

- Fuel line spills and leaks are dangerous. Fuel can ignite and cause serious injuries or death and damage. Fuel can also irritate skin and eyes. To prevent this, always complete the "Fuel Line Safety Procedures" on page F1-10.

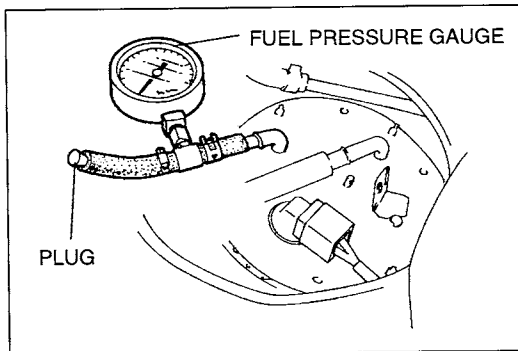

1. Disconnect the negative battery cable.
2. Connect a fuel pressure gauge to the fuel pump and plug the outlet of the gauge as shown.
3. Connect the negative battery cable.

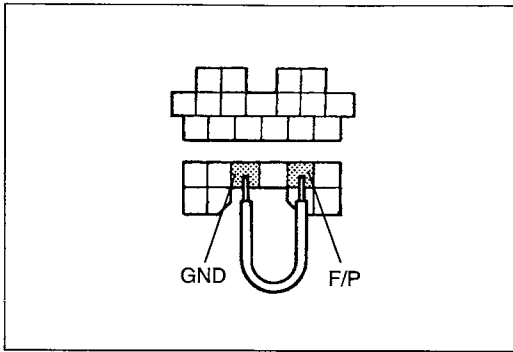

4. Connect data link connector terminals F/P and GND by using a jumper wire.
5. Turn the ignition switch to ON for approx. 10 sec. to operate the fuel pump.
6. Turn off the ignition switch. Wait for 5 min., and observe the fuel pressure.

Pressure: More than 150 kPa { 1.5 kgf/cm² , 21 psi }

7. Disconnect the jumper wire.
8. If not as specified, replace the fuel pump.
(Refer to page F1-14.)

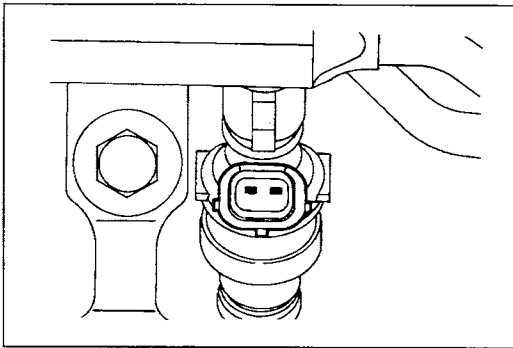

FUEL INJECTOR

Inspection Resistance

1. Disconnect the fuel injector connectors.
2. Measure the resistance of the fuel injectors.

Resistance: Approx. 13.8 Ω [20 °C { 68 °F }]

3. If not as specified, replace the fuel injector.
(Refer to page F1-16.)

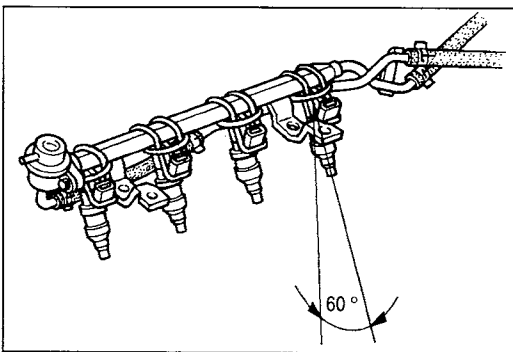

Fuel leakage test

1. Remove the fuel injectors together with the fuel distributor. (Refer to page F1-16.)
2. Fasten the fuel injectors firmly to the fuel distributor with wire and connect the fuel hoses.
3. Tilt the fuel injectors approx. 60 degrees from upright position as shown.
4. Connect data link connector terminals F/P and GND by using a jumper wire.
5. Turn the ignition switch to ON and check for fuel leaks from the fuel injectors.

Fuel leakage: Less than 1 drop/2 minutes

6. Turn off the ignition switch and disconnect the jumper wire.
7. If not as specified, remove the leaking fuel injector and reinstall the fuel injector, referring to **Installation note**.
8. Recheck the fuel leakage. If not as specified, replace the fuel injector. (Refer to page F1-16.)

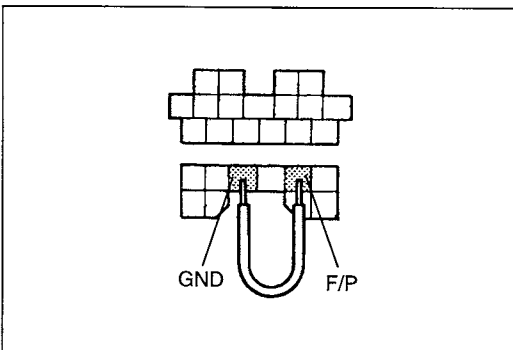

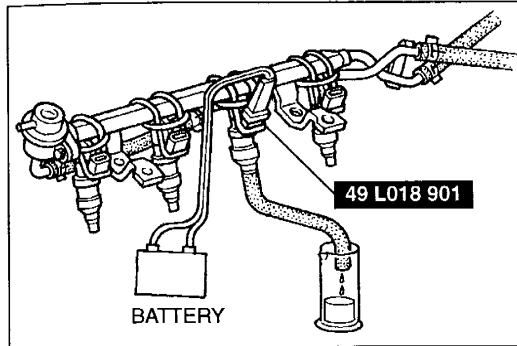
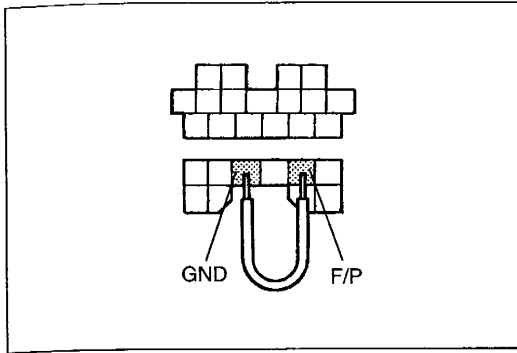

Volume test

1. Remove the fuel injectors together with the fuel distributor. (Refer to page F1-16.)
2. Fasten the fuel injectors firmly to the fuel distributor with wire and connect the fuel hoses.
3. Connect data link connector terminals F/P and GND by using a jumper wire.
4. Turn the ignition switch to ON.
5. Connect the **SST** as shown in the figure.
6. Measure the injection volume of each fuel injector by using a graduated container.

Injection volume:

39—50 ml { 39—50 cc , 1.4—1.6 fl oz }/15 sec.

7. Turn off the ignition switch and disconnect the jumper wire.
8. If not as specified, replace the fuel injector. (Refer to page F1-16.)

PRESSURE REGULATOR

Inspection

Warning

- Fuel line spills and leaks are dangerous. Fuel can ignite and cause serious injuries or death and damage. Fuel can also irritate skin and eyes. To prevent this, always complete the “Fuel Line Safety Procedures” on page F1-10.

1. Disconnect the negative battery cable.
2. Remove the air intake hose. (Refer to page F1-5.)
3. Connect a fuel pressure gauge between the fuel filter (high pressure side) and the main fuel hose.
4. Install the air intake hose.
5. Connect the negative battery cable.
6. Start the engine and let it idle.
7. Carry out the intake manifold vacuum inspection. (Refer to page F1-119.)
8. Measure the fuel line pressure.

Pressure:

200—240 kPa { 2.0—2.4 kgf/cm² , 29—34 psi }

9. If not as specified, carry out the fuel line pressure inspection (Refer to page F1-120.) and inspect the PRC solenoid valve. (Refer to page F1-22.)
10. Disconnect the vacuum hose from the pressure regulator.
11. Measure the fuel line pressure.

Pressure:

280—310 kPa { 2.8—3.2 kgf/cm² , 40—45 psi }

12. If not as specified, replace the pressure regulator. (Refer to page F1-16.)

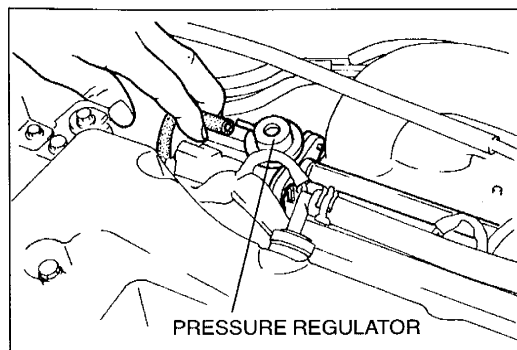
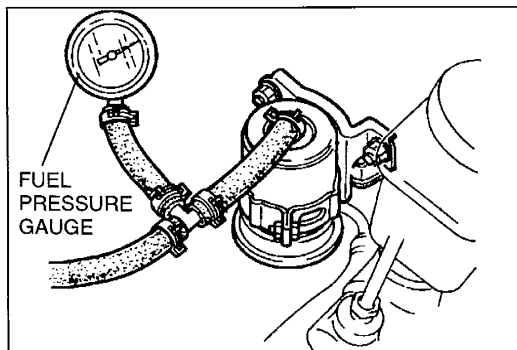

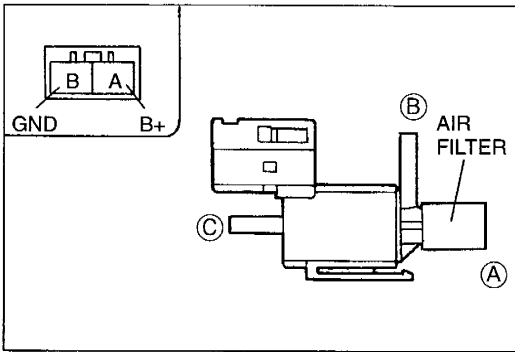

PRC SOLENOID VALVE (Except California)

Inspection

1. Remove the PRC solenoid valve. (Refer to page F1-18.)
2. Check for air flow between ports of the solenoid valve.

○—○: Continuity ○=○: Air flow B+: Battery positive voltage

Step	Terminal		Port		
	A	B	A	B	C
1	○—○	○—○		○=○	○=○
2	B+	Ground	○=○	○=○	

3. If not as specified, replace the PRC solenoid valve.

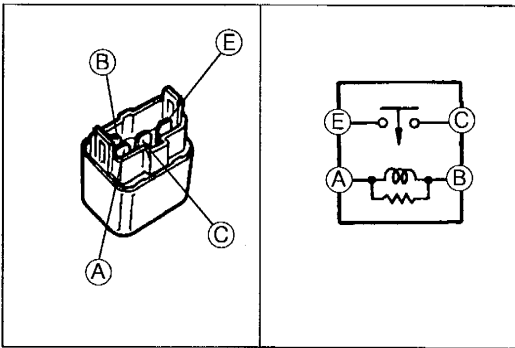

FUEL PUMP RELAY

Inspection

1. Remove the fuel pump relay. (Refer to page F1-18.)
2. Check for continuity between terminals of the relay by using an ohmmeter.

○—○: Continuity B+: Battery positive voltage

Step	Terminal	A	B	C	E
	1		○—○	○—○	
2		B+	Ground	○—○	○—○

3. If not as specified, replace the fuel pump relay.

EXHAUST SYSTEM**PREPARATION****SST**

49 T018 001

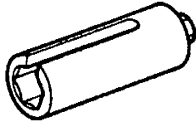
Wrench, O₂
sensorFor
replacement of
heated oxygen
sensor**COMPONENT PARTS****Inspection**

1. Start the engine and check for exhaust gas leakage from each exhaust system components.
2. If leakage is found, repair or replace as necessary.

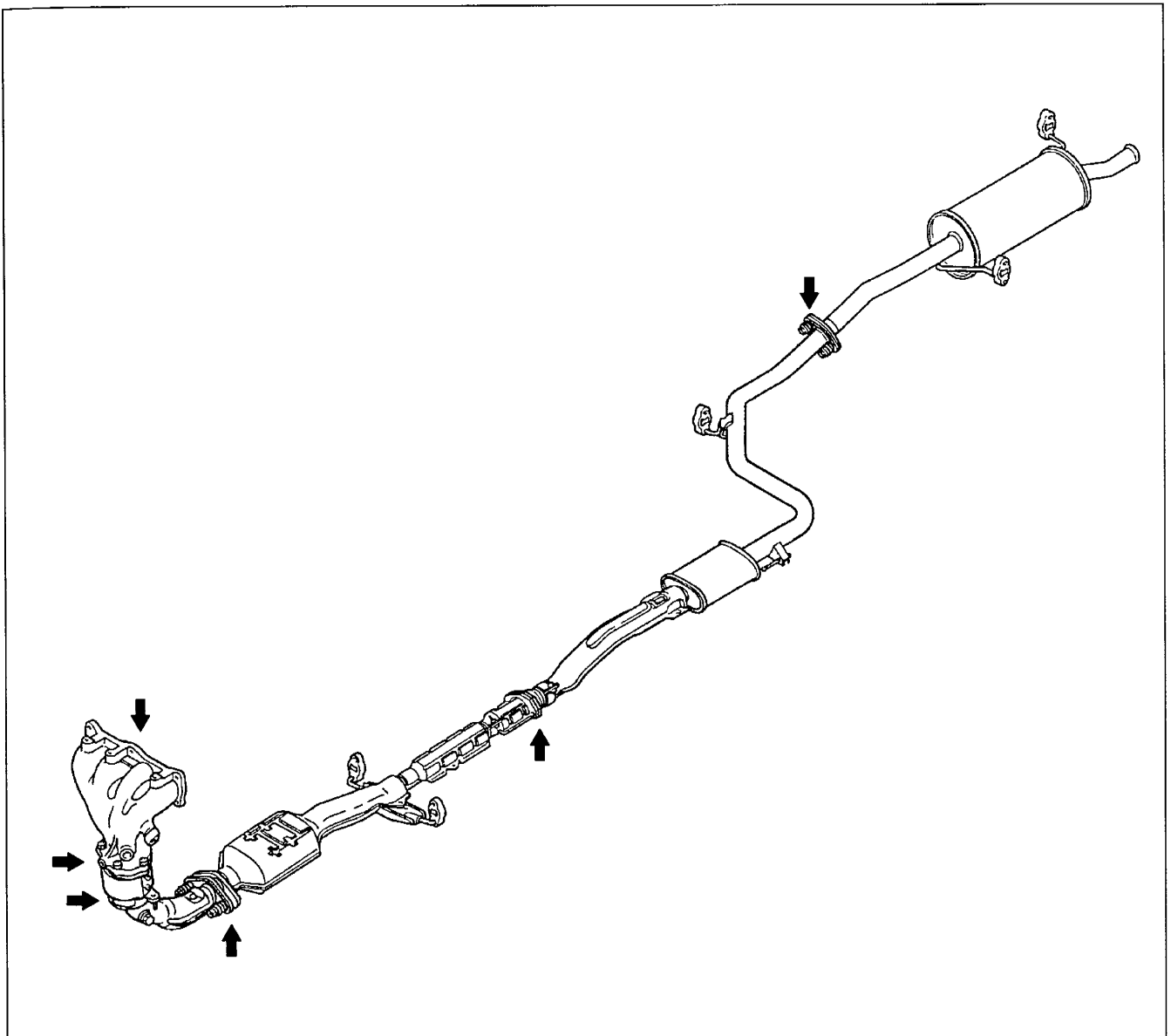

Removal / Installation

1. Disconnect the negative battery cable.
2. Remove in the order shown in the figure, referring to **Removal note**.
3. Install in the reverse order of removal, referring to **Installation note**.

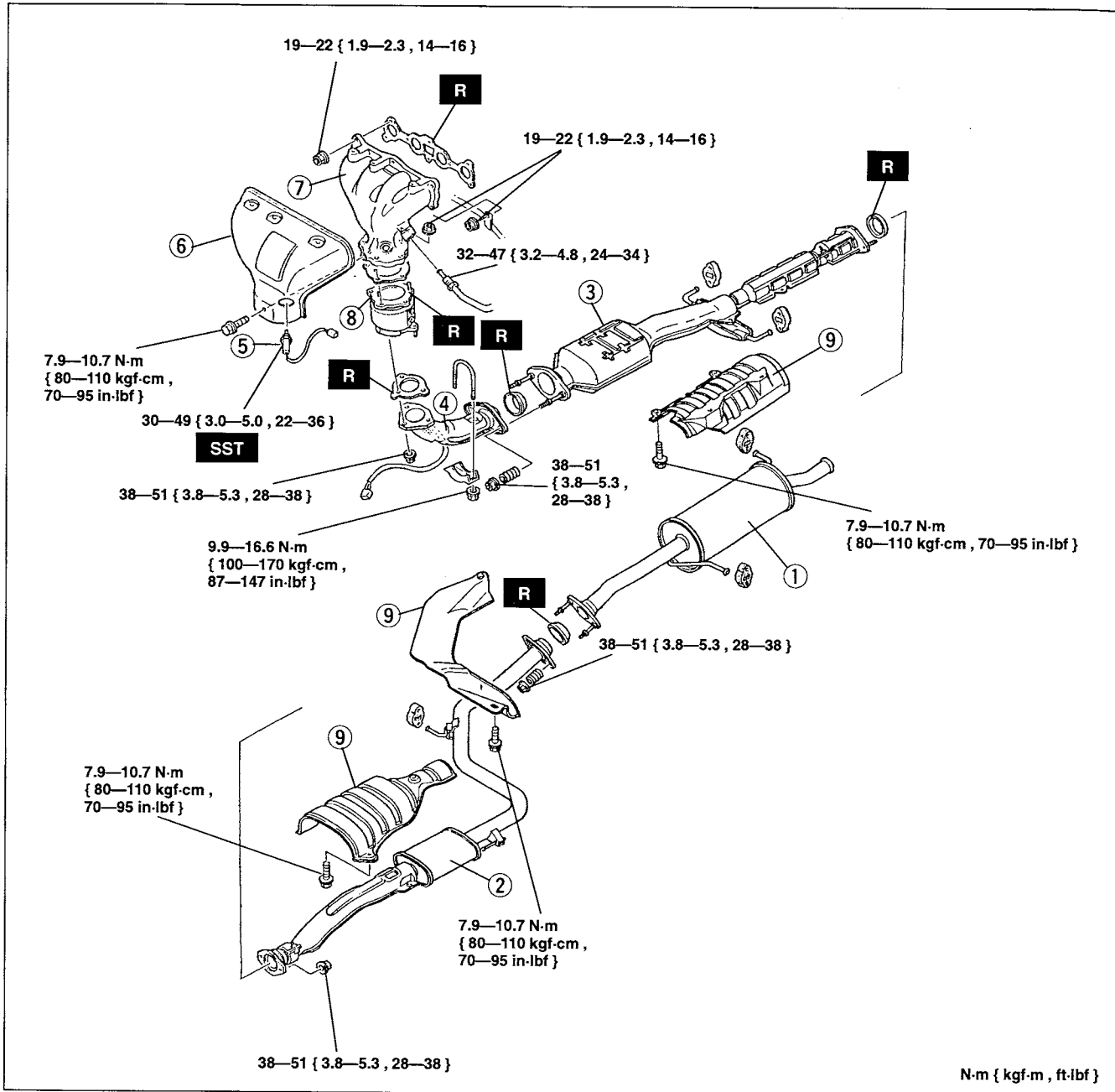

- | | |
|--|---|
| <ol style="list-style-type: none"> 1. Main silencer 2. Presilencer 3. Three way catalytic converter 4. Front pipe
Installation note page F1-25 5. Heated oxygen sensor 6. Exhaust manifold insulator
Removal note page F1-25 | <ol style="list-style-type: none"> 7. Exhaust manifold
Removal note page F1-25
Installation note page F1-26 8. Warm up three way catalytic converter
Installation note page F1-26 9. Insulator |
|--|---|

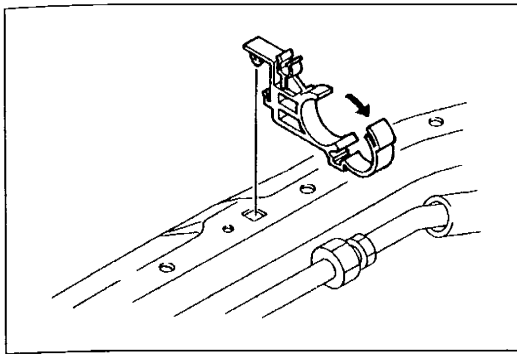

Removal note

Exhaust manifold insulator

Remove the A/C pipe stay and remove the exhaust manifold insulator from over the vehicle.

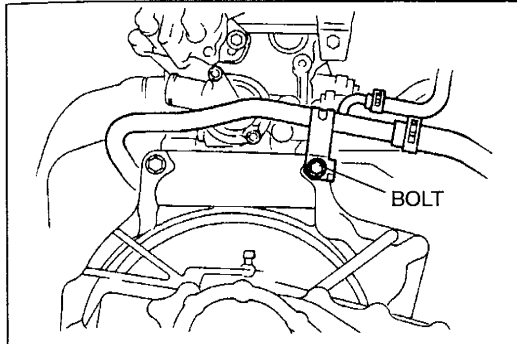

Exhaust manifold

1. Remove the air cleaner and disconnect the air hose. (Refer to page F1-5.)
2. Remove the water bypass pipe stay bolt.

Tightening torque:

64—89 N·m { 6.5—9.1 kgf·m , 48—65 ft·lbf }

3. Loosen the EGR pipe mounting nut.

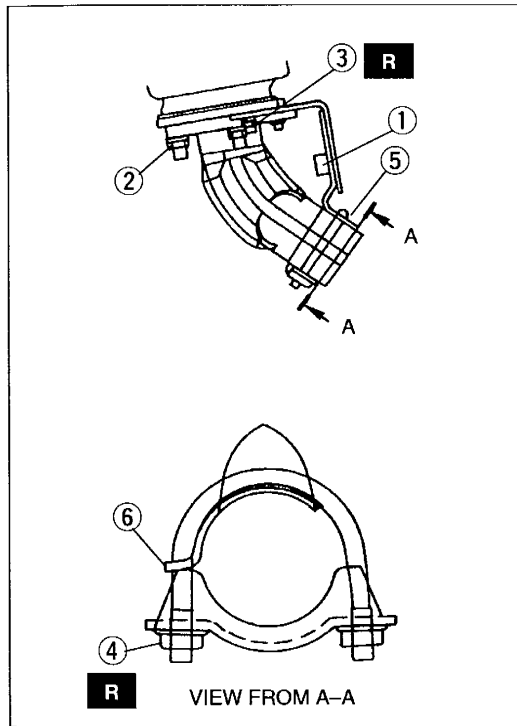

Installation note

Front pipe

1. Hand tighten the bolts and nuts in the order shown.
2. Tighten nut ②.

Tightening torque:

38—51 N·m { 3.8—5.3 kgf·m , 28—38 ft·lbf }

3. Check for correct alignment at ⑤ (front pipe and bracket).
4. Check for correct alignment at ⑥ (hanger bracket and U bolt), then tighten nut ④.

Tightening torque:

10—16 N·m { 100—170 kgf·cm , 87—147 in·lbf }

5. Verify that ③ (frange and bracket) contacts with ① (cylinder block and bracket), then tighten nut ③.

Tightening torque:

19—25 N·m { 1.9—2.6 kgf·m , 14—18 ft·lbf }

6. Tighten bolt ①.

Tightening torque:

38—51 N·m { 3.8—5.3 kgf·m , 28—38 ft·lbf }

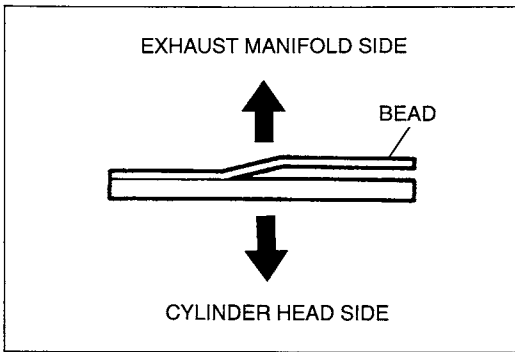

Exhaust manifold

Face the bead of the gasket toward the exhaust manifold as shown, and install the exhaust manifold.

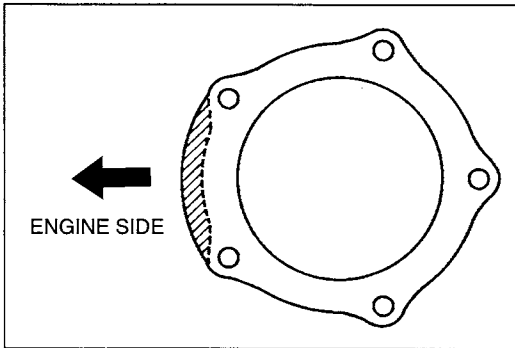

Warm up three way catalytic converter

Install the warm up three way catalytic converter with the shaded area facing toward the engine as shown.

EMISSION SYSTEM

COMPONENT PARTS

Removal / Installation

Fuel tank side

1. Remove the fuel tank. (Refer to page F1-11.)
2. Remove in the order shown in the figure.
3. Install in the reverse order of removal, referring to **Installation note**.

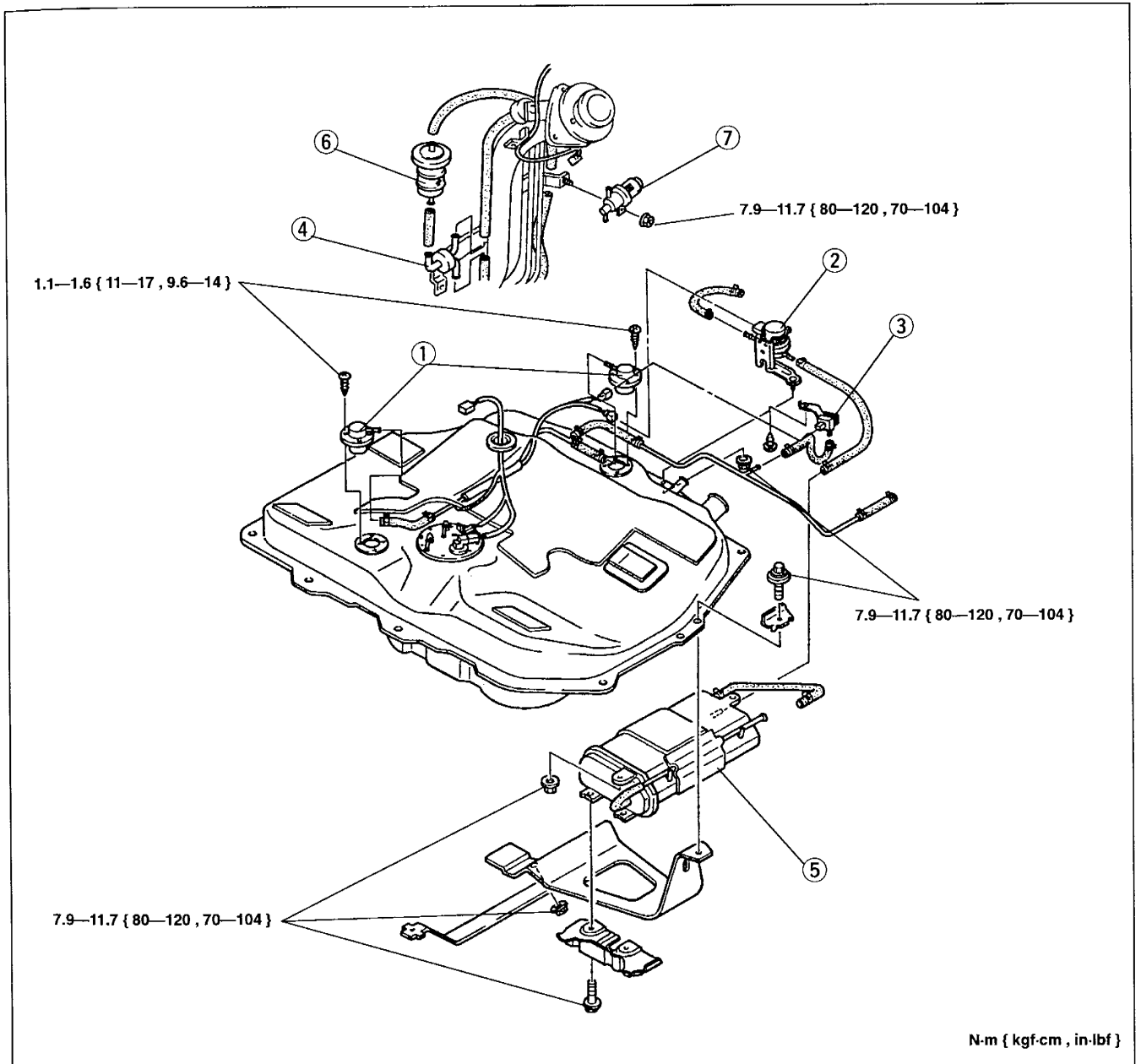

1. Rollover valve
Installation note page F1-28
2. Tank pressure control valve (TPCV)
Installation note page F1-28
3. Fuel tank pressure sensor
4. Check valve (two-way)
Installation note page F1-28

5. Charcoal canister
Installation note page F1-28
6. Air filter
7. Canister drain cut valve (CDCV)

Installation note

Rollover valve, check valve (two-way), tank pressure control valve, charcoal canister

- Push the ends of the evaporative hoses onto respective fittings.

Specification: 15—20 mm { 0.60—0.78 in }
(except charcoal canister)
: 25—30 mm { 0.99—1.18 in }
(charcoal canister)

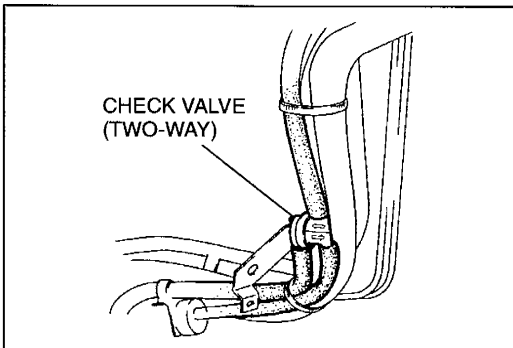
**Check valve (two-way)**

- Push the ends of the evaporative hose onto the fitting.

Specification: 15—20 mm { 0.60—0.78 in }

- Install the check valve (two-way) in the correct direction as shown.

Engine compartment side

1. Disconnect the negative battery cable.
2. Remove the components shown.
3. Install in the reverse order of removal.

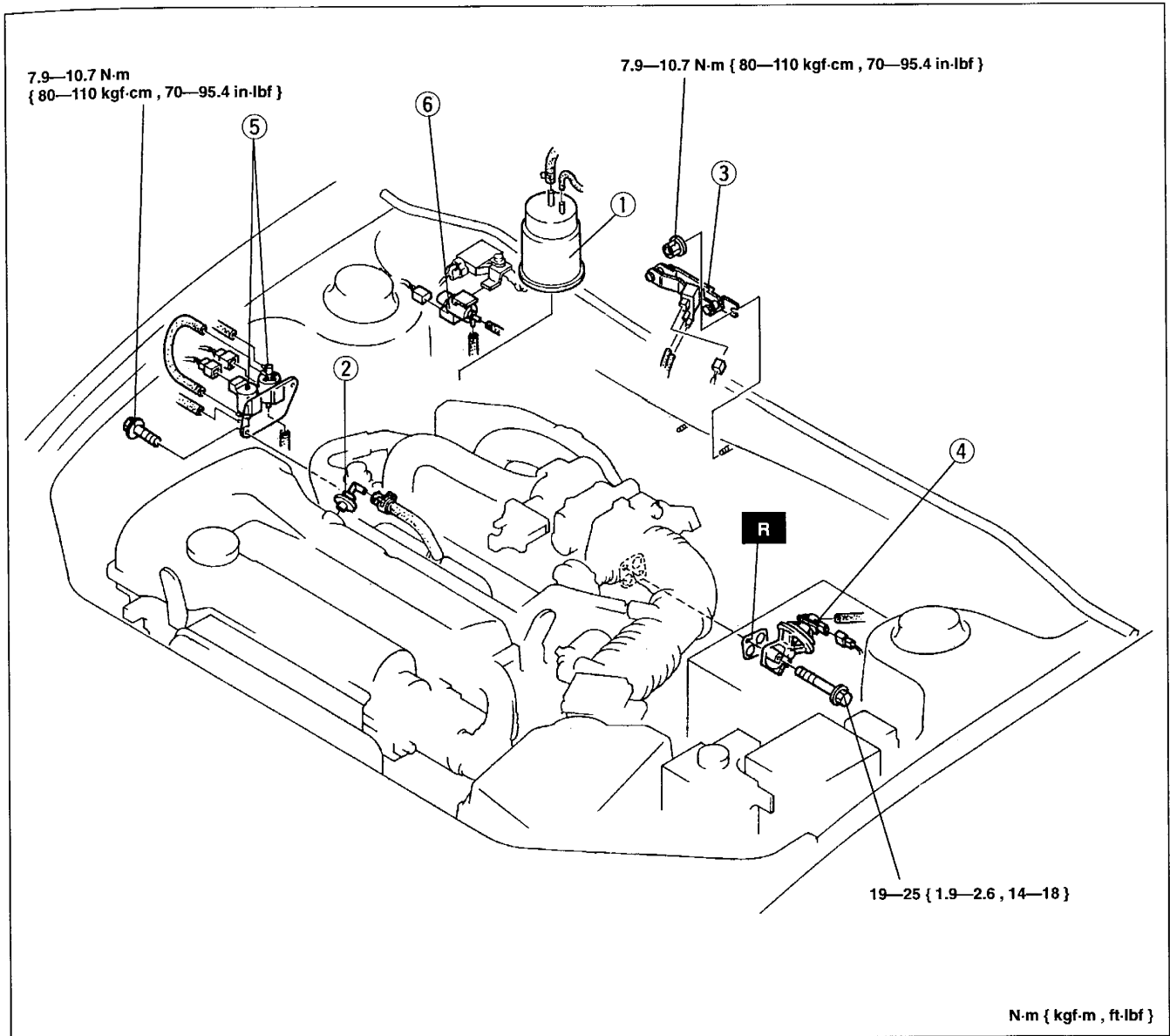

1. Catch tank
2. PCV valve
3. Purge solenoid valve

4. EGR valve
5. EGR solenoid valve
6. EGR boost sensor solenoid valve

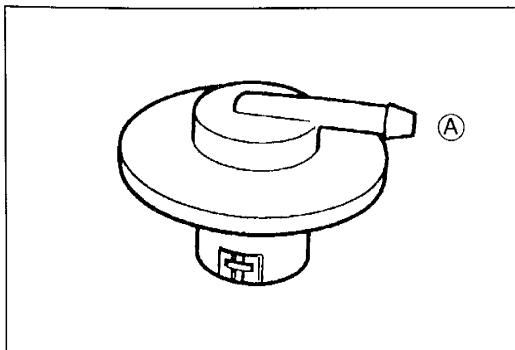

ROLLOVER VALVE

Inspection

1. Remove the fuel tank. (Refer to page F1-11.)
2. Remove the rollover valve. (Refer to page F1-27.)
3. Verify that air flows through the valve from port (A) when the valve is held as shown.

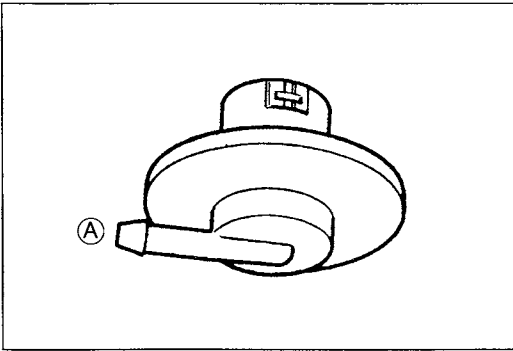

4. Verify that no air flows through the valve from port (A) when the valve is held as shown.
5. If not as specified, replace the rollover valve.

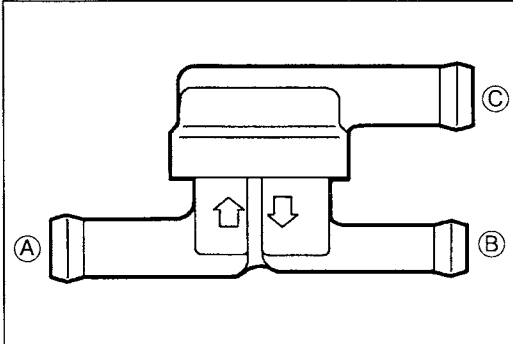

CHECK VALVE

Inspection

Two-way

1. Remove the check valve (two-way). (Refer to page F1-27.)
2. Blow air into port (A) and verify that air smoothly flows from port (C).
3. Blow air into port (C) and verify that air smoothly flows from port (B).
4. If not as specified, replace the check valve (two-way).

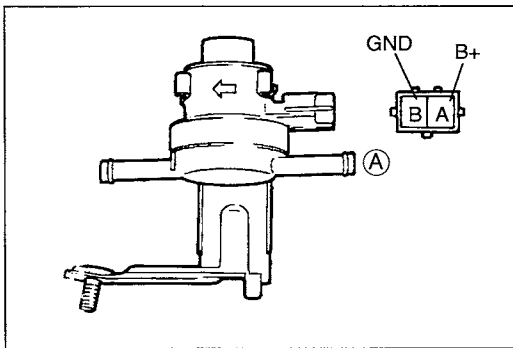

TANK PRESSURE CONTROL VALVE (TPCV)

Inspection

1. Remove the TPCV. (Refer to page F1-27.)
2. Apply pressure or vacuum to port (A) of the valve by using a vacuum pump, and check for the air flow.

Specification

Condition	kPa { mmHg , inHg }	Air flow
Pressure	Below 1.96 { 1.47 , 0.06 }	No
	Above 9.81 { 7.36 , 0.29 }	Yes
Vacuum	Below 9.81 { 7.36 , 0.29 }	Yes

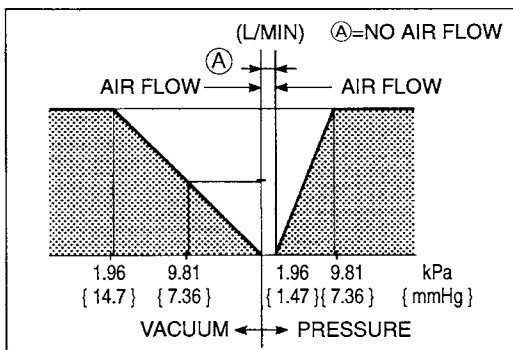

3. Apply battery positive voltage to the valve connector and apply pressure to port (A), and verify that air flows smoothly.
4. If not as specified, replace the TPCV.

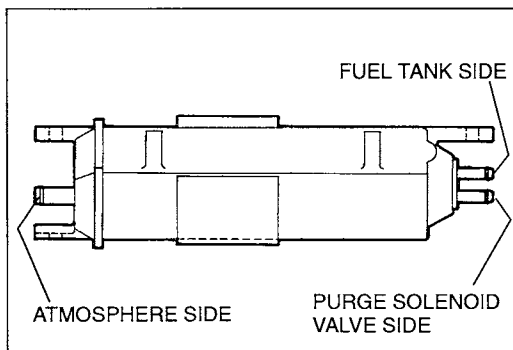

CHARCOAL CANISTER

Inspection

1. Remove the charcoal canister. (Refer to page F1-27.)
2. Plug the charcoal canister vent side port and purge solenoid valve side port.
3. Blow air into the charcoal canister and verify that no air leaks.
4. If air leaks, replace the charcoal canister.

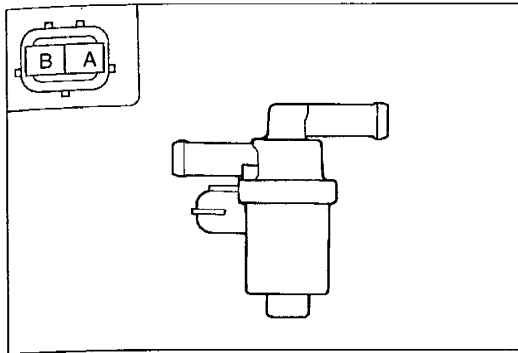

CANISTER DRAIN CUT VALVE (CDCV)

Inspection

1. Remove the canister drain cut valve.
(Refer to page F1-27.)
2. Check for air flow between ports of the solenoid valve.

○—○: Continuity ○—○ : Air flow B+: Battery positive voltage

Step	Terminal		Port	
	A	B	A	B
1	○—○	○—○	○—○	○—○
2	B+	Ground		

3. If not as specified, replace the canister drain cut valve.

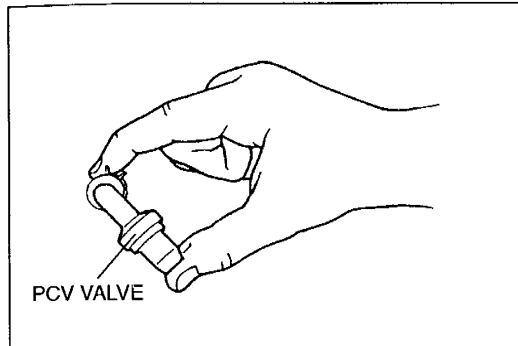

PCV VALVE

Inspection

1. Start the engine and let it idle.
2. Disconnect the PCV valve from the cylinder head cover.
(Refer to page F1-29.)
3. Block the valve opening by hand and verify that vacuum is felt.
4. If not, check the PCV hose for clogging and damage. If the hose is OK, replace the PCV valve.

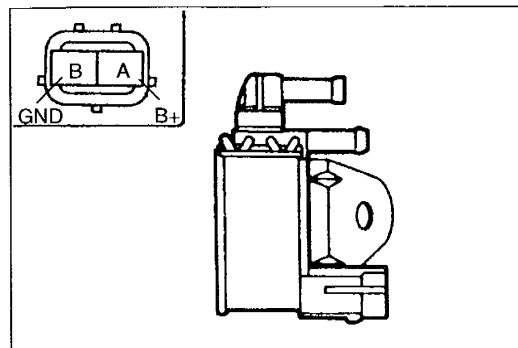

PURGE SOLENOID VALVE

Inspection

1. Remove the purge solenoid valve.
(Refer to page F1-29.)
2. Check for air flow between ports of the solenoid valve.

○—○: Continuity ○—○ : Air flow B+: Battery positive voltage

Step	Terminal		Port	
	A	B	A	B
1	○—○	○—○		
2	B+	Ground	○—○	○—○

3. If not as specified, replace the purge solenoid valve.

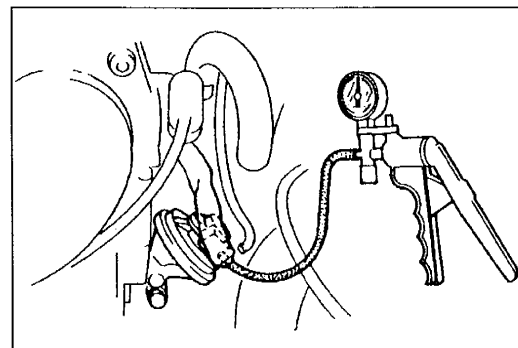

EGR VALVE

Inspection

1. Start the engine and let it idle.
2. Connect a vacuum pump as shown and apply vacuum.
3. Verify that the engine runs roughly or stalls at the specified vacuum.

Specification:

8.7—10.6 kPa { 65—79 mmHg , 2.6—3.1 inHg }

4. If not as specified, replace the EGR valve.
(Refer to page F1-29.)

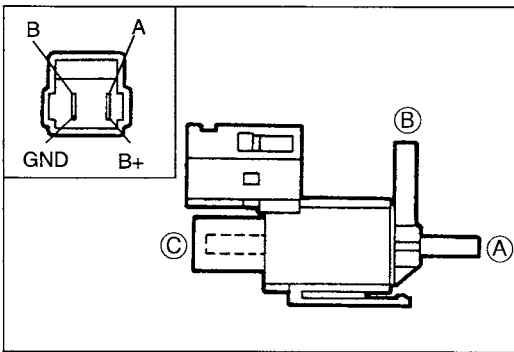
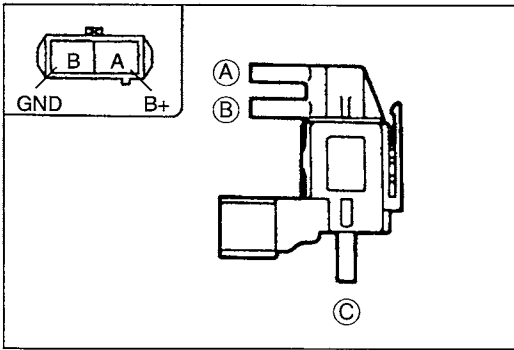
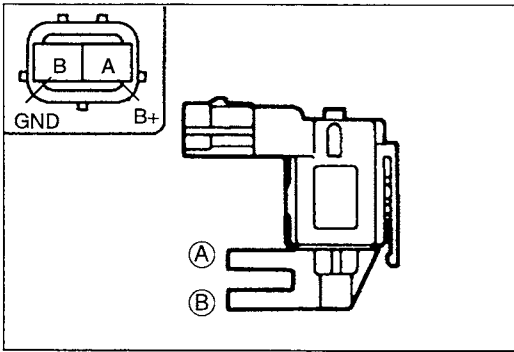

EGR SOLENOID VALVE

Inspection

EGR solenoid valve (vacuum)

1. Remove the EGR solenoid valve (vacuum).
(Refer to page F1-29.)
2. Check for air flow between ports of the solenoid valve.

○—○: Continuity ○—○ : Air flow B+: Battery positive voltage

Step	Terminal		Port	
	A	B	A	B
1	○—○	○—○		
2	B+	Ground	○—○	○—○

3. If not as specified, replace the EGR solenoid valve (vacuum).

EGR solenoid valve (vent)

1. Remove the EGR solenoid valve (vent).
(Refer to page F1-29.)
2. Check for air flow between ports of the solenoid valve.

○—○: Continuity ○—○ : Air flow B+: Battery positive voltage

Step	Terminal		Port		
	A	B	A	B	C
1	○—○	○—○	○—○	○—○	○—○
2	B+	Ground	○—○	○—○	

3. If not as specified, replace the EGR solenoid valve (vent).

EGR BOOST SENSOR SOLENOID VALVE

Inspection

1. Remove the EGR boost sensor solenoid valve.
(Refer to page F1-29.)
2. Check for air flow between ports of the solenoid valve.





○—○: Continuity ○—○ : Air flow B+: Battery positive voltage

Step	Terminal		Port		
	A	B	A	B	C
1	○—○	○—○		○—○	○—○
2	B+	Ground	○—○	○—○	

3. If not as specified, replace the EGR boost sensor solenoid valve.

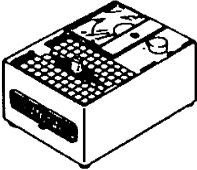
CONTROL SYSTEM

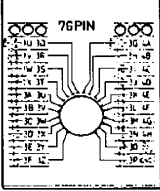
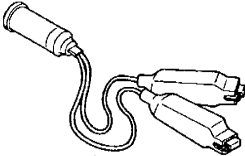
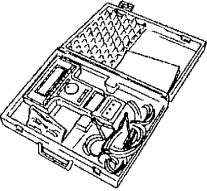
PREPARATION
SST

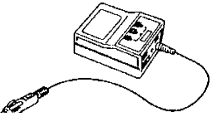
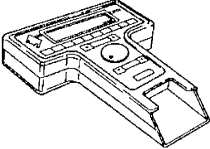
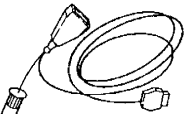
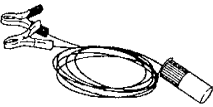
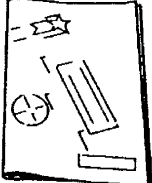
<p>49 9200 162A Engine Signal Monitor</p> 	<p>For inspection of PCM terminal voltage</p>	<p>49 T018 902 Harness adapter</p> 	<p>For inspection of PCM terminal voltage</p>
<p>49 F018 903 Sheet</p> 	<p>For inspection of PCM terminal voltage</p>	<p>49 D088 008 Harness adapter, Power</p> 	<p>For inspection of PCM terminal voltage</p>
<p>49 T088 0A0 NGS set</p> 	<p>For inspection of PCM and input/output devices</p>	<p>49 T088 010B Program Card</p> 	<p>For inspection of PCM and input/output devices</p>
<p>49 T088 002 Vehicle Interface Module (Part of 49 T088 0A0)</p> 	<p>For inspection of PCM and input/output devices</p>	<p>49 T088 001 Control Unit (Part of 49 T088 0A0)</p> 	<p>For inspection of PCM and input/output devices</p>
<p>49 T088 004 NGS OBDII Adapter (Part of 49 T088 0A0)</p> 	<p>For inspection of PCM and input/output devices</p>	<p>49 T088 006 Battery Hookup Adapter (Part of 49 T088 0A0)</p> 	<p>For inspection of PCM and input/output devices</p>
<p>49 T088 008A Instruction Manual</p> 	<p>For inspection of PCM and input/output devices</p>	<p>—</p>	<p>—</p>

COMPONENT PARTS

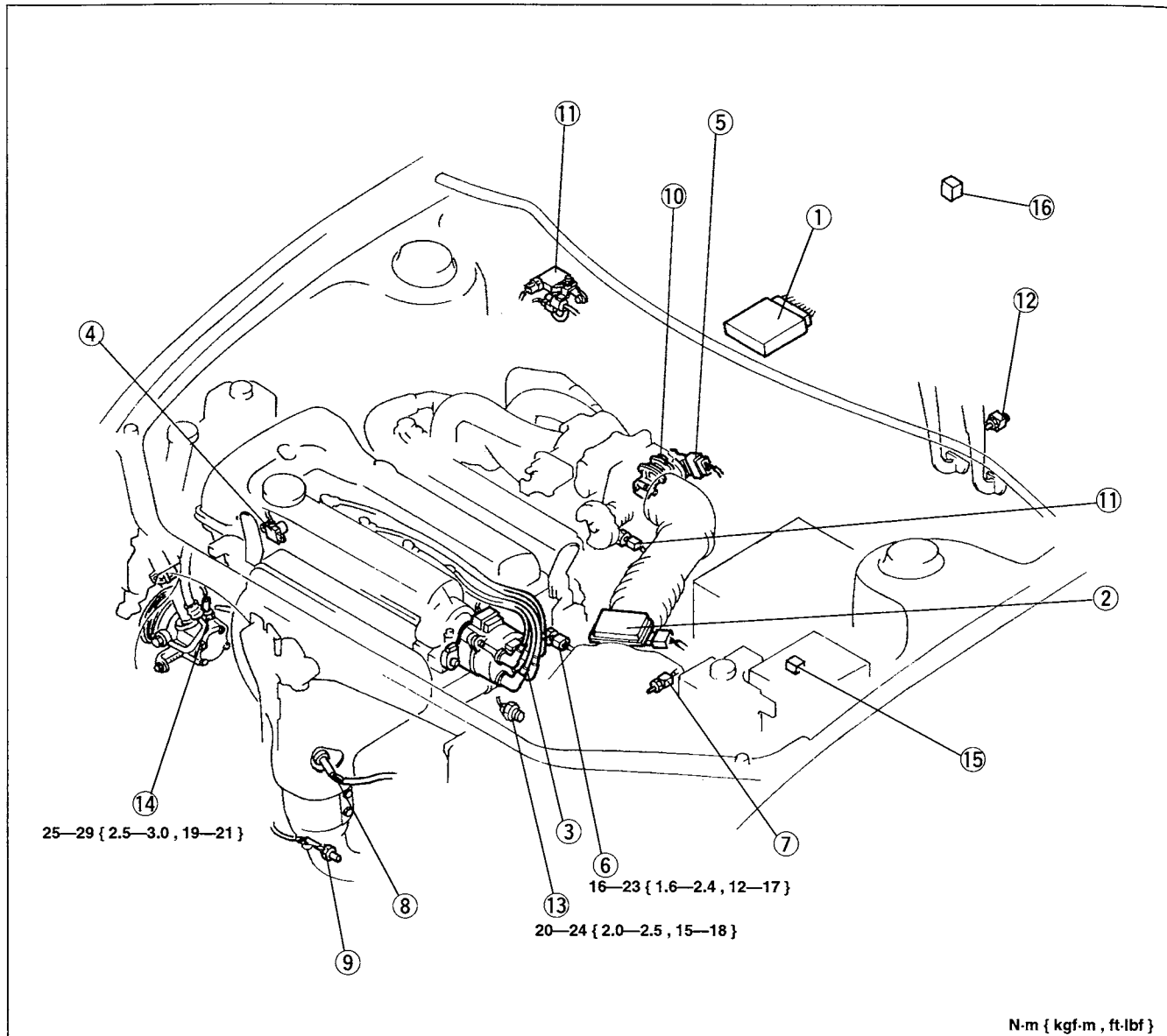

- | | |
|--|--|
| 1. Powertrain control module (PCM)
Removal / Installation page F1-35
Inspection page F1-36 | 9. Heated oxygen sensor (Rear)
Inspection page F1-48 |
| 2. Mass air flow sensor
Inspection page F1-43 | 10. EGR valve position sensor
Inspection page F1-49 |
| 3. Camshaft position sensor
Inspection page F1-44 | 11. EGR boost sensor
Inspection page F1-50 |
| 4. Crankshaft position sensor
Inspection page F1-44
Replacement page F1-45 | 12. Clutch switch
Inspection page F1-52
Replacement page F1-52 |
| 5. Throttle position sensor
Inspection page F1-45
Adjustment page F1-46 | 13. Neutral switch
Inspection page F1-52 |
| 6. Engine coolant temperature sensor
Inspection page F1-48 | 14. Power steering pressure switch
Inspection page F1-52 |
| 7. Intake air temperature sensor
Inspection page F1-48 | 15. Main relay
Inspection page F1-53 |
| 8. Heated oxygen sensor (Front)
Inspection page F1-48 | 16. Fuel tank pressure sensor
Inspection page F1-51 |

POWERTRAIN CONTROL MODULE (PCM)**Removal / Installation**

1. Disconnect the negative battery cable.
2. Remove the rear console, front console and undercover. (Refer to section S.)
3. Remove in the order shown in the figure.
4. Install in the reverse order of removal.

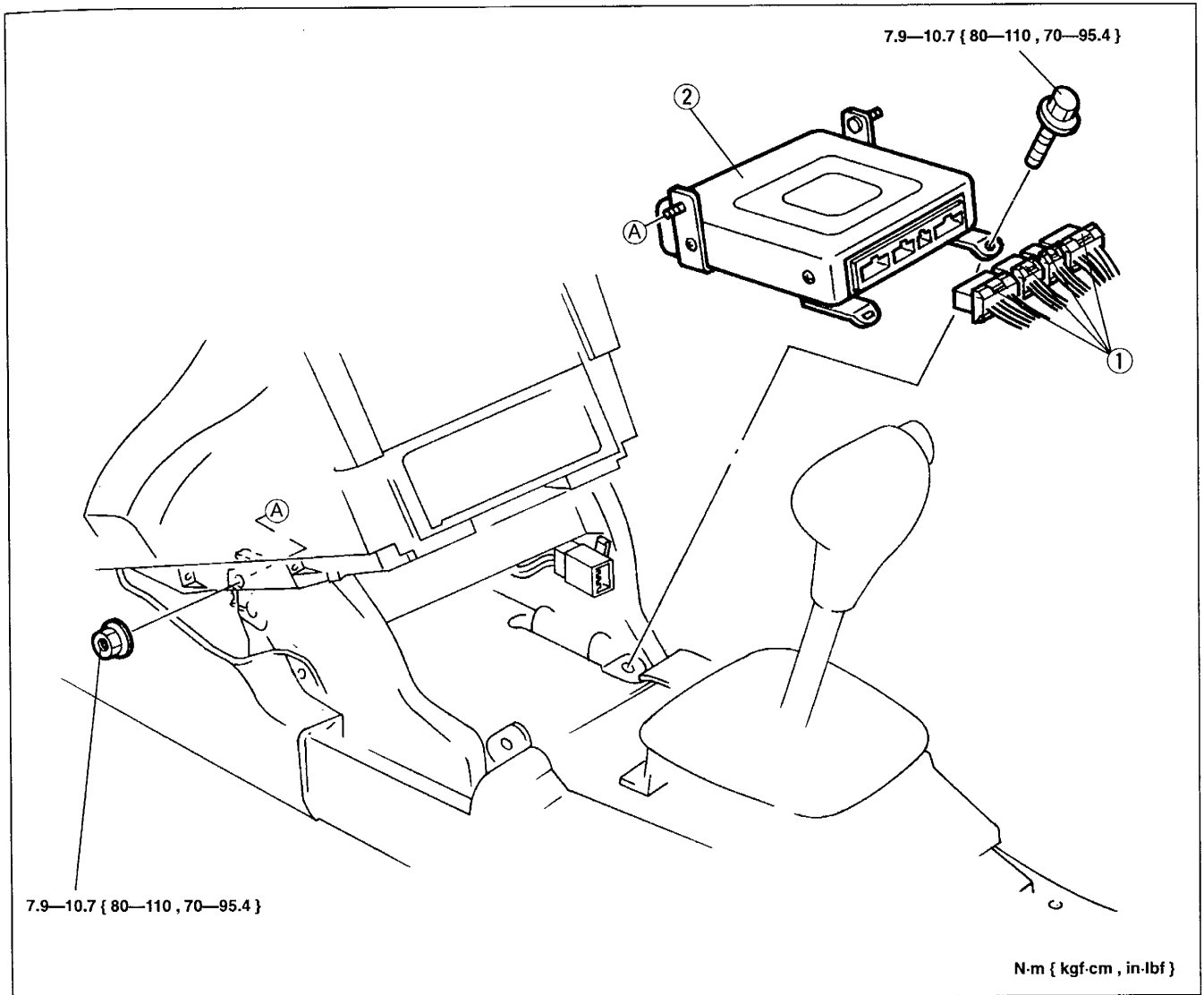

1. PCM connectors

2. Powertrain control module (PCM)

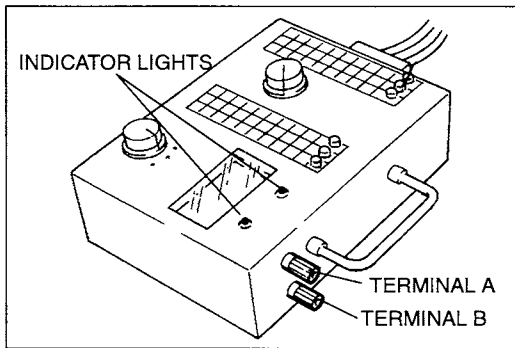
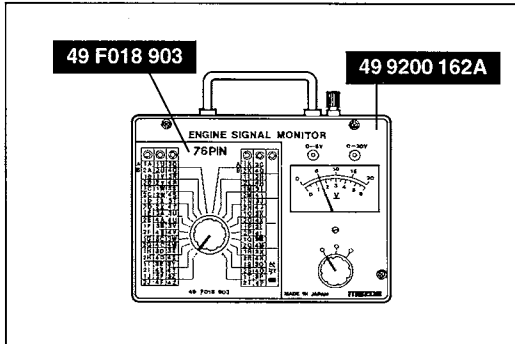
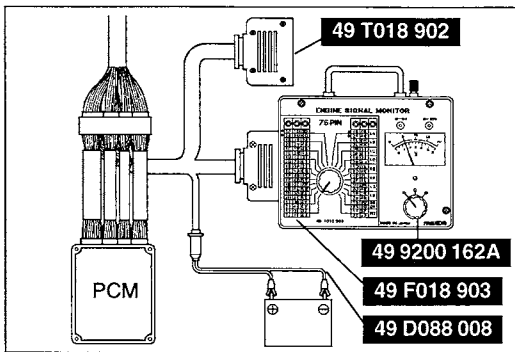

Inspection

Caution

- The PCM terminal voltages vary with change in measuring conditions and vehicle conditions. Always carry out a total inspection of the input systems, output systems, and PCM to determine the cause of trouble. Otherwise, a wrong diagnosis will be made.

1. Disconnect the negative battery cable.
2. Remove the rear console, front console and undercover. (Refer to section S.)
3. Disconnect the PCM connector.
4. Connect the **SST** (Harness adapter) to the PCM connector.
5. Connect the **SSTs** (Engine Signal Monitor and Harness adapter, power) to the **SST** (Harness adapter). Use connector A of the harness adapter for PCM terminals 1A through 1V and 3A through 3P. Use connector B for PCM terminals 2A through 2L and 4A through 4Z.
6. Place the **SST** (Sheet) on the **SST** (Engine Signal Monitor).
7. Measure the voltage at each PCM terminal by switching the selector switch and the monitor switch.
8. If any incorrect voltage is detected, check related systems, wiring harnesses and connectors referring to the possible malfunction in the terminal voltage list.

Caution

- Disconnecting the connectors of the PCM and the **SST** (Harness adapter) while the battery is connected can damage the PCM and the **SST** (Engine Signal Monitor). Disconnect the negative battery cable and the **SST** (Harness adapter, power) before disconnecting the connectors.
- Applying voltage to terminals A and B of the **SST** (Engine Signal Monitor) can damage the **SST** (Engine Signal Monitor).

Note

- The indicator lights of the **SST** (Engine Signal Monitor), provided for confirmation of the voltmeter range, is also used for detection of the pulse such as the fuel injector control signal, which is difficult to detect by using the voltmeter.
- Terminals A and B of the **SST** (Engine Signal Monitor) are for connection of an external instrument. By connecting an external instrument such as a circuit tester or an oscilloscope, various inspections in addition to the measurement of the PCM terminal voltages are made possible.

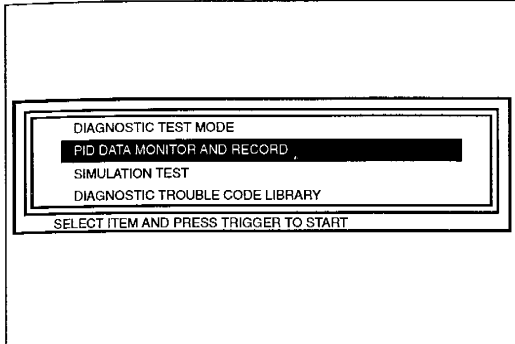
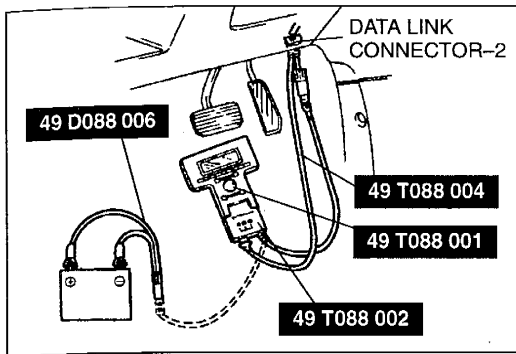

Using SST (NGS)

1. In the passenger compartment, connect the **SST (NGS)** to the data link connector-2 as shown in the figure.
2. Referring to the NGS operational manual, select the **PID/DATA MONITOR AND RECORD** function.
3. Referring to the 1996 Service Highlights, inspect each PCM input/output signal.

Note

- The **PID DATA MONITOR AND RECORD** function is to monitor the calculation value of input/output signals in the PCM. Deviation in the value does not always indicate malfunction in the related input/output devices.
- When normal output signal cannot be detected when all input signals are normal, replace the PCM.

Terminal voltage (Reference)

B+: Battery positive voltage

*1: In data link connector

*2: ATX only

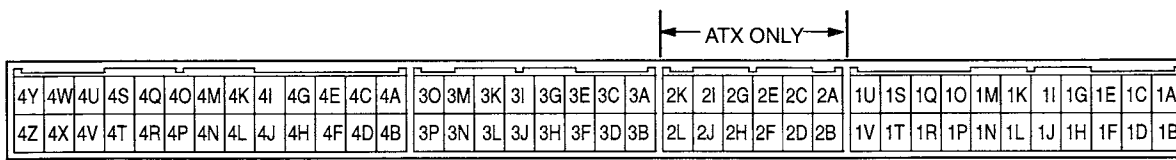

Terminal	Signal	Connected to	Test condition		Voltage (V)	Possible malfunction
1A*2	Condenser fan control	Condenser fan relay	Idle	Condenser fan operating	Below 1.0	• Condenser fan relay (Refer to section U)
				Condenser fan stop	B+	
1B	Cooling fan control	Cooling fan relay	Ignition switch ON	Cooling fan operating/ Terminal *1TEN ground and throttle valve open	Below 1.0	• Cooling fan relay (Refer to section E)
				Cooling fan stop	B+	
1C	—	—	—	—	—	—
1D	Serial communication	Data link connector-2 terminal KLN	Carry out inspection according to diagnostic trouble code Diagnostic trouble code output is a part of serial communication Judgement by terminal voltage is not possible (Refer to page F1-54)		—	• On-board diagnostic system
1E	MIL	Malfunction indicator lamp	Malfunction indicator lamp OFF		B+	• PCM terminal 1E — MIL
			Malfunction indicator lamp ON		Below 1.0	
1F	—	—	—	—	—	—
1G	A/C control	A/C relay	Ignition switch ON		B+	• A/C relay (Refer to section U)
			Idle	A/C operating	Below 1.0	
				A/C stop	B+	
1H	Headlight	Headlight switch	Headlight switch OFF		Below 1.0	• Headlight switch (Refer to section T)
			Headlight switch ON		B+	
1I	Diagnostic test mode	Data link connector (Terminal TEN)	Ignition switch ON	Open terminal *1TEN	B+	• PCM terminal 1I – *1TEN harness
				Short terminal *1TEN	Below 1.0	
1J	Rear window defroster	Rear window defroster switch	Ignition switch ON	Rear window defroster switch OFF	Below 1.0	• Rear window defroster switch (Refer to section T)
				Rear window defroster switch ON	B+	
1K	A/C	A/C amplifier	Idle	A/C switch and blower switch ON	Below 1.2	• A/C switch • Refrigerant pressure switch • A/C amplifier (Refer to section U)
				A/C switch OFF	B+	
1L	Load/No load distinction	Neutral/clutch switch (MTX), Transaxle range switch (ATX)	Ignition switch ON	MTX Other than neutral position and clutch pedal released	B+	• Neutral switch (Refer to page F1-52) • Clutch switch (Refer to page F1-52) • Transaxle range switch (Refer to section K)
				ATX Other than P or N position		
				MTX Neutral position or clutch pedal depressed	Below 1.0	
				ATX P or N position		

B+: Battery positive voltage
 *1: In data link connector
 *2: ATX only

Terminal	Signal	Connected to	Test condition		Voltage (V)	Possible malfunction
1M	Vehicle speed	Vehicle speed sensor	Ignition switch ON		0 or 4.0	• Vehicle speed sensor (Refer to section T)
			Driving		Approx. 3.0	
1N	DRL (CANADA)	DRL unit	Daytime running light ON		Below 1.0	• DRL unit (Refer to section T)
			Daytime running light OFF		Above 11.0	
1O	—	—	—		—	—
1P	Blower	Fan switch	Ignition switch ON	Fan switch OFF or ON at 1st	B+	• Fan switch (Refer to section U)
				Fan switch ON at 2nd or higher	Below 1.0	
1Q	Brake	Brake switch	Brake pedal released		Below 1.0	• Brake switch (Refer to section P)
			Brake pedal depressed		B+	
1R	—	—	—		—	—
1S	—	—	—		—	—
1T	—	—	—		—	—
1U	Fuel pump control	Fuel pump relay	Ignition switch ON		B+	• Fuel pump relay (Refer to page F1-22)
			Cranking		Below 1.0	
			Idle			
1V	—	—	—		—	—
*2A	Shift solenoid A control	Shift solenoid A	During shifting		B+	• Shift solenoid A (Refer to section K)
			Others		0	
*2B	Shift solenoid B control	Shift solenoid B	During shifting		B+	• Shift solenoid B (Refer to section K)
			Others		0	
*2C	Shift solenoid C control	Shift solenoid C	During shifting		B+	• Shift solenoid C (Refer to section K)
			Others		0	
*2D	Torque converter clutch solenoid control	Torque converter clutch solenoid	During shifting		B+	• Torque converter clutch solenoid (Refer to section K)
			Others		0	
*2E	O/D OFF indicator light control	O/D OFF indicator light	Ignition switch ON	O/D OFF mode	Below 1.0	• Instrument cluster (O/D OFF indicator) (Refer to section K)
				Others	B+	
*2F	D range	Transaxle range switch (D range)	Idle	D range	B+	• Transaxle range switch (Refer to section K)
				Others	0	
*2G	2 range	Transaxle range switch (2 range)	Idle	2 range	B+	
				Others	0	
*2H	1 range	Transaxle range switch (1 range)	Idle	1 range	B+	
				Others	0	
*2I	O/D OFF switch	O/D OFF switch	Ignition switch ON	O/D OFF switch pressed	Below 1.0	• O/D OFF switch (Refer to section K)
				O/D OFF switch released	B+	
2J	—	—	—		—	—
*2K	Input/turbine speed sensor	Input/turbine speed sensor (turbine)	Ignition switch ON		Approx. 2.5	• Input/turbine speed sensor (Refer to section K)
			Idle			
*2L	Input/turbine speed sensor ground	Input/turbine speed sensor (ground)	Constant		Below 2.5	• PCM 2L terminal continuity harness (Refer to section K)

B+: Battery positive voltage

*1: In data link connector

*2: ATX only

Terminal	Signal	Connected to	Test condition		Voltage (V)	Possible malfunction
3A	Fuel tank pressure	Fuel tank pressure sensor	Ignition switch ON	Fuel tank pressure 0 kPa { 0 mmHg , 0 inHg } (Barometric Pressure)	Approx. 2.5	• Fuel tank pressure sensor
3B	Mass air flow sensor (HWP)	Mass air flow sensor	Ignition switch ON		Below 1.5	• Mass air flow sensor (Refer to page F1-43)
			Idle		1.0—2.5	
3C	Heated oxygen sensor (Front)	Heated oxygen sensor (Front)	Ignition switch ON		Approx. 0	• Heated oxygen sensor (Front) (Refer to page F1-48)
			Idle	Engine cold	0—0.9	
				After warm up	0—1.0	
			Acceleration		0.5—1.0	
Deceleration	0—0.5					
3D	Heated oxygen sensor (Rear)	Heated oxygen sensor (Rear)	Ignition switch ON		Approx. 0	• Heated oxygen sensor (Rear) (Refer to page F1-48)
			Idle	Engine cold	Below 1.0	
				After warm up	0—1.0	
			Acceleration		0—1.0	
Deceleration	0—1.0					
*23E	Transaxle fluid temperature	Trasaxle fluid temperature sensor	Ignition switch ON	Transaxle fluid temperature 20 °C { 68 °F }	Approx. 5	• Transaxle fluid temperature sensor (Refer to section K)
				Transaxle fluid temperature 130 °C { 266 °F }	Approx. 1.5	
3F	Throttle position (TVO)	Throttle position sensor	Ignition switch ON	Closed throttle position	0.3—0.7	• Throttle position sensor (Refer to page F1-45) • PCM terminal 3I voltage
				Wide open throttle	3.4—5.3	
3G	Engine coolant temperature	Engine coolant temperature sensor	Ignition switch ON	Engine coolant temp 20 °C { 68 °F }	Approx. 5.0	• Engine coolant temperature sensor (Refer to page F1-48)
				After warm up	Below 1.0	
3H	Barometric pressure/EGR boost	EGR boost sensor	Ignition switch ON		Approx. 4.5	• EGR boost sensor (Refer to page F1-50)
			Idle			
3I	Constant voltage (Vref)	Throttle position sensor EGR valve position sensor	Ignition switch ON		Approx. 5.0	• PCM terminal 4B voltage
3J	EGR valve position	EGR valve position sensor	Ignition switch ON		Approx. 0.8	• EGR valve position sensor (Refer to page F1-49) • PCM terminal 3I voltage
			Idle			
3K	Intake air temperature	Intake air temperature sensor	Ignition switch ON	Intake air temperature 20 °C { 68 °F }	Approx. 2.2	• Intake air temperature sensor (Refer to page F1-48)
3L	—	—	—		—	—
3M	Heated oxygen sensor heater	Heated oxygen sensor	Ignition switch ON	Idle	Below 1.0	• Heated oxygen sensor (Refer to page F2-48)
3N	—	—	—		—	—
3O	Analogue sensor ground	Ground	Constant		Below 1.0	• PCM 3O terminal harness (Open)

B+: Battery positive voltage
 *1: In data link connector
 *2: ATX only

Terminal	Signal	Connected to	Test condition		Voltage (V)	Possible malfunction
3P	Power steering pressure	Power steering pressure switch	Ignition switch ON		B+	• Power steering pressure switch (Refer to page F1-52)
			Idle	P/S not operating		
				P/S operating	Below 1.0	
4A	PCM ground	Ground	Constant		Below 1.0	• PCM 4A harness (Open)
4B	Power supply	Main relay (FUEL INJ relay)	Ignition switch	OFF	Below 1.0	• Main relay (Refer to page F1-53)
				ON	B+	
4C	Fuel injector ground	Ground	Constant		Below 1.0	• PCM 4C terminal continuity harness (Open)
4D	Output device ground	Ground	Constant		Below 1.0	• PCM 4D terminal continuity harness (Open)
4E	NE⊖	Crankshaft position sensor	Ignition switch ON		Approx. 2.4	• Crankshaft position sensor (Refer to page F1-44)
			Idle			
4F	SGT	Camshaft position sensor (In distributor)	Ignition switch ON		0 or Approx. 5.0	• Camshaft position sensor (Refer to page F1-44)
			Idle		Approx. 2.0	
4G	SGC (California only)	Camshaft position sensor (In distributor)	Ignition switch ON		0 or Approx. 5.0	
			Idle		Approx. 2.5	
4H	NE⊕	Crankshaft position sensor	Ignition switch ON		Approx. 2.4	• Crankshaft position sensor (Refer to page F1-44)
			Idle			
4I	Back-up power supply	Battery	Constant		B+	• PCM 4I terminal — battery harness and connector
4J	Pressure regulator control (except California)	PRC solenoid valve	Idle (Hot condition)		Below 1.0	• PRC solenoid valve (Refer to page F1-22)
			Other		B+	
4K	—	—	—		—	—
4L	EGR boost sensor switching control	EGR boost sensor solenoid valve	Ignition switch ON		B+	• EGR boost sensor solenoid valve (Refer to page F1-28)
			Idle			
4M	Fuel level	Fuel gauge sender unit	Ignition switch ON	Full fuel	Approx. 6	• Fuel gauge sender unit (Refer to section T)
				Low fuel	Approx. 0	
4N	IGT	Ignition control module (In distributor)	Ignition switch ON		Below 1.0	• Ignition control module (Refer to section G)
			Idle		Approx. 0.3	
4O	EGR control (Vent)	EGR solenoid valve (Vent)	Ignition switch ON		B+	• EGR solenoid valve (Vent) (Refer to page F1-28)
			Idle			
4P	EGR control (Vacuum)	EGR solenoid valve (Vacuum)	Ignition switch ON		B+	• EGR solenoid valve (Vacuum) (Refer to page F1-28)
			Idle			
4Q	Idle air control	Idle air control valve	Ignition switch ON		Approx. 0.7	• Idle air control valve (Refer to page F1-8)
			Idle	After warm up (No load)	Approx. 10*	
4R	—	—	—		—	—
4S	—	—	—		—	—

* Engine Signal Monitor: Green and red lights flash

B+: Battery positive voltage
 *1: In data link connector
 *2: ATX only

Terminal	Signal	Connected to	Test condition	Voltage (V)	Possible malfunction
4T	Purge control	Purge solenoid valve	Ignition switch ON	B+	<ul style="list-style-type: none"> • Purge solenoid valve (Refer to page F1-27)
			Idle		
4U	Fuel injector control	Fuel injector No.1	Ignition switch ON	B+	<ul style="list-style-type: none"> • Fuel injector (Refer to page F1-20)
4V		Fuel injector No.2		Idle	
4W		Fuel injector No.3			
4X		Fuel injector No.4			
4Y	—	—	—	—	—
4Z	CDCV, TPCV control	CDCV, TPCV	Ignition switch ON	B+	<ul style="list-style-type: none"> • CDCV (Refer to page F1-31) • TPCV (Refer to page F1-30)
			Diagnosis executed	Below 1.0	

* Engine Signal Monitor: Green and red lights flash

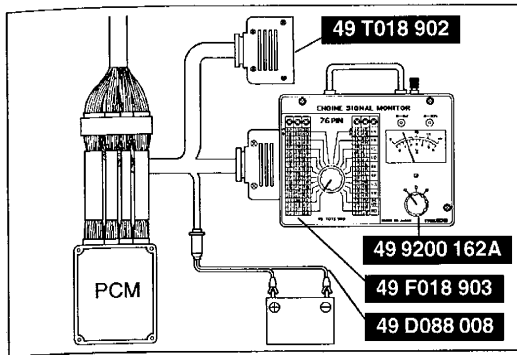

MASS AIR FLOW SENSOR

Inspection

1. Check the mass air flow sensor for damage and cracks.
2. Connect the **SSTs** (Engine signal Monitor) to the PCM. (Refer to page F1-36.)
3. Measure the voltage at PCM terminal 3B. (Refer to page F1-40.)
4. Verify that the voltage is within the specification.

Specification

Measuring condition	PCM terminal 3B voltage (V)
Ignition switch ON	Below 2.0
Idle	1.0—2.5

5. If not as specified, inspect the harness and connector between the mass air flow sensor and the PCM terminal.
6. If there is correct terminal voltage and harness continuity, replace the mass air flow sensor. (Refer to page F1-5.)

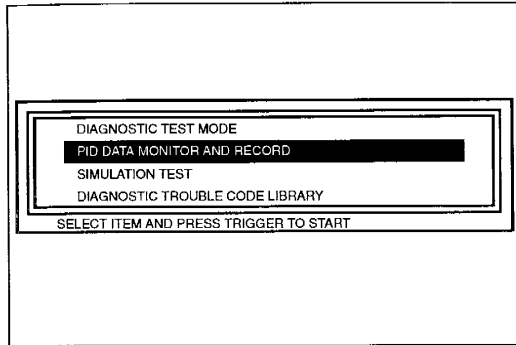

Using the NGS

1. Check the mass air flow sensor for damage and cracks.
2. Connect the **SSTs** (NGS) to the data link connector-2. (Refer to page F1-37.)
3. Select the PID/DATA MONITOR AND RECORD function.
4. Select “MAF V” on the NGS display. The NGS measures and shows the voltage.

Specification

Measuring condition	Mass air flow signal Voltage (V)
Ignition switch ON	Below 1.0
Idle	1.0—2.5

5. If not as specified, inspect the harness and connector between the mass air flow sensor and the PCM terminal.
6. If there is correct terminal voltage and harness continuity, replace the mass air flow sensor. (Refer to page F1-5.)

Note

- The scan tool shows the mass air flow rate and load value.

Specification

	Intake mass air flow (g/s)		Engine load calculated value (%)	
	MTX	ATX	MTX	ATX
Idle*	1.4—2.0	1.7—2.4	13.0—19.0	14.0—21.0
Engine speed 2,500 rpm*	5.0—6.4	6.2—7.8	12.0—18.0	16.0—22.0

*: No load, neutral or P position

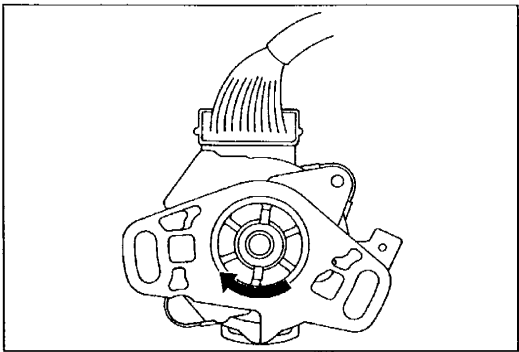

CAMSHAFT POSITION SENSOR

Inspection

1. Remove the distributor. (Refer to section G.)
2. Disconnect the fuel injector connector.
3. Connect the distributor connector. (6-pin connector for California)

Warning

- Turning the ignition switch on with the fuel injector connector still connected will actuate the fuel injector.
- Turning the ignition switch on with the high tension lead still connected will generate sparks, which can cause electrical shock. Disconnect the connector and avoid it from grounding to the vehicle body.

4. Connect the SSTs (Engine Signal Monitor) to the PCM. (Refer to page F1-36.)
5. Turn the ignition switch to ON.
6. Measure the voltage at PCM terminals 4F and 4G. (Refer to page F1-41.)
7. Rotate the distributor drive by hand and check the output signal.

Specification

PCM terminal	Signal	
4F	SGT	Approx. 5 V (4 pulses/rev)
4G (CALIFORNIA)	SGC	Approx. 5 V (1 pulse/rev)

8. If not as specified, inspect the wiring harness and connector between the distributor and the PCM terminal.
9. If there is correct terminal voltage and harness continuity, replace the distributor. (Refer to section G.)

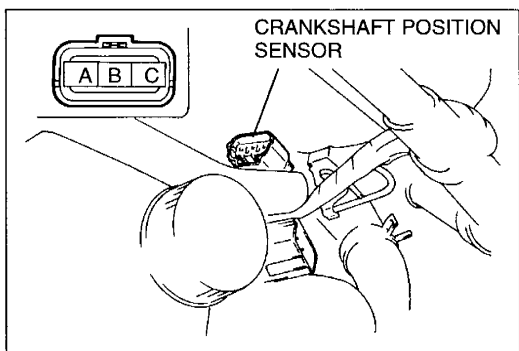

CRANKSHAFT POSITION SENSOR

Inspection

Resistance

1. Disconnect the crankshaft position sensor connector.
2. Measure the resistance between terminals A and B by using an ohmmeter.

Specification: 500—600 Ω [20 °C { 68 °F }]

3. If not as specified, replace the crankshaft position sensor. (Refer to page F1-45.)

Air gap

1. Measure the air gap between the crankshaft pulley and the crankshaft position sensor by using a feeler gauge.

Specification: 0.5—1.5 mm { 0.020—0.059 in }

2. If not as specified, replace the crankshaft pulley or the crankshaft position sensor. (Refer to page F1-45.)

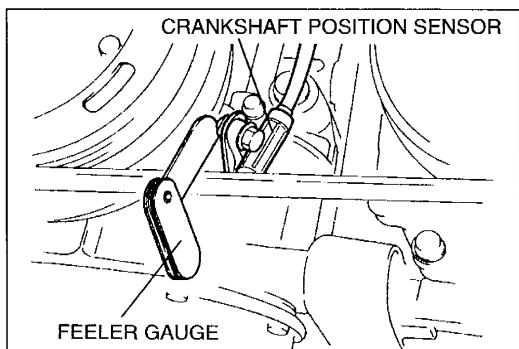

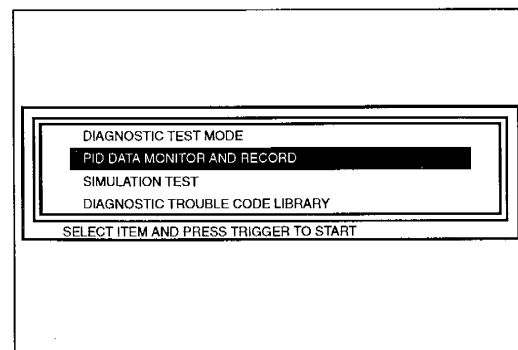
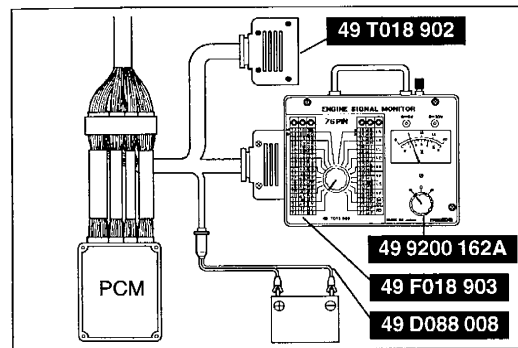
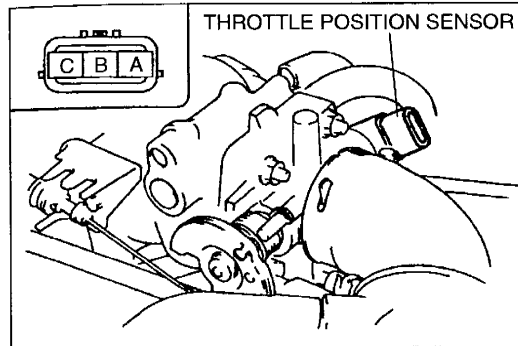
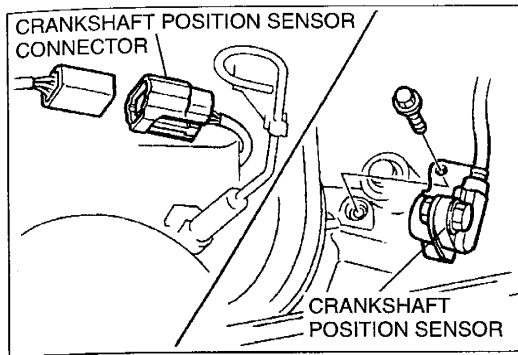

Replacement

1. Remove the undercover.
2. Remove the crankshaft position sensor.
3. Install in the reverse order of removal.

Tightening torque:

7.9—10.7 N·m { 80—110 kgf·cm , 70—95.4 in·lbf }

THROTTLE POSITION SENSOR

Inspection

Using ohmmeter

1. Disconnect the throttle position sensor connector.
2. Measure the resistance between throttle position sensor connector terminals A and C by using an ohmmeter.

Specification: 4.0—6.0 kΩ

3. If not as specified, replace the throttle position sensor.
4. Connect the throttle position sensor connector.
5. Adjust the throttle position sensor after installation.

Using the Engine Signal Monitor

1. Remove the PCM. (Refer to page F1-35.)
2. Connect the **SSTs** (Engine Signal Monitor) to the PCM. (Refer to page F1-36.)
3. Verify that the throttle valve is at the closed throttle position.
4. Turn the ignition switch to ON.
5. Measure the voltage at the PCM terminal 3F. (Refer to page F1-40.)

Specification

Measuring condition	Voltage (V)
Closed throttle position	0.3—0.7
Wide open throttle	3.4—5.3
Closed throttle position→Wide open throttle	Increases smoothly

6. If not as specified, adjust the throttle position sensor.

Using the NGS

1. Connect the **SSTs** (NGS) to the data link connector-2. (Refer to page F1-37.)
2. Verify that the throttle valve is at the closed throttle position.
3. Select the PID/DATA MONITOR AND RECORD function.
4. Select "TP V" on the NGS display. The NGS measures and shows the voltage.

Specification

Measuring condition	Voltage (V)
Closed throttle position	0.3—0.7
Wide open throttle	3.4—5.3
Closed throttle position→Wide open throttle	Increases smoothly

5. If not as specified, adjust the throttle position sensor.

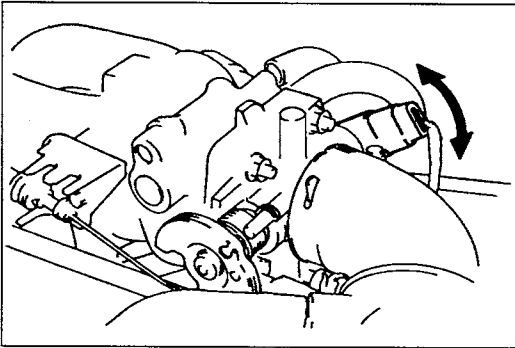
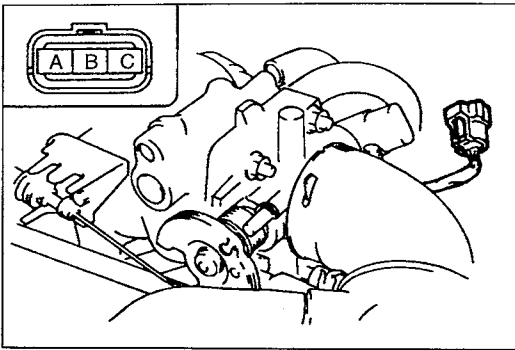

Adjustment

1. Verify that the throttle valve is at the closed throttle position.
2. Disconnect the throttle position sensor connector.
3. Turn the ignition switch to ON.
4. Measure and record the voltage at the harness side connector terminal C by using the voltmeter.

Specification: 4.5—5.5 V

5. Connect the throttle position sensor connector.
6. Remove the PCM. (Refer to page F1-35.)
7. Connect the **SSTs** (Engine Signal Monitor) to the PCM. (Refer to page F1-36.)
8. Verify that the throttle valve is at the closed throttle position.
9. Turn the ignition switch to ON.
10. Loosen the throttle position sensor screw.
11. Adjust the throttle position sensor so that PCM terminal 3F voltage is within the specification. (Refer to page F1-40.)

Specification (closed throttle position)

Connector side terminal C Voltage (V)	PCM terminal 3F Voltage (V)
4.5—4.9	0.4—0.5
4.9—5.1	0.4—0.6
5.1—5.5	0.5—0.6

12. Tighten the throttle position sensor screw.

Tightening torque:

1.6—2.3 N·m { 16—24 kgf·cm , 14—20 in·lbf }

13. Fully open the throttle valve and verify that the voltage at PCM terminal 3F is within the specification.

Specification (wide open throttle)

Connector side terminal C Voltage (V)	PCM terminal 3F Voltage (V)
4.5—4.7	3.5—4.4
4.7—4.8	3.6—4.5
4.8—4.9	3.7—4.6
4.9—5.0	3.7—4.8
5.0—5.1	3.8—4.9
5.1—5.3	4.0—5.0
5.3—5.4	4.1—5.1
5.4—5.5	4.2—5.2

14. If not as specified, replace the throttle position sensor. (Refer to page F1-34.)
15. Adjust the throttle position sensor after installation.

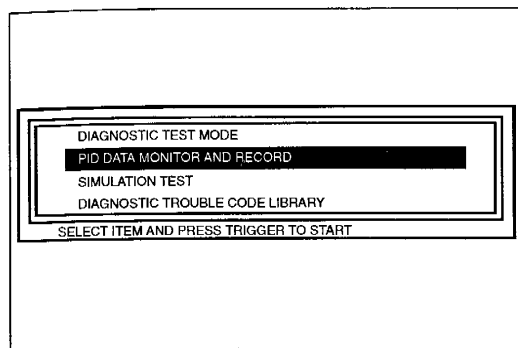
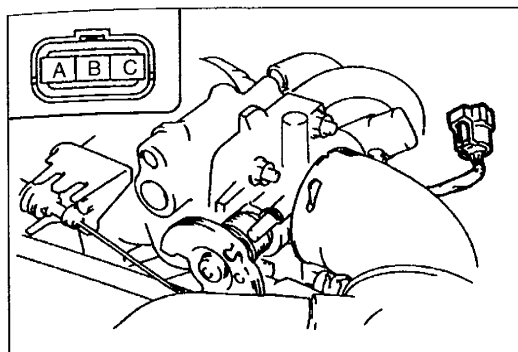

Using the NGS

1. Verify that the throttle valve is at the closed throttle position.
2. Disconnect the throttle position sensor connector.
3. Turn the ignition switch to ON.
4. Measure and record the voltage at the harness side connector terminal C by using the voltmeter.

Specification: 4.5—5.5 V

5. Connect the throttle position sensor connector.
6. Connect the **SSTs** (NGS) to the data link connector-2.
7. Select the PID/DATA MONITOR AND RECORD function.
8. Select the "TP V" and verify that the throttle valve is at the closed throttle position.
9. Loosen the throttle position sensor screw.
10. Adjust the throttle position sensor so that throttle position signal voltage is within the specification.

Specification (closed throttle position)

Connector side terminal C Voltage (V)	Throttle position signal Voltage (V)
4.5—4.9	0.4—0.5
4.9—5.1	0.4—0.6
5.1—5.5	0.5—0.6

11. Tighten the throttle position sensor screw.

Tightening torque:

1.6—2.3 N·m { 16—24 kgf·cm , 14—20 in·lbf }

12. Fully open the throttle valve and verify that the voltage is within the specification.

Specification (wide open throttle)

Connector side terminal C Voltage (V)	Throttle position signal Voltage (V)
4.5—4.7	3.5—4.4
4.7—4.8	3.6—4.5
4.8—4.9	3.7—4.6
4.9—5.0	3.7—4.8
5.0—5.1	3.8—4.9
5.1—5.3	4.0—5.0
5.3—5.4	4.1—5.1
5.4—5.5	4.2—5.2

13. If not as specified, replace the throttle position sensor. (Refer to page F1-34.)
14. Adjust the throttle position sensor after installation.

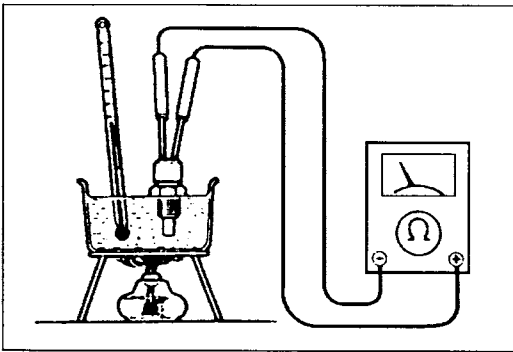

ENGINE COOLANT TEMPERATURE SENSOR

Inspection

1. Remove the engine coolant temperature sensor.
(Refer to page F1-34.)
2. Place the sensor in water with a thermometer, and heat the water gradually.
3. Measure the resistance of the sensor by using an ohmmeter.

Specification

Water temperature (°C { °F })	Resistance (kΩ)
20 { 68 }	2.2—2.7
80 { 176 }	0.3—0.4

4. If not as specified, replace the engine coolant temperature sensor.

INTAKE AIR TEMPERATURE SENSOR

Inspection

1. Remove the intake air temperature sensor.
(Refer to page F1-34.)
2. Place the sensor in water with a thermometer, and heat the water gradually.
3. Measure the resistance of the sensor by using an ohmmeter.

Specification

Water temperature (°C { °F })	Resistance (kΩ)
20 { 68 }	2.2—2.7
80 { 176 }	0.29—0.34

4. If not as specified, replace the intake air temperature sensor.

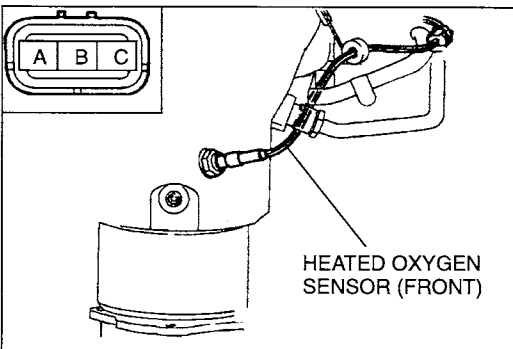
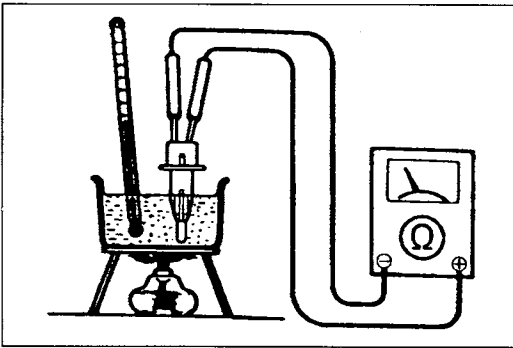

HEATED OXYGEN SENSOR

Inspection

Sensor

1. Warm up the engine to normal operating temperature.
2. Connect the **SSTs** (Engine Signal Monitor) to the PCM.
(Refer to page F1-36.)
3. Measure the PCM terminal 3C and 3D voltages.

Specification

Engine condition	PCM terminal 3C	PCM terminal 3D
Idle	0—1.0 V	0—1.0 V
Deceleration	0—0.5 V	0—1.0 V
Acceleration	0.5—1.0 V	0—1.0 V

4. If not as specified, inspect the following.
 - Harness and connector between heated oxygen sensor and PCM.
 - On-board diagnostic system (Refer to page F1-54.)
 - System inspection
 - Intake manifold vacuum (Refer to page F1-119.)
 - Fuel line pressure (Refer to page F1-120.)
5. If all the systems are OK, replace the heated oxygen sensor. (Refer to page F1-24.)

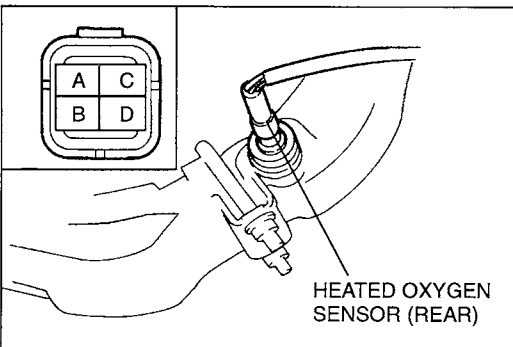

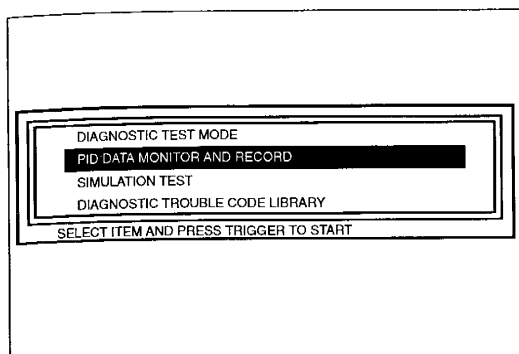

Using the NGS

1. Connect the **SSTs** (NGS) to the data link connector-2. (Refer to page F1-37.)
2. Select the PID/DATA MONITOR AND RECORD function.
3. Select "FHO2S", "RHO2S" on the NGS display. The NGS measures and shows the voltage.

Specification

Engine condition	FHO2S voltage (V)	RHO2S voltage (V)
Idle	0—1.0	0—1.0
Deceleration	0—0.5	0—1.0
Acceleration	0.5—1.0	0—1.0

4. If not as specified, inspect the following.
 - Harness and connector between heated oxygen sensor and PCM.
 - On-board diagnostic system (Refer to page F1-54.)
 - System inspection
 - Intake manifold vacuum (Refer to page F1-119.)
 - Fuel line pressure (Refer to page F1-120.)
5. If all the systems are OK, replace the heated oxygen sensor. (Refer to page F1-24.)

Heater

1. Disconnect the heated oxygen sensor connector.
2. Measure the resistance between heated oxygen sensor terminals B and C (Front) or D and C (Rear) by using an ohmmeter.

Specification: Approx. 6 Ω [20 °C { 68 °F }]

3. If not as specified, replace the heated oxygen sensor. (Refer to page F1-24.)

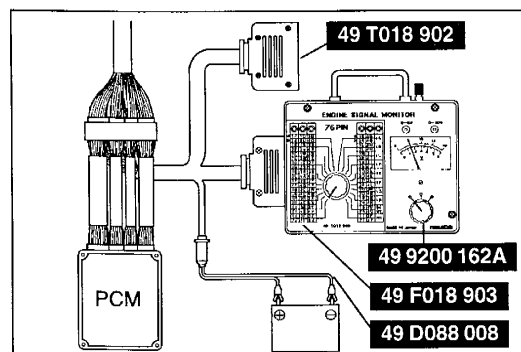
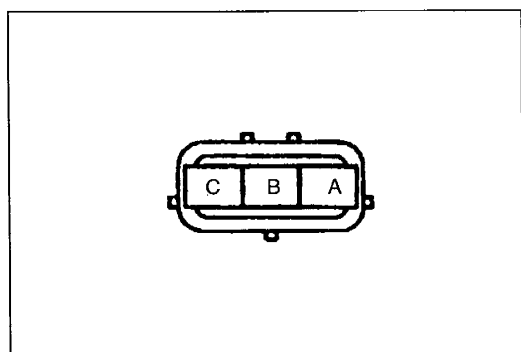

EGR VALVE POSITION SENSOR

Inspection

1. Disconnect the EGR valve position sensor connector.
2. Measure the resistance between terminals A and B by using an ohmmeter.

Specification: 2.7 k Ω

3. If not as specified, replace the EGR valve. (Refer to page F1-25.)
4. Connect the EGR valve position sensor connector.
5. Connect the **SSTs** (Engine Signal Monitor) to the PCM.
6. Disconnect the vacuum hose from the vacuum tube and install a vacuum pump to the valve.
7. Turn the ignition switch to ON.
8. Measure the voltage at the PCM terminal 3J.

Specification

Vacuum	PCM terminal 3J voltage (V)
0 kPa { 0 mmHg , 0 inHg }	Approx. 0.8
Approx. 17 kPa { 128 mmHg , 5.04 inHg }	Approx. 4.9

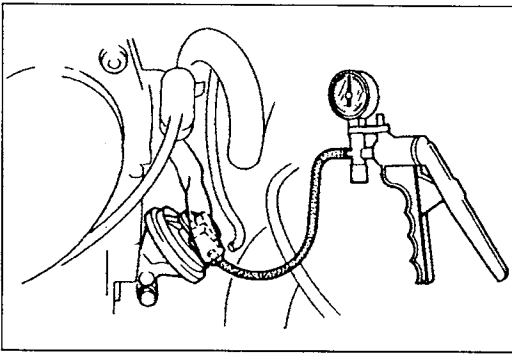

9. If not as specified, inspect the harness and connector between the EGR valve position sensor and the PCM terminal.
10. If these harness and connector are OK, replace the EGR valve. (Refer to page F1-25.)

Using the NGS

1. Disconnect the EGR valve position sensor connector.
2. Measure the resistance between terminals A and B of the connector by using an ohmmeter.

Specification: 2.7 kΩ

3. If not as specified, replace the EGR valve. (Refer to page F1-25.)
4. Connect the EGR valve position sensor connector.
5. Connect the air intake hose.
6. Connect the **SSTs** (NGS) to the data link connector-2. (Refer to page F1-37.)
7. Select the PID/DATA MONITOR AND RECORD function.
8. Disconnect the vacuum hose from the vacuum tube and install a vacuum pump to the valve.
9. Select the "EGRP V" on the NGS display. The NGS measures and shows the voltage.

Specification

Vacuum	EGR valve position signal voltage (V)
0 kPa { 0 mmHg , 0 inHg }	Approx. 0.8
Approx. 17 kPa { 128 mmHg , 5.04 inHg }	Approx. 4.9

10. If not as specified, inspect the harness and connector between the EGR valve position sensor and the PCM terminal.
11. If these harness and connector are OK, replace the EGR valve. (Refer to page F1-25.)

EGR BOOST SENSOR

Inspection

1. Connect the **SSTs** (Engine Signal Monitor) to the PCM. (Refer to page F1-36.)
2. Apply vacuum to the EGR boost sensor by using a vacuum pump. Measure the pressure at PCM terminal 3H.

Specification

Vacuum	PCM terminal 3H voltage (V)
86.3 kPa { 660 mmHg , 26.0 inHg }	Approx. 0.3
61.3 kPa { 460 mmHg , 18.1 inHg }	Approx. 1.6
6.3 kPa { 47.5 mmHg , 1.9 inHg }	Approx. 4.4

3. If not as specified, replace the EGR boost sensor. (Refer to page F1-34.)

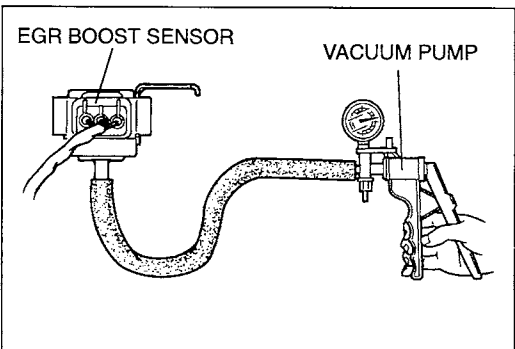
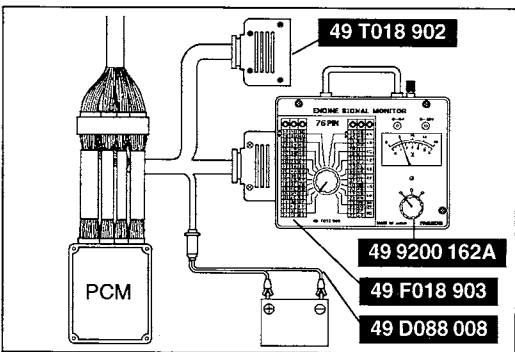
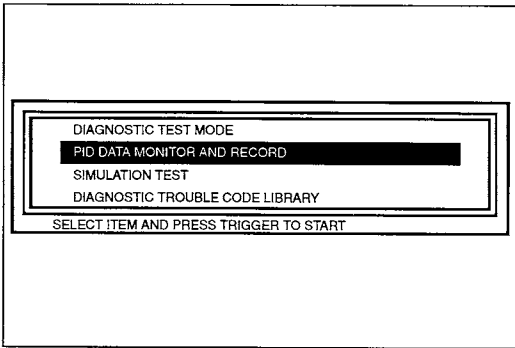
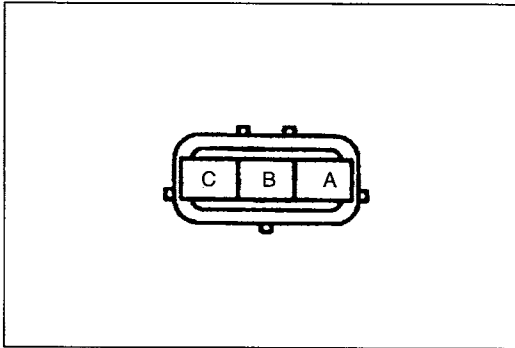

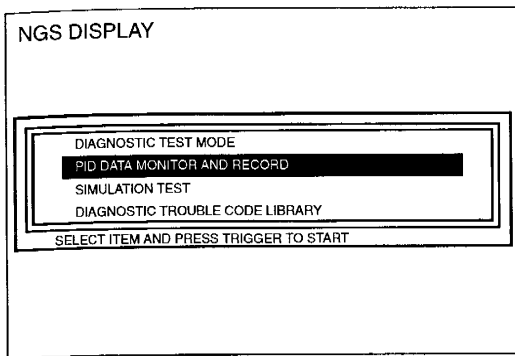

Using the NGS

1. Connect the **SSTs** (NGS) to the data link connector-2. (Refer to page F1-37.)
2. Select the PID/DATA MONITOR AND RECORD function.
3. Apply vacuum to the EGR boost sensor by using a vacuum pump.
4. Select "BARO V" on the NGS display. The NGS measures and shows the voltage.

Specification

Vacuum	Barometric pressure signal voltage (V)
86.3 kPa { 660 mmHg , 26.0 inHg }	Approx. 0.3
61.3 kPa { 460 mmHg , 18.1 inHg }	Approx. 1.6
6.3 kPa { 47.5 mmHg , 1.9 inHg }	Approx. 4.4

5. If not as specified, replace the EGR boost sensor. (Refer to page F1-34.)

FUEL TANK PRESSURE SENSOR

Inspection

1. Connect the **SSTs** (Engine Signal Monitor) to the PCM. (Refer to page F1-36.)
2. Apply vacuum to the fuel tank pressure sensor by using a vacuum pump. Measure the pressure at PCM terminal 3A.

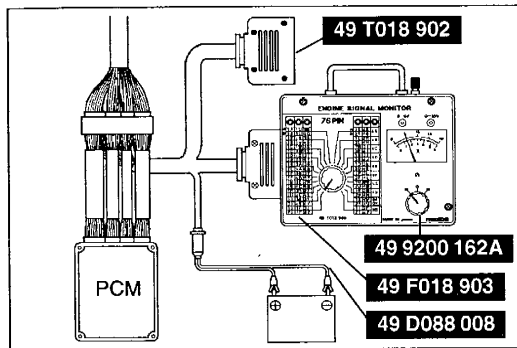

Specification

Vacuum	PCM terminal 3A voltage (V)
0 kPa { 0 mmHg , 0 inHg }	Approx. 2.5
6.7 kPa { 50 mmHg , 2.0 inHg }	Approx. 0.5

3. If not as specified, replace the fuel tank pressure sensor. (Refer to page F1-13.)

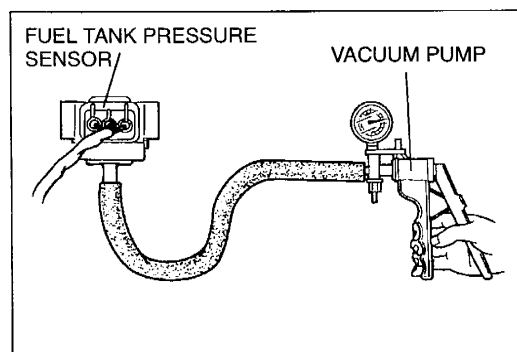

Using the NGS

1. Connect the **SSTs** (NGS) to the data link connector-2. (Refer to page F1-37.)
2. Select the PID/DATA MONITOR AND RECORD function.
3. Apply vacuum to the fuel tank pressure sensor by using a vacuum pump.
4. Select "FTP V" on the NGS display. The NGS measures and shows the voltage.

Specification

Vacuum	Fuel tank pressure signal voltage (V)
0 kPa { 0 mmHg , 0 inHg }	Approx. 2.5
6.7 kPa { 50 mmHg , 2.0 inHg }	Approx. 0.5

5. If not as specified, replace the fuel tank pressure sensor. (Refer to page F1-13.)

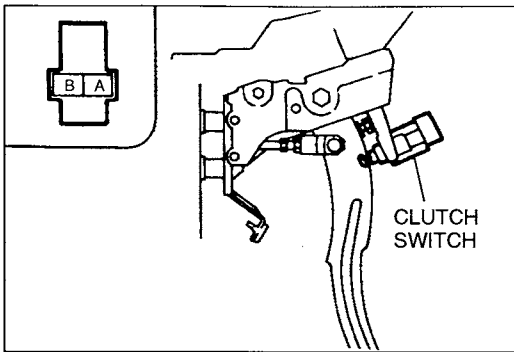

CLUTCH SWITCH

Inspection

1. Disconnect the clutch switch connector.
2. Check for continuity between terminals of the clutch switch by using an ohmmeter.

○—○: Continuity

Condition \ Terminal	A	B
Clutch pedal not depressed		
Clutch pedal depressed	○—○	○—○

3. If not as specified, replace the clutch switch.

Replacement

Install the clutch switch as shown in the figure.

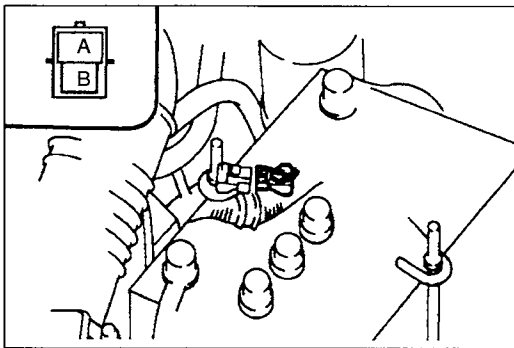
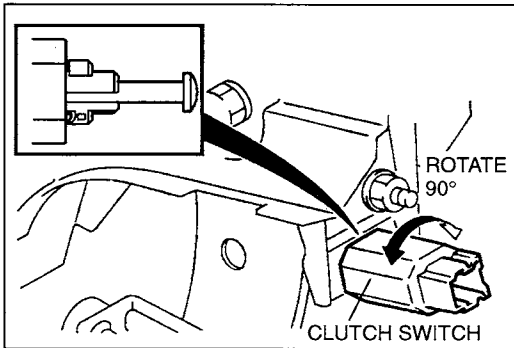

NEUTRAL SWITCH

Inspection

1. Disconnect the neutral switch connector.
2. Check for continuity between terminals of the neutral switch by using an ohmmeter.

○—○: Continuity

Condition \ Terminal	A	B
Neutral position	○—○	○—○
Others		

3. If not as specified, replace the neutral switch.
(Refer to page F1-34.)

POWER STEERING PRESSURE SWITCH

Inspection

1. Disconnect the power steering pressure switch connector.
2. Start the engine.
3. Check for the continuity between power steering pressure switch terminal and a ground by using an ohmmeter.

○—○: Continuity

Condition \ Terminal	A	Ground
Steering wheel not turned		
Steering wheel being turned	○—○	○—○

4. If not as specified, replace the power steering pressure switch. (Refer to page F1-34.)

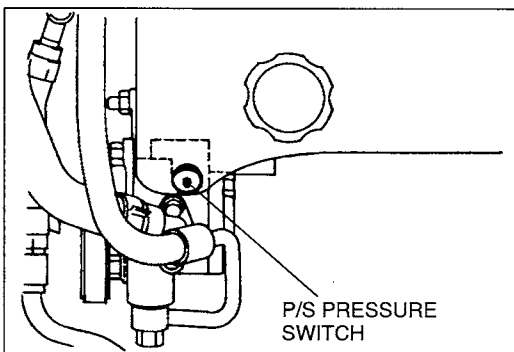

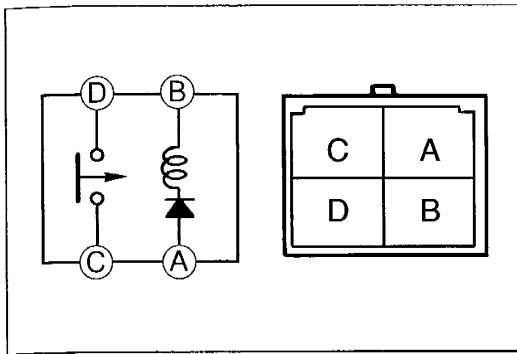

MAIN RELAY

Inspection

1. Remove the main relay. (Refer to page F1-34.)
2. Check the continuity between the relay terminals by using an ohmmeter.

○—○: Continuity B+: Battery positive voltage



Step \ Terminal	A	B	C	D
1	○—○	○—○		
2	Ground	B+	○—○	○—○

3. If not as specified, replace the main relay.

ON-BOARD DIAGNOSTIC SYSTEM

PREPARATION

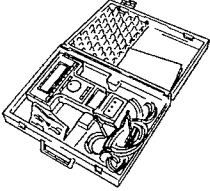
SST

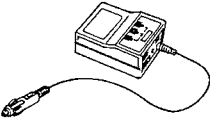
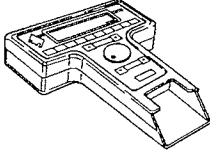
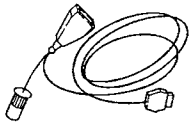
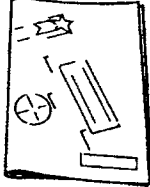
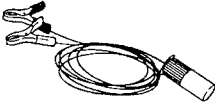
<p>49 T088 0A0 NGS set</p> 	<p>For diagnosis of PCM and input/output systems</p>	<p>49 T088 010B Program Card</p> 	<p>For diagnosis of PCM and input/output systems</p>
<p>49 T088 002 Vehicle Interface Module (Part of 49 T088 0A0)</p> 	<p>For diagnosis of PCM and input/output systems</p>	<p>49 T088 001 Control Unit (Part of 49 T088 0A0)</p> 	<p>For diagnosis of PCM and input/output systems</p>
<p>49 T088 004 NGS OBDII Adapter (Part of 49 T088 0A0)</p> 	<p>For diagnosis of PCM and input/output systems</p>	<p>49 T088 008A Instruction Manual</p> 	<p>For diagnosis of PCM and input/output systems</p>
<p>49 T088 006 Battery Hookup Adapter (Part of 49 T088 0A0)</p> 	<p>For diagnosis of PCM and input/output systems</p>	<p>—</p>	<p>—</p>

DIAGNOSTIC TROUBLE CODE NUMBER

Inspection

1. Connect the **SSTs** (NGS) to the data link connector-2. (Refer to page F1-37.)
2. Refer to the manufacturer-provided instruction manual for the NGS operation.
3. Select "DIAGNOSTIC TEST MODE" function and press trigger.
4. When "NO CODES RECEIVED/SYSTEM PASSED" is displayed, all systems monitored are judged OK.
5. When any of the diagnostic trouble codes is displayed, carry out troubleshooting according to the code. (Refer to page F1-55.)
6. If "LINK MONITOR ERROR" is displayed, check connection of the NGS.
7. After all problems have been repaired, carry out "After Repair Procedure." (Refer to below.)

After Repair Procedure



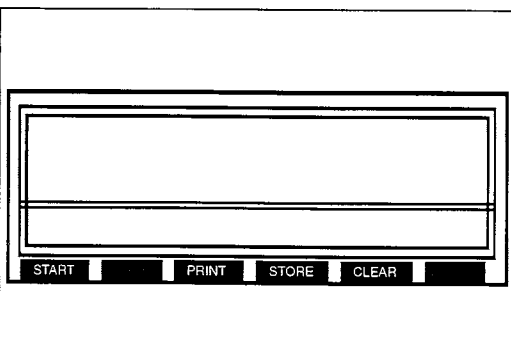
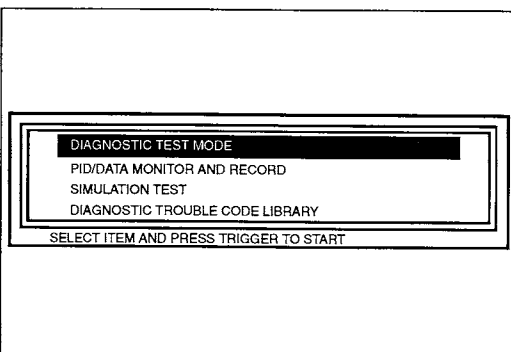

1. After repairs, connect the NGS to the data link connector-2.
2. Select "CLEAR" function and erase diagnostic trouble codes from the PCM memory.
3. Perform diagnostic trouble code inspection again and verify that no diagnostic trouble codes are displayed.







Diagnostic Trouble Code Numbers

DTC	Display on the NGS	Condition	Page
P0100	MAF/VAF—CIRCUIT MALFUNCTION	Mass air flow circuit malfunction	F1-57
P0110	IAT—CIRCUIT MALFUNCTION	Intake air temperature circuit malfunction	F1-58
P0115	ECT—CIRCUIT MALFUNCTION	Engine coolant temperature circuit malfunction	F1-59
P0120	TP—CIRCUIT MALFUNCTION	Throttle position circuit malfunction	F1-60
P0125	EXCESSIVE TIME TO ENTER CLOSED LOOP	Excessive time to enter closed loop fuel control	F1-61
P0130	O2S 11—CIRCUIT MALFUNCTION	O ₂ sensor circuit malfunction	F1-61
P0134	O2S 11—CIRCUIT NO ACTIVITY DETECTED	O ₂ sensor circuit no activity detected	F1-62
P0135	O2S 11—HEATER CIRCUIT MALFUNCTION	O ₂ sensor heater circuit malfunction	F1-63
P0140	O2S 12—CIRCUIT NO ACTIVITY DETECTED	O ₂ sensor circuit no activity detected	F1-64
P0170	BANK 1—FUEL TRIM MALFUNCTION	Fuel trim malfunction	F1-65
P0300	RANDOM MISFIRE DETECTED	Random misfire detected	F1-66
P0301	CYLINDER 1 MISFIRE DETECTED	Cylinder 1 misfire detected	F1-67
P0302	CYLINDER 2 MISFIRE DETECTED	Cylinder 2 misfire detected	F1-68
P0303	CYLINDER 3 MISFIRE DETECTED	Cylinder 3 misfire detected	F1-69
P0304	CYLINDER 4 MISFIRE DETECTED	Cylinder 4 misfire detected	F1-70
P0335	CRANKSHAFT POS SENSOR—CKT MALFUNCTION	Crankshaft position sensor circuit malfunction	F1-71
P0340	CAMSHAFT POS SENSOR—CKT MALFUNCTION	Camshaft position sensor circuit malfunction	F1-72
P0400	EGR—FLOW MALFUNCTION	Exhaust gas recirculation flow malfunction	F1-73
P0420	BANK 1 CAT EFFICIENCY BELOW LIMIT	Catalyst system efficiency below threshold	F1-73
P0440	EVAP SYSTEM—MALFUNCTION	Evaporative emission control system malfunction	F1-74

DTC	Display on the NGS	Condition	Page
P0443	EVAP SYSTEM—PURGE CTRL VALVE CKT MALF	Evaporative emission control system purge control valve circuit malfunction	F1-75
P0450	EVAP SYSTEM—PRESSURE SEN MALFUNCTION	Evaporative emission control system pressure sensor malfunction	F1-76
P0500	VEHICLE SPEED SENSOR—MALFUNCTION	Vehicle speed sensor malfunction	F1-77
P0505	IDLE CONTROL SYSTEM—MALFUNCTION	Idle control system malfunction	F1-78
P0703	TORQUE CONV/BRAKE SW—MALFUNCTION	Brake switch input malfunction	F1-79
P1000	MORE DRIVING NEEDED TO COMPLETE TEST	Check of all OBD-II system is not complete since last memory clear	F1-79
P1170	HO2S11—INVERSION	Heated oxygen sensor (Front) (Inversion)	F1-80
P1195	EGRBS—OPEN OR SHORT	EGR boost sensor open or short	F1-81
P1250	PRC—OPEN OR SHORT (Except California)	PRC solenoid valve open or short	F1-82
P1345	SGC SIGNAL—NO SGC SIGNAL (California)	No SGC signal	F1-83
P1402	EGRS—OPEN OR SHORT	EGR valve position sensor open or short	F1-84
P1449	CDCV—OPEN OR SHORT	Canister drain cut valve open or short	F1-85
P1455	FUEL TANK LEVEL SENSOR—OPEN OR SHORT	Fuel gauge sender unit circuit open or short	F1-86
P1485	EGR (VACUUM)—OPEN OR SHORT	EGR solenoid valve (vacuum) open or short	F1-87
P1486	EGR (VENT)—OPEN OR SHORT	EGR solenoid valve (vent) open or short	F1-88
P1487	EGRCHK SOL.—OPEN OR SHORT	EGR boost sensor solenoid valve open or short	F1-89
P1608	PCME (CPU)—MALFUNCTION	PCM (CPU) malfunction	F1-90
P1794	BAT—BAT OR CIRCUIT FAIL	Battery or circuit malfunction	F1-90
P1797	PNS—OPEN OR SHORT	P or N range or neutral/clutch switch open or short	F1-91

Diagnostic trouble code No. P0100	MAF/VAF—CIRCUIT MALFUNCTION		
Symptom	Input voltage from mass air flow sensor is below 0.6 V or above 4.9 V when ignition switch is turned on		
Possible cause	<ul style="list-style-type: none"> • Mass air flow sensor malfunction • Open or short circuit in wiring from main relay terminal D to mass air flow sensor terminal C • Open or short circuit in wiring from PCM terminal 3B to mass air flow sensor terminal B • Open circuit in wiring from PCM terminal 4A to mass air flow sensor terminal A 		
STEP	INSPECTION		ACTION
1	Does mass air flow sensor connector or PCM connector have poor connection?	Yes	Repair or replace connector
		No	Go to next step
2	Is PCM terminal 3B voltage OK?  page F1-39	Yes	Go to step 6
		No	Go to next step
3	Disconnect mass air flow sensor connector. Turn ignition switch to ON. Is there battery positive voltage at harness side connector terminal C?	Yes	Go to next step
		No	Check for open or short circuit in wiring harness. (Main relay terminal D — Mass air flow sensor terminal C)
4	Is there continuity between harness side connector terminal A and PCM terminal 4A?	Yes	Go to next step
		No	Repair or replace wiring harness
5	Is there continuity between harness side connector terminal B and PCM terminal 3B?	Yes	Replace mass air flow sensor  page F1-5
		No	Repair or replace wiring harness
6	Erase diagnostic trouble code from memory. Is same code No. present after rechecking?	Yes	Replace PCM  page F1-35
		No	Intermittent poor connection of harness or connector (Repair connector and/or harness)
 <p>HARNESS SIDE CONNECTOR (VIEW FROM BEHIND OF CONNECTOR)</p>			

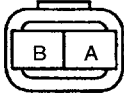



Diagnostic trouble code No. P0110		IAT—CIRCUIT MALFUNCTION	
Symptom		Input from intake air temperature sensor is below 0.1 V or above 4.8 V when ignition switch is turned on	
Possible cause		<ul style="list-style-type: none"> • Intake air temperature sensor malfunction • Open or short circuit in wiring from intake air temperature sensor terminal A to PCM terminal 3K • Open or short circuit in wiring from intake air temperature sensor terminal B to PCM terminal 3O 	
STEP	INSPECTION	ACTION	
1	Does intake air temperature sensor connector or PCM connector have poor connection?	Yes	Repair or replace connector
		No	Go to next step
2	Is PCM terminal 3K voltage OK?  page F1-40	Yes	Go to step 6
		No	Go to next step
3	Disconnect intake air temperature sensor connector. Turn ignition switch to ON. Is there 5 V at harness side connector terminal A?	Yes	Go to next step
		No	Check for open or short circuit in wiring harness. (PCM terminal 3K — Intake air temperature sensor terminal A)
4	Is there continuity between harness side connector terminal B and PCM terminal 3O?	Yes	Go to next step
		No	Repair or replace wiring harness
5	Is intake air temperature sensor OK?  page F1-48	Yes	Go to next step
		No	Replace intake air temperature sensor  page F1-34
6	Erase diagnostic trouble code from memory. Is same code No. present after rechecking?	Yes	Replace PCM  page F1-35
		No	Intermittent poor connection of harness of connector (Repair connector and/or harness)
 <p>HARNESS SIDE CONNECTOR (VIEW FROM BEHIND OF CONNECTOR)</p>			

Diagnostic trouble code No. P0115	ECT—CIRCUIT MALFUNCTION
Symptom	Input voltage from engine coolant temperature sensor is below 0.2 V or above 4.9 V when ignition switch is turned on
Possible cause	<ul style="list-style-type: none"> • Engine coolant temperature sensor malfunction • Open or short circuit in wiring from engine coolant temperature sensor terminal A to PCM terminal 3G • Open or short circuit in wiring from engine coolant temperature sensor terminal B to PCM terminal 3O

STEP	INSPECTION		ACTION
1	Does engine coolant temperature sensor or PCM connector have poor connection?	Yes	Repair or replace connector
		No	Go to next step
2	Is PCM terminal 3G voltage OK? ➡ page F1-40	Yes	Go to step 6
		No	Go to next step
3	Disconnect engine coolant temperature sensor connector. Turn ignition switch ON. Is there 5 V at harness side connector terminal A?	Yes	Go to next step
		No	Check for open or short circuit in wiring harness. (PCM terminal 3G — Engine coolant temperature sensor terminal A)
4	Is there continuity between harness side connector terminal B and PCM terminal 3O?	Yes	Go to next step
		No	Repair or replace wiring harness
5	Is engine coolant temperature sensor OK? ➡ page F1-48	Yes	Go to next step
		No	Replace engine coolant temperature sensor ➡ page F1-34
6	Erase diagnostic trouble code from memory. Is same code No. present after rechecking?	Yes	Replace PCM ➡ page F1-35
		No	Intermittent poor connection of harness or connector (Repair connector and/or harness)

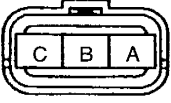

HARNESS SIDE CONNECTOR
(VIEW FROM BEHIND OF CONNECTOR)

Diagnostic trouble code No. P0120		TP—CIRCUIT MALFUNCTION	
Symptom		Input voltage from throttle position sensor is below 0.1 V or above 4.7 V when ignition switch is turned on	
Possible cause		<ul style="list-style-type: none"> • Throttle position sensor malfunction • Open or short circuit in wiring from throttle position sensor terminal A to PCM terminal 3O • Open or short circuit in wiring from throttle position sensor terminal B to PCM terminal 3F • Open or short circuit in wiring from throttle position sensor terminal C to PCM terminal 3I 	
STEP	INSPECTION	ACTION	
1	Does throttle position sensor connector or PCM connector have poor connection?	Yes	Repair or replace connector
		No	Go to next step
2	Is PCM terminal 3F voltage OK?  page F1-40	Yes	Go to next step
		No	Go to step 4
3	Is voltage increase linear according to throttle valve opening angle?	Yes	Go to step 7
		No	Replace throttle position sensor  page F1-34
4	Disconnect throttle position sensor connector. Turn ignition switch to ON. Is there 5 V harness side at connector terminal C?	Yes	Go to next step
		No	Check for open or short circuit in wiring harness. (PCM terminal 3I — Throttle position sensor terminal C)
5	Is there continuity between harness side connector terminal A and PCM terminal 3O?	Yes	Go to next step
		No	Repair or replace wiring harness
6	Is there continuity between harness side connector terminal C and PCM terminal 3I?	Yes	Replace throttle position sensor  page F1-34
		No	Repair or replace wiring harness
7	Erase diagnostic trouble code from memory. Is same code No. present after rechecking?	Yes	Replace PCM  page F1-35
		No	Intermittent poor connection of harness or connector (Repair connector and/or harness)
 <p>HARNESS SIDE CONNECTOR (VIEW FROM BEHIND OF CONNECTOR)</p>			

Diagnostic trouble code No. P0125		EXCESSIVE TIME TO ENTER CLOSED LOOP	
Symptom		Engine coolant temperature sensor signal does not rise normally because of engine coolant system malfunction	
Possible cause		<ul style="list-style-type: none"> • Engine coolant temperature sensor malfunction • Thermostat malfunction • Engine cooling fan system malfunction • Water pump malfunction • Engine coolant passage clogged or leaks • Engine coolant, level and protection 	
STEP	INSPECTION		ACTION
1	Is cooling fan control system OK? ☞ page F1-130	Yes	Go to next step
		No	Repair or replace cooling fan system
2	Is engine coolant temperature sensor resistance OK? ☞ page F1-48	Yes	Go to next step
		No	Replace engine coolant temperature sensor
3	Is cooling system OK? ☞ section E	Yes	Go to next step
		No	Repair or replace
4	Erase diagnostic trouble code from memory. Is some code No. present after *rechecking?	Yes	Replace PCM ☞ page F1-35
		No	Temporary system malfunction

* During normal driving

Diagnostic trouble code No. P0130		O2S 11—CIRCUIT MALFUNCTION	
Symptom		<ul style="list-style-type: none"> • Heated oxygen sensor (Front) deterioration • Leakage in exhaust system 	
STEP	INSPECTION		ACTION
1	Is heated oxygen sensor (Front) OK? ☞ page F1-48	Yes	Go to next step
		No	Repair or replace heated oxygen sensor (Front) ☞ page F1-34
2	Erase diagnostic trouble code from memory. Is same code No. present after *rechecking?	Yes	Replace PCM
		No	Intermittent poor connection of harness or connector (Repair connector and/or harness)

* During normal driving

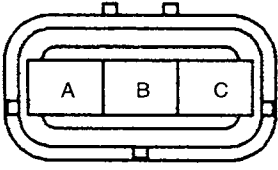
Diagnostic trouble code No. P0134		O2S 11—CIRCUIT NO ACTIVITY DETECTED	
Symptom		When heated oxygen sensor (Front) signal does not exceed 0.5 V after engine is started, or stays below 0.5 V for two minutes after engine has reached normal operating temperature and running at 1,500 rpm or over	
Possible cause		<ul style="list-style-type: none"> • Heated oxygen sensor (Front) malfunction • Open or short circuit in wiring from heated oxygen sensor (Front) terminal A to PCM terminal 3C • Intake-air system, fuel system, ignition system malfunction 	
STEP	INSPECTION	ACTION	
1	Does heated oxygen sensor (Front) connector or PCM connector have poor connection?	Yes	Repair or replace connector
		No	Go to next step
2	Is PCM terminal 3I voltage OK? 📖 page F1-40	Yes	Go to step 5
		No	Go to next step
3	Disconnect heated oxygen sensor (Front) connector. Is there continuity between harness side connector terminal A and PCM terminal 3C?	Yes	Go to next step
		No	Repair or replace wiring harness
4	Are following units OK? Fuel injector 📖 page F1-20 Pressure regulator 📖 page F1-21 Mass air flow sensor 📖 page F1-43 Engine coolant temperature sensor 📖 page F1-48 Spark plug 📖 section G Air suction (Air/Fuel ratio rich or lean)	Yes	Replace heated oxygen sensor (Front) and go to next step 📖 page F1-34
		No	Repair or replace
5	Erase diagnostic trouble code from memory. Is same code No. present after rechecking?	Yes	Replace PCM 📖 page F1-35
		No	Intermittent poor connection of harness or connector (Repair connector and/or harness)
 <p>HARNESS SIDE CONNECTOR (VIEW FROM BEHIND OF CONNECTOR)</p>			

Diagnostic trouble code No. P0135	O2S 11—HEATER CIRCUIT MALFUNCTION
Symptom	Open or short circuit is observed in heated oxygen sensor heater (Front) system when ignition switch is turned on
Possible cause	<ul style="list-style-type: none"> • Heated oxygen sensor heater (Front) malfunction • Open or short circuit in wiring from heated oxygen sensor (Front) terminal C to ignition switch • Open or short circuit in wiring from heated oxygen sensor (Front) terminal B to PCM terminal 3M

STEP	INSPECTION	ACTION	
1	Does heated oxygen sensor (Front) connector or PCM connector have poor connection?	Yes	Repair or replace connector
		No	Go to next step
2	Is PCM terminal 3M voltage OK? 🔍 page F1-40	Yes	Go to step 6
		No	Go to next step
3	Disconnect heated oxygen sensor (Front) connector and turn ignition switch to ON. Is there battery positive voltage at harness side connector terminal C?	Yes	Go to next step
		No	Check for open or short circuit in wiring harness. (Ignition switch — Heated oxygen sensor (Front) terminal C)
4	Is there continuity between harness side connector terminal B and PCM terminal 3M?	Yes	Go to next step
		No	Repair or replace wiring harness
5	Is there continuity between harness side connector terminals B and C?	Yes	Go to next step
		No	Replace heated oxygen sensor (Front) 🔍 page F1-34
6	Erase diagnostic trouble code from memory. Is same code No. present after rechecking?	Yes	Replace PCM 🔍 page F1-35
		No	Intermittent poor connection of harness or connector (Repair connector and/or harness)

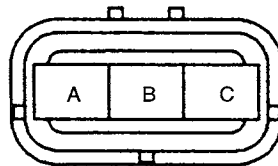







HARNESS SIDE CONNECTOR
(VIEW FROM BEHIND OF CONNECTOR)

Diagnostic trouble code No. P0140	O2S 12—CIRCUIT NO ACTIVITY DETECTED		
Symptom	When heated oxygen sensor (Rear) signal does not exceed 0.5 V after engine is started, or stays below 0.5 V for two minutes after engine has reached normal operating temperature and running at 1,500 rpm or over		
Possible cause	<ul style="list-style-type: none"> • Heated oxygen sensor (Rear) malfunction • Open or short circuit in wiring from (Rear) heated oxygen sensor (Rear) terminal A to PCM terminal 3D • Open circuit in wiring from heated oxygen sensor (Rear) terminal B to PCM terminal 3O. • Intake-air system, fuel system or ignition system malfunction 		
STEP	INSPECTION	ACTION	
1	Does heated oxygen sensor (Rear) connector or PCM connector have poor connection?	Yes	Repair or replace connector
		No	Go to next step
2	Is PCM terminal 3D voltage OK? ☞ page F1-40	Yes	Go to step 6
		No	Go to next step
3	Disconnect heated oxygen sensor (Rear) connector. Is there continuity between harness side connector terminal B and PCM terminal 3O?	Yes	Go to next step
		No	Repair or replace wiring harness
4	Is there continuity between harness side connector terminal A and PCM terminal 3D?	Yes	Go to next step
		No	Repair or replace wiring harness
5	Are following units OK? Fuel injector ☞ page F1-20 Pressure regulator ☞ page F1-21 Mass air flow sensor ☞ page F1-43 Engine coolant temperature sensor ☞ page F1-48 section G Spark plug Air suction (Air/Fuel ratio rich)	Yes	Replace heated oxygen sensor (Rear) ☞ page F1-34
		No	Repair or replace
6	Erase diagnostic trouble code from memory. Is same code No. present after rechecking?	Yes	Replace PCM ☞ page F1-35
		No	Intermittent poor connection of harness or connector (Repair connector and/or harness)
 <p>HARNESS SIDE CONNECTOR (VIEW FROM BEHIND OF CONNECTOR)</p>			

Diagnostic trouble code No. P0170		BANK 1—FUEL TRIM MALFUNCTION	
Symptom		Air/fuel ratio stays rich or lean longer than specified period because of system malfunction	
Possible cause		<ul style="list-style-type: none"> • Pressure regulator malfunction • Fuel injector malfunction • Fuel pump malfunction • Engine coolant temperature sensor malfunction • Mass air flow sensor malfunction • Heated oxygen sensor malfunction • Purge solenoid valve malfunction • Leakage in intake-air system • PCM malfunction • Open or short circuit in wiring between PCM terminals 4U, 4V, 4W, 4X to fuel injector • Intake air temperature sensor malfunction • EGR boost sensor malfunction • PCV valve malfunction 	
STEP	INSPECTION	ACTION	
1	Is there air leakage in intake-air system components? ☞ page F1-119	Yes	Repair or replace intake-air system
		No	Go to next step
2	Is fuel line pressure OK? ☞ page F1-120	Yes	Go to step 5
		No	Go to next step
3	Is fuel pump maximum pressure OK? ☞ page F1-19	Yes	Go to next step
		No	Repair or replace fuel pump ☞ page F1-13, 14
4	Is pressure regulator OK? ☞ page F1-21	Yes	Go to next step
		No	Replace pressure regulator ☞ page F1-16
5	Is fuel injector OK? ☞ page F1-20	Yes	Go to next step
		No	Replace fuel injector ☞ page F1-16
6	Is engine coolant temperature sensor OK? ☞ page F1-48	Yes	Go to next step
		No	Replace engine coolant temperature sensor ☞ page F1-34
7	Is mass air flow sensor OK? ☞ page F1-43	Yes	Go to next step
		No	Replace mass air flow sensor ☞ page F1-5
8	Is throttle position sensor OK? ☞ page F1-45	Yes	Go to next step
		No	Adjust throttle position sensor ☞ page F1-46
9	Is intake air temperature sensor OK? ☞ page F1-48	Yes	Go to next step
		No	Replace intake air temperatur sensor ☞ page F1-34
10	Is EGR boost sensor OK? ☞ page F1-50	Yes	Go to next step
		No	Replace EGR boost sensor ☞ page F1-34
11	Is purge solenoid valve OK? ☞ page F1-27	Yes	Go to next step
		No	Replace purge solenoid valve ☞ page F1-25
12	Is PCV valve OK? ☞ page F1-27	Yes	Go to next step
		No	Replace PCV valve ☞ page F1-25
13	Erase diagnostic trouble code from memory. Is same code No. present after *rechecking?	Yes	Replace PCM ☞ page F1-35
		No	Temporary system malfunction

* During idling

Diagnostic trouble code No. P0300		RANDOM MISFIRE DETECTED	
Symptom		PCM input signal from crankshaft position sensor signal is irregular	
Possible cause		<ul style="list-style-type: none"> • Ignition system malfunction • Low fuel • Low battery positive voltage • Fuel system malfunction • Insufficient compression • Crankshaft position sensor air gap incorrect • Exhaust gas recirculation system malfunction 	
STEP	INSPECTION	ACTION	
1	Is ignition system OK?  section G	Yes	Go to next step
		No	Repair or replace as necessary
2	Is crankshaft position sensor air gap correct?  page F1-44	Yes	Go to next step
		No	Repair or replace crankshaft position sensor  page F1-45
3	Is fuel system OK?  page F1-10	Yes	Go to next step
		No	Repair or replace as necessary
4	Is exhaust gas recirculation control system OK?  page F1-129	Yes	Go to next step
		No	Repair or replace as necessary
5	Is compression at all cylinders normal?  section B1	Yes	Go to next step
		No	Repair or replace as necessary
6	Erase diagnostic trouble code from memory. Is same code No. present after *rechecking?	Yes	Replace PCM  page F1-35
		No	Temporary system malfunction

* During normal driving

Diagnostic trouble code No. P0301		CYLINDER 1 MISFIRE DETECTED	
Symptom		PCM input signal from crankshaft position sensor signal for cylinder No.1 is irregular	
Possible cause		<ul style="list-style-type: none"> • Ignition system of cylinder No.1 malfunction • Low fuel • Low battery positive voltage • Fuel system malfunction • Insufficient compression in cylinder No.1 • Crankshaft position sensor air gap incorrect • Exhaust gas recirculation system malfunction 	
STEP	INSPECTION	ACTION	
1	Is ignition system of cylinder No.1 OK? ☞ section G	Yes	Go to next step
		No	Repair or replace as necessary
2	Is crankshaft position sensor air gap OK? ☞ page F1-44	Yes	Go to next step
		No	Repair or replace crankshaft position sensor ☞ page F1-45
3	Is fuel injector at cylinder No.1 OK? ☞ page F1-20	Yes	Go to next step
		No	Repair or replace fuel injector at cylinder No.1 ☞ page F1-16
4	Is fuel system OK? ☞ page F1-10	Yes	Go to next step
		No	Repair or replace as necessary
5	Is exhaust gas recirculation control system OK? ☞ page F1-129	Yes	Go to next step
		No	Repair or replace as necessary
6	Is compression at cylinder No.1 normal? ☞ section B1	Yes	Go to next step
		No	Repair or replace as necessary
7	Erase diagnostic trouble code from memory. Is same code No. present after *rechecking?	Yes	Replace PCM ☞ page F1-35
		No	Temporary system malfunction

* During normal driving

Diagnostic trouble code No. P0302		CYLINDER 2 MISFIRE DETECTED	
Symptom		PCM input signal from crankshaft position sensor signal for cylinder No.2 is irregular	
Possible cause		<ul style="list-style-type: none"> • Ignition system of cylinder No.2 malfunction • Low fuel • Low battery positive voltage • Fuel system malfunction • Insufficient compression in cylinder No.2 • Crankshaft position sensor air gap incorrect • Exhaust gas recirculation system malfunction 	
STEP	INSPECTION	ACTION	
1	Is ignition system of cylinder No.2 OK? ☞ section G	Yes	Go to next step
		No	Repair or replace as necessary
2	Is crankshaft position sensor air gap OK? ☞ page F1-44	Yes	Go to next step
		No	Repair or replace crankshaft position sensor ☞ page F1-45
3	Is fuel injector at cylinder No.2 OK? ☞ page F1-20	Yes	Go to next step
		No	Repair or replace fuel injector at cylinder No.2 ☞ page F1-16
4	Is fuel system OK? ☞ page F1-10	Yes	Go to next step
		No	Repair or replace as necessary
5	Is exhaust gas recirculation control system OK? ☞ page F1-129	Yes	Go to next step
		No	Repair or replace as necessary
6	Is compression at cylinder No.2 normal? ☞ section B1	Yes	Go to next step
		No	Repair or replace as necessary
7	Erase diagnostic trouble code from memory. Is same code No. present after *rechecking?	Yes	Replace PCM ☞ page F1-35
		No	Temporary system malfunction

* During normal driving





Diagnostic trouble code No. P0303	CYLINDER 3 MISFIRE DETECTED		
Symptom	PCM input signal from crankshaft position sensor signal for cylinder No.3 is irregular		
Possible cause	<ul style="list-style-type: none"> • Ignition system of cylinder No.3 malfunction • Low fuel • Low battery positive voltage • Fuel system malfunction • Insufficient compression in cylinder No.3 • Crankshaft position sensor air gap incorrect • Exhaust gas recirculation system malfunction 		
STEP	INSPECTION		ACTION
1	Is ignition system of cylinder No.3 OK? ☞ section G	Yes	Go to next step
		No	Repair or replace as necessary
2	Is crankshaft position sensor air gap OK? ☞ page F1-44	Yes	Go to next step
		No	Repair or replace crankshaft position sensor ☞ page F1-45
3	Is fuel injector at cylinder No.3 OK? ☞ page F1-20	Yes	Go to next step
		No	Repair or replace fuel injector at cylinder No.3 ☞ page F1-16
4	Is fuel system OK? ☞ page F1-10	Yes	Go to next step
		No	Repair or replace as necessary
5	Is exhaust gas recirculation control system OK? ☞ page F1-129	Yes	Go to next step
		No	Repair or replace as necessary
6	Is compression at cylinder No.3 normal? ☞ section B1	Yes	Go to next step
		No	Repair or replace as necessary
7	Erase diagnostic trouble code from memory. Is same code No. present after *rechecking?	Yes	Replace PCM ☞ page F1-35
		No	Temporary system malfunction

* During normal driving

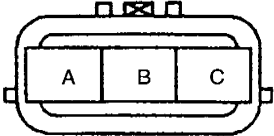
Diagnostic trouble code No. P0304		CYLINDER 4 MISFIRE DETECTED	
Symptom		PCM input signal from crankshaft position sensor signal for cylinder No.4 is irregular	
Possible cause		<ul style="list-style-type: none"> • Ignition system of cylinder No.4 malfunction • Low fuel • Low battery positive voltage • Fuel system malfunction • Insufficient compression in cylinder No.4 • Crankshaft position sensor air gap incorrect • Exhaust gas recirculation system malfunction 	
STEP	INSPECTION	ACTION	
1	Is ignition system of cylinder No.4 OK? ☞ section G	Yes	Go to next step
		No	Repair or replace as necessary
2	Is crankshaft position sensor air gap OK? ☞ page F1-44	Yes	Go to next step
		No	Repair or replace crankshaft position sensor ☞ page F1-45
3	Is fuel injector at cylinder No.4 OK? ☞ page F1-20	Yes	Go to next step
		No	Repair or replace fuel injector at cylinder No.4 ☞ page F1-16
4	Is fuel system OK? ☞ page F1-10	Yes	Go to next step
		No	Repair or replace as necessary
5	Is exhaust gas recirculation control system OK? ☞ page F1-129	Yes	Go to next step
		No	Repair or replace as necessary
6	Is compression at cylinder No.4 normal? ☞ section B1	Yes	Go to next step
		No	Repair or replace as necessary
7	Erase diagnostic trouble code from memory. Is same code No. present after *rechecking?	Yes	Replace PCM ☞ page F1-35
		No	Temporary system malfunction

* During normal driving



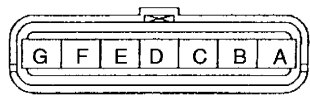



Diagnostic trouble code No. P0335		CRANKSHAFT POS SENSOR—CKT MALFUNCTION	
Symptom		No NE signal input from crankshaft position sensor for 1.5 seconds while engine running	
Possible cause		<ul style="list-style-type: none"> • Crankshaft position sensor malfunction • Open or short circuit in wiring from PCM terminal 4E to crankshaft position sensor terminal B • Open or short circuit in wiring from PCM terminal 4H to crankshaft position sensor terminal A 	
STEP	INSPECTION	ACTION	
1	Does crankshaft position sensor connector or PCM connector have poor connection?	Yes	Repair or replace connector
		No	Go to next step
2	Disconnect crankshaft position sensor connector. Is there continuity between harness side connector terminal B and PCM terminal 4E? Is there continuity between harness side connector terminal A and PCM terminal 4H?	Yes	Go to next step
		No	Repair or replace wiring harness
3	Is crankshaft position sensor air gap OK? ☞ page F1-44	Yes	Go to next step
		No	Replace crankshaft position sensor or crankshaft pulley ☞ page F1-45 ☞ section B1
4	Is crankshaft position sensor OK? ☞ page F1-44	Yes	Go to next step
		No	Replace crankshaft position sensor ☞ page F1-45
5	Erase diagnostic trouble code from memory. Is same code No. present after rechecking?	Yes	Replace PCM ☞ page F1-35
		No	Intermittent poor connection of harness or connector (Repair connector and/or harness)
 <p>HARNESS SIDE CONNECTOR (VIEW FROM BEHIND OF CONNECTOR)</p>			

Diagnostic trouble code No. P0340		CAMSHAFT POS SENSOR—CKT MALFUNCTION	
Symptom		No SGT signal input from camshaft position sensor for 4.2 seconds while engine running	
Possible cause		<ul style="list-style-type: none"> • Camshaft position sensor malfunction • Open or short circuit in wiring from PCM terminal 4F to distributor terminal C • Open or short circuit in wiring from PCM terminal 4A to distributor terminal A 	
STEP	INSPECTION	ACTION	
1	Does distributor connector or PCM connector have poor connection?	Yes	Repair or replace connector
		No	Go to next step
2	Disconnect distributor connector. Is there continuity between harness side connector terminal C and PCM terminal 4F? Is there continuity between harness side connector terminal A and PCM terminal 4A?	Yes	Go to next step
		No	Repair or replace wiring harness
3	Is camshaft position sensor OK?  page F1-44	Yes	Go to next step
		No	Replace distributor  section G
4	Erase diagnostic trouble code from memory. Is same code No. present after rechecking?	Yes	Replace PCM  page F1-35
		No	Intermittent poor connection of harness or connector (Repair connector and/or harness)
  <p>CALIFORNIA EXCEPT CALIFORNIA</p> <p>HARNESS SIDE CONNECTOR (VIEW FROM BEHIND OF CONNECTOR)</p>			



Diagnostic trouble code No. P0400	EGR—FLOW MALFUNCTION		
Symptom	Exhaust gas recirculation system does not function normally because of electrical or mechanical trouble		
Possible cause	<ul style="list-style-type: none"> • EGR valve malfunction • EGR boost sensor malfunction • EGR boost sensor solenoid valve malfunction • EGR valve position sensor malfunction • EGR solenoid valve (vacuum, vent) malfunction • Clogs or leakage in piping connecting following units EGR boost sensor, EGR boost sensor solenoid valve and intake manifold Air cleaner housing, EGR solenoid valve (vent) and EGR valve Intake manifold, EGR solenoid valve (vacuum) and EGR valve Warm up three way catalytic converter 		
STEP	INSPECTION		ACTION
1	Is diagnostic trouble code for EGR solenoid valve (vacuum, vent), EGR boost sensor solenoid valve or EGR boost sensor displayed?	Yes	Carry out inspection as required according to diagnostic trouble code
		No	Go to next step
2	Is EGR valve position sensor OK? ☞ page F1-49	Yes	Go to next step
		No	Repair or replace EGR valve ☞ page F1-25
3	Check each hose for damage. Are they OK? • Intake manifold—EGR solenoid valve (vent) • EGR solenoid valve (vent)—EGR solenoid valve (vacuum) • EGR solenoid valve (vacuum)-EGR valve	Yes	Go to next step
		No	Repair or replace as necessary
4	EGR boost sensor OK? ☞ page F1-50	Yes	Go to next step
		No	Replace EGR boost sensor ☞ page F1-34
5	Check each hose for damage. Are they OK? • EGR passage—EGR boost sensor solenoid valve • EGR boost sensor—EGR boost sensor solenoid valve	Yes	Go to next step
		No	Repair or replace as necessary
6	Erase diagnostic trouble code from memory. Is same code No. present after *rechecking?	Yes	Replace PCM ☞ page F1-35
		No	Temporary system malfunction

* During driving when coolant temperature is over 55 ° C { 131 ° F } and engine speed is over 1,000 rpm (10 km/h { 6.2 mph })

Diagnostic trouble code No. P0420	BANK 1 CAT EFFICIENCY BELOW LIMIT		
Symptom	<ul style="list-style-type: none"> • Warm up three way catalytic converter deterioration • Leakage in exhaust system 		
STEP	INSPECTION		ACTION
1	Is heated oxygen sensor (Rear) OK? ☞ page F1-48	Yes	Replace warm up three way catalytic converter ☞ page F1-30
		No	Replace heated oxygen sensor (Rear) ☞ page F1-34



Diagnostic trouble code No. P0440		EVAP SYSTEM—MALFUNCTION	
Symptom		Evaporative emission control system does not function normally because of mechanical trouble	
Possible cause		<ul style="list-style-type: none"> • Purge solenoid valve • Charcoal canister malfunction • Check valve malfunction • Fuel vapor valve malfunction • Clogs or leakage in piping connecting following units Intake manifold and purge solenoid valve Purge solenoid valve and charcoal canister Charcoal canister, check valve, and fuel vapor valve 	
STEP	INSPECTION		ACTION
1	Is PCM terminal 4T voltage OK?  page F1-42	Yes	Go to next step
		No	Inspect purge solenoid valve  page F1-27
2	Are evaporative emission control system-related hose free of clogs and leakage?	Yes	Go to next step
		No	Repair or replace as necessary
3	Is charcoal canister OK?  page F1-26	Yes	Go to next step
		No	Repair or replace as necessary
4	Is check valve OK?  page F1-26	Yes	Go to next step
		No	Repair or replace as necessary
5	Is rollover valve OK?  page F1-25	Yes	Go to next step
		No	Repair or replace as necessary
6	Erase diagnostic trouble code from memory. Is same code No. present after *rechecking?	Yes	Replace PCM  page F1-35
		No	Temporary system malfunction

* During driving after engine warm-up

Diagnostic trouble code No. P0443	EVAP SYSTEM—PURGE CTRL VALVE CKT—MALF		
Symptom	Open or short circuit is observed in purge solenoid valve system when ignition switch is turned on		
Possible cause	<ul style="list-style-type: none"> • Purge solenoid valve malfunction • Open or short circuit in wiring from purge solenoid valve terminal A to main relay terminal D • Open or short circuit in wiring from purge solenoid valve terminal B to PCM terminal 4T 		
STEP	INSPECTION		ACTION
1	Does purge solenoid valve connector or PCM connector have poor connection?	Yes	Repair or replace connector
		No	Go to next step
2	Is PCM terminal 4T voltage OK?  page F1-42	Yes	Go to step 6
		No	Go to next step
3	Disconnect purge solenoid valve connector. Turn ignition switch to ON. Is there battery positive voltage at harness side connector terminal A?	Yes	Go to next step
		No	Check for open or short circuit in wiring harness. (Main relay terminal D — Purge solenoid valve terminal A)
4	Is there continuity between harness side connector terminal B and PCM terminal 4T?	Yes	Go to next step
		No	Repair or replace wiring harness
5	Is there continuity between purge solenoid valve connector terminals A and B?	Yes	Go to next step
		No	Replace purge solenoid valve
6	Erase diagnostic trouble code from memory. Is same code No. present after rechecking?	Yes	Replace PCM  page F1-35
		No	Intermittent poor connection of harness or connector (Repair connector and/or harness)

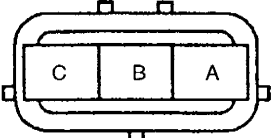

HARNESS SIDE CONNECTOR
(VIEW FROM BEHIND OF CONNECTOR)

Diagnostic trouble code No. P0450		EVAP SYSTEM—PRESSURE SEN MALFUNCTION	
Symptom		Input voltage from fuel tank pressure sensor is below 0.1 V or above 4.8 V when ignition switch is turned on	
Possible cause		<ul style="list-style-type: none"> • Fuel tank pressure sensor malfunction • Open or short circuit in wiring from PCM terminal 3I to fuel tank pressure sensor terminal C • Open or short circuit in wiring from PCM terminal 3A to fuel tank pressure sensor terminal B • Open circuit in wiring from PCM terminal 3O to fuel tank pressure sensor terminal A 	
STEP	INSPECTION		ACTION
1	Does fuel tank pressure sensor connector or PCM connector have poor connection?	Yes	Repair or replace connector
		No	Go to next step
2	Is PCM terminal 3A voltage OK?  page F1-40	Yes	Go to step 6
		No	Go to next step
3	Are fuel tank pressure sensor and connecting hose free of freezing, breaking, and clogs?	Yes	Repair or replace
		No	Go to next step
4	Disconnect fuel tank pressure sensor connector. Turn ignition switch to ON. Is there 5 V at harness side connector terminal A?	Yes	Go to next step
		No	Check for open or short circuit in wiring harness. (PCM terminal 3I — Fuel tank pressure sensor terminal C)
5	Is fuel tank pressure sensor OK?  page F1-51	Yes	Replace fuel tank pressure sensor
		No	Repair or replace wiring harness
6	Erase diagnostic trouble code from memory. Is same code present after rechecking?	Yes	Replace PCM  page F1-35
		No	Intermittent poor connector of harness or connector (Repair connector and/or harness)
 <p>HARNESS SIDE CONNECTOR (VIEW FROM BEHIND OF CONNECTOR)</p>			

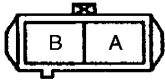

Diagnostic trouble code No. P0500		VEHICLE SPEED SENSOR—MALFUNCTION	
Symptom		No vehicle speed sensor signal input from vehicle speed sensor while driving	
Possible cause		<ul style="list-style-type: none"> • Speedometer sensor malfunction • Open or short circuit in wiring from ignition switch to speedometer sensor • Open or short circuit in wiring from speedometer sensor to GND • Open or short circuit in wiring from speedometer sensor to vehicle speed sensor • Open or short circuit in wiring from vehicle speed sensor to PCM terminal 1M 	
STEP	INSPECTION	ACTION	
1	Does vehicle speed sensor connector or PCM connector have poor connection?	Yes	Repair or replace connector
		No	Go to next step
2	Is PCM terminal 1M voltage OK? ☞ page F1-39	Yes	Go to step 5
		No	Go to next step
3	Is there continuity between vehicle speed sensor terminal and PCM terminal 1M?	Yes	Go to next step
		No	Repair or replace wiring harness
4	Is there continuity between vehicle speed sensor and speedometer sensor terminals? ☞ section T	Yes	Go to next step
		No	Repair or replace speedometer sensor and wiring harness ☞ section T
5	Erase diagnostic trouble code from memory. Is same code No. present after rechecking?	Yes	Replace PCM ☞ page F1-35
		No	Intermittent poor connection of harness or connector (Repair connector and/or harness)



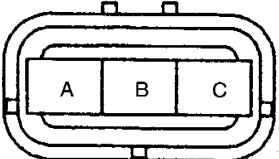

Diagnostic trouble code No. P0505		IDLE CONTROL SYSTEM—MALFUNCTION	
Symptom		<ul style="list-style-type: none"> • Mechanical trouble is observed in idle air control system • Open or short circuit is observed in idle air control system when ignition switch is turned on 	
Possible cause		<ul style="list-style-type: none"> • Idle air control valve malfunction • Leakage in intake-air system • Open or short circuit in wiring from idle air control valve terminal A to main relay terminal D • Open or short circuit in wiring from idle air control valve terminal B to PCM terminal 4Q 	
STEP	INSPECTION	ACTION	
1	Does idle air control valve connector or PCM connector have poor connection?	Yes	Repair or replace connector
		No	Go to next step
2	Is PCM terminal 4Q voltage OK? 📖 page F1-41	Yes	Go to step 6
		No	Go to next step
3	Disconnect idle air control valve connector. Turn ignition switch to ON. Is there battery positive voltage at harness side connector terminal A?	Yes	Go to next step
		No	Check for open or short circuit in wiring harness. (Main relay terminal D — Idle air control valve terminal A)
4	Is there continuity between harness side connector terminal B and PCM terminal 4Q?	Yes	Go to next step
		No	Repair or replace wiring harness
5	Is there continuity between idle air control valve connector terminals A and B?	Yes	Go to next step
		No	Replace BAC valve 📖 page F1-7
6	Erase diagnostic trouble code from memory. Is same code No. present after rechecking?	Yes	Replace PCM 📖 page F1-35
		No	Intermittent poor connection of harness or connector (Repair connector and/or harness)
 <p>HARNESS SIDE CONNECTOR (VIEW FROM BEHIND OF CONNECTOR)</p>			



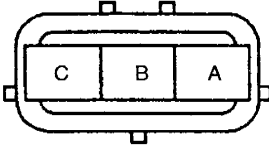

Diagnostic trouble code No. P0703		TORQUE CONV/BRAKE SW—MALFUNCTION	
Symptom		No signal input from brake switch to PCM when brake pedal is kept depressed for more than 33 seconds, or signal input when brake pedal is not depressed	
Possible cause		<ul style="list-style-type: none"> • Brake switch malfunction • Open or short circuit in wiring from PCM terminal 1Q to brake switch terminal • Open or short circuit in wiring from brake switch terminal to battery terminal 	
STEP	INSPECTION	ACTION	
1	Does brake switch connector or PCM connector have poor connection?	Yes	Repair or replace
		No	Go to next step
2	Is PCM terminal 1Q voltage OK? ☞ page F1-39	Yes	Go to step 4
		No	Go to next step
3	Is there continuity between brake switch terminal and PCM terminal 1Q?	Yes	Check for open or short circuit in wiring harness. (Battery — Brake switch) Check brake switch. ☞ section P
		No	Repair or replace wiring harness
4	Erase diagnostic trouble code from memory. Is same code No. present after rechecking?	Yes	Replace PCM ☞ page F1-35
		No	Intermittent poor connection of harness or connector (Repair connector and/or harness)

Diagnostic trouble code No. P1000	MORE DRIVING NEEDED TO COMPLETE TEST	
Possible cause	Following diagnostic trouble code detection conditions not satisfied	
	Diagnosed circuit	Code No.
	Excessive time to enter closed loop fuel control	P0125
	O ₂ sensor circuit malfunction	P0130
	O ₂ sensor heater circuit malfunction	P0135
	Fuel trim malfunction	P0170
	Random misfire detected Cylinder 1 misfire detected Cylinder 2 misfire detected Cylinder 3 misfire detected Cylinder 4 misfire detected	P0300, P0301 P0302, P0303 P0304
	Exhaust gas recirculation flow malfunction	P0400
	Catalyst system efficiency below threshold	P0420
	Evaporative emission control system malfunction	P0440
Note	<ul style="list-style-type: none"> • DTC No.P1000 will be deleted while the MIL is illuminated. 	

Diagnostic trouble code No. P1170		HO2S 11—INVERSION	
Symptom		Heated oxygen sensor (Front) signal remains unchanged for more than 20 seconds after engine is in feedback zone	
Possible cause		<ul style="list-style-type: none"> • Heated oxygen sensor (Front) malfunction • Open or short circuit in wiring from heated oxygen sensor (Front) terminal A to PCM terminal 3C • Intake-air system, fuel system, ignition system malfunction 	
STEP	INSPECTION	ACTION	
1	Does heated oxygen sensor (Front) connector or PCM connector have poor connection?	Yes	Repair or replace connector
		No	Go to next step
2	Is PCM terminal 3C voltage OK? ☞ page F1-40	Yes	Go to step 5
		No	Go to next step
3	Disconnect heated oxygen sensor (Front) connector. Is there continuity between harness side connector terminal A and PCM terminal 3C?	Yes	Go to next step
		No	Repair or replace wiring harness
4	Are following units OK? Fuel injector ☞ page F1-20 Pressure regulator ☞ page F1-21 Mass air flow sensor ☞ page F1-43 Engine coolant temperature sensor ☞ page F1-48 Spark plug ☞ section G Air suction (Air/Fuel ratio rich or lean)	Yes	Replace heated oxygen sensor (Front) ☞ page F1-34
		No	Repair or replace
5	Erase diagnostic trouble code from memory. Is same code No. present after rechecking?	Yes	Replace PCM ☞ page F1-35
		No	Intermittent poor connection of harness or connector (Repair connector and/or harness)
 <p>HARNESS SIDE CONNECTOR (VIEW FROM BEHIND OF CONNECTOR)</p>			

Diagnostic trouble code No. P1195		EGRBS—OPEN OR SHORT	
Symptom		Input voltage from EGR boost sensor is below 0.2 V or above 4.9 V when ignition switch is turned on	
Possible cause		<ul style="list-style-type: none"> • EGR boost sensor malfunction • Open or short circuit in wiring from PCM terminal 3H to EGR boost sensor terminal B • Open or short circuit in wiring from PCM terminal 3I to EGR boost sensor terminal C • Open circuit in wiring from PCM terminal 3O to EGR boost sensor terminal A 	
STEP	INSPECTION		ACTION
1	Does EGR boost sensor connector or PCM connector have poor connection?	Yes	Repair or replace connector
		No	Go to next step
2	Is PCM terminal 3H voltage OK?  page F1-40	Yes	Go to step 5
		No	Go to next step
3	Disconnect EGR boost sensor connector. Turn ignition switch to ON. Is there 5V at harness side connector terminal C?	Yes	Go to next step
		No	Check for open or short circuit in wiring harness. (PCM terminal 3I — EGR boost sensor terminal C)
4	Is there continuity between connector terminal A and PCM terminal 3O?	Yes	Replace EGR boost sensor
		No	Repair or replace wiring harness.
5	Erase diagnostic trouble code from memory. Is same code present after rechecking?	Yes	Replace PCM  page F1-35
		No	Intermittent poor connection of harness or connector (Repair connector and/or harness.)
 <p>HARNESS SIDE CONNECTOR (VIEW FROM BEHIND OF CONNECTOR)</p>			

Diagnostic trouble code No. P1250		PRC—OPEN OR SHORT	
Symptom		Open or short circuit is observed in PRC solenoid valve system when ignition switch is turned on	
Possible cause		<ul style="list-style-type: none"> • PRC solenoid valve malfunction • Open or short circuit in wiring from PRC solenoid valve terminal A to main relay terminal D • Open or short circuit in wiring from PRC solenoid valve terminal B to PCM terminal 4J 	
STEP	INSPECTION	ACTION	
1	Does PRC solenoid valve connector or PCM connector have poor connection?	Yes	Repair or replace connector
		No	Go to next step
2	Is PCM terminal 4J voltage OK?  page F1-41	Yes	Go to step 6
		No	Go to next step
3	Disconnect PRC solenoid valve connector. Turn ignition switch ON. Is there battery positive voltage at harness side connector terminal A?	Yes	Go to next step
		No	Check for open or short circuit in wiring harness. (Main relay terminal D — PRC solenoid valve terminal A)
4	Is there continuity between harness side connector terminal B and PCM terminal 4J?	Yes	Go to next step
		No	Repair or replace wiring harness
5	Is there continuity between PRC solenoid valve terminals A and B?	Yes	Go to next step
		No	Replace PRC solenoid valve  page F1-18
6	Erase diagnostic trouble code from memory. Is same code No. present after rechecking?	Yes	Replace PCM  page F1-35
		No	Intermittent poor connection of harness or connector (Repair connector and/or harness)
 <p>HARNESS SIDE CONNECTOR (VIEW FROM BEHIND OF CONNECTOR)</p>			

Diagnostic trouble code No. P1345		SGC SIGNAL—NO SGC SIGNAL	
Symptom		No SGC signal input from camshaft position sensor while engine rotates five cycles	
Possible cause		<ul style="list-style-type: none"> • Camshaft position sensor malfunction • Open or short circuit in wiring from PCM terminal 4A to distributor terminal A • Open or short circuit in wiring from PCM terminal 4G to distributor terminal D 	
STEP	INSPECTION		ACTION
1	Does camshaft position sensor connector or PCM connector have poor connection?	Yes	Repair or replace connector
		No	Go to next step
2	Disconnect distributor connector. Turn ignition switch to ON. Is there battery positive voltage at harness side connector terminal B?	Yes	Go to next step
		No	Check for open or short circuit in wiring harness. (Main relay terminal D — Distributor terminal B)
3	Is there continuity between harness side connector terminal C and PCM terminal 4G?	Yes	Go to next step
		No	Repair or replace wiring harness
4	Is PCM terminal 4G voltage OK?  page F1-41	Yes	Go to step 6
		No	Go to next step
5	Is camshaft position sensor OK?  page F1-44	Yes	Go to next step
		No	Replace distributor  section G
6	Erase diagnostic trouble code from memory. Is same code No. present after rechecking.	Yes	Replace PCM  page F1-35
		No	Intermittent poor connection of harness or connector (Repair connector and/or harness)
 <p>HARNESS SIDE CONNECTOR (VIEW FROM BEHIND OF CONNECTOR)</p>			

Diagnostic trouble code No. P1402	EGRS—OPEN OR SHORT
Symptom	Input voltage from EGR valve position sensor is below 0.2 V or above 4.8 V when ignition switch is turned on
Possible cause	<ul style="list-style-type: none"> • EGR valve position sensor malfunction • Open or short circuit in wiring from EGR valve position sensor terminal B to PCM terminal 3I • Open or short circuit in wiring from EGR valve position sensor terminal C to PCM terminal 3J • Open or short circuit in wiring from EGR valve position sensor terminal A to PCM terminal 3O

STEP	INSPECTION		ACTION
1	Does EGR valve position sensor connector or PCM connector have poor connection?	Yes	Repair or replace connector
		No	Go to next step
2	Is PCM terminal 3J voltage OK? ☞ page F1-40	Yes	Go to step 7
		No	Go to next step
3	Disconnect EGR valve position sensor connector. Turn ignition switch ON. Is there 5 V at harness side connector terminal B?	Yes	Go to next step
		No	Check for open or short circuit in wiring harness. (PCM terminal 3I — EGR valve position sensor terminal B)
4	Is there continuity between harness side connector terminal C and PCM terminal 3J?	Yes	Go to next step
		No	Repair or replace wiring harness
5	Is there continuity between harness side connector terminal A and PCM terminal 3O?	Yes	Go to next step
		No	Repair or replace wiring harness
6	Is resistance of EGR valve position sensor OK? ☞ page F1-49	Yes	Go to next step
		No	Replace EGR valve ☞ page F1-25
7	Erase diagnostic trouble code from memory. Is same code No. present after rechecking?	Yes	Replace PCM ☞ page F1-35
		No	Intermittent poor connection of harness or connector (Repair connector and/or harness)



HARNESS SIDE CONNECTOR
(VIEW FROM BEHIND OF CONNECTOR)

Diagnostic trouble code No. P1449	CDCV—OPEN OR SHORT
Symptom	Open or short circuit is observed in canister drain cut valve or tank pressure control valve system when ignition switch is turned on
Possible cause	<ul style="list-style-type: none"> • Canister drain cut valve malfunction • Tank pressure control valve malfunction • Open or short circuit in wiring from canister drain cut valve terminal A to main relay terminal D • Open or short circuit in wiring from canister drain cut valve terminal B to PCM terminal 4Z • Open or short circuit in wiring from tank pressure control valve terminal A to main relay terminal D • Open or short circuit in wiring from tank pressure control valve terminal B to PCM terminal 4Z



STEP	INSPECTION		ACTION
1	Does canister drain cut valve connector, tank pressure control valve connector or PCM connector have poor connection?	Yes	Repair or replace connector
		No	Go to next step
2	Is PCM terminal 4Z voltage OK? ➡ page F1-42	Yes	Go to step
		No	Go to next step
3	Disconnect canister drain cut valve connector. Turn ignition switch to ON. Is there battery positive voltage at harness side connector terminal A?	Yes	Go to next step
		No	Check for open or short circuit in wiring harness (Main relay terminal D — Canister drain cut valve terminal A)
4	Disconnect tank pressure control valve connector. Turn ignition switch to ON. Is there battery positive voltage at harness side connector terminal A?	Yes	Go to next step
		No	Check for open or short circuit in wiring harness (Main relay terminal D — Tank pressure control valve terminal A)
5	Is there continuity between canister drain cut valve harness side connector terminal B and PCM terminal 4Z?	Yes	Go to next step
		No	Repair or replace wiring harness
6	Is there continuity between tank pressure control valve harness side connector terminal B and PCM terminal 4Z?	Yes	Go to next step
		No	Repair or replace wiring harness
7	Is there continuity between canister drain cut valve terminals A and B?	Yes	Go to next step
		No	Replace canister drain cut valve
8	Is there continuity between tank pressure control valve terminals A and B?	Yes	Go to next step
		No	Replace tank pressure control valve
9	Erase diagnostic trouble code from memory. Is same code No. present after rechecking?	Yes	Replace PCM ➡ page F1-35
		No	Intermittent poor connection of harness or connector (Repair connector and/or harness)

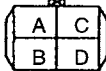

TPCV, CDCV
HARNESS SIDE CONNECTOR
(VIEW FROM BEHIND OF CONNECTOR)





Diagnostic trouble code No. P1455		FUEL TANK LEVEL SENSOR—OPEN OR SHORT	
Symptom		Input voltage from fuel tank level sensor is 0 V or above 4.98 V when ignition switch is turned on	
Possible cause		<ul style="list-style-type: none"> Fuel gauge sender unit malfunction Open or short circuit in wiring from fuel pump connector terminal C to PCM terminal 4M 	
STEP	INSPECTION	ACTION	
1	Does fuel pump connector or PCM 4M connector have poor connection?	Yes	Repair or replace connector
		No	Go to next step
2	Is PCM terminal 4M voltage OK? ☞ page F1-41	Yes	Go to step 7
		No	Go to next step
3	Is there continuity between fuel pump side connector terminal C and PCM terminal 4M?	Yes	Go to next step
		No	Repair or replace wiring harness
4	Is fuel gauge sender unit OK? ☞ section T	Yes	Go to next step
		No	Replace fuel gauge sender unit
5	Is fuel gauge OK? ☞ section T	Yes	Go to next step
		No	Repair or replace
6	Is there continuity between fuel pump harness side connector terminal C and instrument cluster?	Yes	Go to step 7
		No	Repair or replace wiring harness
7	Erase diagnostic trouble code from memory. Is same code No. present after rechecking?	Yes	Replace PCM ☞ page F1-35
		No	Intermittent poor connection of harness or connector (Repair connector and/or harness)
 <p>HARNESS SIDE CONNECTOR (VIEW FROM BEHIND OF CONNECTOR)</p>			

Diagnostic trouble code No. P1485	EGR (VACUUM)—OPEN OR SHORT
Symptom	Open or short circuit is observed in EGR solenoid valve (vacuum) system when ignition switch is turned on
Possible cause	<ul style="list-style-type: none"> • EGR solenoid valve (vacuum) malfunction • Open or short circuit in wiring from EGR solenoid valve (vacuum) terminal A to main relay terminal D • Open or short circuit in wiring from EGR solenoid valve (vacuum) terminal B to PCM terminal 4P

STEP	INSPECTION	ACTION	
1	Does EGR solenoid valve (vacuum) connector or PCM connector have poor connection?	Yes	Repair or replace connector
		No	Go to next step
2	Is PCM terminal 4P voltage OK?  page F1-41	Yes	Go to step 6
		No	Go to next step
3	Disconnect EGR solenoid valve connector. Turn ignition switch to ON. Is there battery positive voltage at harness side connector terminal A?	Yes	Go to next step
		No	Check for open or short circuit in wiring harness. (Main relay terminal D — EGR solenoid valve (vacuum) terminal A)
4	Is there continuity between harness side connector terminal B and PCM terminal 4P?	Yes	Go to next step
		No	Repair or replace wiring harness
5	Is there continuity between EGR solenoid valve (vacuum) terminals A and B?	Yes	Go to next step
		No	Replace EGR solenoid valve (vacuum)  page F1-25
6	Erase diagnostic trouble code from memory. Is same code No. present after rechecking.	Yes	Replace PCM  page F1-35
		No	Intermittent poor connection of harness or connector (Repair connector and/or harness)



HARNESS SIDE CONNECTOR
(VIEW FROM BEHIND OF CONNECTOR)

Diagnostic trouble code No. P1486		EGR (VENT)—OPEN OR SHORT	
Symptom		Open or short circuit is observed in EGR solenoid valve (vent) system when ignition switch is turned on	
Possible cause		<ul style="list-style-type: none"> • EGR solenoid valve (vent) malfunction • Open or short circuit in wiring from EGR solenoid valve (vent) terminal A to main relay terminal D • Open or short circuit in wiring from EGR solenoid valve (vent) terminal B to PCM terminal 4O 	
STEP	INSPECTION	ACTION	
1	Does EGR solenoid valve (vent) connector or PCM connector have poor connection?	Yes	Repair or replace connector
		No	Go to next step
2	Is PCM terminal 4O voltage OK?  page F1-41	Yes	Go to step 6
		No	Go to next step
3	Disconnect EGR solenoid valve (vent) connector. Turn ignition switch to ON. Is there battery positive voltage at harness side connector terminal A?	Yes	Go to next step
		No	Check for open or short circuit in wiring harness. (Main relay terminal D — EGR solenoid valve (vent) terminal A)
4	Is there continuity between harness side connector terminal B and PCM terminal 4O?	Yes	Go to next step
		No	Repair or replace wiring harness
5	Is there continuity between EGR solenoid valve (vent) terminals A and B?	Yes	Go to next step
		No	Replace EGR solenoid valve (vent)  page F1-25
6	Erase diagnostic trouble code from memory. Is same code No. present after rechecking.	Yes	Replace PCM  page F1-35
		No	Intermittent poor connection of harness or connector (Repair connector and/or harness)
 <p>HARNESS SIDE CONNECTOR (VIEW FROM BEHIND OF CONNECTOR)</p>			



Diagnostic trouble code No. P1487	EGRCHK SOL.—OPEN OR SHORT
Symptom	Open or short circuit is observed in EGR boost sensor solenoid valve system when ignition switch is turned on
Possible cause	<ul style="list-style-type: none"> • EGR boost sensor solenoid valve malfunction • Open or short circuit in wiring from EGR boost sensor solenoid valve terminal A to main relay terminal D • Open or short circuit in wiring from EGR boost sensor solenoid valve B to PCM terminal 4L

STEP	INSPECTION		ACTION
1	Does EGR boost sensor solenoid valve connector or PCM connector have poor connection?	Yes	Repair or replace connector
		No	Go to next step
2	Is PCM terminal 4P voltage OK? ➡ page F1-41	Yes	Go to step 6
		No	Go to next step
3	Disconnect EGR boost sensor solenoid valve connector. Turn ignition switch to ON. Is there battery positive at harness side connector terminal A?	Yes	Go to next step
		No	Check for open or short circuit in wiring harness (Main relay terminal D — EGR boost sensor solenoid valve terminal A)
4	Is there continuity between harness side connector terminal B and PCM terminal 4P?	Yes	Go to next step
		No	Repair or replace wiring harness
5	Is there continuity between EGR boost sensor solenoid valve terminals A and B?	Yes	Go to next step
		No	Replace EGR boost sensor solenoid valve ➡ page F1-25
6	Erase diagnostic trouble code from memory. Is same code No. present after rechecking?	Yes	Replace PCM ➡ page F1-35
		No	Intermittent poor connection of harness or connector (Repair connector and/or harness)



HARNESS SIDE CONNECTOR
(VIEW FROM BEHIND OF CONNECTOR)

Diagnostic trouble code No. P1608	PCME (CPU)—MALFUNCTION		
Symptom	PCM does not read diagnostic trouble codes from output devices		
Possible cause	<ul style="list-style-type: none"> • PCM malfunction 		
STEP	INSPECTION		ACTION
—	—		Replace PCM  page F1-35

Diagnostic trouble code No. P1794	BAT—BAT OR CIRCUIT FAIL		
Symptom	Battery positive voltage is not constantly applied to PCM terminal 4I		
Possible cause	<ul style="list-style-type: none"> • Battery malfunction • Open or short circuit in wiring from PCM terminal 4I to battery positive cable • Burnt fuse 		
STEP	INSPECTION		ACTION
1	Is battery fully charged?  section G	Yes	Go to next step
		No	Charge battery  section G
2	Does battery positive voltage present at PCM terminal 4I?	Yes	Go to next step
		No	Check for open or short circuit in wiring harness (PCM terminal 4I — Battery)
3	Erase diagnostic trouble code from memory. Is same code No. present after rechecking?	Yes	Replace PCM  page F1-35
		No	Intermittent poor connection of harness or connector (Repair connector and/or harness)

Diagnostic trouble code No. P1797	PNS—OPEN OR SHORT		
Symptom	<ul style="list-style-type: none"> • PCM judges N position for more than 33 seconds when shift lever is in D range • PCM judges neutral/clutch switch OFF for more than 5 seconds while vehicle stopped and engine running 		
Possible cause	<ul style="list-style-type: none"> • Transaxle range switch malfunction • Clutch/neutral switch malfunction • PCM malfunction • Open or short circuit in wiring from transaxle range switch terminal H or neutral/clutch switch terminal to PCM terminal 1L 		
STEP	INSPECTION	ACTION	
1	Does PCM connector have poor connection?	Yes	Repair or replace connector
		No	Go to next step
2	Is PCM terminal 1L voltage OK? ☞ page F1-38	Yes	Go to step 5
		No	Go to next step
3	Is there continuity between transaxle range switch terminal H or clutch/neutral switch terminal and PCM terminal 1L?	Yes	Go to next step
		No	Repair or replace wiring harness
4	(ATX) Is transaxle range switch OK? (MTX) Is neutral/clutch switch OK? ☞ section K ☞ page F1-52	Yes	Go to next step
		No	Repair or replace transaxle range switch or neutral/clutch switch ☞ section K, page F1-52
5	Erase diagnostic trouble code from memory. Is same code No. present after rechecking?	Yes	Replace PCM ☞ page F1-35
		No	Intermittent poor connection of harness or connector (Repair connector and/or harness)

TROUBLESHOOTING

USING THIS SECTION

Procedure

Service section

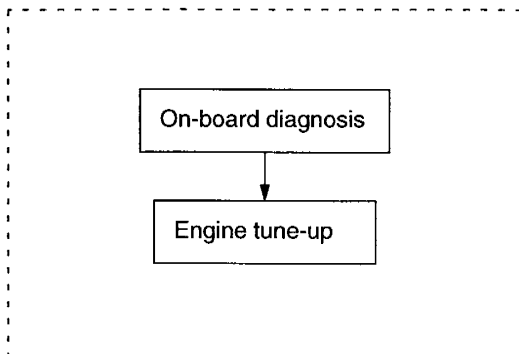

- If diagnostic trouble codes present, carry out inspection required by the code indicated. (Refer to page F1-54.)
- If engine operates, carry out engine tune-up. (Refer to page F1-2.)

Troubleshooting section

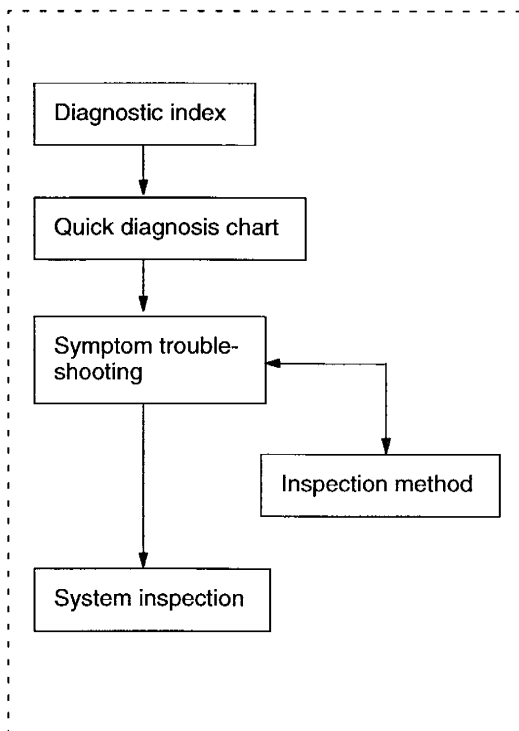

- If problems can not be solved by following procedure in service section, go to troubleshooting section.
- Choose item that most closely corresponds to actual symptom. (Refer to page F1-95.)
- Referring to quick diagnosis chart, assume systems related to the problem. (Refer to page F1-96.)
- Referring to symptom troubleshooting, locate the cause of trouble. (Refer to page F1-98.)
- Inspect the suspected faulty system and repair or replace as necessary.

Description

Diagnostic index

- The diagnostic index is for quick reference of all trouble symptoms in the symptom troubleshooting.
- Detailed description of each symptom enables correct inspection.

DIAGNOSTIC INDEX				
No.	TROUBLESHOOTING ITEM	DESCRIPTION	PAGE	
1	Engine hard to start	Discharged battery	F1-98	
2		Will not crank or cranks slowly	F1-98	
3		No combustion	Engine cranks at normal speed but shows no sign of firing	F1-99
4		Combustion observed but engine will not start	Engine shows combustion while cranking but will not continue to run when ignition switch is turned from STA to ON	F1-100
5		Cranks normally but hard to start	Engine cranks at normal speed but requires excessive cranking time before starting Engine runs normally at idle after started	F1-102
6	High idle	Low idle speed/Engine stalls or vibrates	Engine idles at low speed, stalls, or vibrates when engine is cold, hot, or normal temperature	F1-103
7		High idle speed	Idle speed excessively high and will not go down after warm-up	F1-105

Quick diagnosis chart

- Troubleshooting index shows relationship between trouble symptoms and suspected faulty parts.
- This index is for quick location of the cause of trouble. In case several problems exist, a common cause that may be related to them can also be easily found.

Troubleshooting Item	Possible factor	A/F lean											A/F rich			Insufficient intake air				Low intake air flow																		
		No spark	Incorrect ignition timing	No load signal always input to PCM	Excessive spark advance	No firing in some cylinders	No fuel supply	Insufficient fuel supply	Fuel injector restrained	Fuel injector clogged	No injection in some cylinder	Throttle position sensor malfunction	Low fuel pressure	Fuel pressure not held	STA signal not input to PCM	Air sucked in	A/F lean during acceleration	Some fuel injectors remained open	Excessive fuel injector operation time	Excessive fuel pressure	Fuel leakage from fuel injector	A/F rich during acceleration	IAC valve not operation	Open or short circuit between ECU and IAC valve or wrong IAC valve-PCM	IAC valve internal circuit open	IAC correction over limit	Idle-up signal not input to PCM	No load judgement	Intake-air system clogged	Exhaust system clogged	Excessive intake air	A/F valve malfunction	Inert gas inflow	Evaporative gas inflow				
1	Discharged battery																																					
2	Will not crank slowly																																					
3	No combustion	○																																				
4	Combustion observed but engine will not start		○																																			
5	Cranks normally but hard to start													○																								
6	Low idle speed/Engine stalls or vibrates	○	○																																			
7	High idle speed/Idle speed																																					

Cause of trouble common to trouble symptoms No.3, 4, 6

Cause of trouble precursor to trouble symptom No.5

Symptom troubleshooting

- Symptom troubleshooting shows diagnosis procedure, inspection method, and proper action to take for each trouble symptom.

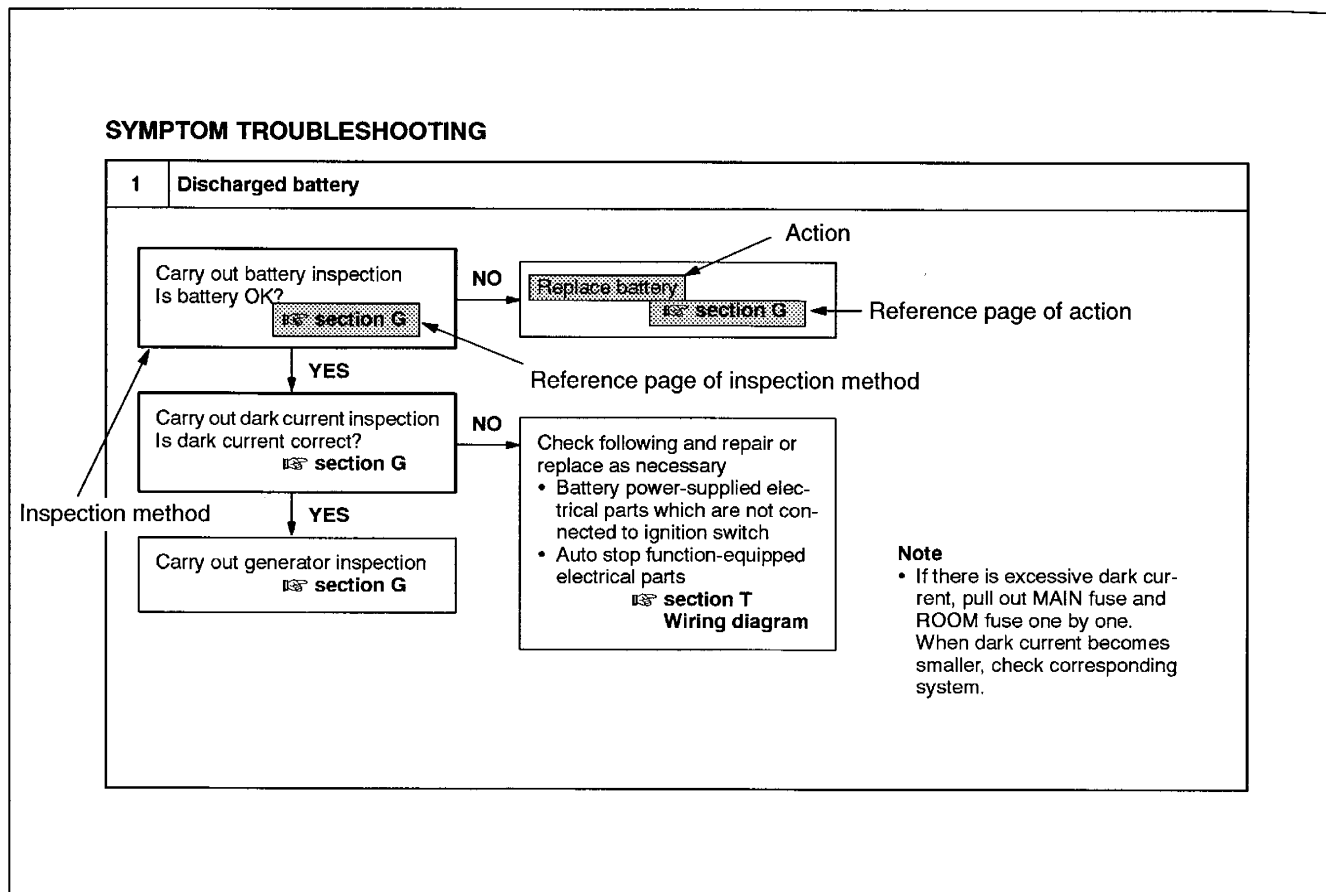

Inspection method

- Inspection methods necessary for troubleshooting are shown per each trouble symptom.
- Efficient troubleshooting is made possible by following this inspection method.

System inspection

- Inspection items necessary for troubleshooting are shown per each system.
- Efficient troubleshooting is made possible by this system inspection.

DIAGNOSTIC INDEX

No.	TROUBLESHOOTING ITEM	DESCRIPTION	PAGE	
1	Engine hard to start	Discharged battery	F1-98	
2		Will not crank or cranks slowly	F1-98	
3		No combustion	Engine cranks at normal speed but shows no sign of firing	F1-99
4		Combustion observed but engine will not start	Engine shows combustion while cranking but will not continue to run when ignition switch is turned from STA to ON	F1-100
5		Cranks normally but hard to start	Engine cranks at normal speed but requires excessive cranking time before starting Engine runs normally at idle after started	F1-102
6	Rough idle	Low idle speed/Engine stalls or vibrates	Engine idles at low speed, stalls, or vibrates when engine is cold, hot, or normal temperature	F1-103
7		High idle speed Idle speed remains high	Idle speed excessively high and will not go down after warm-up	F1-105
8		High idle speed Idle speed hard to lower	Idle speed excessively high and requires times to be lowered to normal speed after warm-up	F1-106
9	Engine stalls	Rough idle/Engine stalls when E/L, P/S, or A/C ON	Engine runs normally at idle with no load but stalls or vibrates excessively when load (E/L, P/S, or A/C) is ON	F1-106
10		Rough idle/Engine stalls during N-D shift (ATX)	Engine runs normally at idle but stalls or vibrates excessively during N-D shift	F1-107
11		Engine stalls when vehicle about to run	—	F1-108
12		Engine stalls on acceleration and while cruising	—	F1-109
13	Poor acceleration/Insufficient power/Surges while cruising/Hesitates	—	F1-110	
14	Runs rough during deceleration/Backfire	Engine runs rough during deceleration, and abnormal combustion occurs in exhaust system	F1-112	
15	Knocking	—	F1-113	
16	Overheating	—	F1-114	
17	Poor fuel economy	Fuel consumption increased excessively though no sudden starting, acceleration, or braking carried out	F1-115	
18	Fuel odor	Fuel odor in passenger or engine compartment	F1-116	

QUICK DIAGNOSIS CHART

Troubleshooting item		Possible factor																															
		No spark	Incorrect ignition timing	No load signal always input to PCM	Excessive spark advance	No firing in some cylinders	No fuel supply	A/F lean				A/F rich				Insufficient intake air				Low intake/exhaust efficiency													
							Insufficient fuel supply	Fuel injector restrained	Fuel injector clogged	No injection in some cylinder	Throttle position sensor malfunction	Low fuel pressure	Fuel pressure not held	Air sucked in	A/F lean during acceleration	Some fuel injectors remained open	Excessive fuel injector operation time	Excessive fuel pressure	Fuel leakage from fuel injector	A/F rich during acceleration	IAC valve not operation	Open or short circuit between relay—IAC valve or between IAC valve—PCM	IAC valve internal circuit open	IAC correction over limit	Idle-up signal not input to PCM	No load judgement	Intake-air system clogged	Exhaust system clogged	Excessive intake air	Air valve malfunction	Inert gas inflow	Evaporative gas inflow	Evaporative gas leakage
1	Engine hard to start	Discharged battery																															
2		Will not crank/ Crank slowly																															
3		No combustion																															
4		Combustion observed but engine will not start																															
5		Crank normally but hard to start																															
6	Rough idle	Low idle speed/ Engine stalls or vibrates																															
7		High idle speed Idle speed remains high																															
8		High idle speed Idle speed hard to lower																															
9	Rough idle/Engine stalls when E/L, P/S, or A/C ON																																
10	Rough idle/Engine stalls during N-D shift (ATX)																																
11	Engine stalls	Engine stalls when vehicle about to run																															
12		Engine stalls on acceleration and while cruising																															
13	Poor acceleration/ Insufficient power/ Surges while cruising/ Hesitates																																
14	Runs rough during deceleration/Backfire																																
15	Knocking																																
16	Overheating																																
17	Poor fuel economy																																
18	Fuel odor																																

													Possible factor			
													Troubleshooting item			
Fuel leakage													<input type="checkbox"/>	Discharged battery	Engine hard to start	1
Improper fuel													<input type="checkbox"/>	Will not crank/ Crank slowly		2
Low fuel octane number	<input type="checkbox"/>												<input type="checkbox"/>	No combustion		
PCM not actuated (Include CPU malfunction)													<input type="checkbox"/>	Combustion observed but engine will not start	4	
Improper PCM ground point													<input type="checkbox"/>	Crank normally but hard to start		5
Not fuel cut during deceleration													<input type="checkbox"/>	Low idle speed/ Engine stalls or vibrates	Rough idle	6
Delayed fuel injection recovery timing													<input type="checkbox"/>	High idle speed Idle speed remains high		7
Incorrect fuel amount at fuel injection recovery													<input type="checkbox"/>	High idle speed Idle speed hard to lower		8
Knocking													<input type="checkbox"/>	Rough idle/Engine stalls when E/L, P/S, or A/C ON	9	
Preignition													<input type="checkbox"/>	Rough idle/Engine stalls during N-D shift (ATX)		10
Overheating													<input type="checkbox"/>	Engine stalls when vehicle about to run	Engine stalls	11
Insufficient air flow amount													<input type="checkbox"/>	Engine stalls on acceleration and while cruising		12
Inoperative radiator													<input type="checkbox"/>	Poor acceleration/ Insufficient power/ Surges while cruising/ Hesitates	13	
Coolant leakage													<input type="checkbox"/>	Runs rough during deceleration/Backfire		14
Poor coolant circulation													<input type="checkbox"/>	Knocking	15	
Engine coolant temperature gauge needle points H													<input type="checkbox"/>	Overheating		16
Excessive mechanical resistance													<input type="checkbox"/>	Poor fuel economy	17	
No compression in all cylinders													<input type="checkbox"/>	Fuel odor		18
No compression in some cylinders													<input type="checkbox"/>			
High compression ratio													<input type="checkbox"/>			
High compression pressure													<input type="checkbox"/>			
Excessive valve overlap													<input type="checkbox"/>			
Incorrect valve timing													<input type="checkbox"/>			
Insufficient starter power													<input type="checkbox"/>			
Malfunction of starting system-related components													<input type="checkbox"/>			
Higher actual load													<input type="checkbox"/>			
A/C load will not turn off													<input type="checkbox"/>			
Warning light malfunction													<input type="checkbox"/>			
Clutch disc slipping (MTX)													<input type="checkbox"/>			
Brake dragging													<input type="checkbox"/>			
Low tire pressure													<input type="checkbox"/>			
Discharged battery													<input type="checkbox"/>			
Large dark current													<input type="checkbox"/>			

SYMPTOM TROUBLESHOOTING

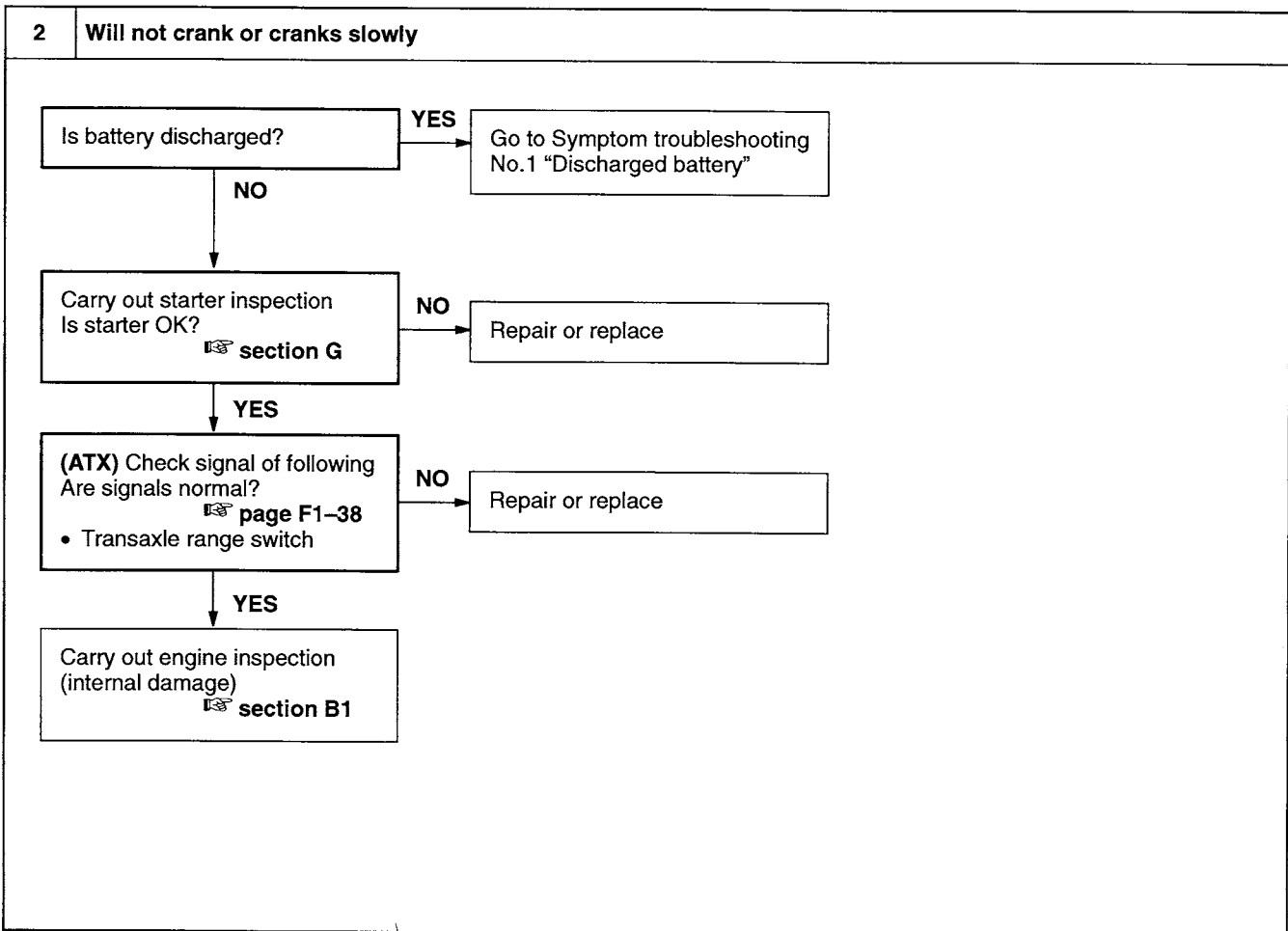
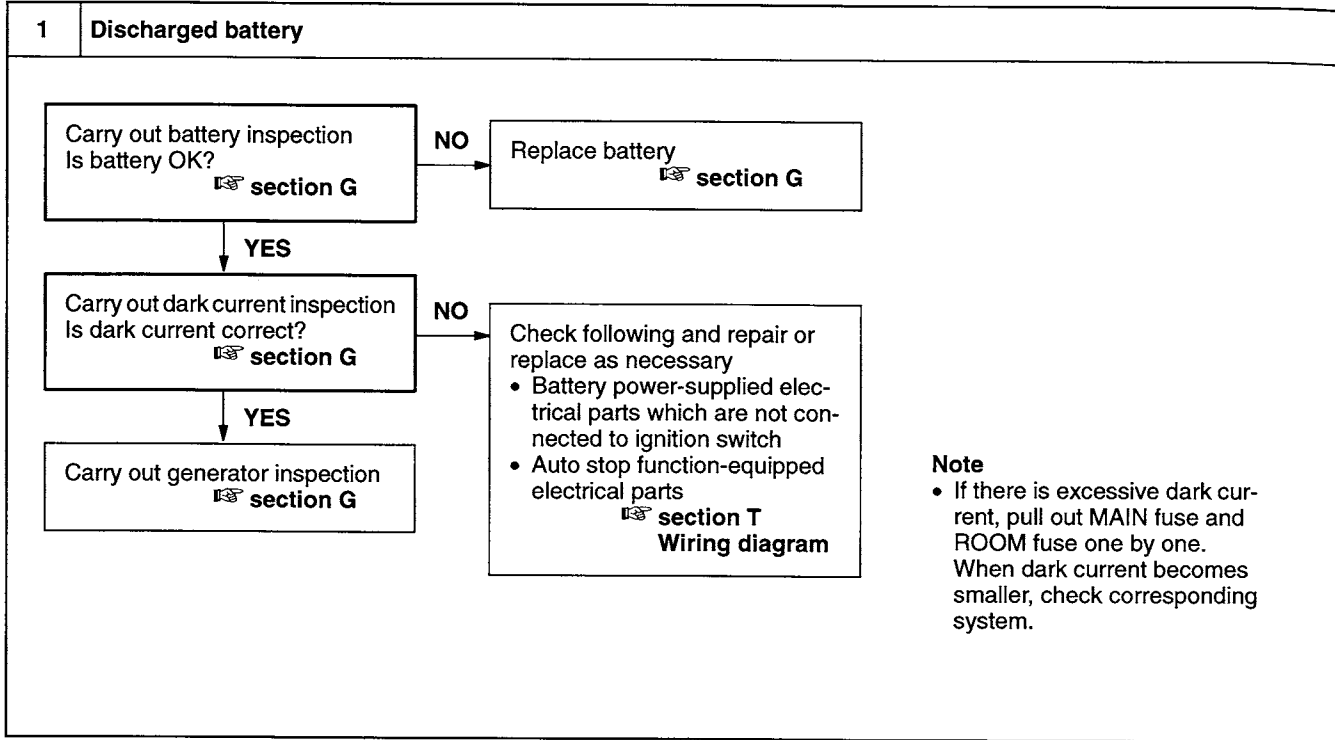

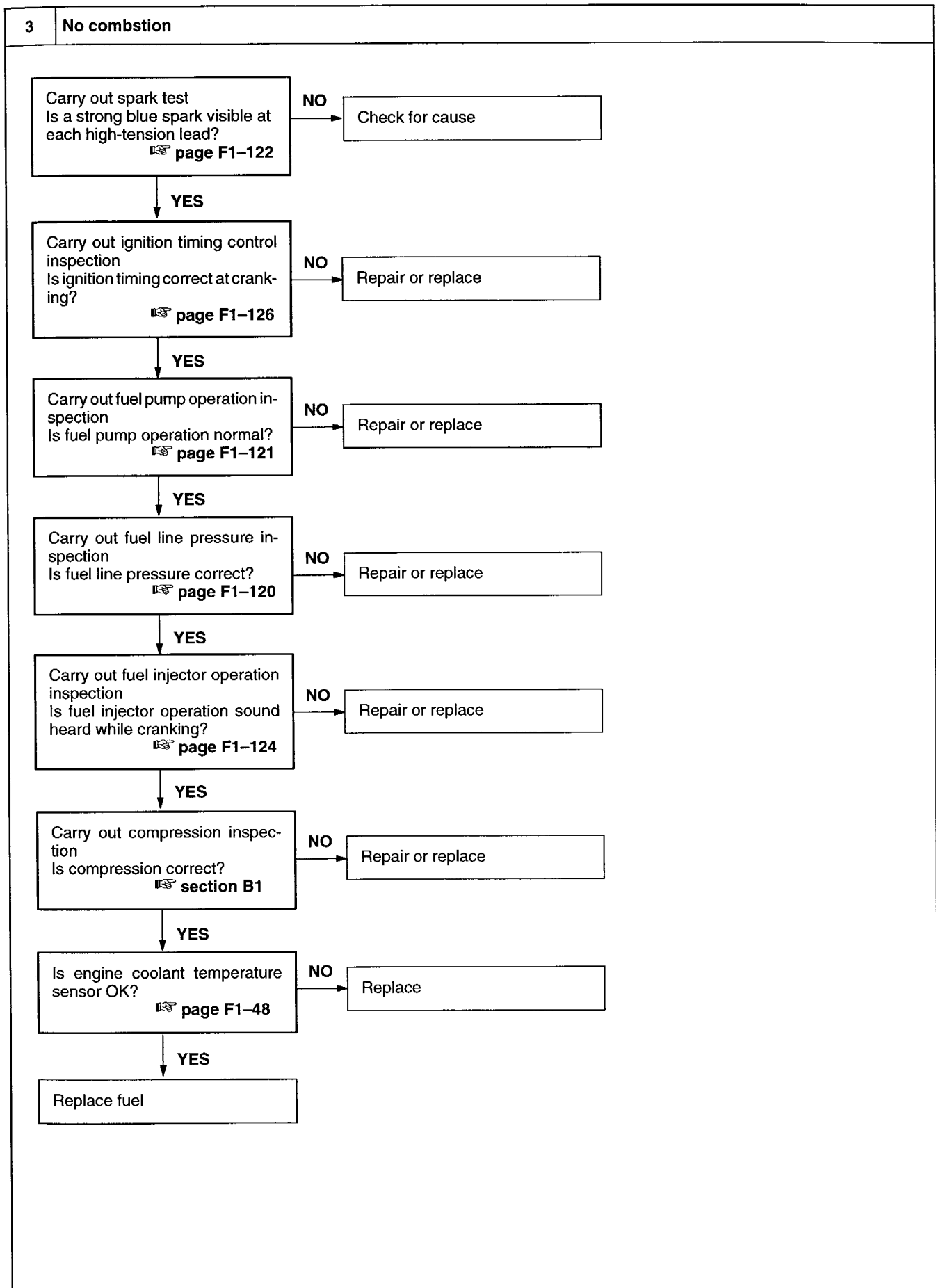

4 Combustion observed but engine will not start

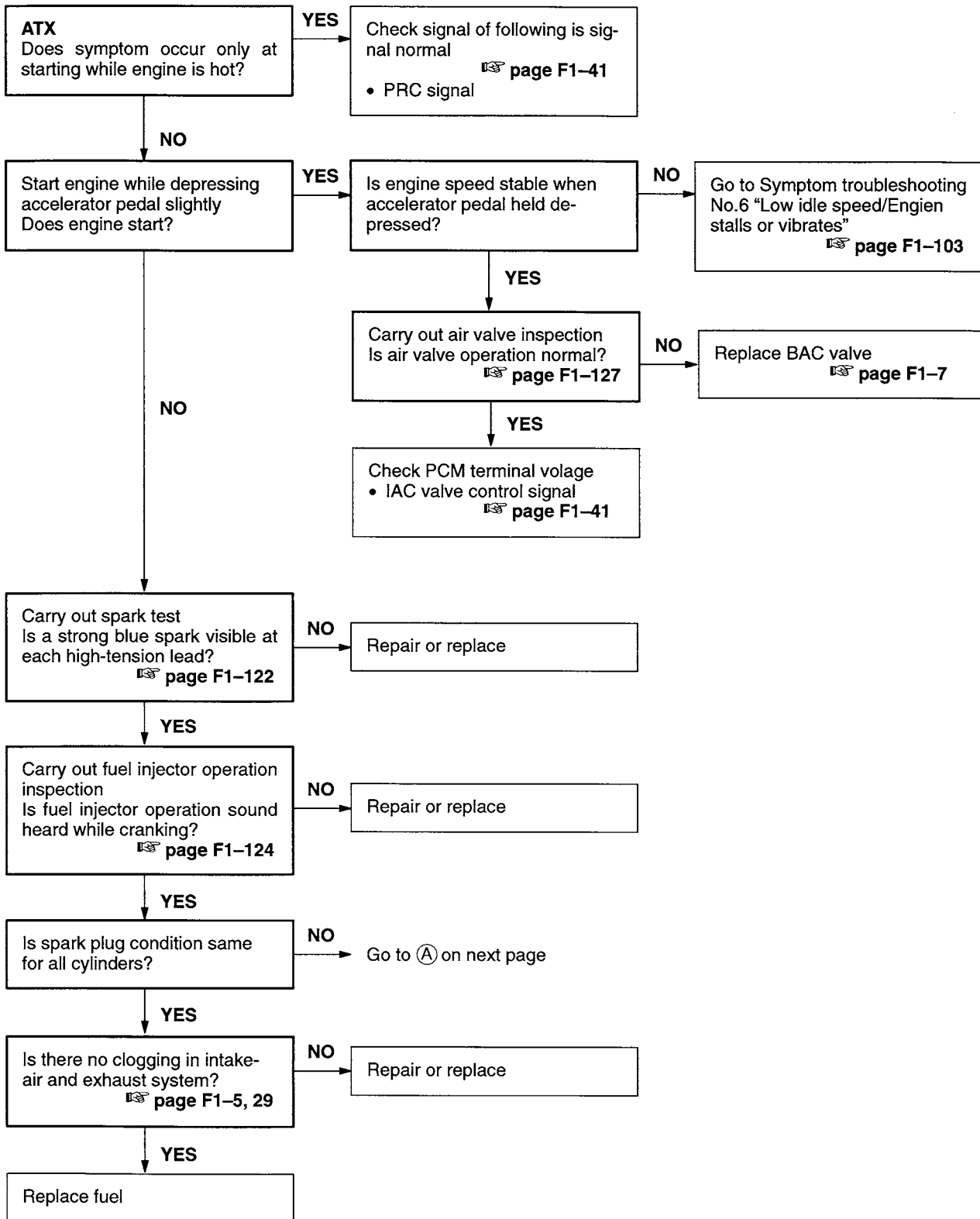

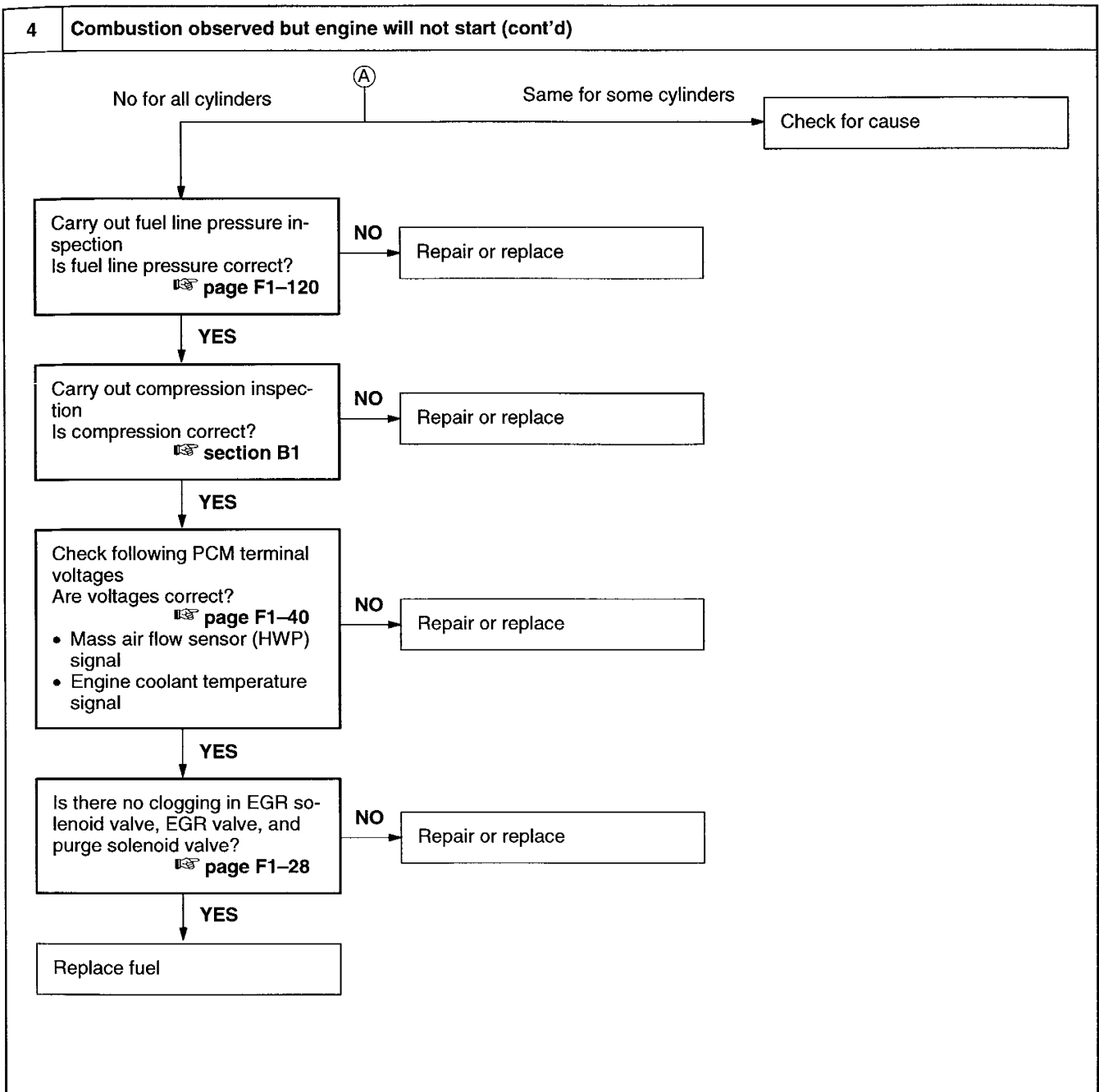

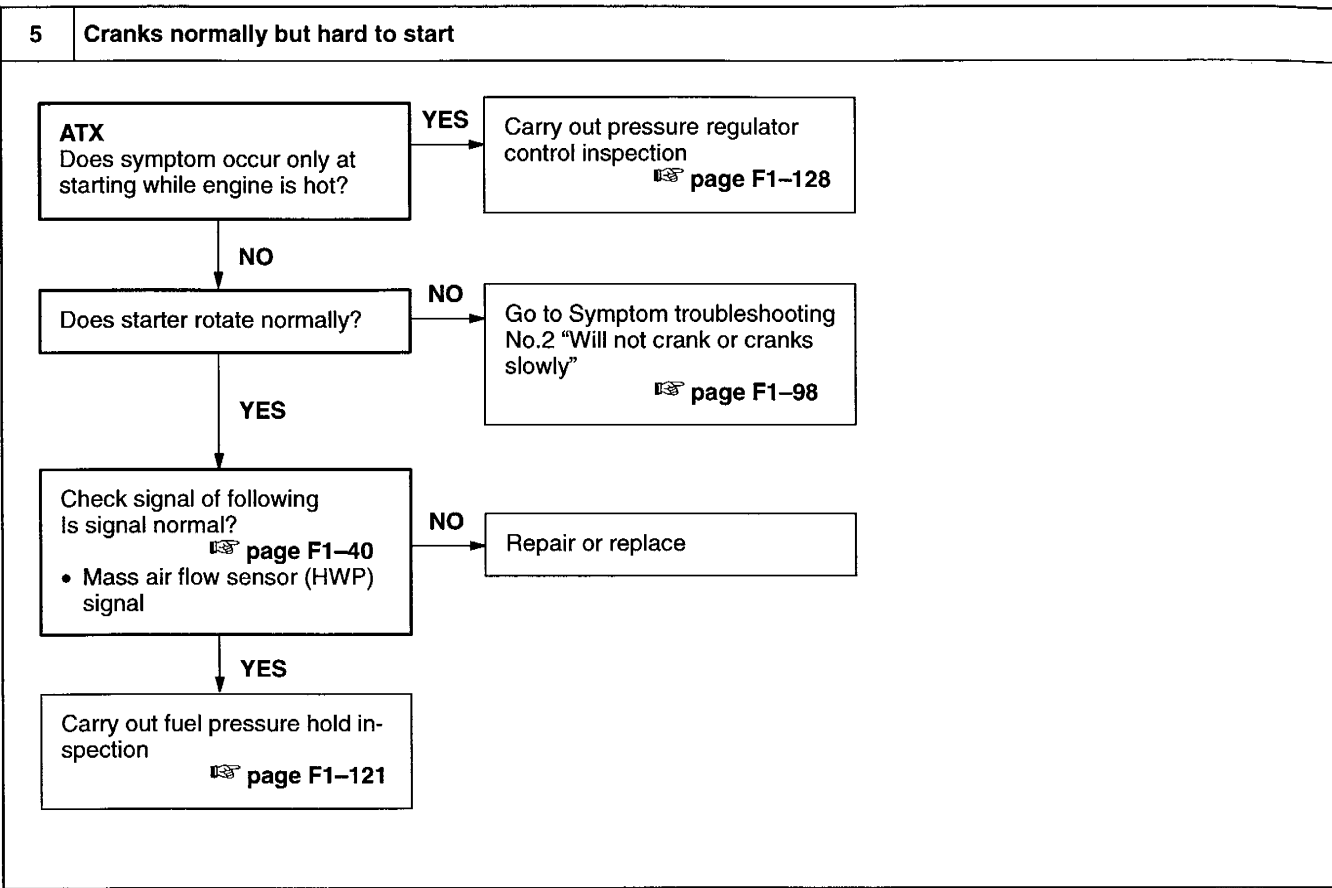

6 Low idle speed/Engine stalls or vibrates

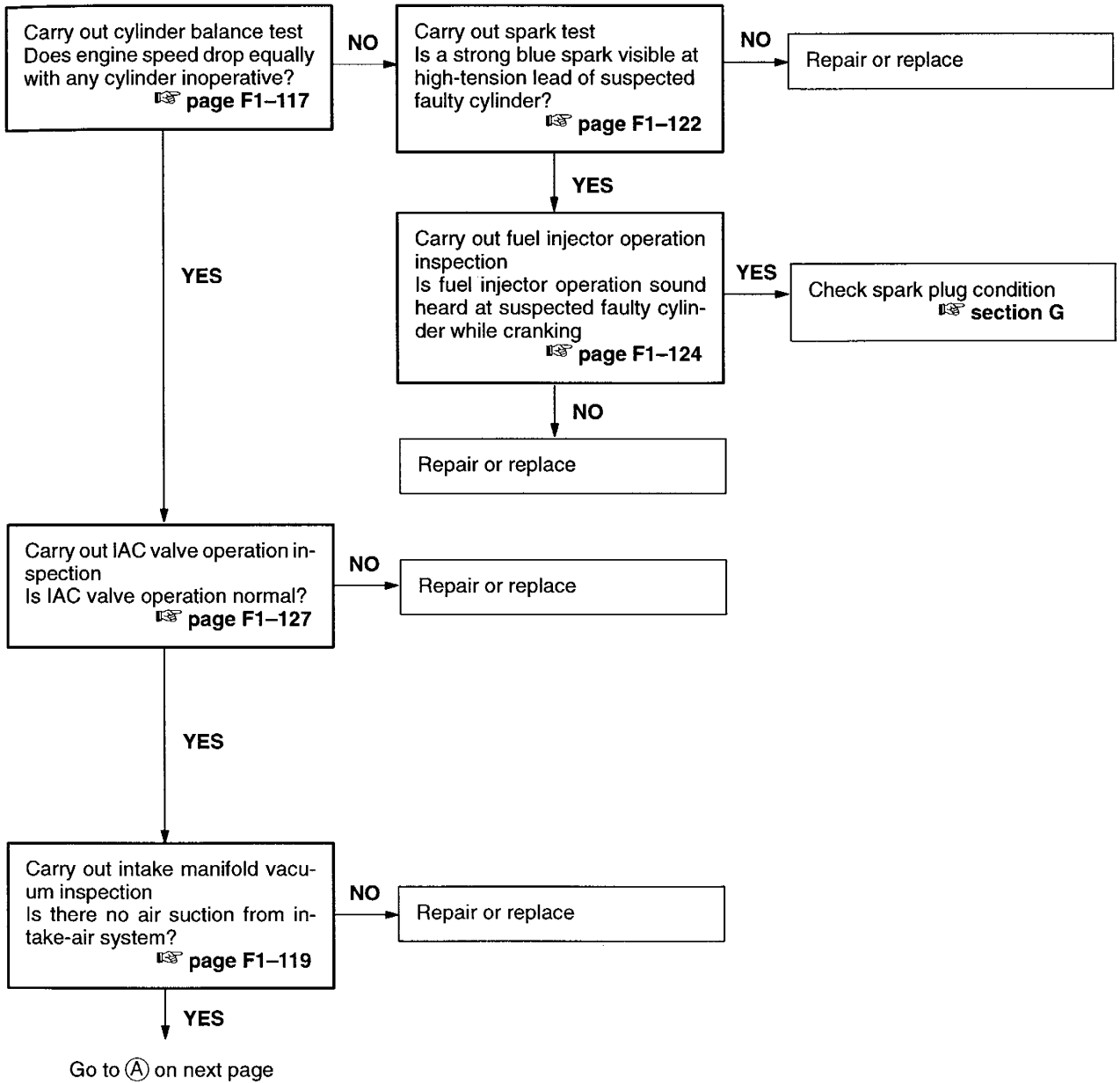

6 Low idle speed/Engine stalls or vibrates (cont'd)

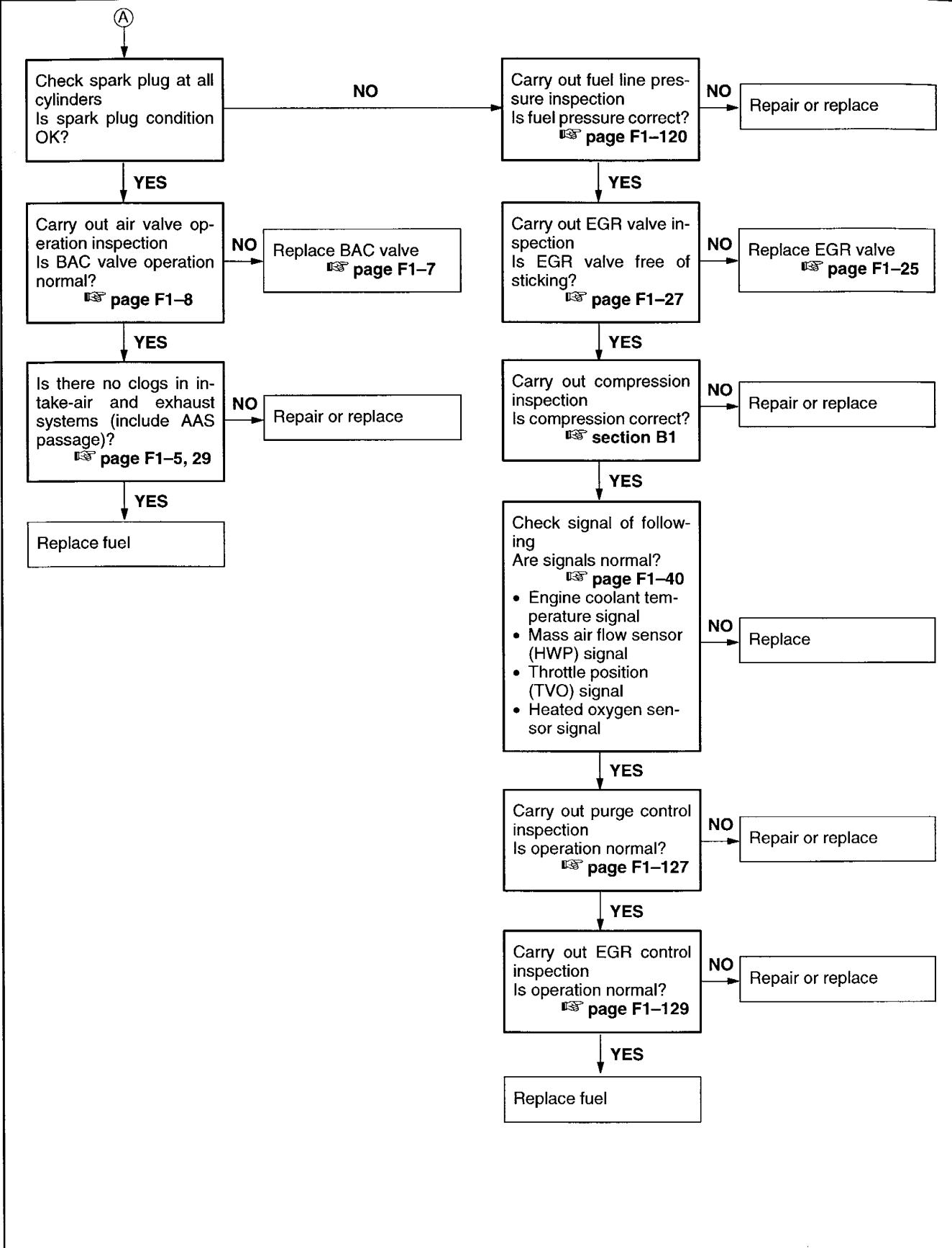

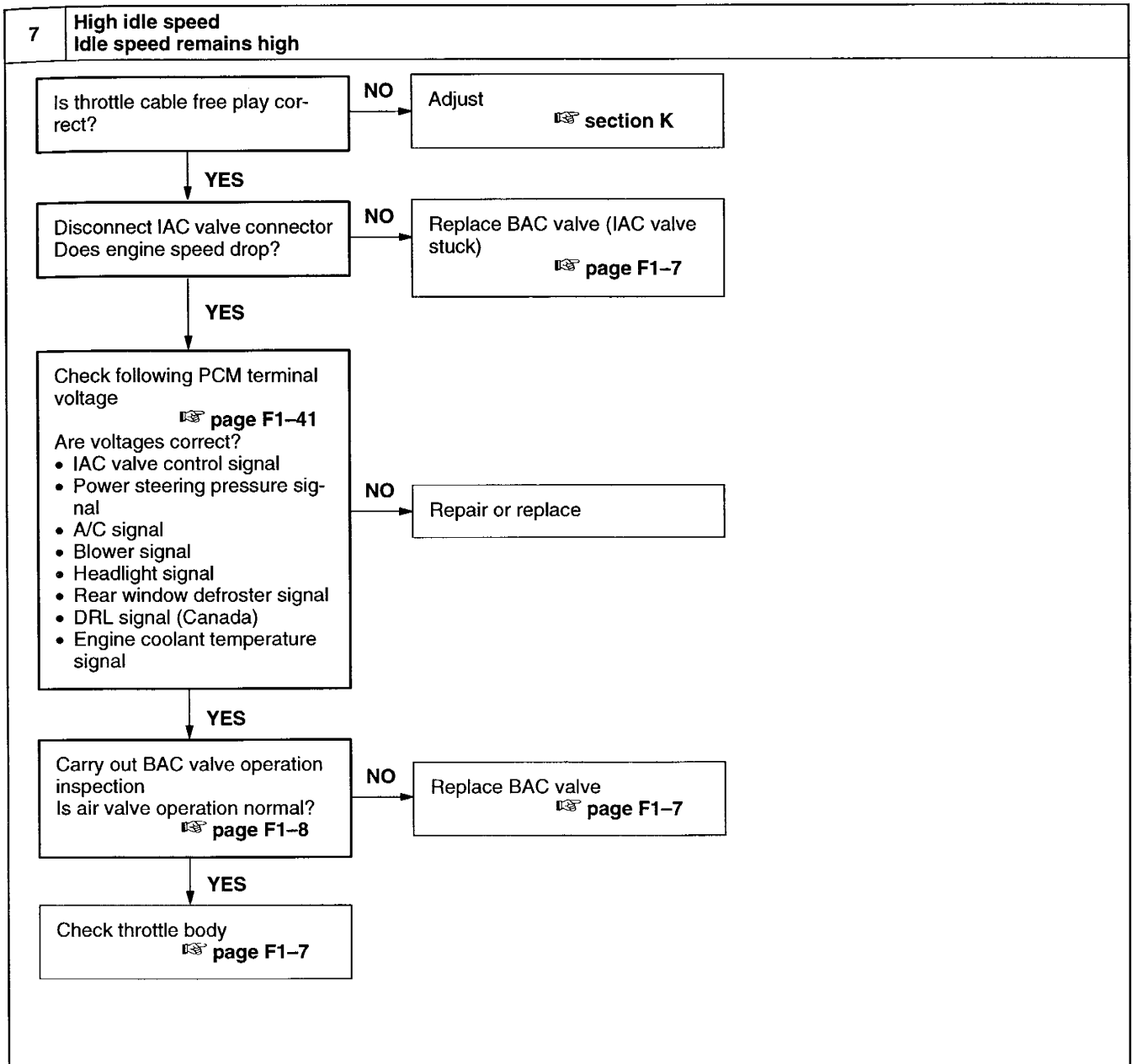

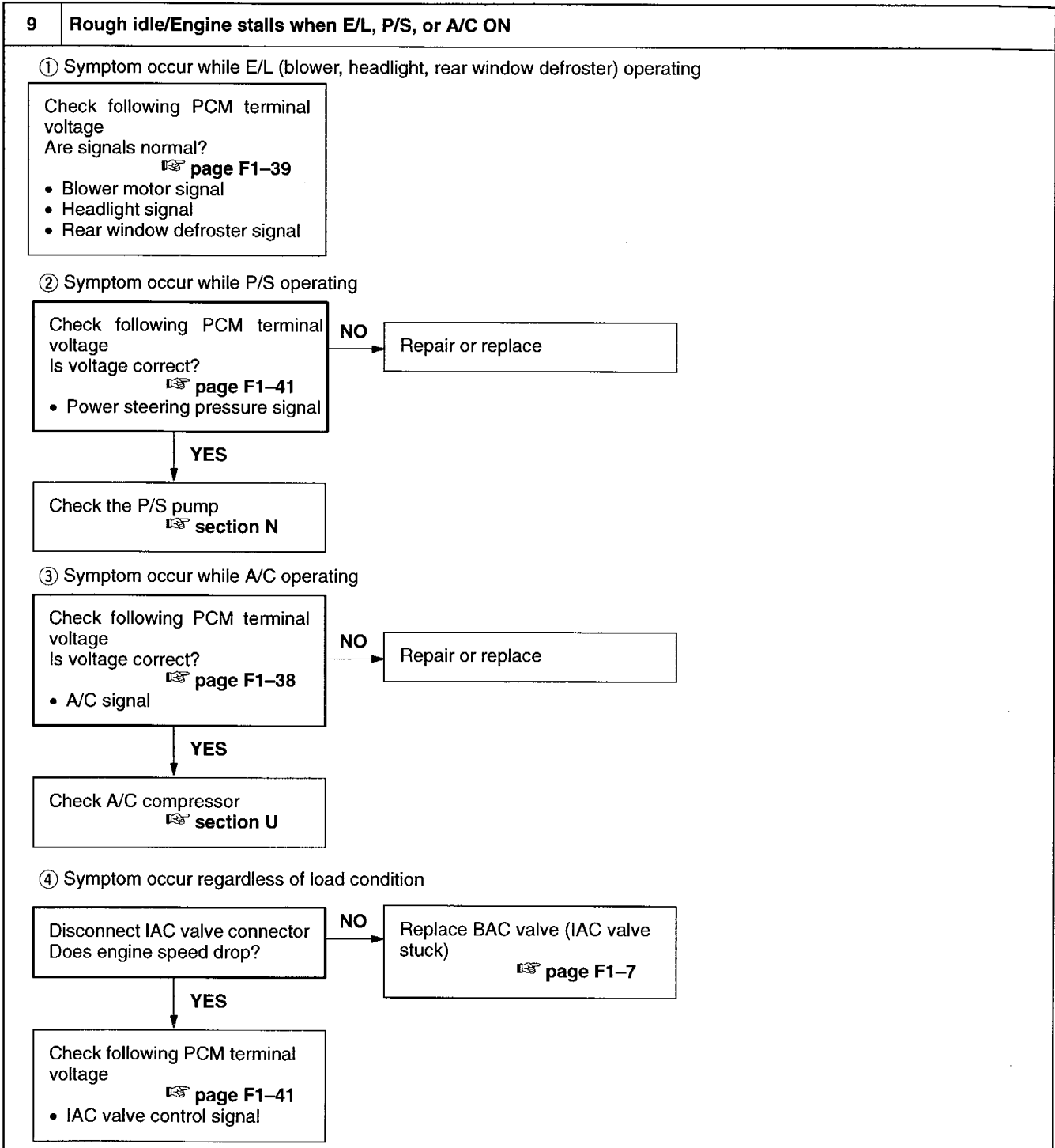
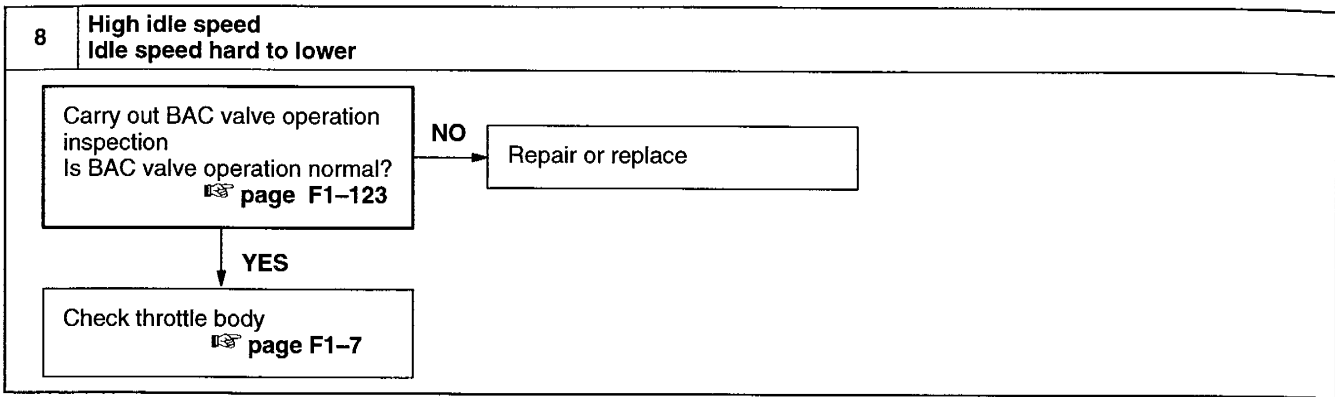

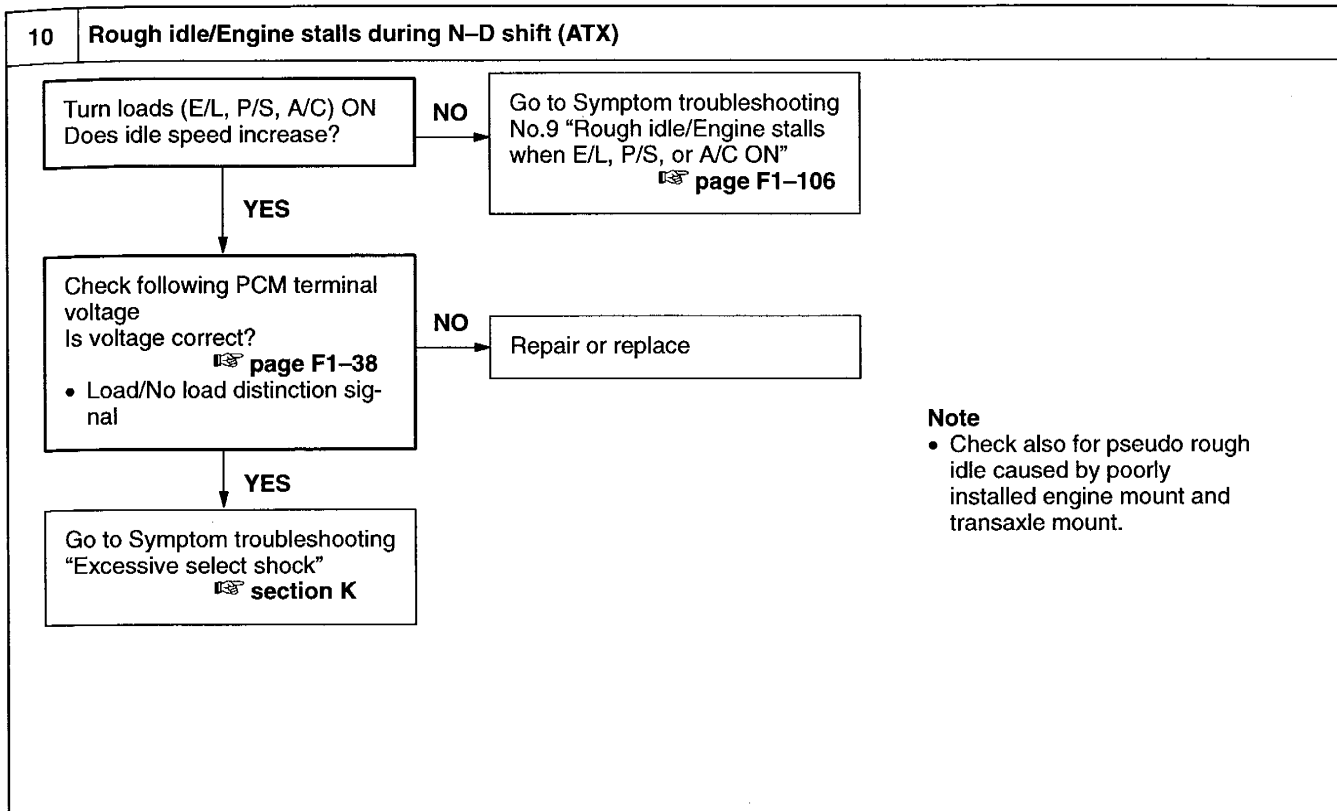

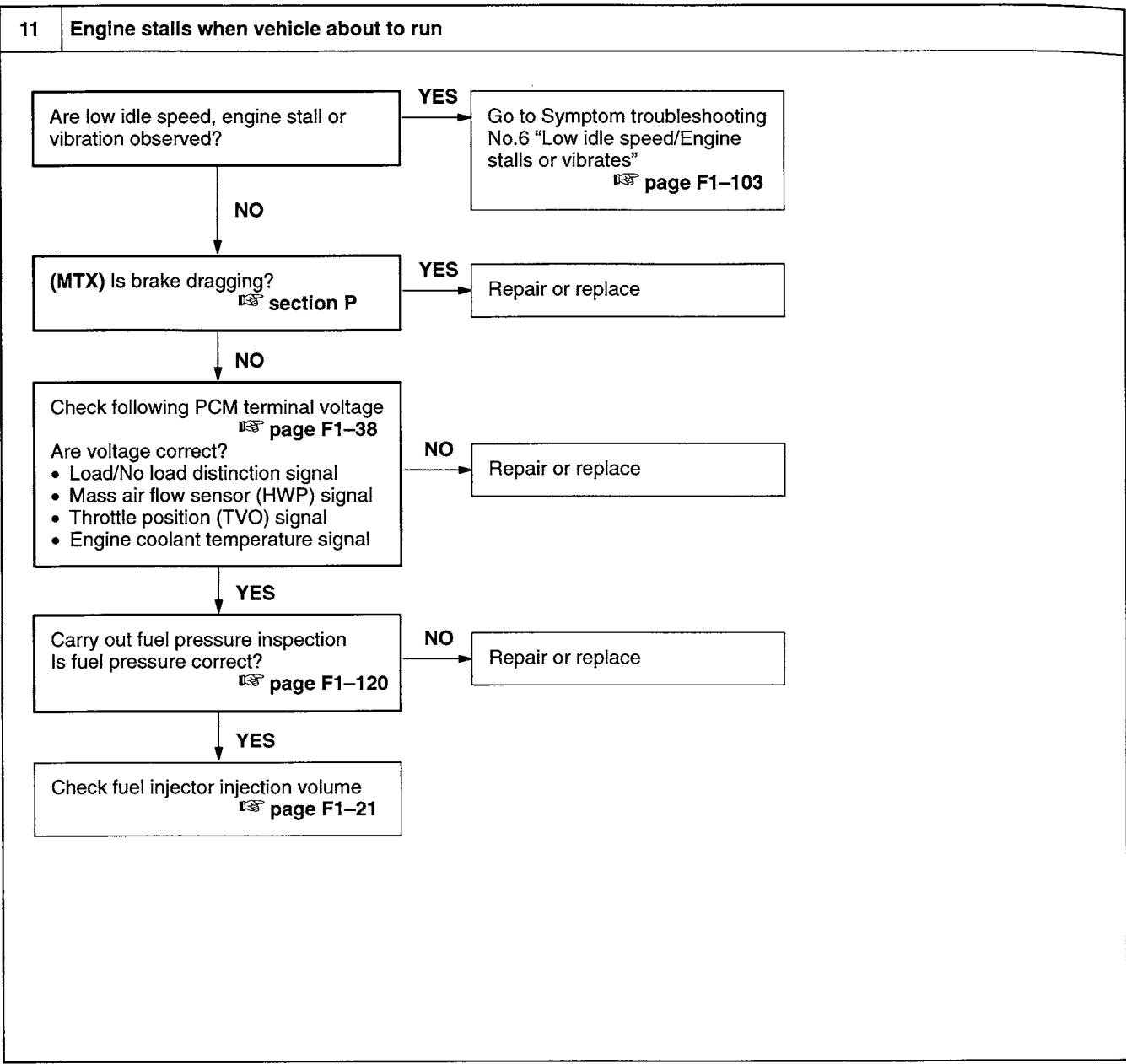

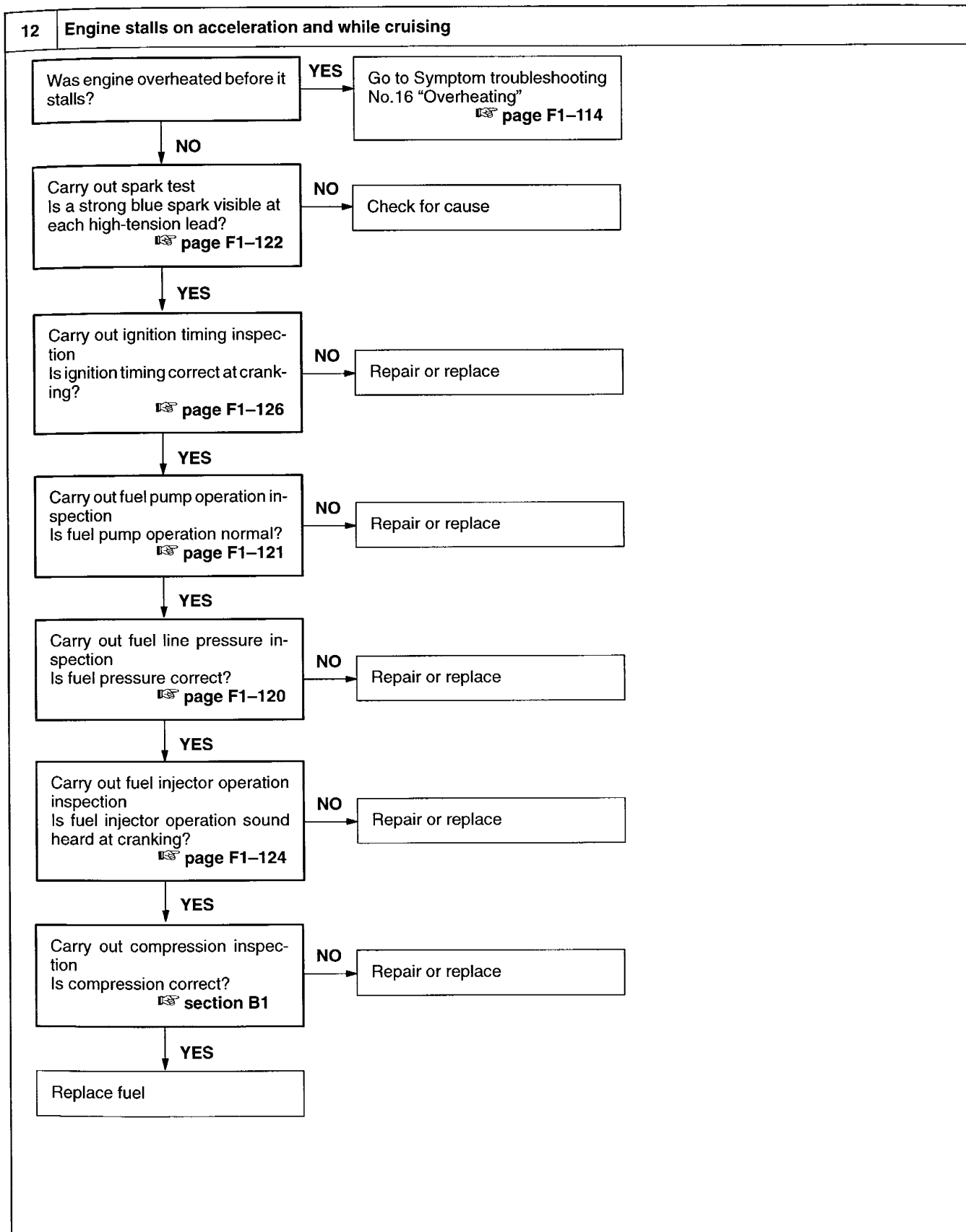

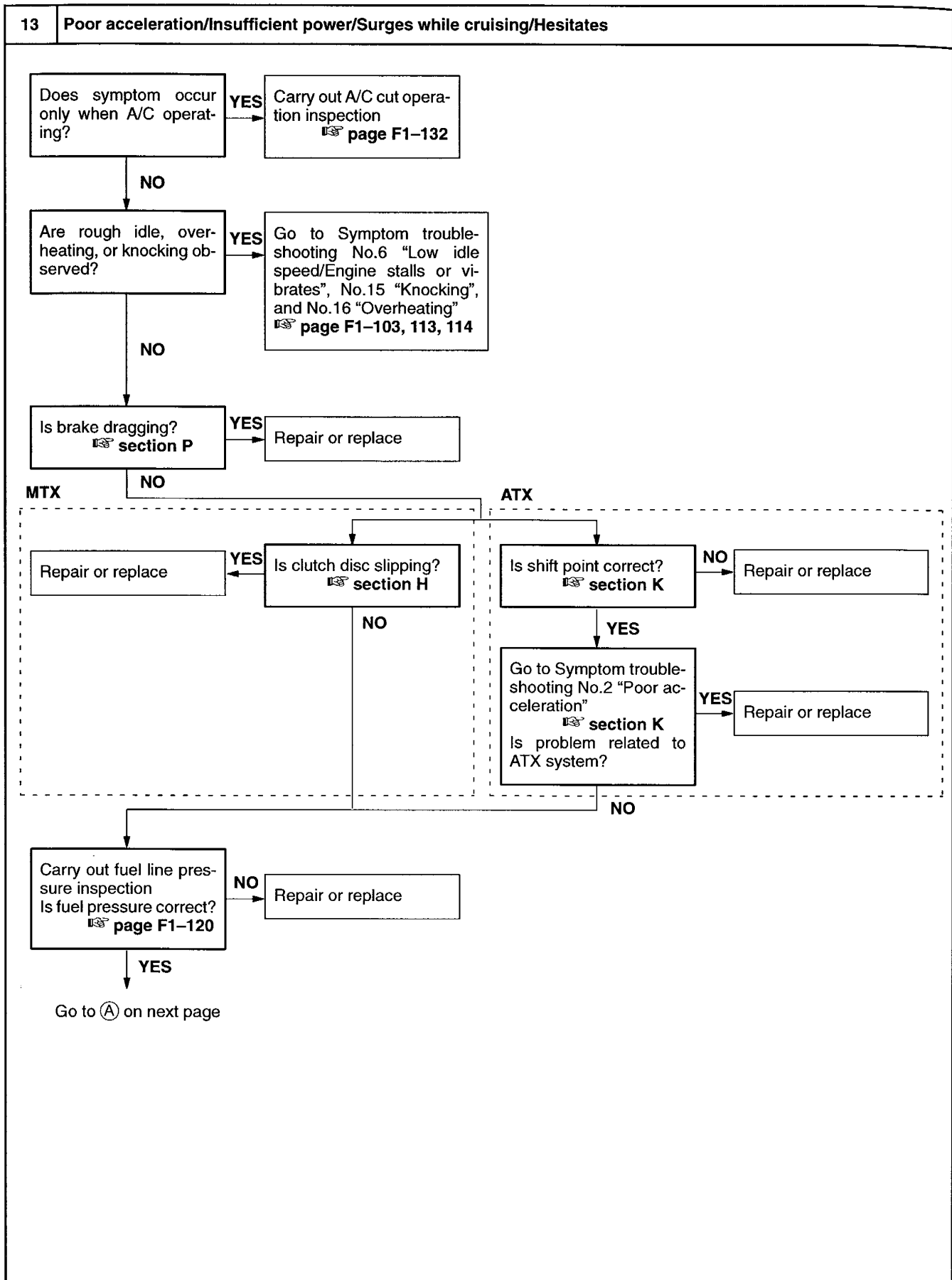

13 Poor acceleration/Insufficient power/Surges while cruising/Hesitates (Cont'd)

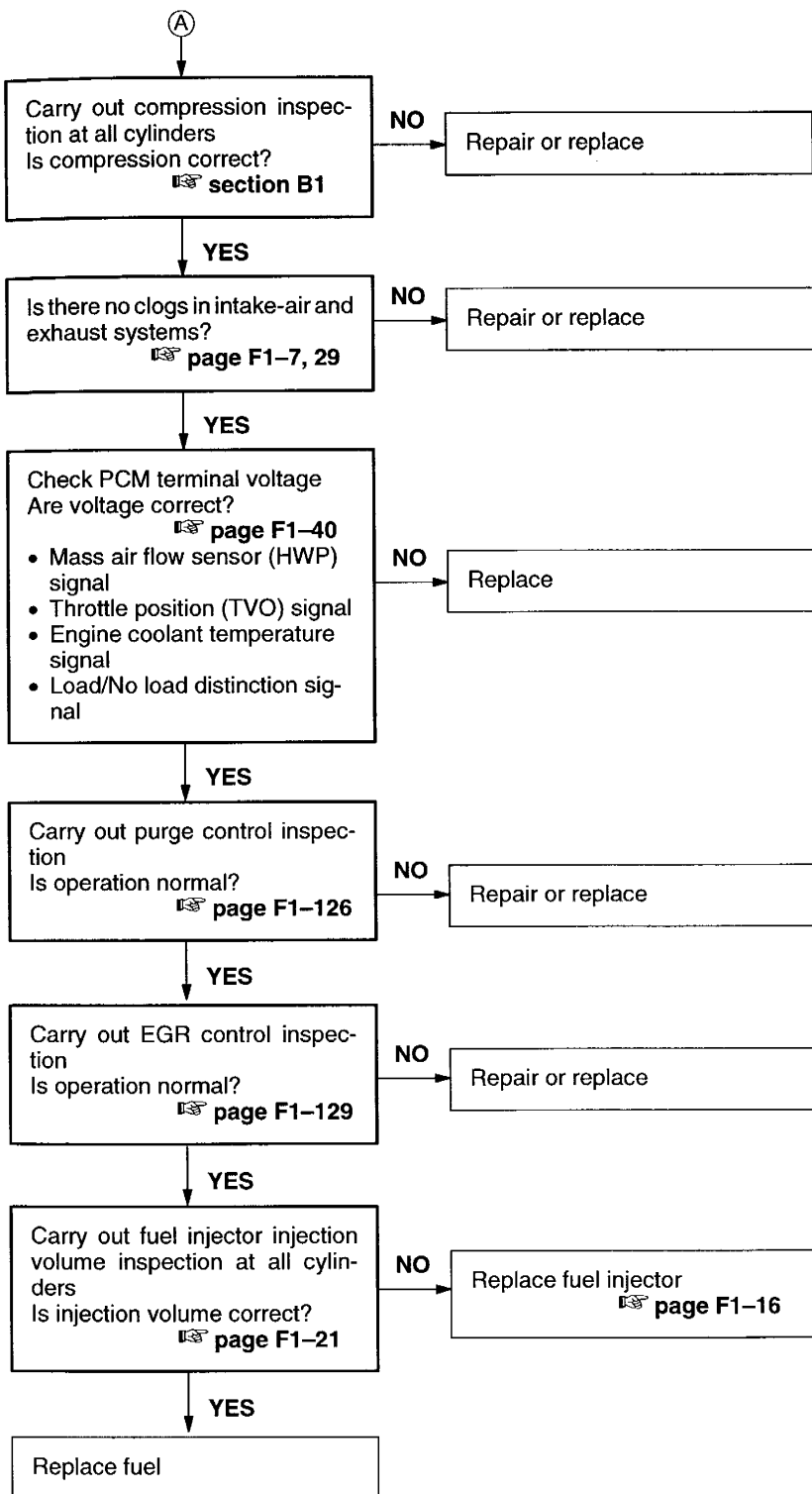

Note

- When symptom occur only when vehicle driving under heavy load condition, also check for leakage from ignition system (ignition coil, high-tension lead, spark plug)

14 Runs rough during deceleration/Backfire

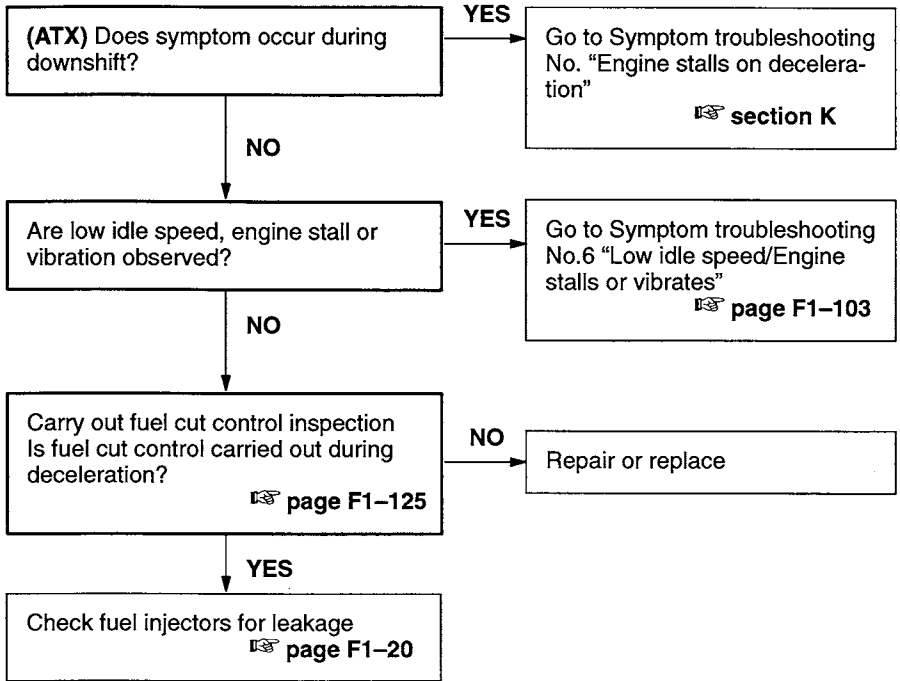

15 Knocking

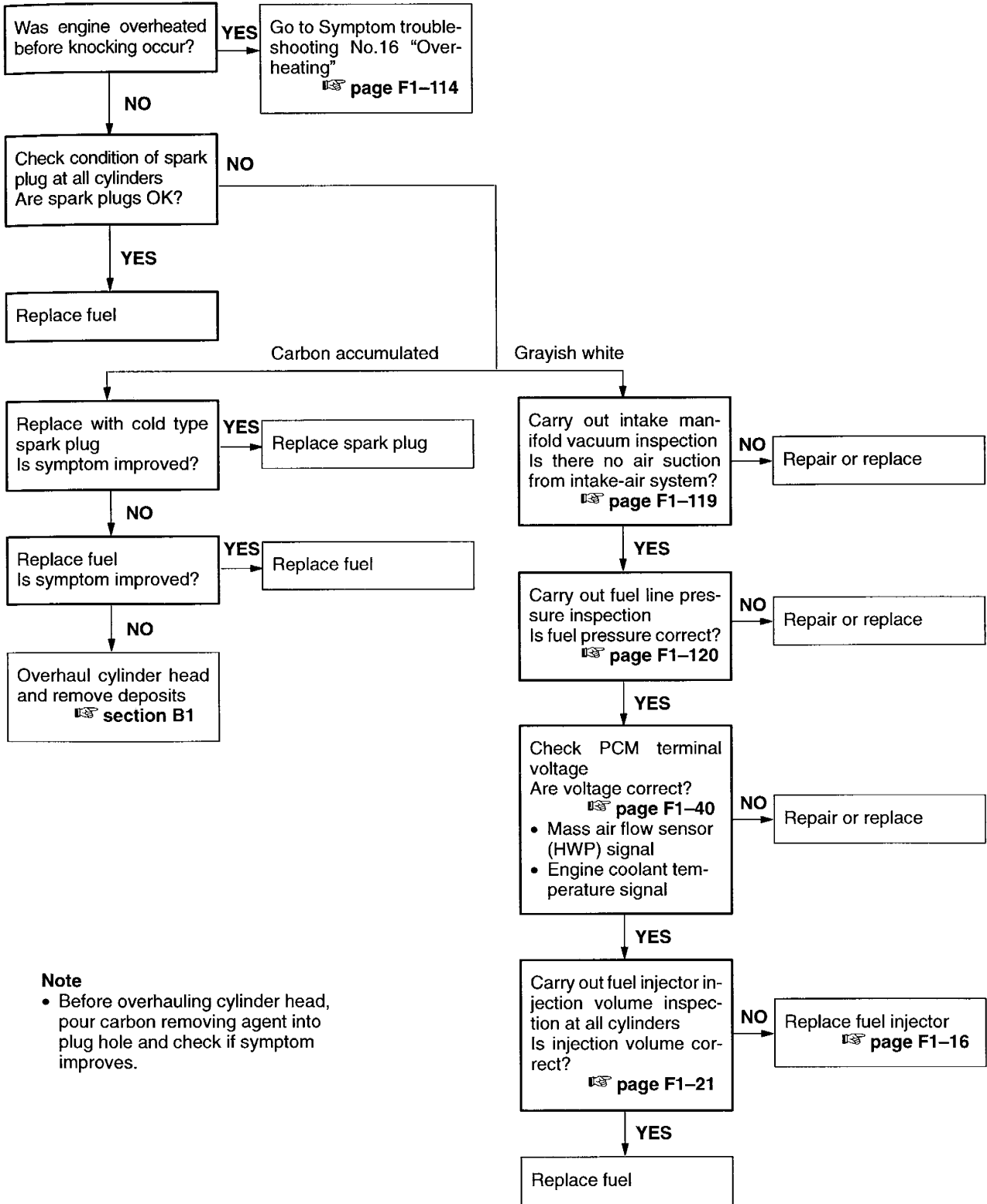

Note

- Before overhauling cylinder head, pour carbon removing agent into plug hole and check if symptom improves.

16 Overheating

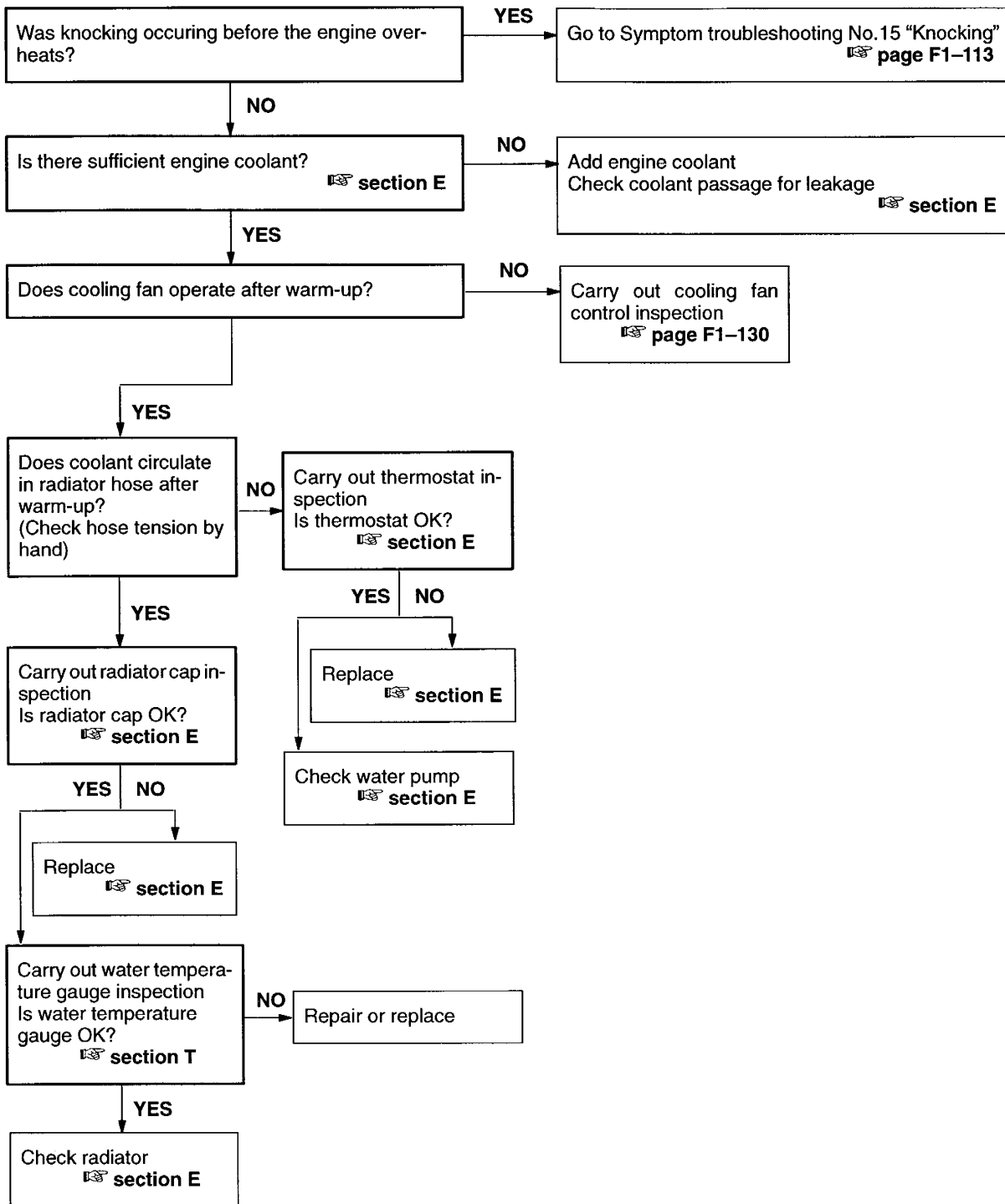

17 Poor fuel economy

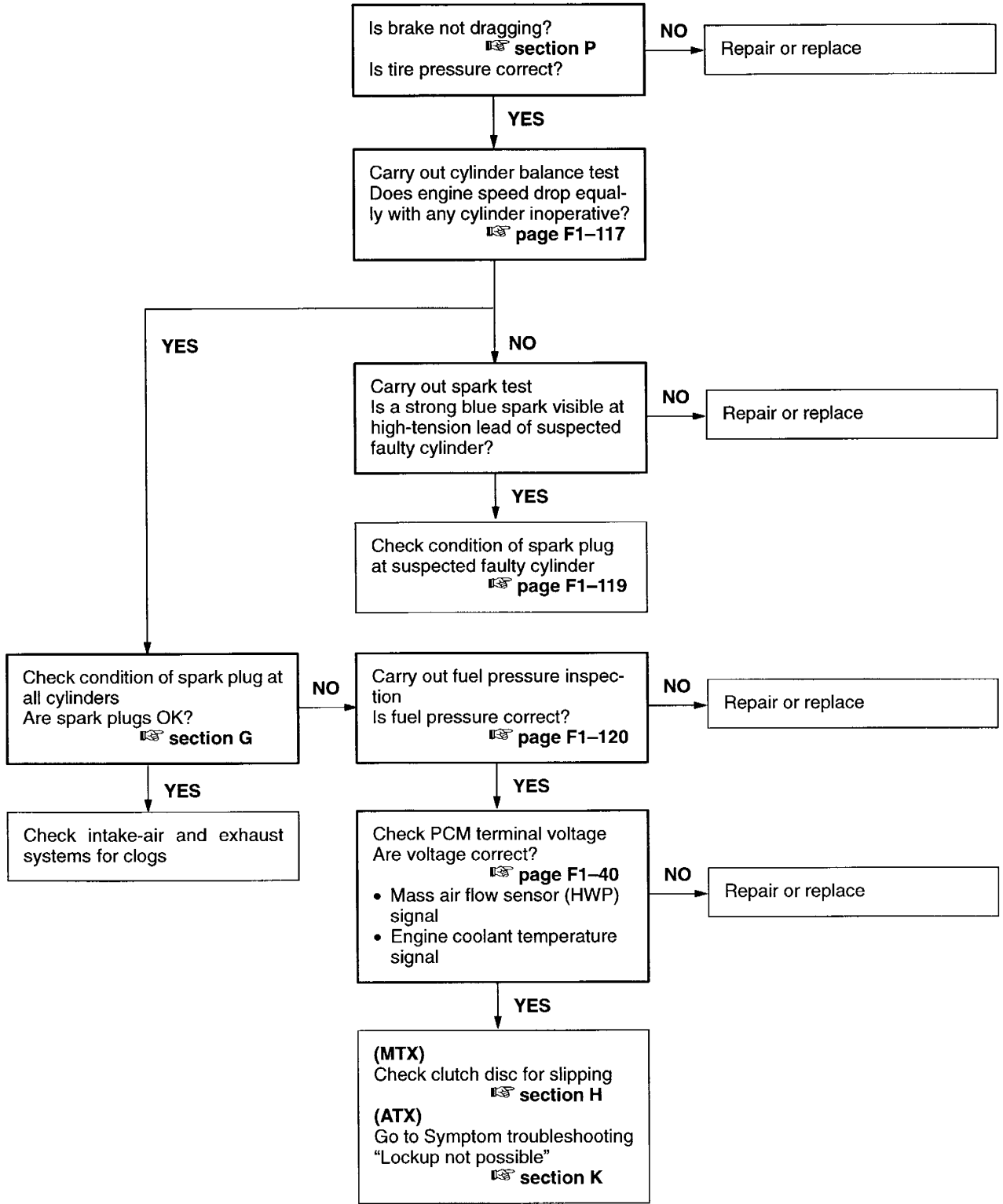

18 Fuel odor

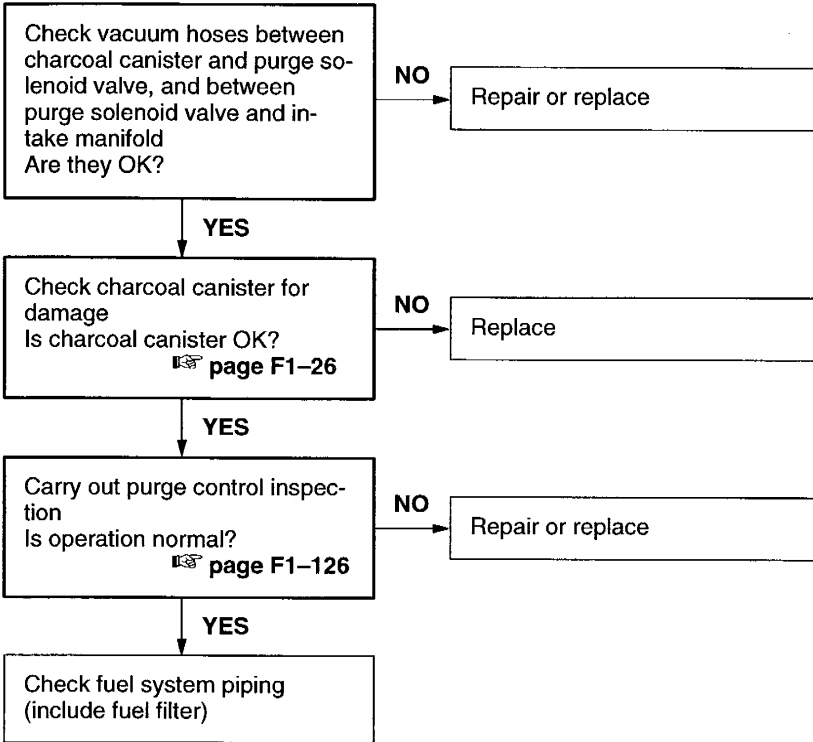

DIAGNOSTIC INSPECTION**Cylinder Balance Test****Purpose**

The purpose of the cylinder balance test is to find weak or non-contributing cylinders. In this test, the high-tension leads are disconnected one by one to shut off the ignition in each cylinder while the engine is running. The engine speed drop caused by this operation is measured and compared with each other, and the cylinder condition is judged. If all the engine speed decrease amounts are almost the same with any of the cylinder inoperative, there will be no weak or non-contributing cylinder. Engine speed different from others indicates that the corresponding cylinder is considered to be weak or non-contributing.

Warning

- **High-voltage in ignition system can cause strong electrical shock. Avoid direct contact to the vehicle body during the cylinder balance test.**
- **High-voltage spark will negatively effect the engine control. To prevent this, ground the high-tension lead and keep away from sensors and harnesses.**

Caution

- **Cylinder balance test can overheat and damage the three way catalytic converter.**

Note

- Diagnostic trouble codes (No. P0300, P0301, P0302, P0303, and P0304) will be stored in the PCM memory during the cylinder balance test. Carry out "After Repair Procedure" and erase these codes after this test. (Refer to page F1-54.)

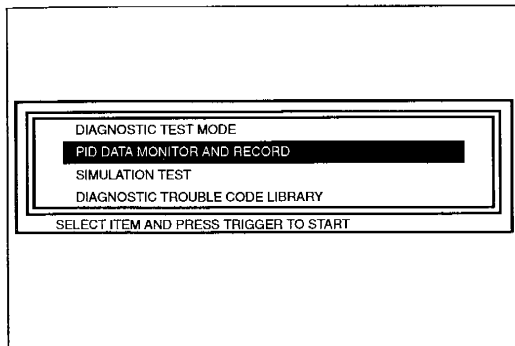
**Procedure**

1. Connect the **SSTs** (NGS) to the data link connector-2 and select the PID/DATA MONITOR AND RECORD function. (Refer to page F1-54.)
2. Select the "RPM" on the NGS display.
3. Start the engine and let it idle.
4. Disconnect each high-tension lead and measure the engine speed.
5. Compare the engine speed decrease amounts.

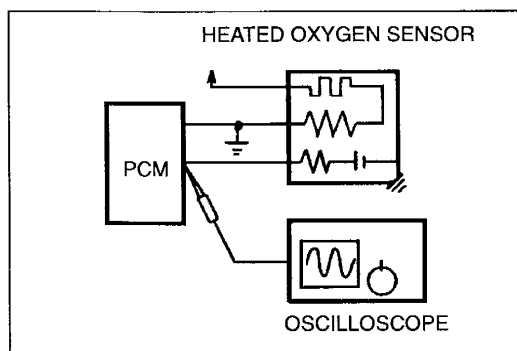
**Inspection using an oscilloscope**

1. Trouble detection by heated oxygen sensor output pulse.

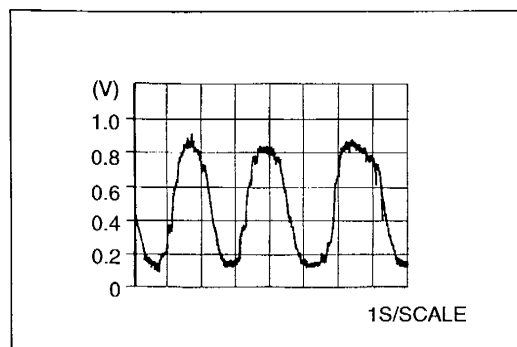

- (1) When normal Engine condition
No-load idling after warm-up

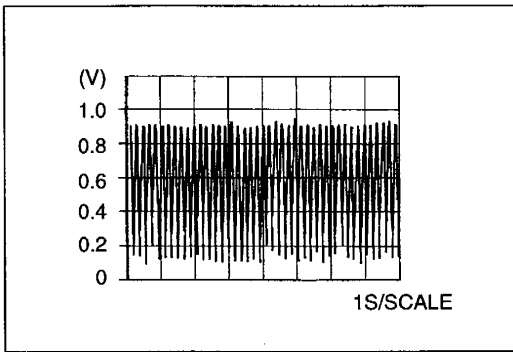

- (2) No injection in one cylinder
 Engine condition
 No-load idling after warm-up
 Pulse detected
 Pulse cycle extremely short

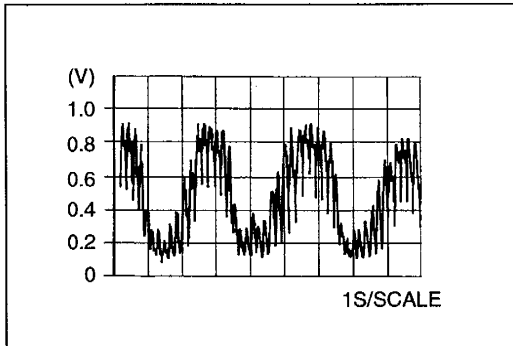

- (3) No ignition in one cylinder
 Engine condition
 No-load idling after warm-up
 Pulse detected
 Pulse cycle longer than normal pulse
 Rich spike caused by unburnt gas in misfiring cylinder observed

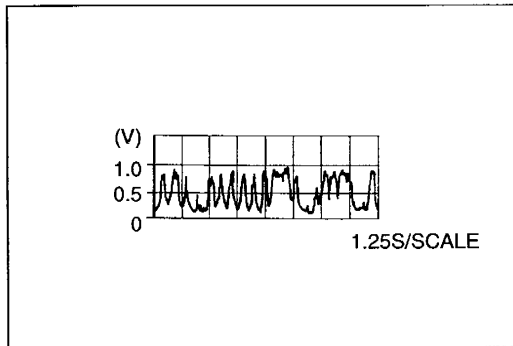

- (4) Exhaust gas flown in cylinder
 Engine condition
 No-load idling after warm-up
 Pulse detected
 Pulse width and cycle irregular

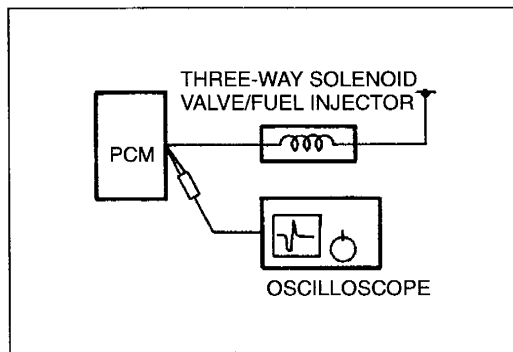

2. Plunger sticking detection using an oscilloscope.

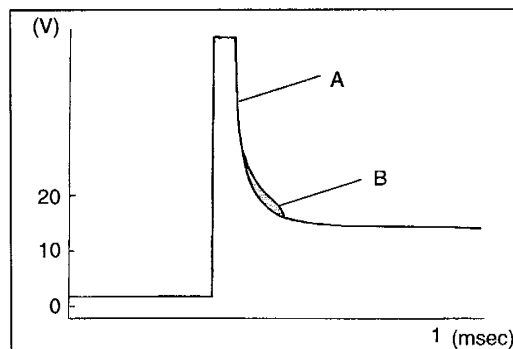

- (1) When normal
 Counter electromotive voltage A, generated when the three-way solenoid valve or the fuel injector is turned off from on, shows irregular convergence because induced electromotive voltage B, generated by the plunger return operation, is added to it.

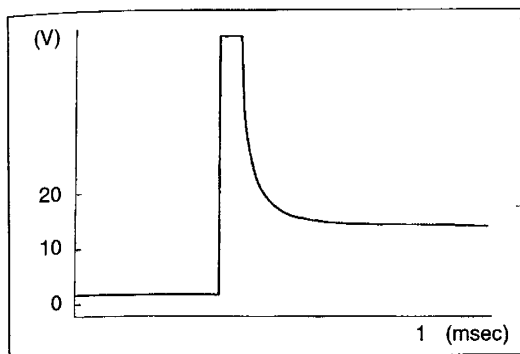

- (2) When plunger stuck
When the plunger is stuck, pulse convergence is smooth because no induced electromotive voltage B is generated.

Trouble judgement by spark plug conditions

Condition	Possible cause	page
Carbon accumulated on some spark plugs only	Fuel leakage from fuel injector Damaged spark plug (Cracked insulator) Low compression	page F1-20 section G section B1
Some spark plugs wet	Excessive fuel injection from fuel injector Damaged spark plug Low compression	page F1-20 section G section B1
Some spark plugs look grayish white	Insufficient fuel injection from fuel injector	page F1-20

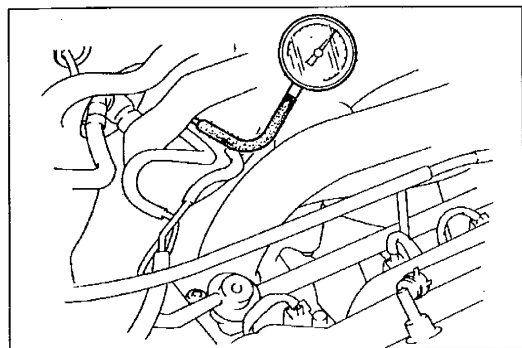

SYSTEM INSPECTION

Intake Manifold Vacuum Inspection

1. Verify that the intake-air system hoses are fitted securely.
2. Disconnect the vacuum hose from the pressure regulator and connect to vacuum gauge as shown.
3. Start the engine and let it idle.
4. Measure the intake manifold vacuum by using a vacuum gauge.

Vacuum: More than 60 kPa { 450 mmHg , 18 inHg }

5. If not as specified, check following
 - Air suction at:
 - Throttle body installation point
 - Intake manifold installation point
 - PCV valve installation point
 - Accelerator cable free play (Refer to page F1-9.)
 - Engine compression (Refer to section B1.)

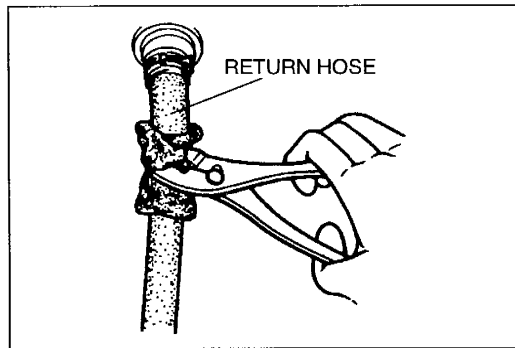
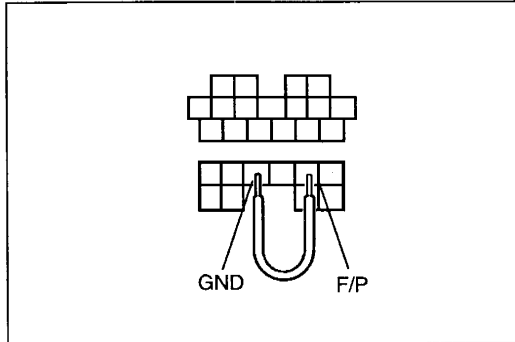
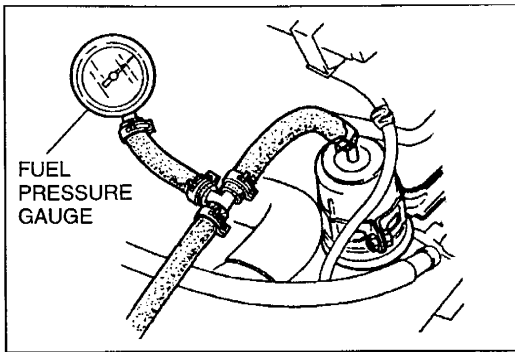

Fuel Line Pressure Inspection

Warning

- Fuel line spills and leaks are dangerous. Fuel can ignite and cause serious injuries or death and damage. Fuel can also irritate skin and eyes. To prevent this, always complete the “Fuel Line Safety Procedures” on page F1-10.

1. Disconnect the negative battery cable.
2. Connect a fuel pressure gauge between the fuel filter (high pressure side) and fuel distributor.
3. Connect the negative battery cable.
4. Connect data link connector terminals F/P and GND by using a jumper wire.
5. Turn the ignition switch to ON and measure the fuel line pressure.

Specification:

270—310 kPa { 2.7—3.2 kgf/cm² , 39—45 psi }

6. Turn off the ignition switch and disconnect the jumper wire.
7. If the pressure is higher than specified, check the fuel pump maximum pressure. (Refer to page F1-19.)
If normal, check the pressure regulator, or fuel return hose is clogged.
8. If the pressure is lower than specified, measure the fuel line pressure with pinching the return hose.
 - If the fuel line pressure quickly increases, check the pressure regulator and PRC solenoid valve. (Refer to page F1-22.)
 - If the fuel line pressure gradually increases, check the fuel pump maximum pressure. (Refer to page F1-19.)
9. If the pressure is normal, check the clogging between fuel pump and pressure regulator.

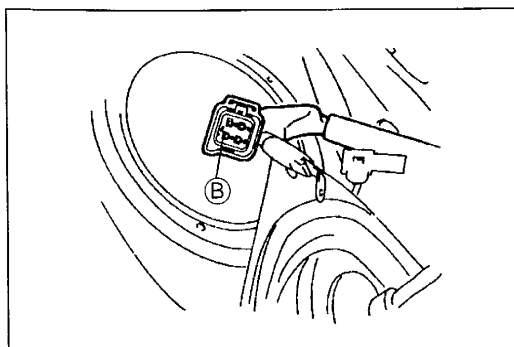
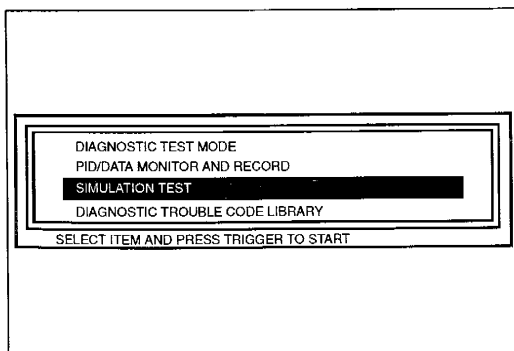
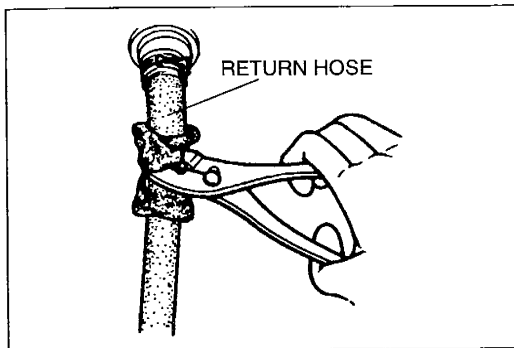
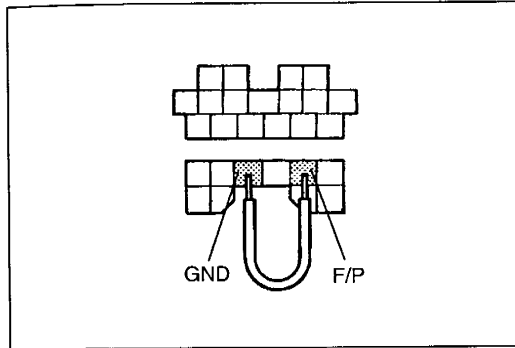
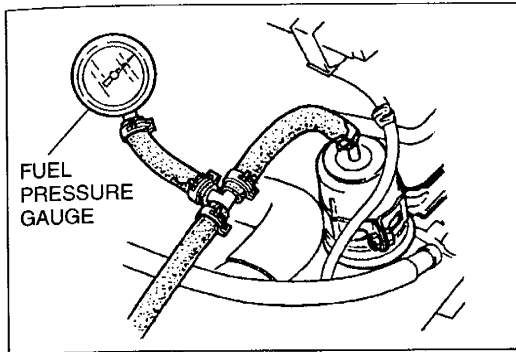

Fuel Pressure Hold Inspection

Warning

- Fuel line spills and leaks are dangerous. Fuel can ignite and cause serious injuries or death and damage. Fuel can also irritate skin and eyes. To prevent this, always complete the "Fuel Line Safety Procedures" on page F1-10.

1. Disconnect the negative battery cable.
2. Connect a fuel pressure gauge between the fuel filter (high pressure side) and fuel distributor.
3. Connect the negative battery cable.
4. Connect data link connector terminals F/P and GND by using a jumper wire.
5. Turn the ignition switch to ON for approx. 10 sec. to operate the fuel pump.
6. Turn off the ignition switch. Wait for 5 min., and measure the fuel pressure.

Specification:

More than 150 kPa { 1.5 kgf/cm² , 21 psi }

7. Disconnect the jumper wire.
8. If the pressure is lower than specified, measure the fuel line pressure with pinching the return hose.
 - If the fuel line pressure holds, replace the pressure regulator. (Refer to page F1-7.)
 - If the fuel line pressure does not hold, check the fuel pump fuel hold pressure. (Refer to page F1-19.) If the fuel pump fuel hold pressure is normal, check the fuel leaks from fuel line and fuel injector.

Fuel Pump Operation Inspection

1. Connect the **SSTs** (NGS) to the data link connector-2. (Refer to page F1-37.)
2. Remove the fuel filler cap.
3. Turn the ignition switch to ON.
4. Select the SIMULATION TEST function on the NGS display.
5. Turn the fuel pump relay from OFF to ON by using the "FP RLY". Operate the fuel pump relay and check if operation sound of the fuel pump is heard.
 - (1) If the operation sound is heard, do as follows.
 - I. Measure the voltage at terminal B of the fuel pump connector (harness side).
Voltage: Battery positive voltage (Ignition switch: ON)
 - II. If the voltage is correct, check the following.
 - Continuity of the fuel pump (Refer to page F1-19.)
 - III. If the voltage is not correct, check the following.
 - Wiring harnesses and connectors (Fuel pump relay — Fuel pump)
 - (2) If the operation sound is not heard, check the following.
 - Fuel pump relay (Refer to page F1-22.)
 - Wiring harnesses and connectors (Main relay — Fuel pump relay — PCM)

Spark Test

1. Remove the rear seat cushion. (Refer to section S.)
2. Disconnect the fuel pump connector. (Refer to page F1-13.)
3. Verify that each high-tension lead and connector is connected properly.
4. Inspect the ignition system in the following procedure.

Warning

- **High voltage in the ignition system can cause strong electrical shock. Avoid direct contact to the vehicle body during the following spark test.**

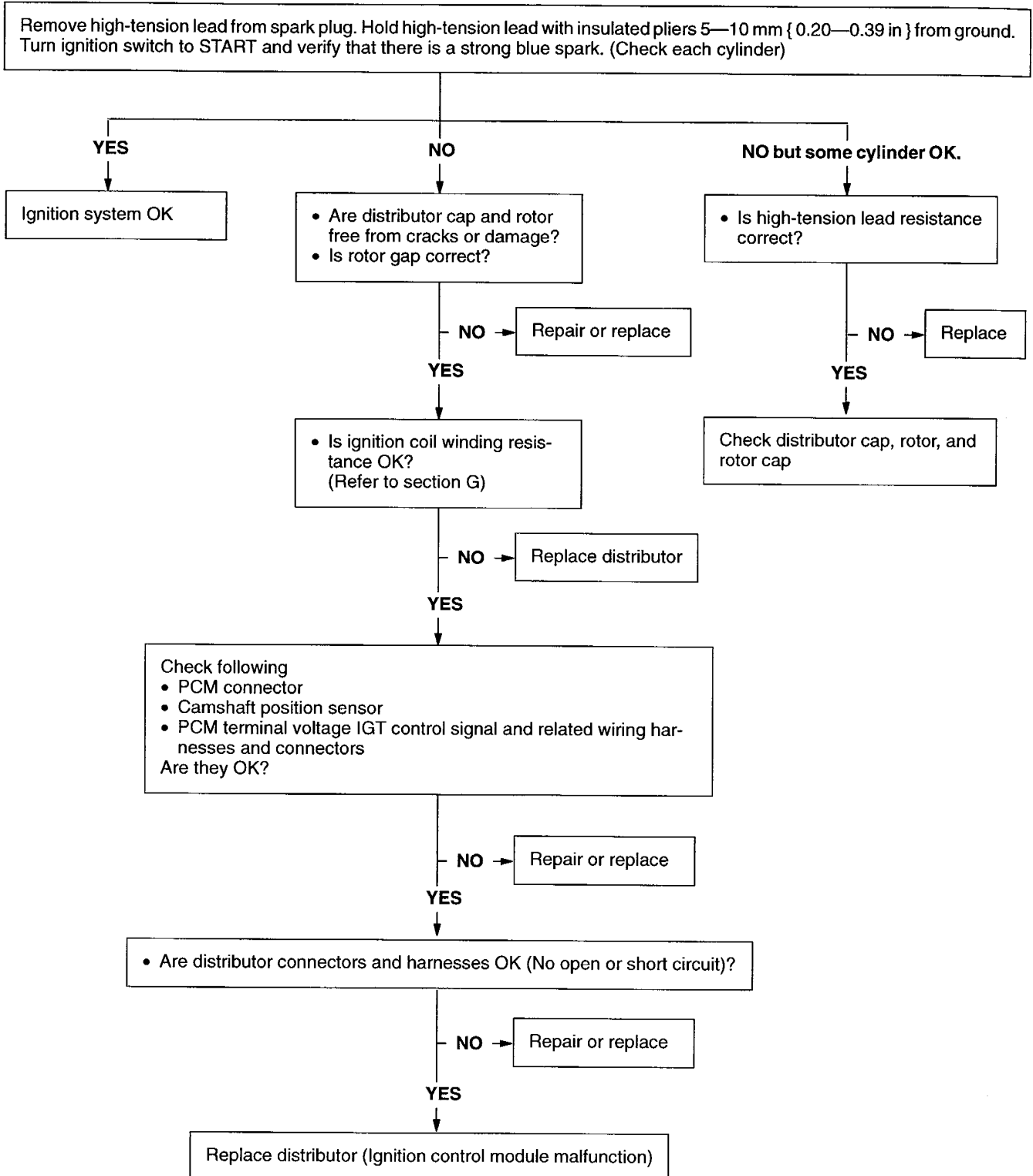

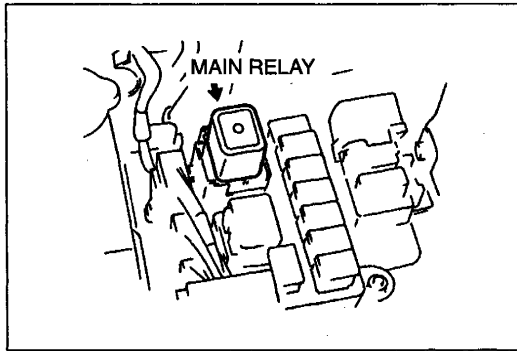

Main Relay Operation Inspection

1. Verify that the main relay clicks when the ignition switch is turned to ON and OFF.
2. If there is no operation sound, inspect the following.
 - Main relay (Refer to page F1-53.)
 - Harness and connector between ignition switch and main relay.

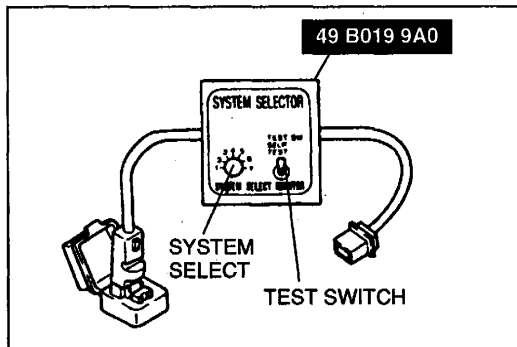

BAC Valve Operation Inspection

1. Connect the **SST** (System Selector) to the data link connector.
2. Set switch A to position 1.
3. Set the test switch to SELF TEST.
4. Connect the **SSTs** (NGS) to the data link connector-2. (Refer to page F1-37.)
5. Select the PID/DATA MONITOR AND RECORD function.
6. Verify that the engine is cold condition, and start the engine.
7. Select the "RPM" on the NGS display.
8. Verify that the engine speed decreases as the engine warms up.
9. Disconnect the **SST** (System Selector).
10. If the engine speed will not decrease or decreases slowly, check the water hose connected to BAC valve for leakage and clogs. (Refer to section E.)
11. If the water hose is OK, inspect the following.
 - Air valve (Refer to page F1-8.)
 - IAC valve (Refer to page F1-8.)

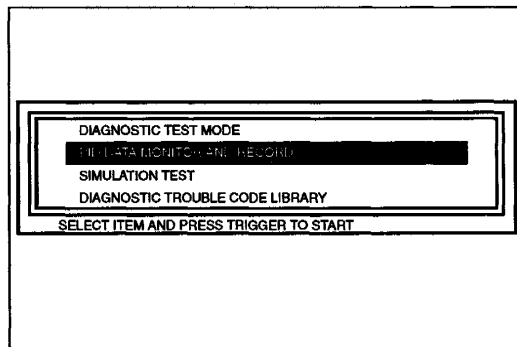

Fuel Injector Operation Inspection

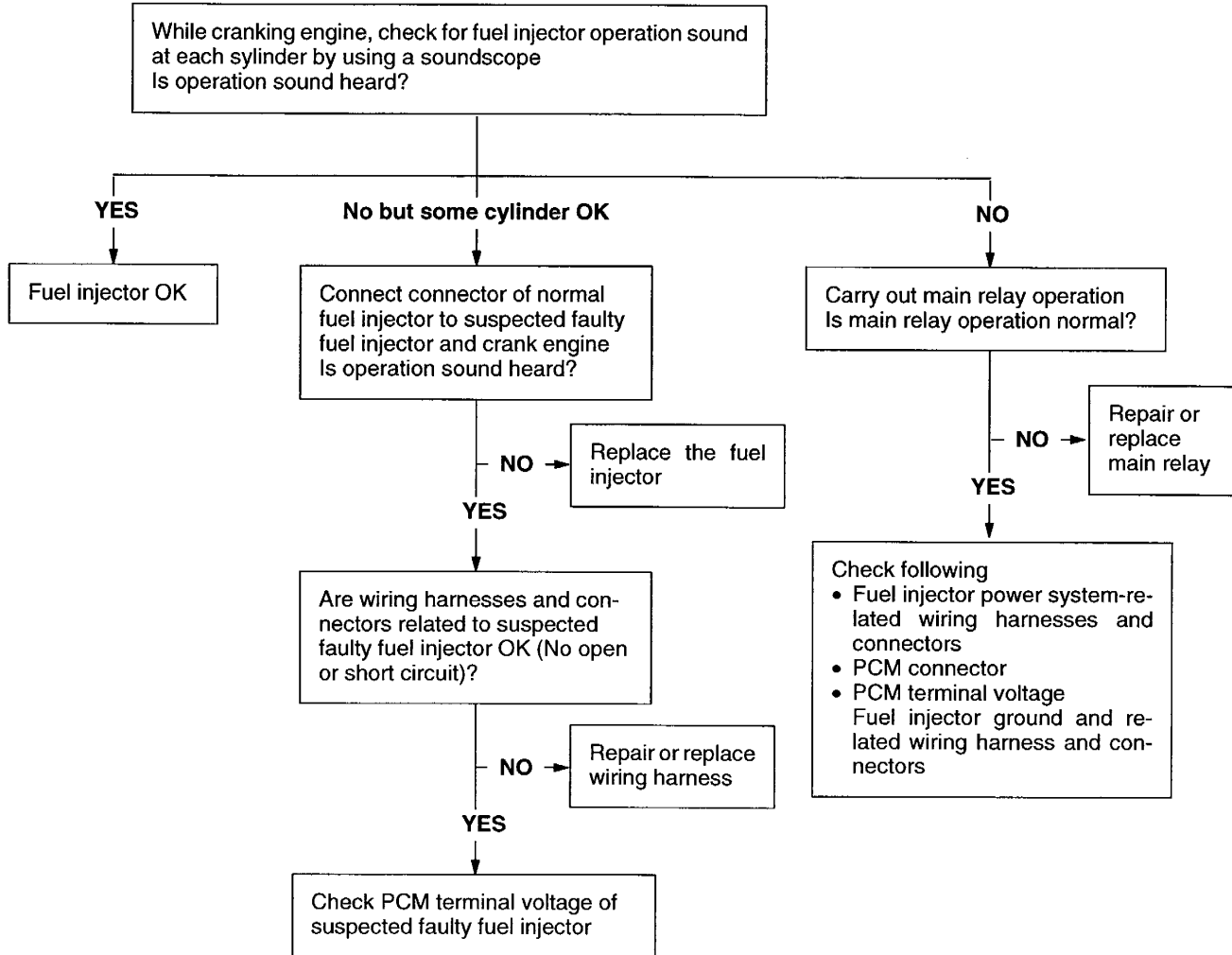

Fuel Cut Control Inspection

1. Warm up the engine to normal operating temperature.
2. Turn off the A/C switch.
3. Connect the **SSTs** (NGS) to the data link connector-2. (Refer to page F1-37.)
4. Select the PID/DATA MONITOR AND RECORD function on the NGS display.
5. Select the "RPM".
6. Using a soundscope, listen for the fuel injector operation sound at all cylinders.

Open throttle valve and increase engine speed to 3,000 rpm. Quickly close throttle valve and check for fuel injector operation sound. Does sound stop when throttle valve is closed and start again when engine speed dropped below 1,900 rpm?

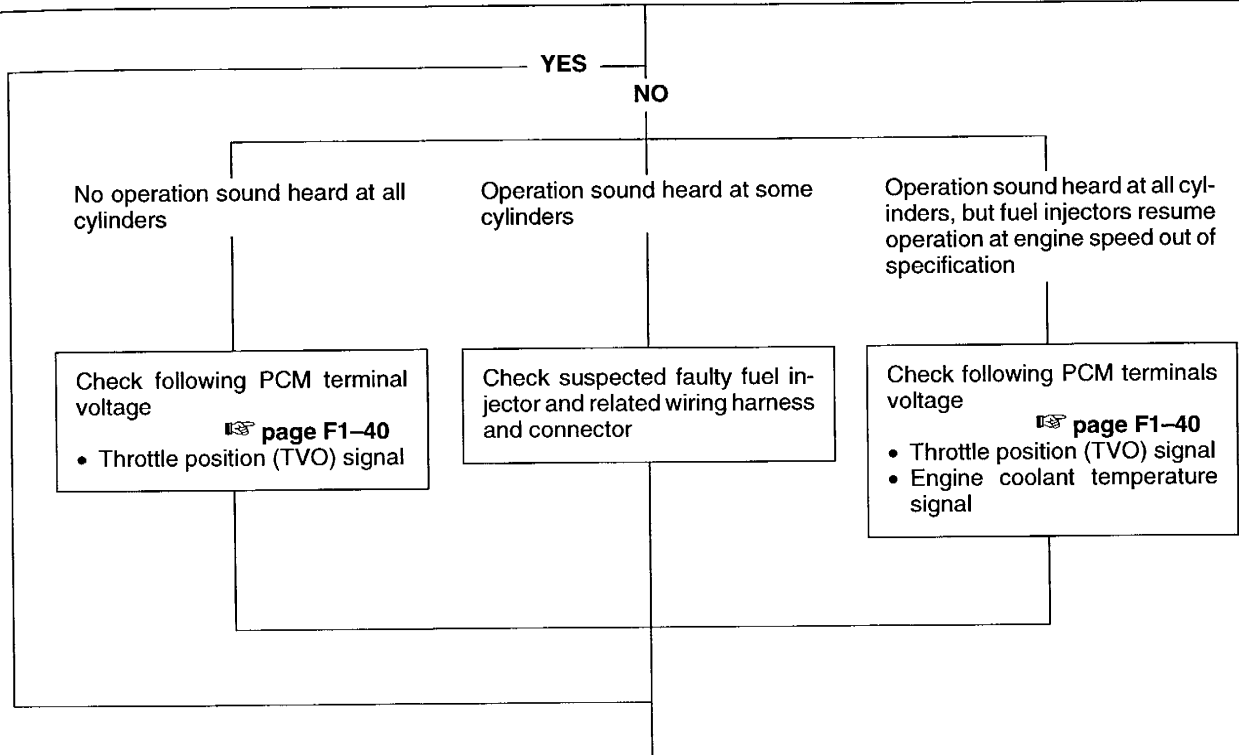

Place a vehicle on chassis roller. Depress accelerator pedal and increase engine speed to 2,000 rpm. Release accelerator pedal (brake pedal not depressed) and check for fuel injector operation sound by using soundscope or oscilloscope at all cylinders. Does sound stop when accelerator pedal is released and start again when engine speed dropped below 1,100 rpm?

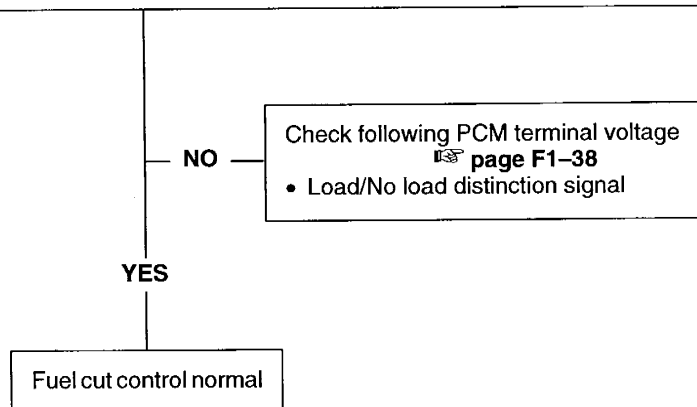

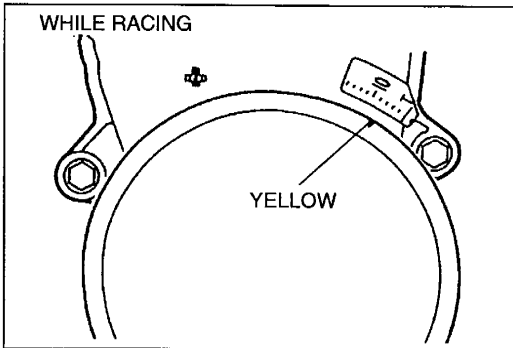
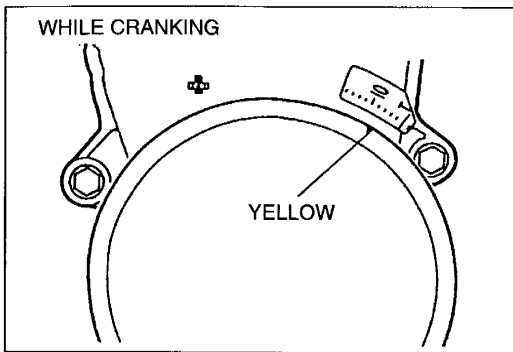

Ignition Timing Control Inspection

1. Connect a timing light to the engine.
2. Crank the engine.
3. Verify that the timing mark (yellow) on the crankshaft pulley and the mark on the timing belt cover are aligned.

Specification: BTDC 6—8°

4. If not as specified, loosen the lock bolt and adjust by turning the distributor.
5. If adjustment by turning distributor is not possible, check the following.
 - PCM terminal voltage
 - IGT control signal and related wiring harnesses and connectors.
 - Camshaft position sensor (Refer to page F1-44.)
 - Ignition control module (Refer to section G) and related wiring harnesses and connectors.
6. Warm up the engine to normal operation temperature.
7. Verify that the ignition timing is correct. (Refer to page F1-2.)
8. Increase the engine speed and verify that the ignition timing advances accordingly.
9. If not, check the following.
 - Mass air flow sensor (Refer to page F1-43.)

Purge Control Inspection

1. Start and warm up the engine to normal operating temperature.
2. Let the engine idle.
3. Disconnect the vacuum hose between the purge solenoid valve and the charcoal canister.
4. Put a finger to the purge solenoid valve and verify that there is no vacuum applied.
5. If there is vacuum, do as follows.
 - (1) Connect the **SSTs** (NGS) to the data link connector-2. (Refer to page F1-37.)
 - (2) Verify that diagnostic trouble code No. P0443 is not displayed. If code No. P0443 is shown, carry out troubleshooting of the code No. P0443. (Refer to page F1-75.)
 - (3) If diagnostic trouble codes are not shown, check the following.
 - Purge solenoid valve (Refer to page F1-27.)
6. Reconnect the vacuum hose.
7. Connect the **SSTs** (NGS) to the data link connector-2.
8. Select the SIMULATION TEST function on the NGS display.
9. Increase the duty value of the purge solenoid valve from 0% to 100% by using the "PRGV". Operate the purge solenoid valve and check if the idle condition changes.

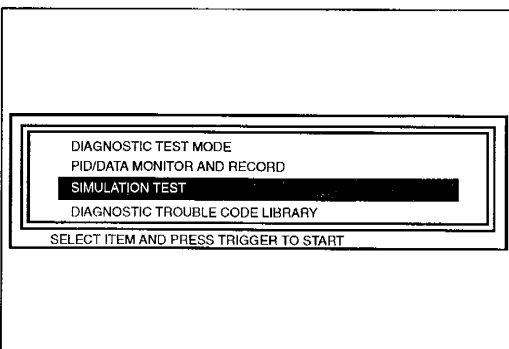

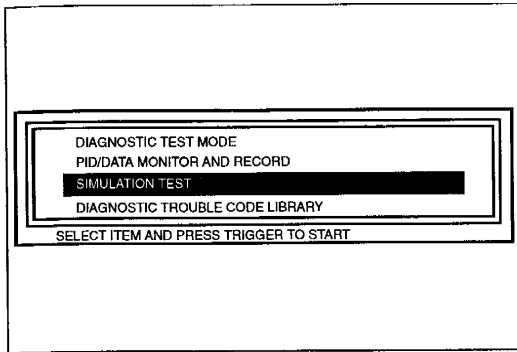

10. If the condition does not change, do as follows.
 - (1) Turn the ignition switch to ON.
 - (2) Verify that diagnostic trouble code No. P0443 is not displayed. If code No. P0443 is shown, carry out troubleshooting of the code No. P0443. (Refer to page F1-75.)
 - (3) Select the SIMULATION TEST function on the NGS display.
 - (4) Increase duty value of the purge solenoid valve from 0% to 100% by using the "PRGV". Operate the purge solenoid valve and check if the operation sound of the valve is heard.

- I. If the operation sound is heard, check the following.
 - Loose or damaged vacuum hose
- II. If the operation sound is not heard, check the following.
 - Purge solenoid valve (Refer to page F1-27.)

Idle Air Control Inspection

1. Start the engine and run it at idle.
2. Disconnect the IAC valve connector and verify that the engine rotation changes.
3. If the engine condition will not change, do as follows.
 - (1) Connect the **SSTs** (NGS) to the data link connector-2. (Refer to page F1-37.)
 - (2) Verify that diagnostic trouble code No. P0505 is not displayed. If code No. P0505 is shown, carry out troubleshooting of the code No. P0505.
 - (3) Select the SIMULATION TEST function on the NGS display.
 - (4) Change the duty value of the IAC valve to 100% by using the "IACV" and verify that the idle speed increases.
 - a. If the idle speed increases, replace the PCM. (Refer to page F1-35.)
 - b. If the idle speed does not change. Replace the IAC valve. (Refer to page F1-7.)
4. Warm up the engine to normal operating temperature and run it at idle.
5. Turn the electrical loads ON and verify that the engine speed is within the specification.

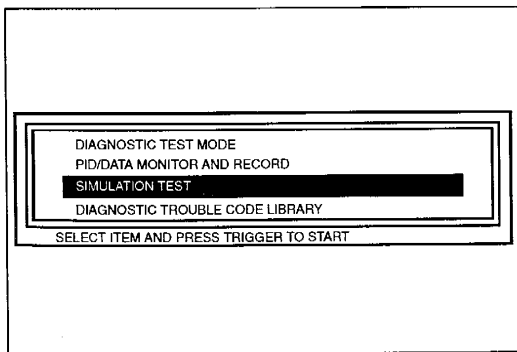

Engine speed (rpm)

Load condition	Idle speed (rpm)	
	MTX	ATX
Fan switch ON at 2nd or higher	650—750	700—800
Headlight switch ON		
Rear window defroster switch ON		
P/S ON	700—800	
A/C ON		

Note

- Excludes temporary idle speed drop just after the electrical loads are turned on.

6. If not as specified, check the related switches and wiring harnesses.

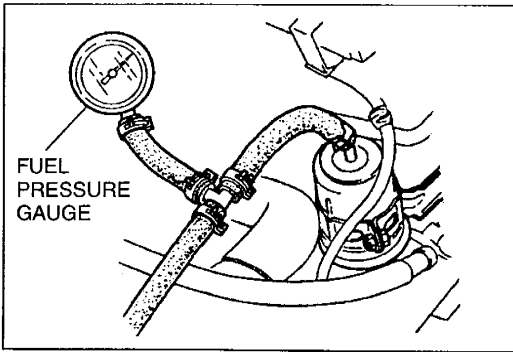

Pressure Regulator Control Inspection System Inspection

Warning

- Fuel line spills and leaks are dangerous. Fuel can ignite and cause serious injuries or death and damage. Fuel can also irritate skin and eyes. To prevent this, always complete the "Fuel Line Safety Procedures". (Refer to page F1-10.)

1. Install the fuel pressure gauge.
2. Measure the fuel pressure under the following conditions.

Specifications

	Fuel pressure kPa { kgf/cm ² , psi }		
Idling	216—264 { 2.2—2.7 , 32—38 }	216—264 { 2.2—2.7 , 32—38 }	More than 284 { 2.9 , 41.2 }
During 150 sec. of hot start	More than 284 { 2.9 , 41.2 }		
After 150 sec. of hot start	216—264 { 2.2—2.7 , 32—38 }		
Judgement	Normal	Not normal (Perform Inspection 1)	Not normal (Perform Inspection 2)

3. If the fuel pressure is not within the specification. Carry out either Inspection 1 or Inspection 2.

Inspection 1

1. Stop the engine.
2. Connect the **SSTs** (NGS) to the data link connector-2.
3. Verify that diagnostic trouble code No. P1250 is not displayed. If code No. P1250 is shown. Carry out troubleshooting of the code No. P1250. (Refer to page F1-82.)
4. Start the engine and run it at idle.
5. Select the SIMULATION TEST function on the NGS display.
6. Turn the PRC solenoid valve from OFF to ON by using the "PRCV" and check if the fuel pressure changes.

- (1) If the pressure changes, check the following
 - PCM terminal voltage (Refer to page F1-40.)
 - Engine coolant temperature signal
 - Intake air temperature signal
 - Throttle position signal
- (2) If the pressure does not change, do as follows.
 - I. Stop the engine.
 - II. Turn the ignition switch to ON.
 - III. Turn the PRC solenoid valve from OFF to ON by using the "PRCV" and check if the operation sound of the valve is heard.
 - a. If the operation sound is heard, check the following.
 - Pressure regulator (Refer to page F1-21.)
 - b. If the operation sound is not heard, check the following.
 - PRC solenoid valve (Refer to page F1-22.)

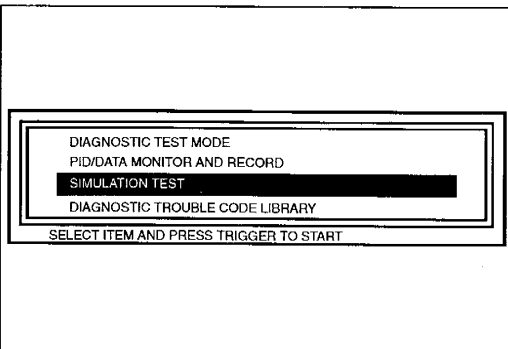

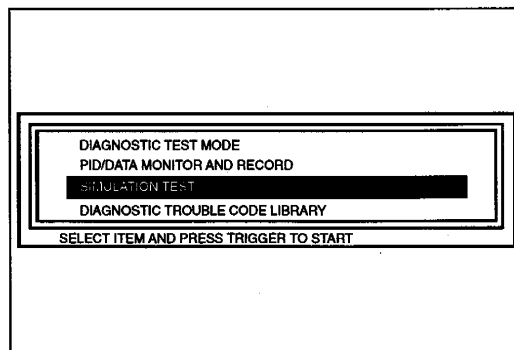
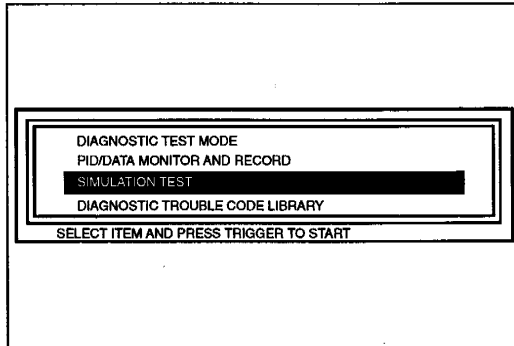
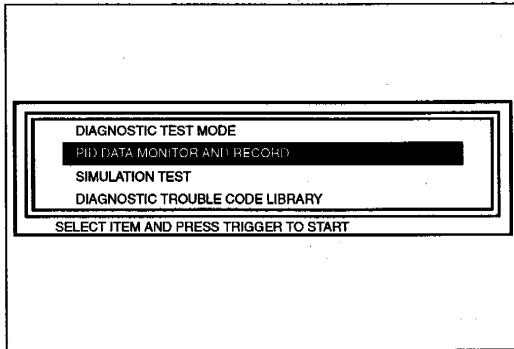

Inspection 2

1. Stop the engine.
2. Connect the **SSTs** (NGS) to the data link connector-2.
3. Verify that diagnostic trouble code No. P1250 is not displayed. If code No. P1250 is shown. Carry out troubleshooting of the code No. (Refer to page F1-82.)
4. Select the PID/DATA MONITOR AND RECORD function on the NGS display.
5. Select the "PRCV" and verify that the PRC solenoid valve is OFF.
6. If the PRC solenoid valve is ON, check the following.
 - PCM terminal voltage (Refer to page F1-40.)
 - Engine coolant temperature signal
 - Intake air temperature signal
7. Select the SIMULATION TEST function on the NGS display.
8. Turn the PRC solenoid valve from OFF to ON using the "PRCV" and check if the operation sound of the valve is heard.
 - (1) If the operation sound is heard, check the following.
 - Loose or damaged vacuum hose between the pressure regulator, PRC solenoid valve, and intake manifold.
 - (2) If the operation sound is not heard, check the following.
 - PRC solenoid valve (Refer to page F1-22.)

EGR Control Inspection

1. Connect the **SSTs** (NGS) to the data link connector-2.
2. Start the engine and let it idle.
3. Select the SIMULATION TEST function on the NGS display.
4. Increase the duty value of EGR solenoid valve (vacuum) from 0% to 100% by using the "EGRVAC". Operate the EGR solenoid valve (vacuum) and check if the engine speed becomes unstable or the engine stalls.
5. If the engine speed will not change, stop the engine and do as follows.
 - (1) Turn the ignition switch to ON.
 - (2) Verify that diagnostic trouble code No. P1485, P1486 is not displayed. If code No. P1485, P1486 is shown, carry out troubleshooting of the code No. P1485, P1486. (Refer to page F1-87.)
 - (3) Increase the duty value of the EGR solenoid valve (vacuum) from 0% to 100% by using the "EGRVAC". Operate the EGR solenoid valve and check if operation sound of the valve is heard.
 - I. If the operation sound is heard, check the following.
 - Loose or damaged vacuum hose
 - EGR valve (Refer to page F1-27.)
 - EGR solenoid valve (vent)
(Refer to page F1-28.)
 - II. If the operation sound is not heard, check the following.
 - EGR solenoid valve (vacuum)
(Refer to page F1-28.)

NGS DISPLAY

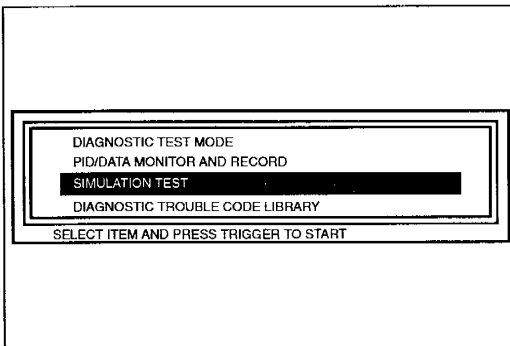
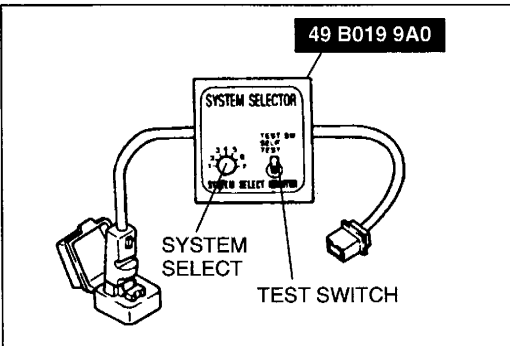
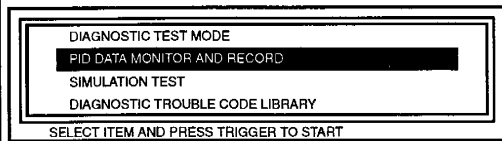
**Cooling Fan Control Inspection**

1. Verify that the engine is cold.
2. Turn the ignition switch to ON.
3. Verify that the cooling fan is not operating.
4. If the cooling fan is operating, do as follows.
 - (1) Connect the **SSTs** (NGS) to the data link connector-2. (Refer to page F2-37.)
 - (2) Select the PID/DATA MONITOR AND RECORD function on the NGS display.
 - (3) Select the "FANC" and verify that the cooling fan control signal is OFF.
 - I. If the cooling fan control signal is ON, check the following.
 - PCM terminal voltage (Refer to page F1-40.)
 - Engine coolant temperature signal
 - II. If the cooling fan control signal is OFF, check the following.
 - Cooling fan relay (Refer to page section E.)
 - Short circuit in wiring harnesses and connectors (Main relay — Cooling fan relay — PCM)
5. Connect the **SST** (System Selector) to the data link connector.
6. Set switch A to position 1.
7. Set the test switch to SELF TEST.
8. Depress the accelerator pedal and verify that the cooling fan operates.
9. If the cooling fan does not operate, do as follows.
 - (1) Connect the **SSTs** (NGS) to the data link connector-2.
 - (2) Select the SIMULATION TEST function on the NGS display.
 - (3) Turn the cooling fan relay from OFF to ON by using the "FANC" and check for the cooling fan operation.
 - I. If the cooling fan operates, check the following.
 - PCM terminal voltage (Refer to page F1-38.)
 - Test mode signal
 - Throttle position signal
 - II. If the cooling fan does not operate, do as follows.
 - a. Turn the cooling fan relay from OFF to ON by using the simulation function. Operate the cooling fan relay and check if the operation sound of the relay is heard.
 - b. If the operation sound is heard, check the following.
 - Wiring harnesses and connectors (Cooling fan relay — Cooling fan motor)
 - Cooling fan motor (Refer to section E.)
 - c. If the operation sound is not heard, check the following.
 - Cooling fan relay (Refer to section E.)
 - Open circuit in wiring harnesses and connectors (Main relay — Cooling fan relay — PCM)

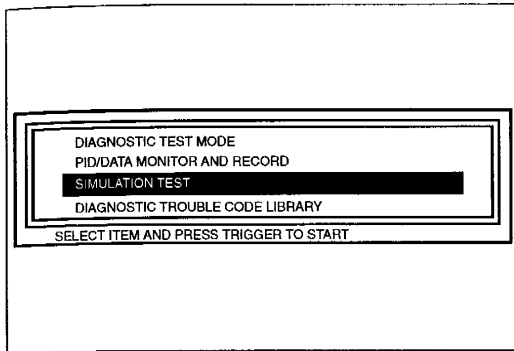

Condenser Fan Relay

1. Verify that engine is cold and the A/C switch and fan switch are OFF.
2. Start the engine and let it idle.
3. Verify that the condenser fan is not operating.
4. If the condenser fan is operating, check the short circuit in wiring between condenser fan relay and PCM terminal 1A.
5. Turn the A/C switch and fan switch on.
6. Verify that the condenser fan is operating.
7. Turn the A/C switch and fan switch off.
8. If the condenser fan does not operate, do as follows
 - (1) Connect the **SSTs** (NGS) to the data link connector-2. (Refer to page F1-37.)
 - (2) Select the SIMULATION TEST function on the NGS display.
 - (3) Turn the condenser fan relay from OFF to ON by using the "FANN" and check for the condenser fan operation.
 - I. If the condenser fan operates, check the following.
 - PCM terminal voltage (Refer to page F1-38.)
 - A/C signal
 - II. If the condenser fan does not operate, do as follows.
 - a. Turn the condenser fan relay from OFF to ON by using the simulation function. Operate the condenser fan relay and check if the operation sound of the relay is heard.
 - b. If the operation sound is heard, check the following.
 - Wiring harness and connectors (Condenser fan relay — Condenser fan motor)
 - Condenser fan motor (Refer to section U.)
 - c. If the operation sound is not heard, check the following.
 - Condenser fan relay (Refer to section U.)
 - Open circuit in wiring harness and connectors (Main relay — Condenser fan relay — PCM)

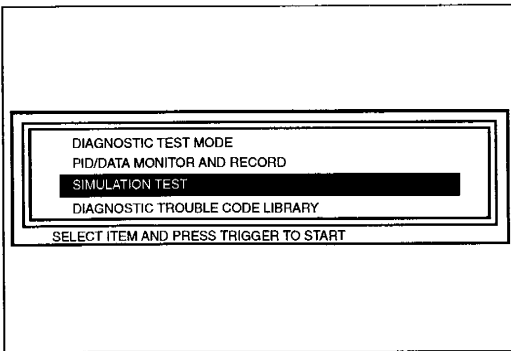

A/C Cut-off Control Inspection

1. Start the engine and let it idle.
2. Turn the A/C switch and the fan switch ON.
3. Fully open the throttle valve. Then 3—6 seconds after, check if the operation sound of the A/C compressor electromagnetic clutch is heard.
4. If the operation sound is not heard, do as follows.
 - (1) Connect the **SSTs** (NGS) to the data link connector-2. (Refer to page F1-37.)
 - (2) Select the SIMULATION TEST function on the NGS display.
 - (3) Turn the A/C relay from OFF to ON by using the "A/C RLY" function and check for the operation sound of the relay.
 - I. If the operation sound is heard, check the following.
 - PCM terminal voltage (Refer to page F1-38.)
 - Load/no load judgement signal
 - Throttle position signal
 - II. If the operation sound is not heard, check the following.
 - A/C relay (Refer to section U.)
 - Open circuit in wiring harnesses and connectors (Main relay — A/C relay — PCM)

Before beginning any service procedure, refer to section T1 of this manual for air bag system service warnings.



FUEL AND EMISSION CONTROL SYSTEMS (BP)

F2

ENGINE TUNE-UP	F2- 2	CONTROL SYSTEM	F2- 34
PREPARATION	F2- 2	PREPARATION	F2- 34
ADJUSTMENT	F2- 2	COMPONENT PARTS	F2- 35
INTAKE-AIR SYSTEM	F2- 5	POWERTRAIN CONTROL MODULE	
COMPONENT PARTS	F2- 5	(PCM)	F2- 36
AIR VALVE	F2- 8	MASS AIR FLOW SENSOR	F2- 44
IDLE AIR CONTROL VALVE	F2- 8	CAMSHAFT POSITION SENSOR .	F2- 45
SHUTTER VALVE ACTUATOR	F2- 8	CRANKSHAFT POSITION	
VACUUM CHAMBER	F2- 9	SENSOR	F2- 45
VICS SOLENOID VALVE	F2- 9	THROTTLE POSITION SENSOR .	F2- 46
ACCELERATOR PEDAL	F2-10	ENGINE COOLANT TEMPERATURE	
ACCELERATOR CABLE	F2-10	SENSOR	F2- 48
FUEL SYSTEM	F2-11	HEATED OXYGEN SENSOR	F2- 48
PREPARATION	F2-11	EGR VALVE POSITION SENSOR .	F2- 49
PRECAUTION	F2-11	EGR BOOST SENSOR	F2- 51
COMPONENT PARTS	F2-12	FUEL TANK PRESSURE SENSOR	F2- 51
FUEL PUMP	F2-21	CLUTCH SWITCH	F2- 52
FUEL INJECTOR	F2-22	NEUTRAL SWITCH	F2- 52
PRESSURE REGULATOR	F2-23	POWER STEERING PRESSURE	
PRC SOLENOID VALVE	F2-24	SWITCH	F2- 53
FUEL PUMP RELAY	F2-24	MAIN RELAY	F2- 53
EXHAUST SYSTEM	F2-25	ON-BOARD DIAGNOSTIC SYSTEM	F2- 54
COMPONENT PARTS	F2-25	PREPARATION	F2- 54
EMISSION SYSTEM	F2-28	DIAGNOSTIC TROUBLE CODE	
COMPONENT PARTS	F2-28	NUMBER	F2- 54
ROLLOVER VALVE	F2-30	TROUBLESHOOTING	F2- 92
CHECK VALVE	F2-31	USING THIS SECTION	F2- 92
TANK PRESSURE CONTROL VALVE		DIAGNOSTIC INDEX	F2- 95
(TPCV)	F2-31	QUICK DIAGNOSIS CHART	F2- 96
CHARCOAL CANISTER	F2-31	SYMPTOM TROUBLESHOOTING	F2- 98
CANISTER DRAIN CUT VALVE		DIAGNOSTIC INSPECTION	F2-117
(CDCV)	F2-32	SYSTEM INSPECTION	F2-119
PCV VALVE	F2-32		
PURGE SOLENOID VALVE	F2-32		
EGR VALVE	F2-32		
EGR SOLENOID VALVE	F2-33		
EGR BOOST SENSOR SOLENOID			
VALVE	F2-33		

ENGINE TUNE-UP

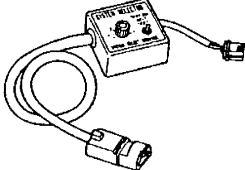
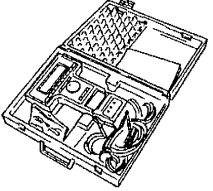
PREPARATION SST

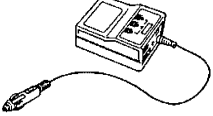
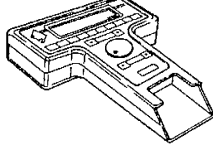
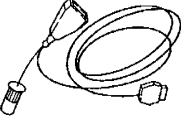
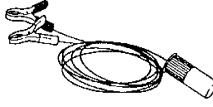
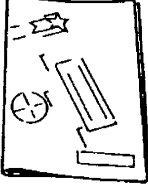
<p>49 B019 9A0</p> <p>System Selector</p> 	<p>For inspection of ignition timing and idle speed</p>	<p>49 T088 0A0</p> <p>NGS set</p> 	<p>For inspection of ignition timing and idle speed</p>
<p>49 T088 010B</p> <p>Program Card</p> 	<p>For inspection of ignition timing and idle speed</p>	<p>49 T088 002</p> <p>Vehicle Interface Module (Part of 49 T088 0A0)</p> 	<p>For inspection of ignition timing and idle speed</p>
<p>49 T088 001</p> <p>Control Unit (Part of 49 T088 0A0)</p> 	<p>For inspection of ignition timing and idle speed</p>	<p>49 T088 004</p> <p>NGS OBDII Adapter (Part of 49 T088 0A0)</p> 	<p>For inspection of ignition timing and idle speed</p>
<p>49 T088 006</p> <p>Battery Hookup Adapter (Part of 49 T088 0A0)</p> 	<p>For inspection of ignition timing and idle speed</p>	<p>49 T088 008A</p> <p>Instruction Manual</p> 	<p>For inspection of ignition timing and idle speed</p>

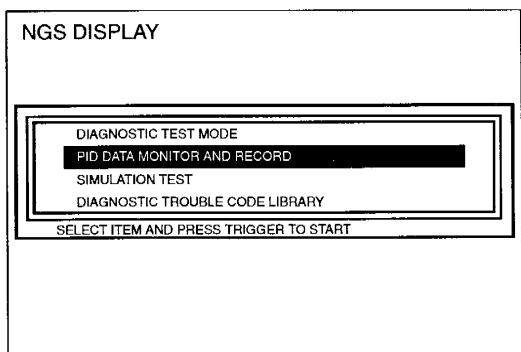

ADJUSTMENT

Preparation

1. Warm up the engine to normal operating temperature.
2. Shift the transaxle into Neutral (MTX) or P position (ATX).
3. Turn off all loads.
 - Headlight
 - Blower motor
 - Rear window defroster
 - Power steering
4. Wait until the cooling fan stops.
5. Connect the **SSTs** (NGS) to the data link connector-2 (Refer to page F2-38.) and select the PID/DATA MONITOR AND RECORD function.
6. Select the "RPM" on the NGS display.

Ignition Timing

1. Perform "Preparation". (Refer to above.)
2. Verify that the idle speed is within the specification.

Specification: 700—800 (750 ± 50) rpm

3. If not as specified, adjust the idle speed. (Refer to page F2-3.)

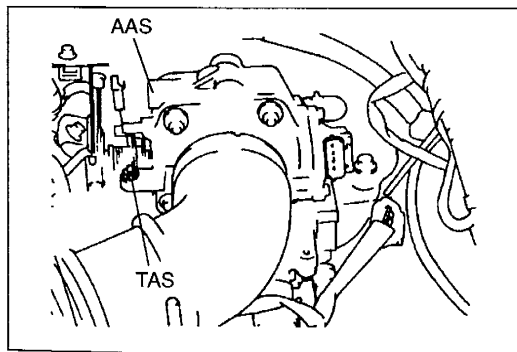
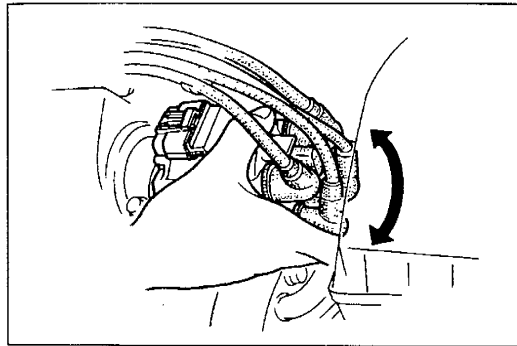
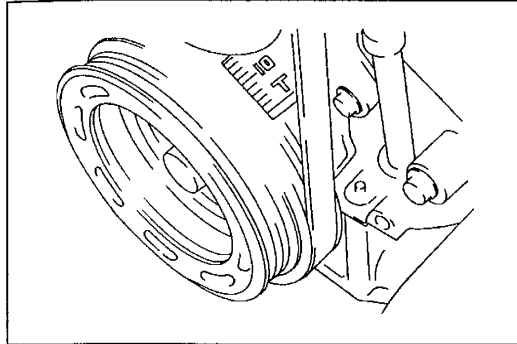
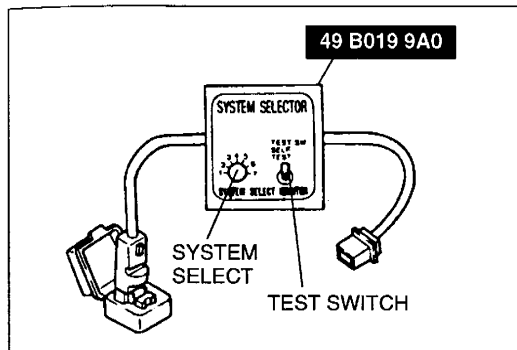

4. Connect the **SST** (System Selector) to the data link connector.
5. Set switch A to position 1.
6. Set the test switch to **SELF TEST**.
7. Connect a timing light to the high-tension lead of the No.1 cylinder.
8. Verify that the timing mark (white) is within the specification.

Specification: BTDC $-1-1^{\circ}$ ($0 \pm 1^{\circ}$)

9. If not as specified, loosen the distributor lock bolts and turn the distributor to make the adjustment.
10. Tighten the distributor lock bolts to the specified torque.

Tightening torque:

19—25 N·m { 1.9—2.6 kgf·m , 14—18 ft·lbf }

11. Disconnect the **SST** (System Selector).
12. Verify that the ignition timing is within the specification.

Specification: BTDC $6-18^{\circ}$

Idle Speed

1. Perform "Preparation". (Refer to page F2-2.)
2. Connect the **SST** (System Selector) to the data link connector.
3. Set switch A to position 1.
4. Set the test switch to **SELF TEST**.
5. Adjust the idle speed by turning the air adjusting screw.

Specification: 700—800 (750 ± 50) rpm

Caution

- The throttle adjusting screw is set at the factory and must not be adjusted. Any adjustment will negatively effect the engine performance.

6. Disconnect the **SST** (System Selector).

Idle Up Speed

1. Perform "Preparation". (Refer to page F2-2.)
2. Verify that the idle speed is within the specification.

Specification: 700—800 (750 ± 50) rpm

3. If not as specified, adjust the idle speed.
4. Check the idle speed with the following load conditions.

Specification

Load condition	Idle speed (rpm)	
	MTX	ATX
Fan switch ON at 2nd or higher	700—800	700—800
Headlight switch ON		
Rear window defroster switch ON		
P/S ON		
A/C ON		

Note

- Excludes temporary idle speed drop just after the electrical loads are turned on.
5. If not as specified with all load condition, inspect the idle air control valve. (Refer to page F2–8.)
If not as specified with each load condition, check related input switches, harnesses and connectors.

Idle Mixture

1. Perform "Preparation". (Refer to page F2–2.)
2. Verify that the idle speed and ignition timing are within the specification.
3. Insert an exhaust gas analyzer to the tailpipe.
4. Verify that the CO and HC concentrations are within the regulation.
5. If not, inspect the following.
 - On-board diagnostic system (Refer to page F2–54.)
 - Heated oxygen sensors (Refer to page F2–48.)
 - System inspection
 - Intake manifold vacuum (Refer to page F2–119.)
 - Fuel line pressure (Refer to page F2–120.)
 - Ignition timing control (Refer to page F2–127.)
6. If the systems are normal, replace the three way catalytic converter.

INTAKE-AIR SYSTEM

COMPONENT PARTS
Removal / Installation

Warning

- Fuel vapor is hazardous. It can very easily ignite, causing serious injury and damage. Always keep sparks and flames away from fuel.
- Fuel line spills and leaks are dangerous. Fuel can ignite and cause serious injuries or death and damage. Fuel can also irritate skin and eyes. To prevent this, always complete the "Fuel Line Safety Procedures" on page F2-11.

F2

1. Disconnect the negative battery cable.
2. Drain the engine coolant from the radiator. (Refer to section E.)
3. Remove in the order shown in the figure, referring to **Removal note**.
4. Install in the reverse order of removal, referring to **Installation note**.
5. Refill the radiator with the specified engine coolant. (Refer to section E.)

STEP 1

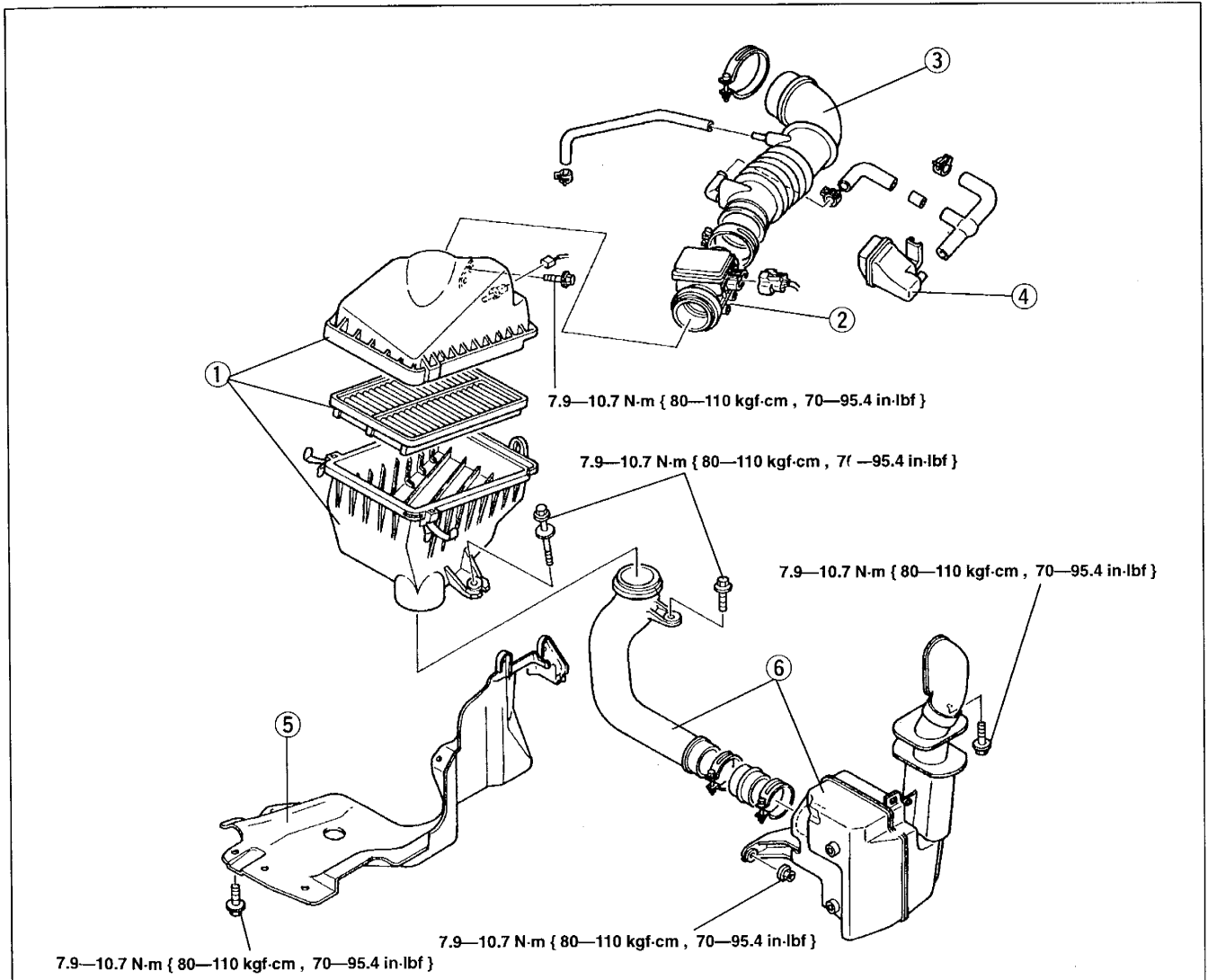

1. Air cleaner
2. Mass air flow sensor
3. Air intake hose
4. Resonance chamber

5. Splash shield
 6. Fresh-air duct
- Removal note page F2-6

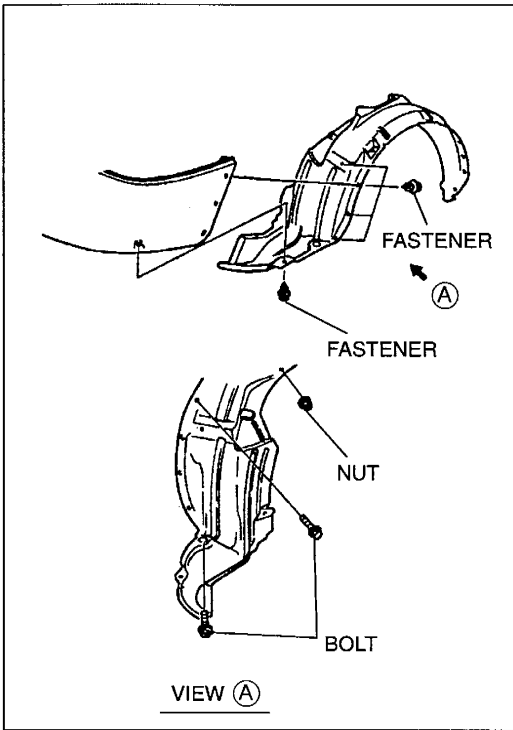

Removal note

Fresh-air duct

Before removing the fresh-air duct, remove the LH front mud guard mounting bolts, nut, and fasteners shown.

STEP 2

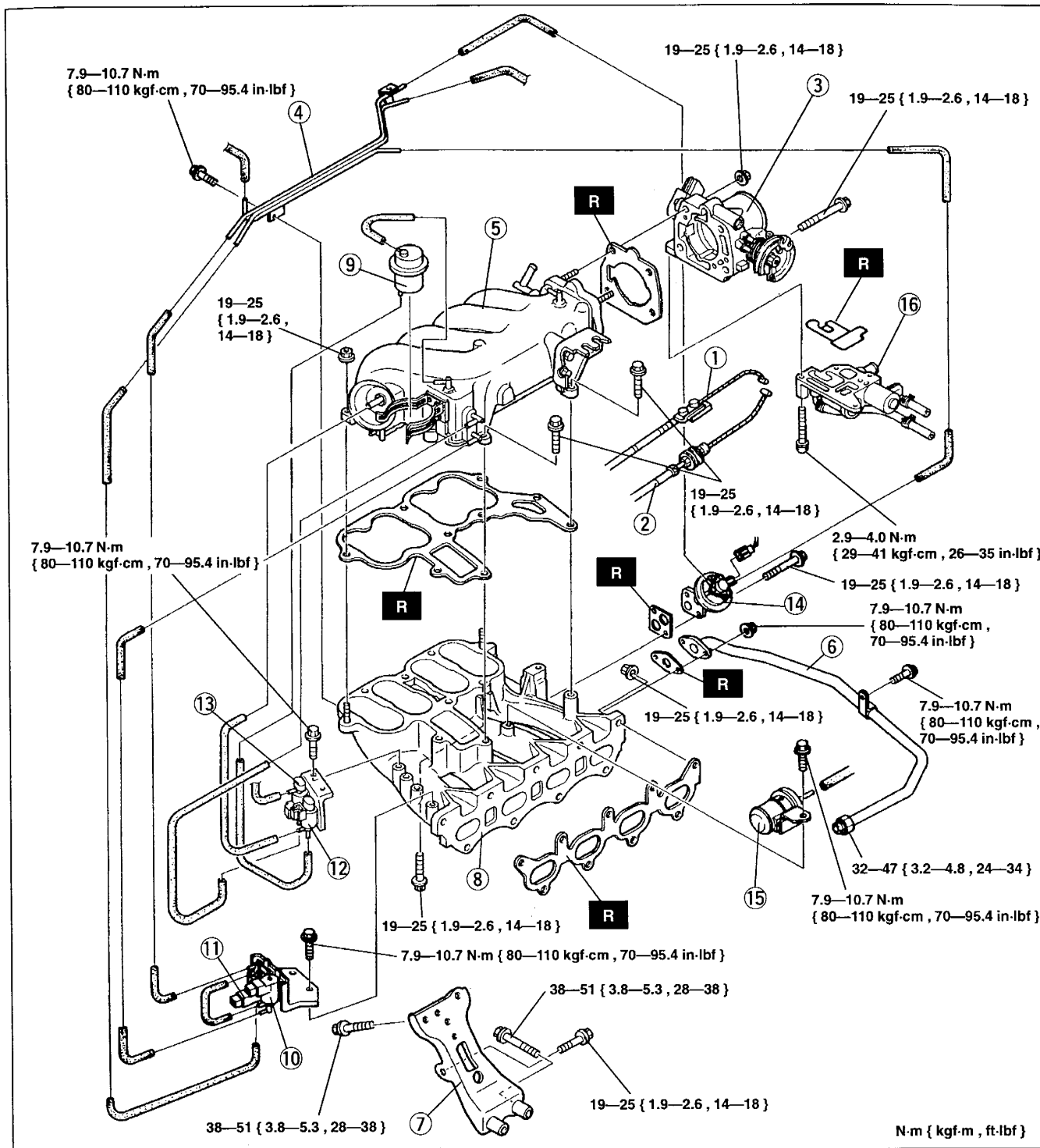

- | | |
|---|---|
| 1. Throttle cable (ATX)
Removal / Installation section K | 8. Intake manifold
Installation note page F2-8 |
| 2. Accelerator cable
Inspection / Adjustment page F2-10 | 9. Vacuum chamber |
| 3. Throttle body | 10. EGR solenoid valve (vacuum) |
| 4. Vacuum pipe | 11. EGR solenoid valve (vent) |
| 5. Dynamic chamber
Installation note page F2- 8 | 12. VICS solenoid valve |
| 6. EGR pipe | 13. PRC solenoid valve |
| 7. Intake manifold stay | 14. EGR valve |
| | 15. Air filter |
| | 16. BAC valve |

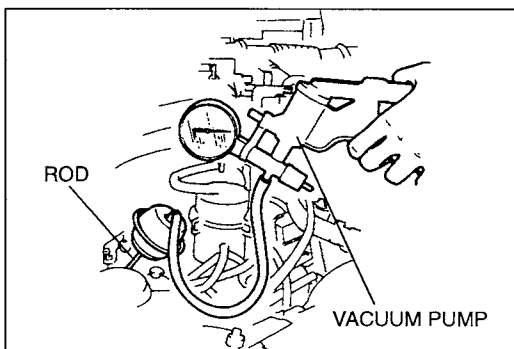
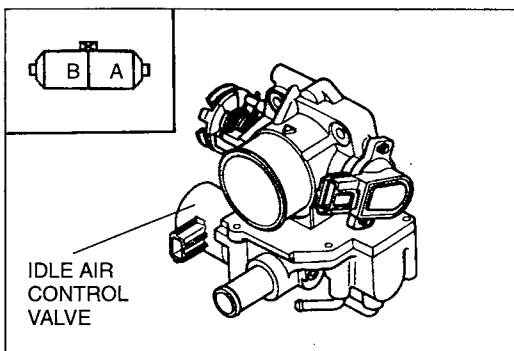
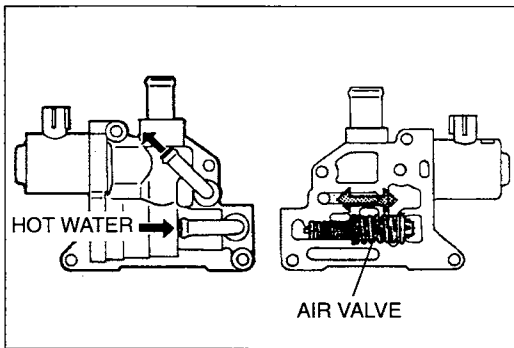
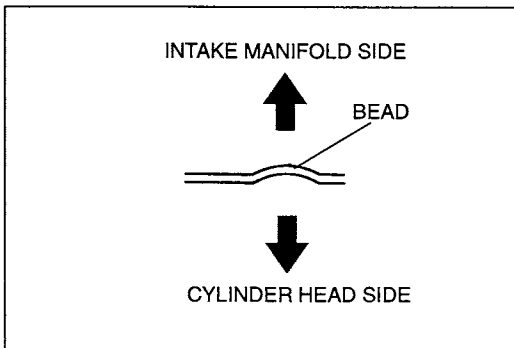
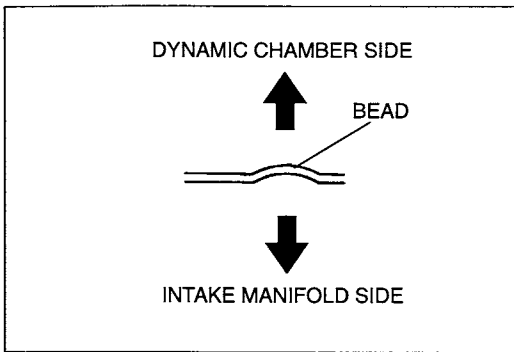

Installation note Dynamic chamber

Face the bead of the gasket as shown, and install the dynamic chamber.

Intake manifold

Face the bead of the gasket toward the intake manifold as shown, and install the intake manifold.

AIR VALVE

Inspection

1. Remove the BAC valve. (Refer to page F2-7.)
2. Circulate water in the BAC valve coolant passage to cool the air valve.
3. Circulate hot water in the BAC valve coolant passage and verify that the air valve operates.
4. If not operates, replace the BAC valve.

IDLE AIR CONTROL VALVE

Inspection

1. Verify that the ignition switch is OFF.
2. Disconnect the idle air control valve connector.
3. Measure the resistance of the idle air control valve by using an ohmmeter.

Specification: 10.7—12.3 Ω [20 °C { 68 °F }]

4. If not as specified, replace the BAC valve. (Refer to page F2-7.)

SHUTTER VALVE ACTUATOR

Inspection

1. Connect a vacuum pump to the shutter valve actuator as shown.
2. Apply vacuum of 4.0 kPa { 30 mmHg } and verify that the rod is pulled into the actuator.
3. Apply vacuum of 25.3 kPa { 190 mmHg } and verify that the actuator opens completely (rod fully pulled in).
4. Is not as specified, replace the shutter valve actuator together with the dynamic chamber. (Refer to page F2-7.)

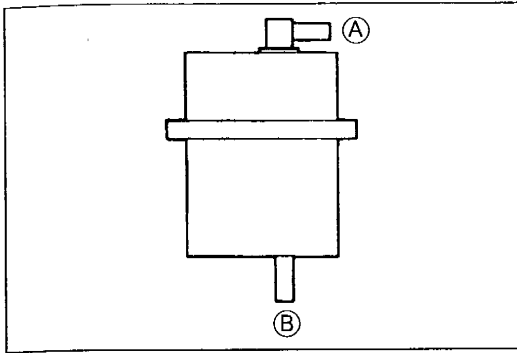

VACUUM CHAMBER

Inspection

1. Remove the vacuum chamber. (Refer to page F2-7.)
2. Visually inspect the outer surface for damage.
3. Blow air from port A and verify that there is no airflow.
4. Blow air from port B and verify that there is airflow.
5. If not as specified, replace the vacuum chamber.

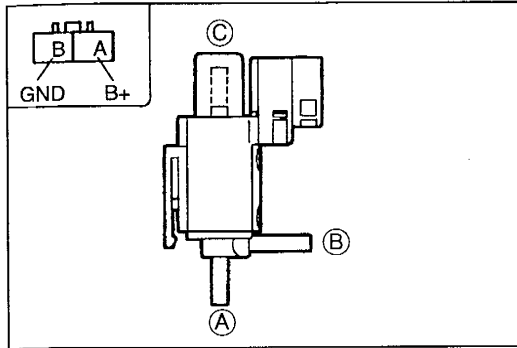

VICS SOLENOID VALVE

Inspection

1. Remove the VICS solenoid valve. (Refer to page F2-7.)
2. Check for air flow between ports of the solenoid valve.

○—○: Continuity ○—○: Air flow B+: Battery positive voltage

Step	Terminal		Port		
	A	B	A	B	C
1	○	○		○—○	
2	B+	Ground	○—○		

3. If not as specified, replace the VICS solenoid valve.

F2

ACCELERATOR PEDAL

Removal / Installation

1. Remove in the order shown in the figure.
2. Install in the reverse order of removal.

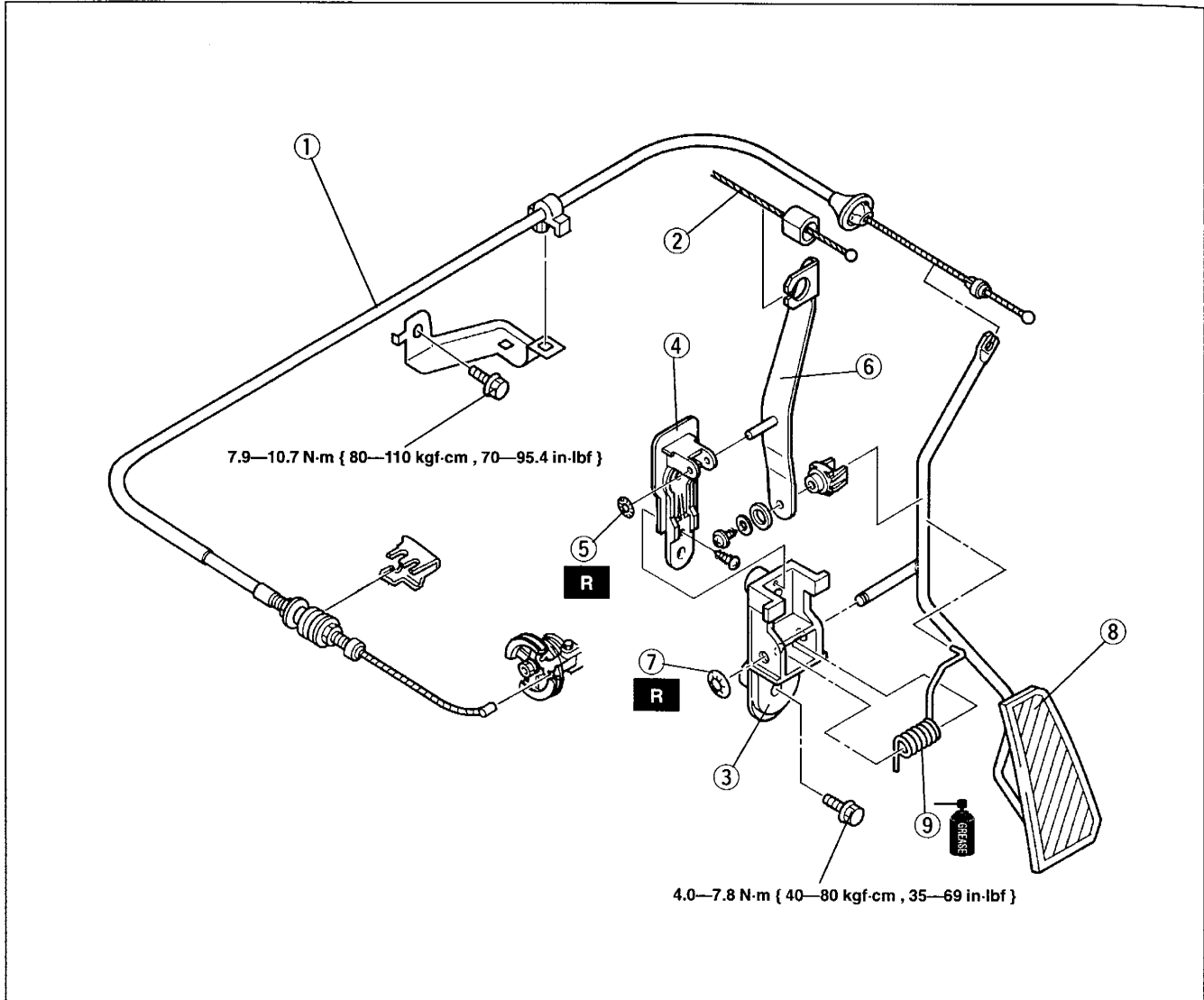

- | | |
|---|------------------------------------|
| 1. Accelerator cable
Inspection / Adjustment below | 5. Snap ring (with cruise control) |
| 2. Actuator cable (with cruise control) | 6. Bracket (with cruise control) |
| 3. Retainer | 7. Snap ring |
| 4. Retainer (with cruise control) | 8. Accelerator pedal |
| | 9. Return spring |

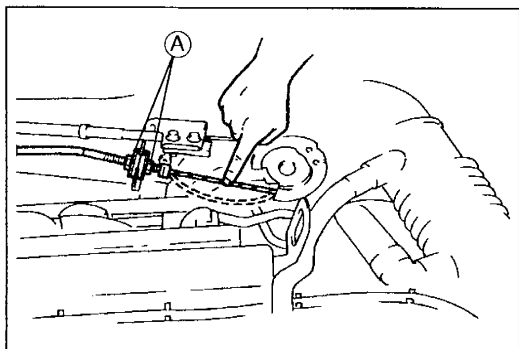

ACCELERATOR CABLE Inspection / Adjustment

1. Verify that the throttle valve is at the closed throttle position.
2. Measure the free play of the accelerator cable.

Free play: 1—3 mm { 0.04—0.11 in }

3. If not as specified, adjust by turning locknut (A).

FUEL SYSTEM

PREPARATION

SST

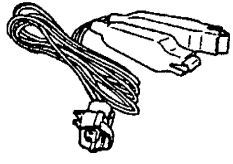
<p>49 L018 901</p> <p>Injector checker</p>		<p>For inspection of fuel injector</p>
--	---	--

PRECAUTION

Fuel Pressure Release and Servicing Fuel System

Warning

- Fuel vapor is hazardous. It can very easily ignite, causing serious injury and damage. Always keep sparks and flames away from fuel.

Fuel in the fuel system is under high pressure when the engine is not running.

Warning

- Fuel line spills and leaks are dangerous. Fuel can ignite and cause serious injuries or death and damage. Fuel can also irritate skin and eyes. To prevent this, always complete the following "Fuel Line Safety Procedures".

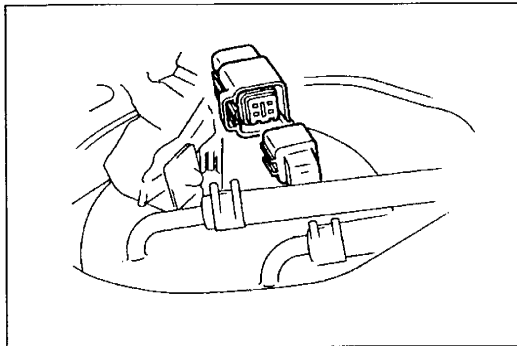

Fuel Line Safety Procedures

A. Release the fuel pressure before disconnecting a fuel line.

1. Remove the rear seat cushion. (Refer to section S.)
2. Disconnect the fuel pump connector.
3. Start the engine.
4. After the engine stalls, turn the ignition switch to OFF.
5. Connect the fuel pump connector and install the rear seat cushion.

B. Avoid leakage

1. When disconnecting a fuel line hose, wrap a rag around it to protect against fuel leakage.
2. Plug the hose after removal.

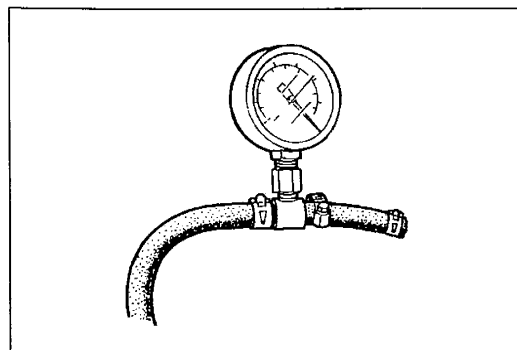

C. Install hose clamps to secure the fuel pressure gauge.

COMPONENT PARTS

Removal / Installation Fuel tank

Warning

- Fuel vapor is hazardous. It can very easily ignite, causing serious injury and damage. Always keep sparks and flames away from fuel.
- Fuel line spills and leaks are dangerous. Fuel can ignite and cause serious injuries or death and damage. Fuel can also irritate skin and eyes. To prevent this, always complete the "Fuel Line Safety Procedures" on page F2-11.
- Repairing a fuel tank that has not been properly steam cleaned can be dangerous. Explosion or fire may cause death or serious injury. Always properly steam clean a fuel tank before repairing it.

1. Disconnect the negative battery cable.
2. Remove the drain plug and drain the fuel from the fuel tank.
3. Remove the rear seat cushion. (Refer to section S.)
4. Remove in the order shown in the figure.
5. Install in the reverse order of removal, referring to **Installation note**.
6. After installation, verify that the fuel tank is securely fixed.

STEP 1

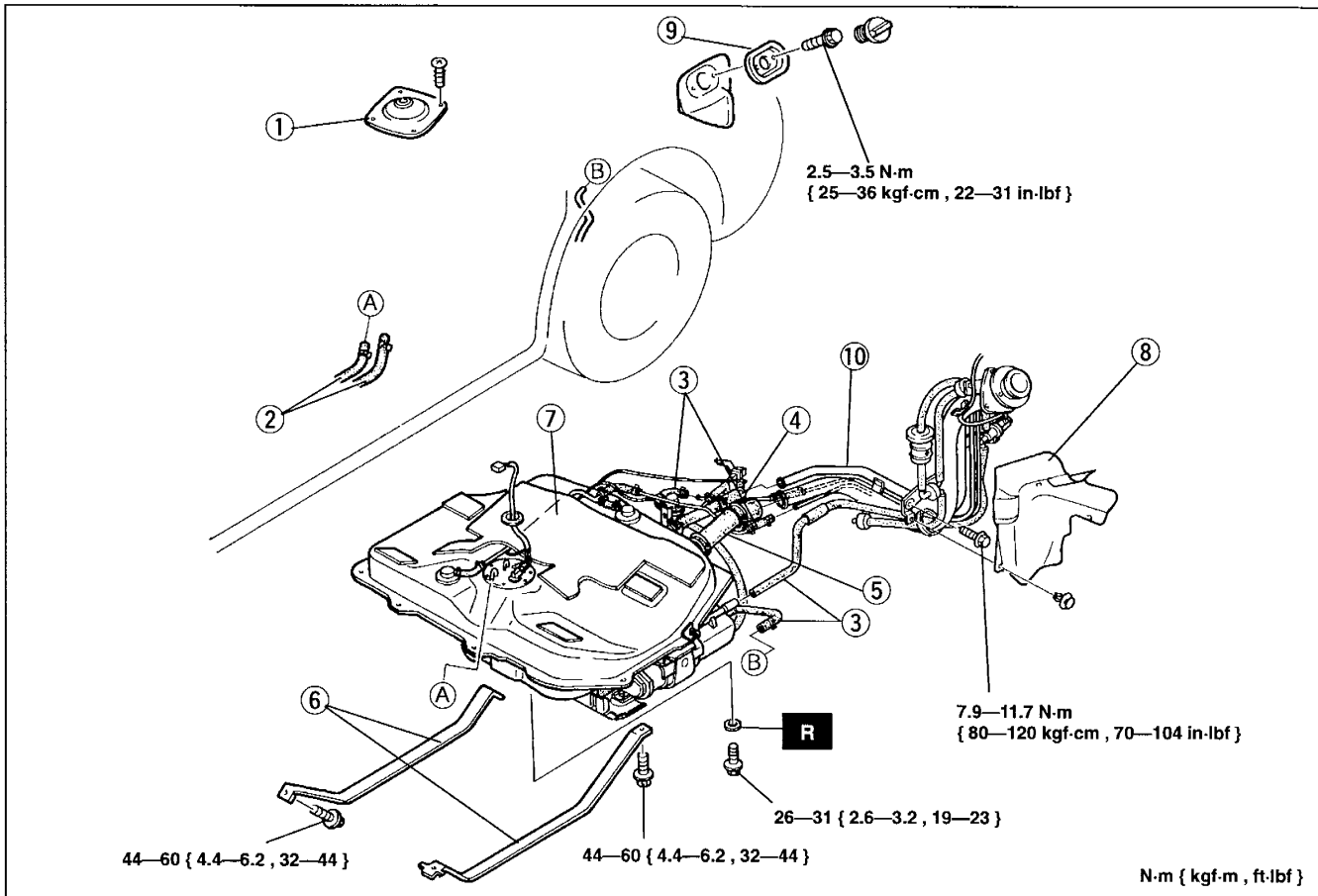

- | | |
|------------------------------------|------------------------------------|
| 1. Fuel pump cover | 5. Joint hose |
| 2. Fuel hose | Installation note page F2-13 |
| Installation note page F2-13 | 6. Fuel tank strap |
| 3. Evaporative hose | 7. Fuel tank |
| Installation note page F2-13 | 8. Protector |
| 4. Breather hose | 9. Dust cover |
| Installation note page F2-13 | 10. Fuel filler pipe |

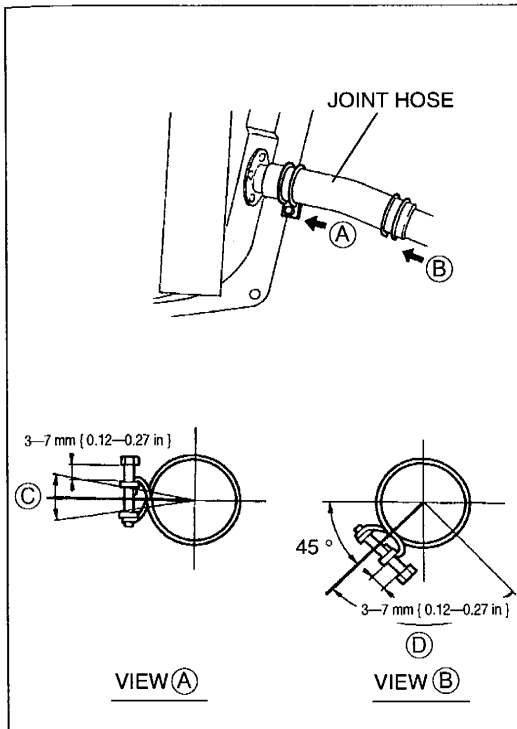

Installation note

Fuel hoses, evaporative hoses, breather hose

- Push the ends of the fuel hoses, evaporative hoses, and breather hose onto the respective fittings.

Specification: 25—30 mm { 0.99—1.18 in }

- Be sure the hoses are not bent or twisted.

Joint hose

- Push the ends of the joint hose onto the fitting.

Specification: 35—40 mm { 1.38—1.57 in }

- Install the clamps on the joint hose as shown.
- Position the tabs of each clamp within the allowable range.

Allowance

- Ⓒ: 10° to both directions
- Ⓓ: 90° to right

- Be sure the hose is not bent or twisted.

STEP 2

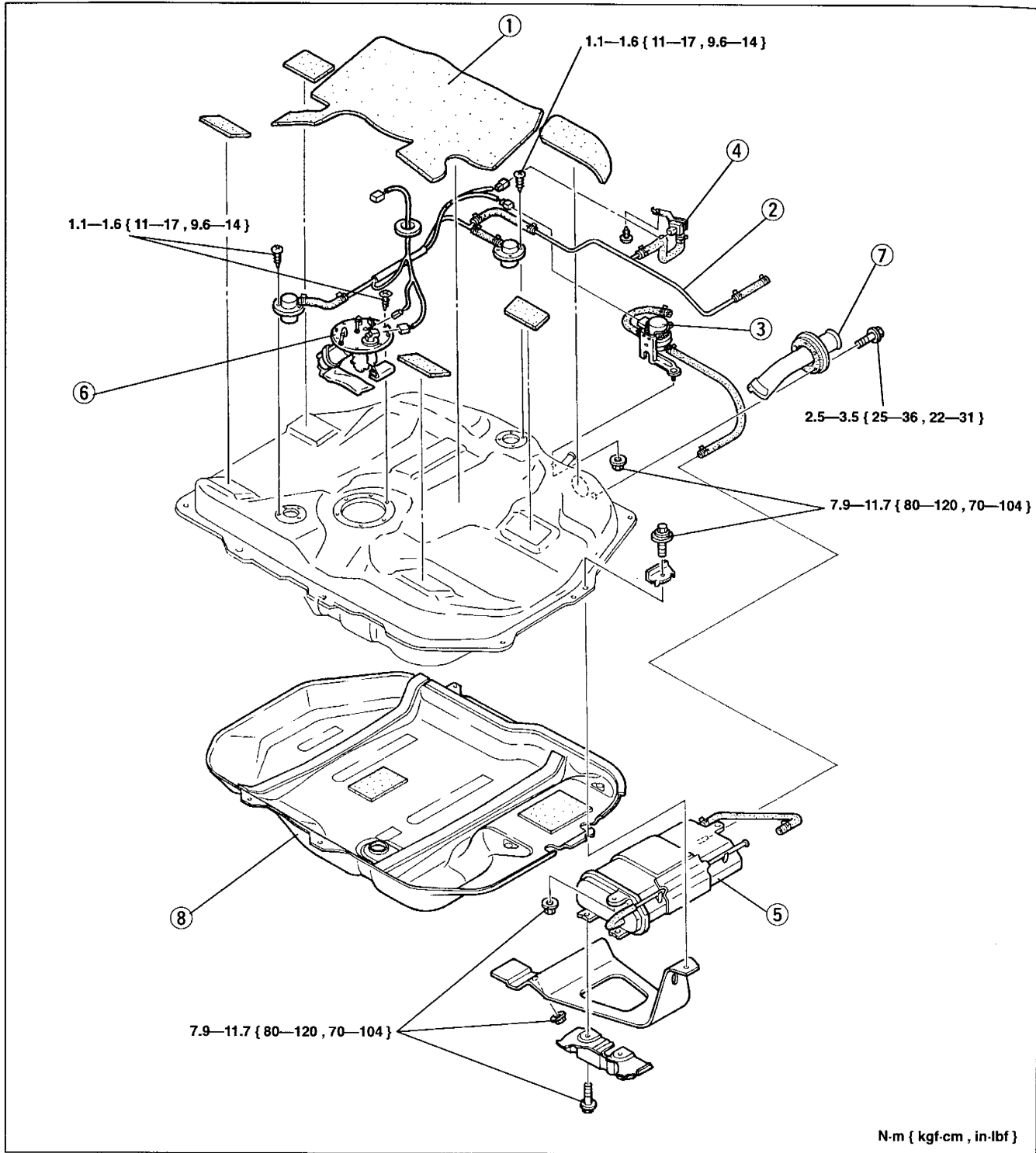

- | | |
|---------------------------------------|-------------------------------|
| 1. Pad | 5. Charcoal canister |
| Installation note page F2-15 | 6. Fuel pump |
| 2. Fuel pipe, rollover valve | 7. Inlet pipe |
| Installation note page F2-15 | Removal note page F2-15 |
| 3. Tank pressure control valve (TPCV) | 8. Insulator |
| 4. Fuel tank pressure sensor | |

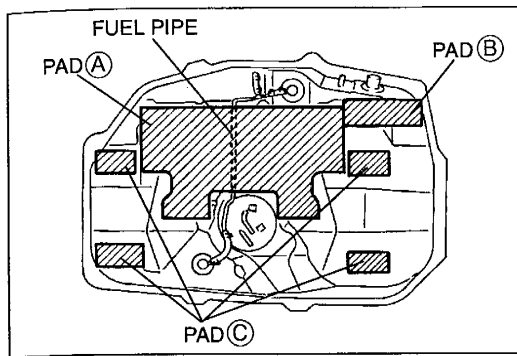
**Removal note****Inlet pipe**

- Remove the inlet pipe only when replacing the non-return valve.

Installation note**Fuel pipe, pad**

- Stick pad (A) onto the fuel tank, over the harness (California only) and the fuel pipe as shown.
- Stick pads (B) and (C) onto the fuel tank as shown. (Upper surface of the fuel tank is projected for installation of pads (C).)
- Be sure the hoses are not bent or twisted.

Fuel pump

Warning

- Fuel line spills and leaks are dangerous. Fuel can ignite and cause serious injuries or death and damage. Fuel can also irritate skin and eyes. To prevent this, always complete the “Fuel Line Safety Procedures” on page F2-11.

1. Disconnect the negative battery cable.
2. Remove the rear seat cushion. (Refer to section S.)
3. Remove in the order shown in the figure.
4. Install in the reverse order of removal, referring to **Installation note**.

STEP 1

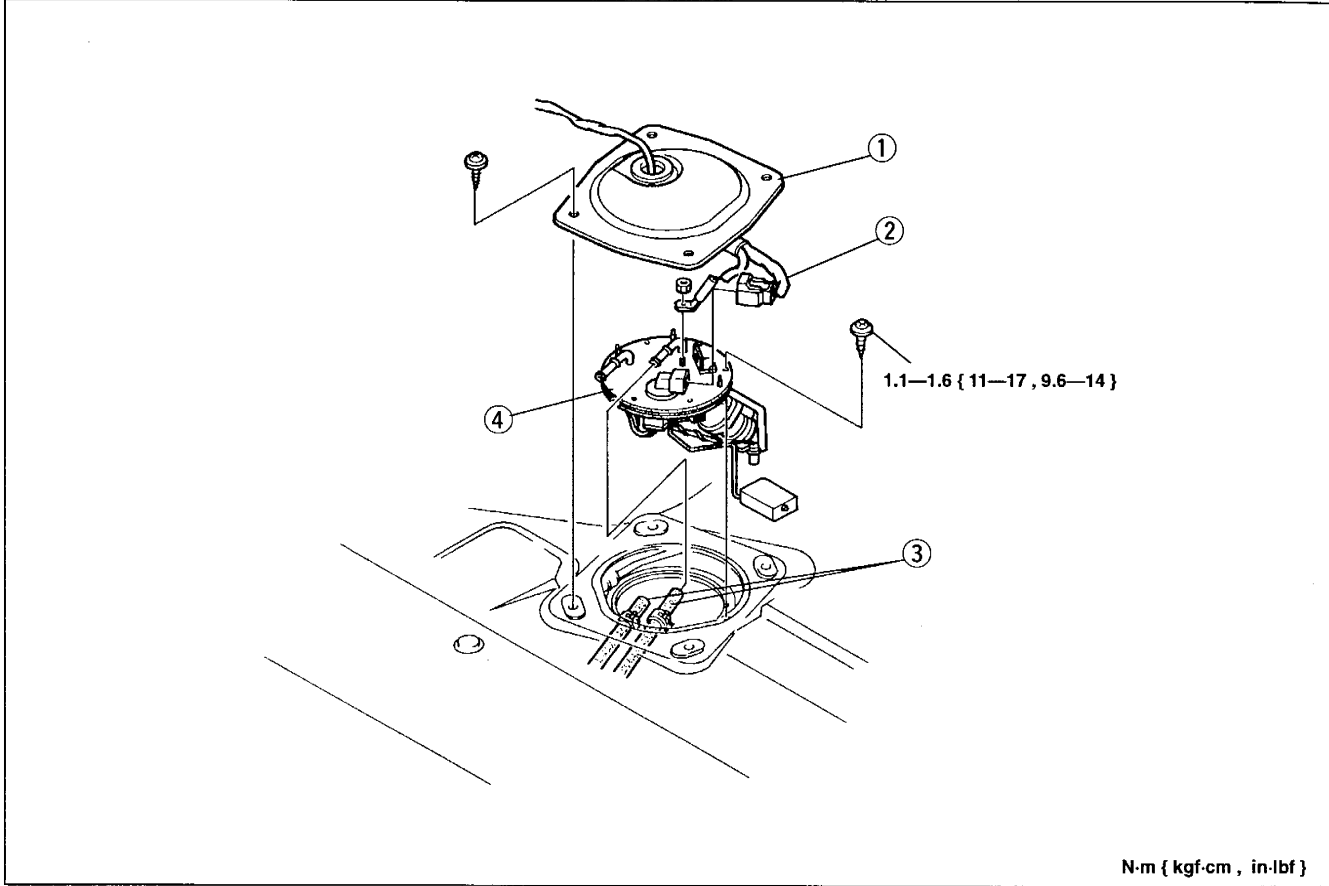

1. Fuel pump cover
2. Fuel pump connector
3. Fuel hoses

4. Fuel pump

Installation note below

Installation note

Fuel hoses

- Push the ends of the fuel hoses onto the respective fittings.

Specification: 25—30 mm { 0.99—1.18 in }

- Be sure the hoses are not bent or twisted.

STEP 2

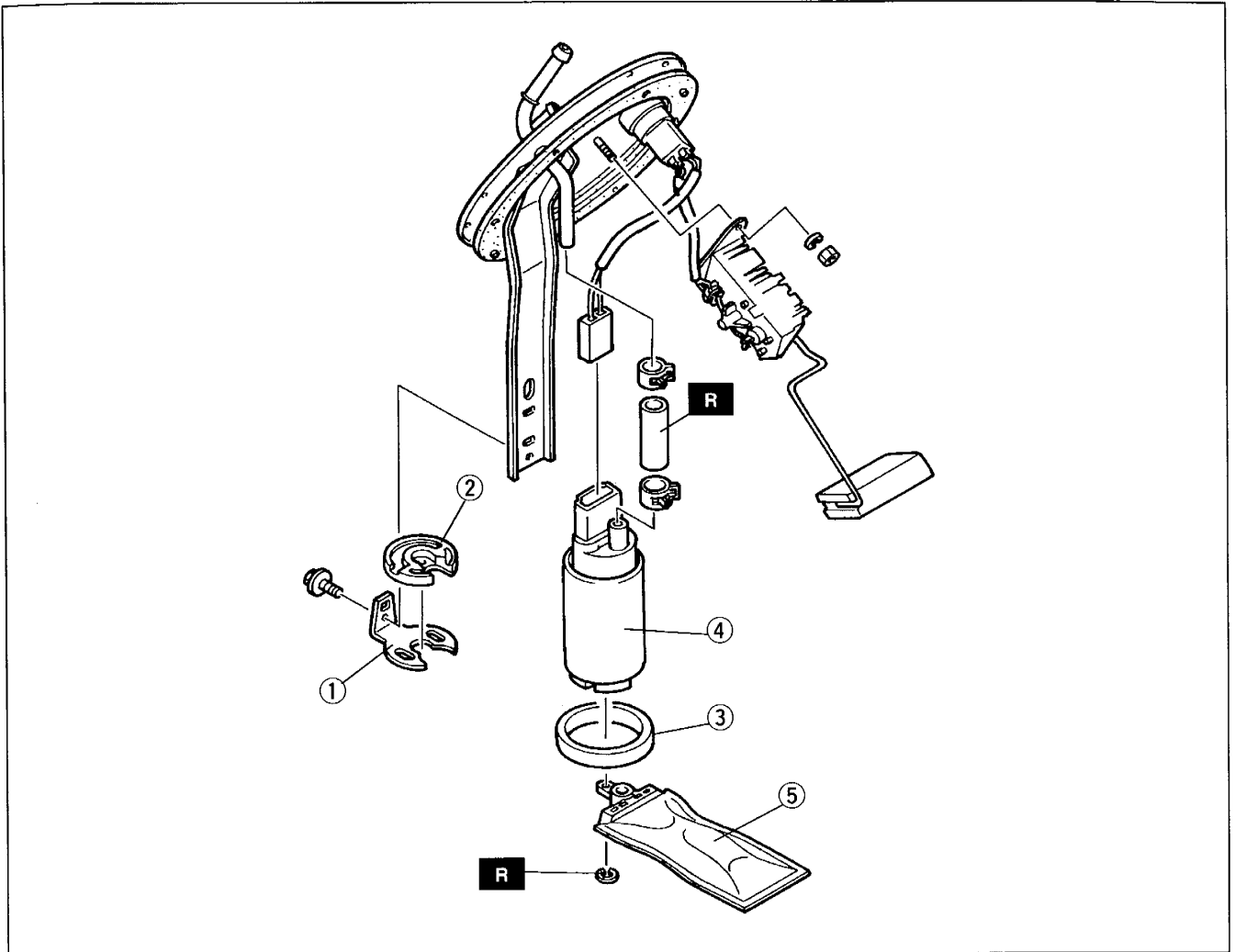

- 1. Bracket
- 2. Rubber mount
- 3. Band

- 4. Fuel pump
- 5. Fuel filter (low pressure side)

Fuel injector

Warning

- Fuel line spills and leaks are dangerous. Fuel can ignite and cause serious injuries or death and damage. Fuel can also irritate skin and eyes. To prevent this, always complete the "Fuel Line Safety Procedures" on page F2-11.

- Disconnect the negative battery cable.
- Remove in the order shown in the figure.
- Install in the reverse order of removal, referring to **Installation note**.
- Verify that the fuel injectors are properly installed by referring to **Steps after installation**.

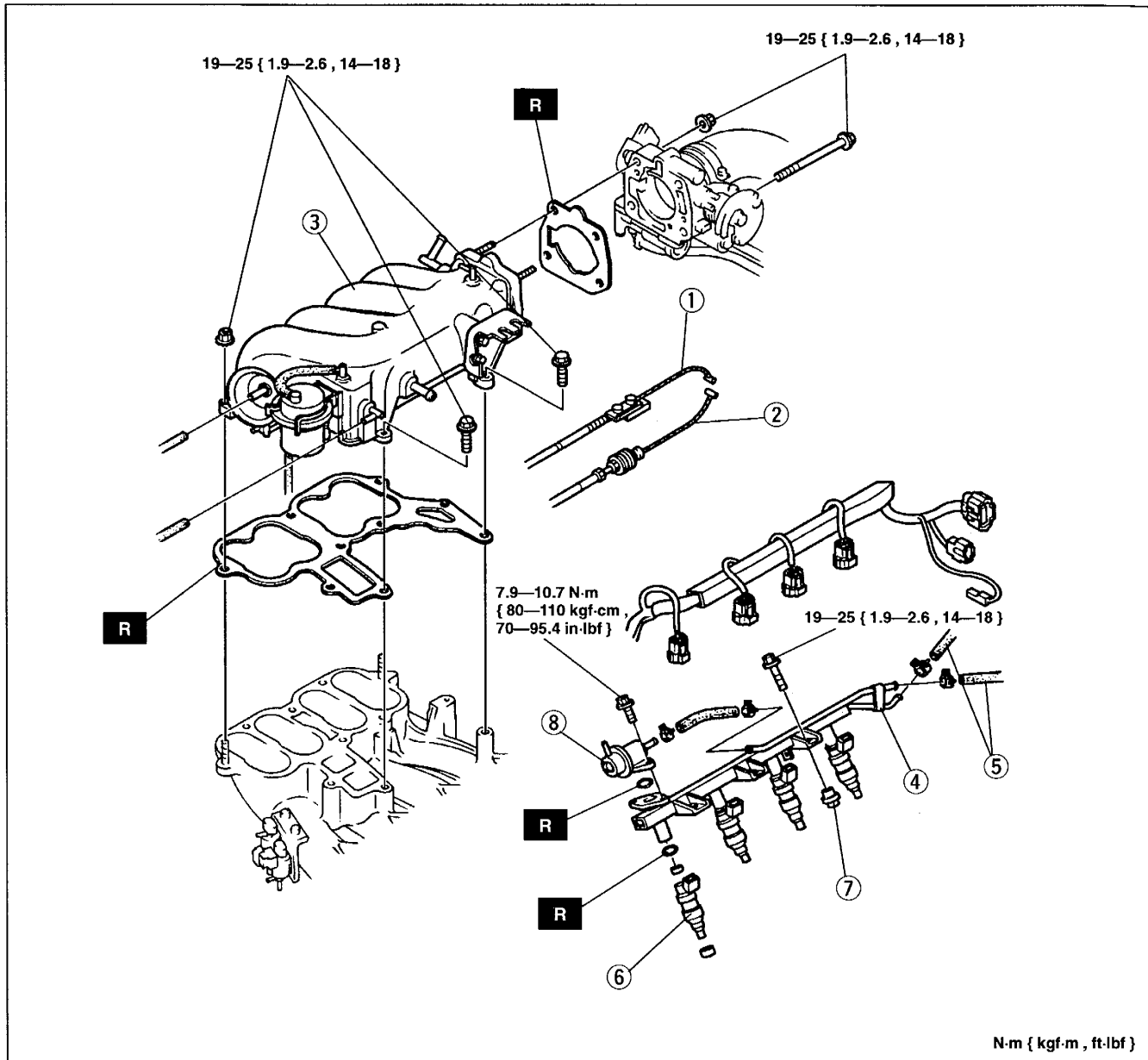

- Throttle cable
Removal / Installation section K
- Accelerator cable
Inspection / Adjustment page F2-10
- Dynamic chamber
- Fuel distributor

- Fuel hoses
Installation note page F2-19
- Fuel injector
Installation note page F2-19
- Insulator
- Pressure regulator
Installation note page F2-19

Installation note**Fuel injector, pressure regulator**

- Apply a small amount of clean engine oil to the new O-rings, and install them.

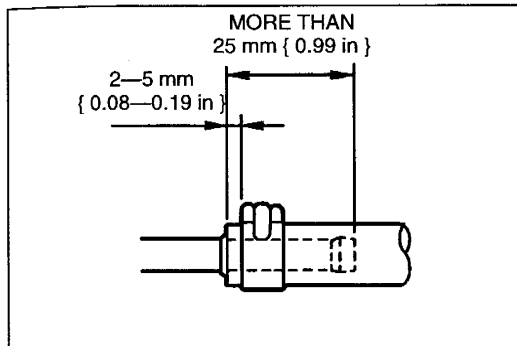
**Fuel hoses**

- Push the ends of the fuel hoses onto the respective fittings.

Specification: More than 25 mm { 0.99 in }

- Install the clips on the fuel hoses.

Specification:

2-5 mm { 0.08-0.19 in } from the end of hose

Steps after installation

1. Connect data link connector terminals F/P and GND with a jumper wire.
2. Turn the ignition switch to ON and check for fuel leaks from the fuel distributor assembly.
3. Turn off the ignition switch and disconnect the jumper wire.
4. If leaks are found, reinstall the fuel injector.

Fuel filter (high pressure side), PRC solenoid valve, fuel pump relay

Warning

- Fuel line spills and leaks are dangerous. Fuel can ignite and cause serious injuries or death and damage. Fuel can also irritate skin and eyes. To prevent this, always complete the "Fuel Line Safety Procedures" on page F2-11.

Note

- The fuel filter must be replaced at the intervals outlined in the maintenance schedule.

- Disconnect the negative battery cable.
- Remove in the order shown in the figure, referring to **Removal note**.
- Install in the reverse order of removal, referring to **Installation note**.

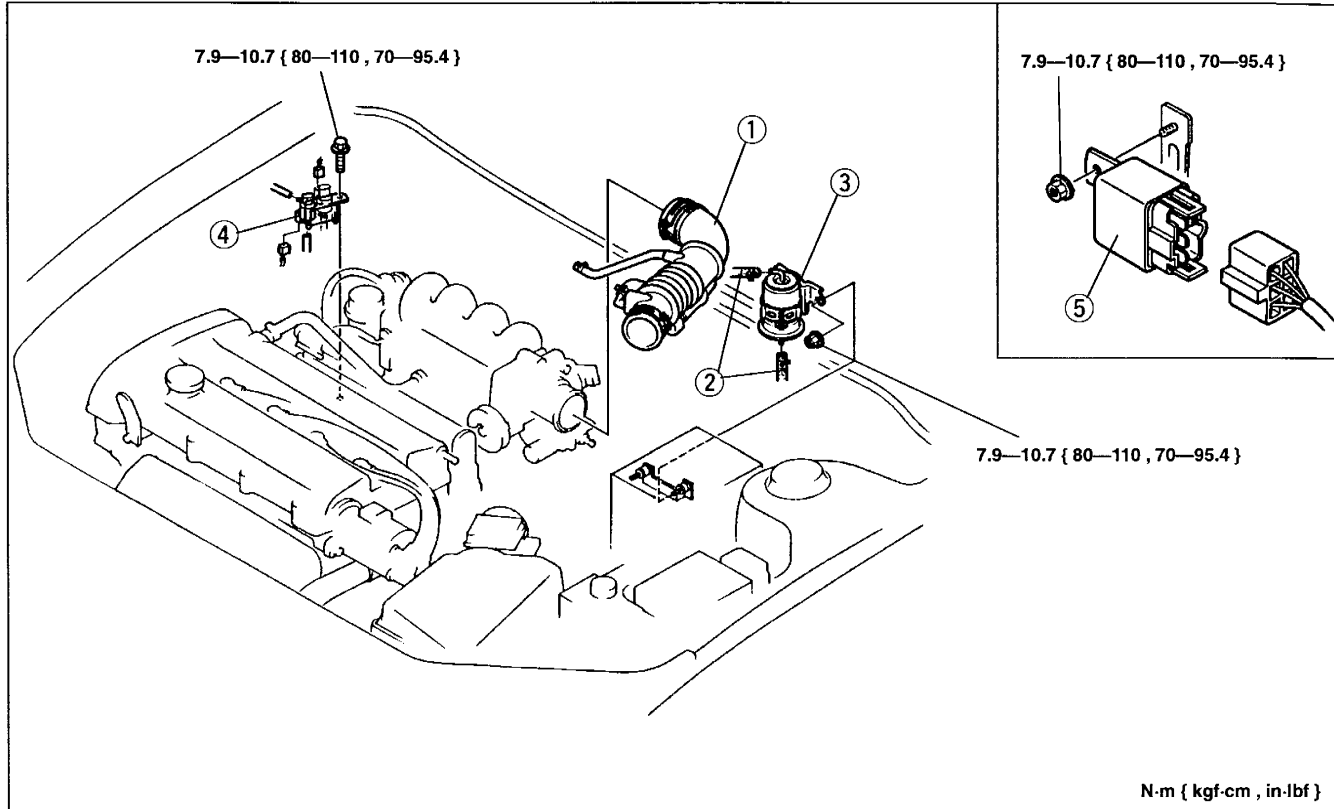

1. Air intake hose

2. Fuel hoses

Installation note below

3. Fuel filter (high pressure side)

4. PRC solenoid valve (ATX)

5. Fuel pump relay

Removal note below

Removal note

Fuel pump relay

- Before removing the fuel pump relay, remove the rear console, front console and side wall. (Refer to section S.)

Installation note

Fuel hoses

- Push the ends of the fuel hoses onto the fittings until it stops.
- Install the clips on the fuel hoses.

Specification:

2—5 mm { 0.08—0.19 in } from the end of hose

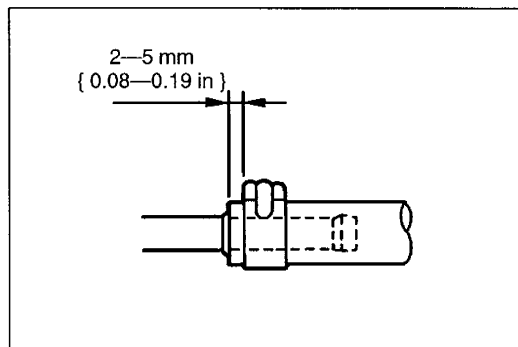

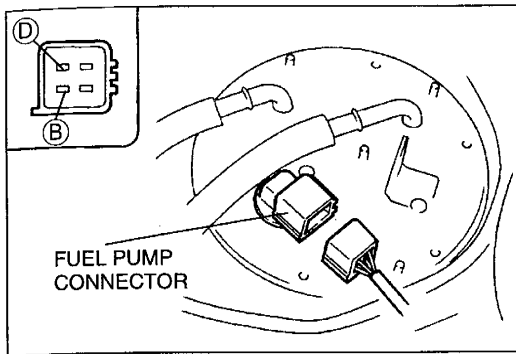

FUEL PUMP

Inspection

Fuel pump continuity

1. Remove the rear seat cushion. (Refer to section S.)
2. Remove the fuel pump cover.
3. Disconnect the fuel pump connector.
4. Check for continuity between fuel pump connector terminals B and D.
5. If there is no continuity, replace the fuel pump. (Refer to page F2-16.)

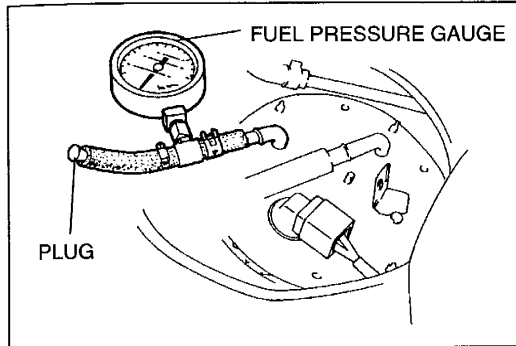

Fuel pump maximum pressure

Warning

- Fuel line spills and leaks are dangerous. Fuel can ignite and cause serious injuries or death and damage. Fuel can also irritate skin and eyes. To prevent this, always complete the "Fuel Line Safety Procedures" on page F2-11.

1. Disconnect the negative battery cable.
2. Connect a fuel pressure gauge to the fuel pump and plug the outlet of the gauge as shown.
3. Connect the negative battery cable.
4. Connect data link connector terminals F/P and GND by using a jumper wire.
5. Turn the ignition switch to ON. Measure the fuel pump pressure.

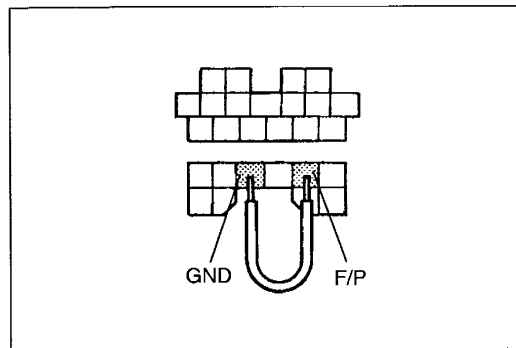

Pressure:

500—630 kPa { 5.0—6.5 kgf/cm² , 72—92 psi }

6. Turn off the ignition switch and disconnect the jumper wire.
7. If not as specified, replace the fuel pump. (Refer to page F2-16.)

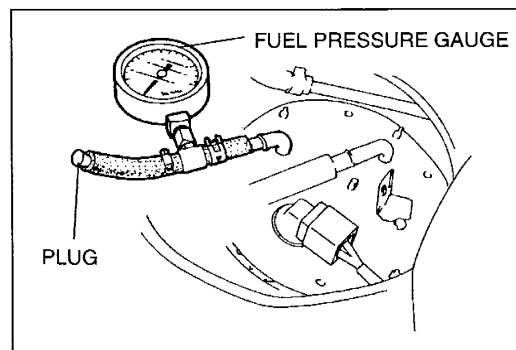

Fuel pump fuel hold pressure

Warning

- Fuel line spills and leaks are dangerous. Fuel can ignite and cause serious injuries or death and damage. Fuel can also irritate skin and eyes. To prevent this, always complete the "Fuel Line Safety Procedures" on page F2-11.

1. Disconnect the negative battery cable.
2. Connect a fuel pressure gauge to the fuel pump and plug the outlet of the gauge as shown.
3. Connect the negative battery cable.

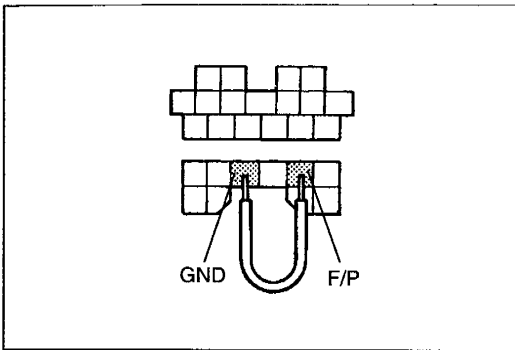

4. Connect data link connector terminals F/P and GND by using a jumper wire.
5. Turn the ignition switch to ON for approx. 10 sec. to operate the fuel pump.
6. Turn off the ignition switch. Wait for 5 min., and observe the fuel pressure.

Pressure: More than 150 kPa { 1.5 kgf/cm² , 21 psi }

7. Disconnect the jumper wire.
8. If not as specified, replace the fuel pump.
(Refer to page F2-16.)

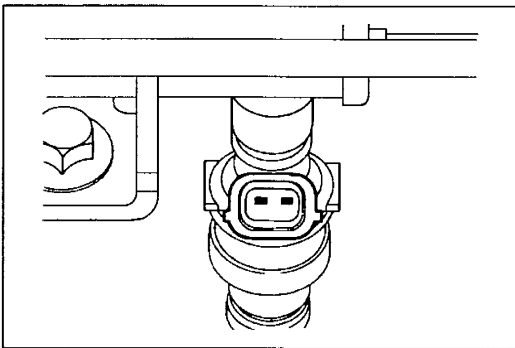

FUEL INJECTOR

Inspection

Resistance

1. Disconnect the fuel injector connectors.
2. Measure the resistance of the fuel injectors.

Resistance: Approx. 13.8 Ω [20 °C { 68 °F }]

3. If not as specified, replace the fuel injector.
(Refer to page F2-18.)

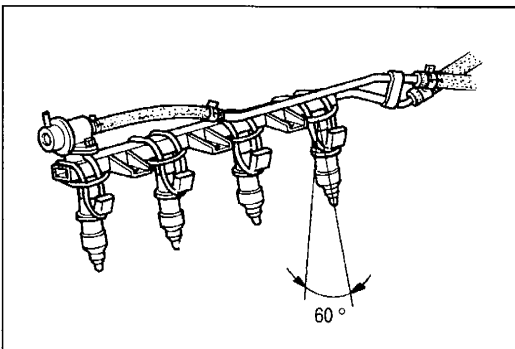

Fuel leakage test

1. Remove the fuel injectors together with the fuel distributor. (Refer to page F2-18.)
2. Fasten the fuel injectors firmly to the fuel distributor with wire and connect the fuel hoses.
3. Tilt the fuel injectors approx. 60 degrees from upright position as shown.
4. Connect data link connector terminals F/P and GND by using a jumper wire.
5. Turn the ignition switch to ON and check for fuel leaks from the fuel injectors.

Fuel leakage: Less than 1 drop/2 minutes

6. Turn off the ignition switch and disconnect the jumper wire.
7. If not as specified, remove the leaking fuel injector and reinstall the fuel injector, referring to **Installation note**.
8. Recheck the fuel leakage. If not as specified, replace the fuel injector. (Refer to page F2-18.)

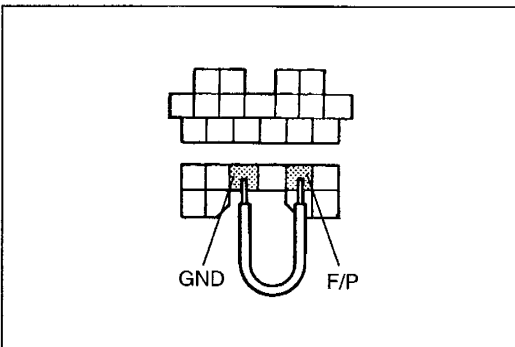

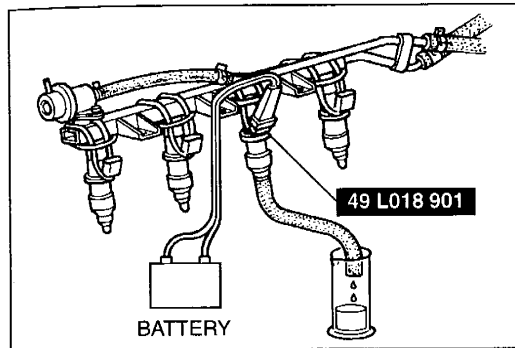
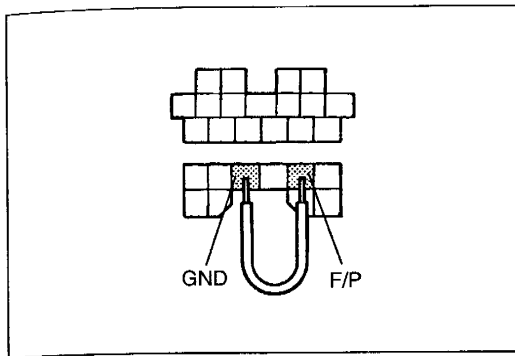

Volume test

1. Remove the fuel injectors together with the fuel distributor. (Refer to page F2-18.)
2. Fasten the fuel injectors firmly to the fuel distributor with wire and connect the fuel hoses.
3. Connect data link connector terminals F/P and GND by using a jumper wire.
4. Turn the ignition switch to ON.
5. Connect the **SST** as shown in the figure.
6. Measure the injection volume of each fuel injector by using a graduated container.

Injection volume:

59—76 ml { 59—76 cc , 2.0—2.5 fl oz }/15 sec.

7. Turn off the ignition switch and disconnect the jumper wire.
8. If not as specified, replace the fuel injector. (Refer to page F2-18.)

PRESSURE REGULATOR

Inspection

Warning

- **Fuel line spills and leaks are dangerous. Fuel can ignite and cause serious injuries or death and damage. Fuel can also irritate skin and eyes. To prevent this, always complete the “Fuel Line Safety Procedures” on page F2-11.**

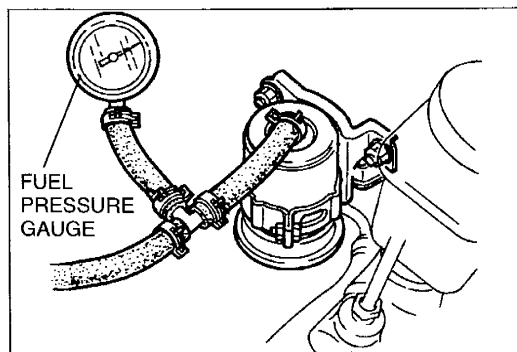

1. Disconnect the negative battery cable.
2. Remove the air intake hose. (Refer to page F2-5.)
3. Connect a fuel pressure gauge between the fuel filter (high pressure side) and the main fuel hose.
4. Install the air intake hose.
5. Connect the negative battery cable.
6. Start the engine and let it idle.
7. Carry out the intake manifold vacuum inspection. (Refer to page F2-119.)
8. Measure the fuel line pressure.

Pressure:

200—240 kPa { 2.0—2.4 kgf/cm² , 29—34 psi }

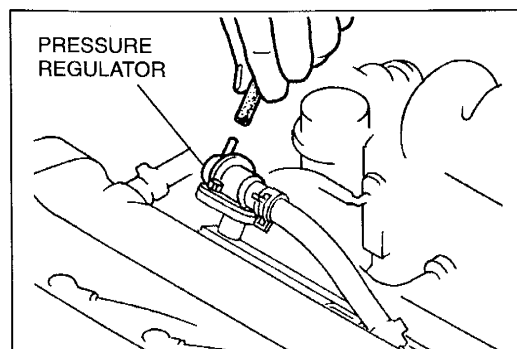

9. If not as specified, carry out the fuel line pressure inspection (Refer to page F2-121.) and inspect the PRC solenoid valve. (Refer to page F2-24.)
10. Disconnect the vacuum hose from the pressure regulator.
11. Measure the fuel line pressure.

Pressure:

280—310 kPa { 2.8—3.2 kgf/cm² , 40—45 psi }

12. If not as specified, replace the pressure regulator. (Refer to page F2-18.)

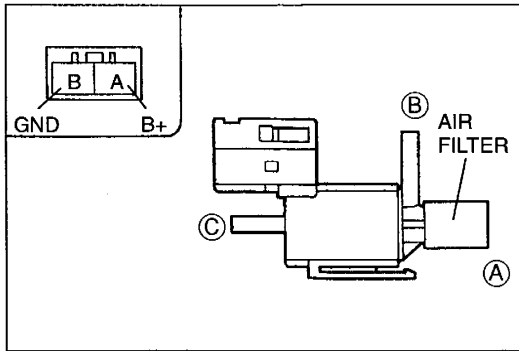

PRC SOLENOID VALVE

ATX

Inspection

1. Remove the PRC solenoid valve. (Refer to page F2-20.)
2. Check for air flow between ports of the solenoid valve.

○—○: Continuity ○—○ : Air flow B+: Battery positive voltage

Step	Terminal		Port		
	A	B	A	B	C
1	○—○	○—○		○—○	○—○
2	B+	Ground	○—○	○—○	

3. If not as specified, replace the PRC solenoid valve.

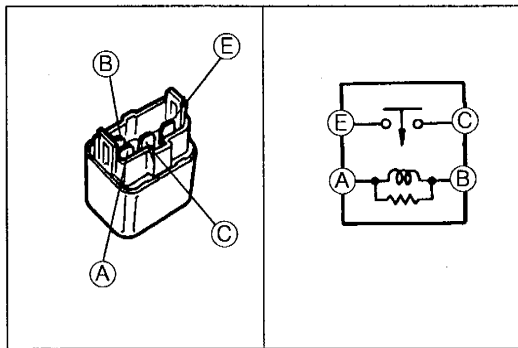

FUEL PUMP RELAY

Inspection

1. Remove the fuel pump relay. (Refer to page F2-20.)
2. Check for continuity between terminals of the relay by using an ohmmeter.

○—○: Continuity B+: Battery positive voltage

Step	Terminal	A	B	C	E
1		○—○	○—○		
2		B+	Ground	○—○	○—○

3. If not as specified, replace the fuel pump relay.

EXHAUST SYSTEM**COMPONENT PARTS****Inspection**

1. Start the engine and check for exhaust gas leakage from each exhaust system components.
2. If leakage is found, repair or replace as necessary.

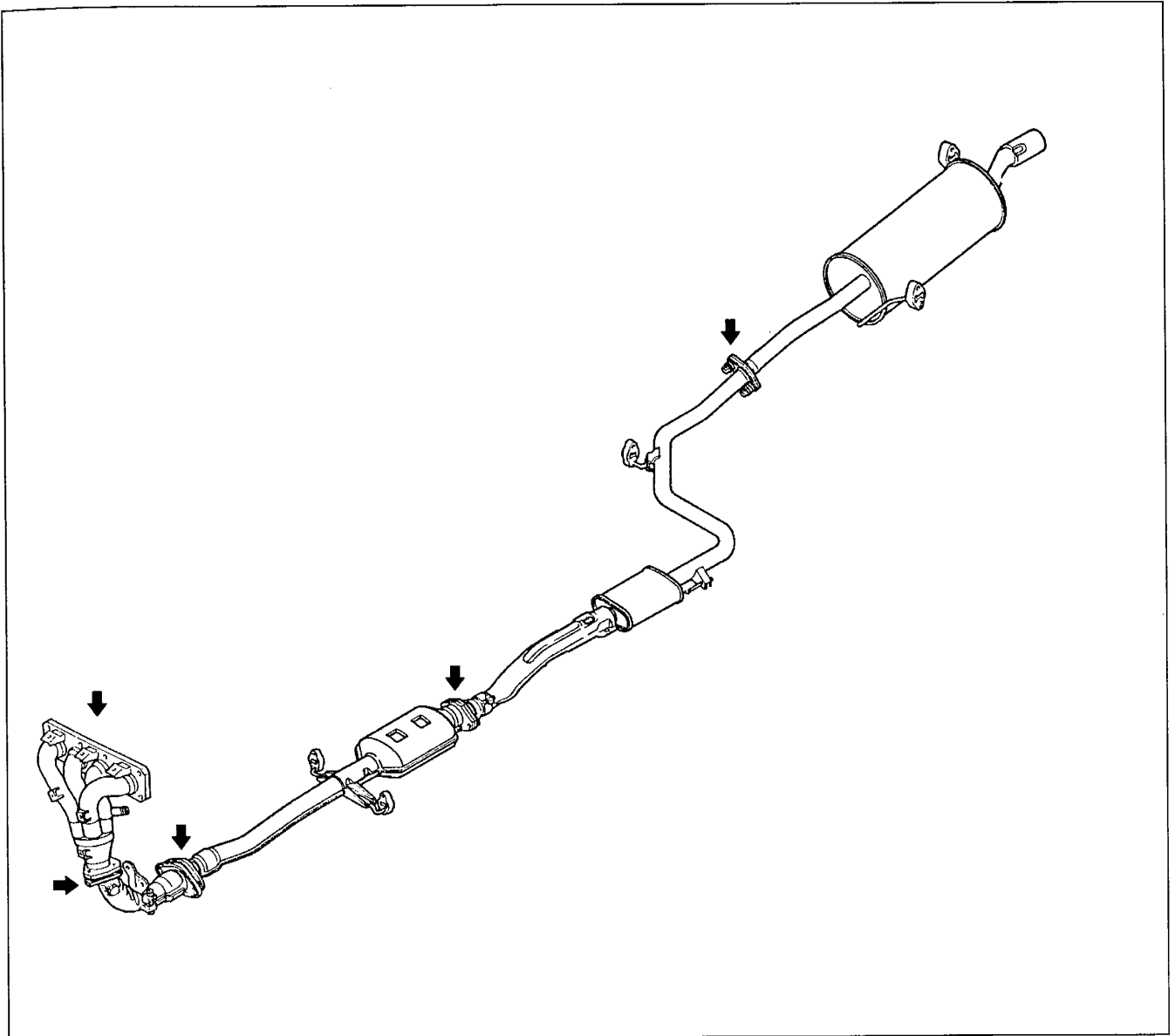

Removal / Installation

1. Disconnect the negative battery cable.
2. Remove the condenser fan. (Refer to section U.)
3. Remove in the order shown in the figure, referring to **Removal note**.
4. Install in the reverse order of removal, referring to **Installation note**.

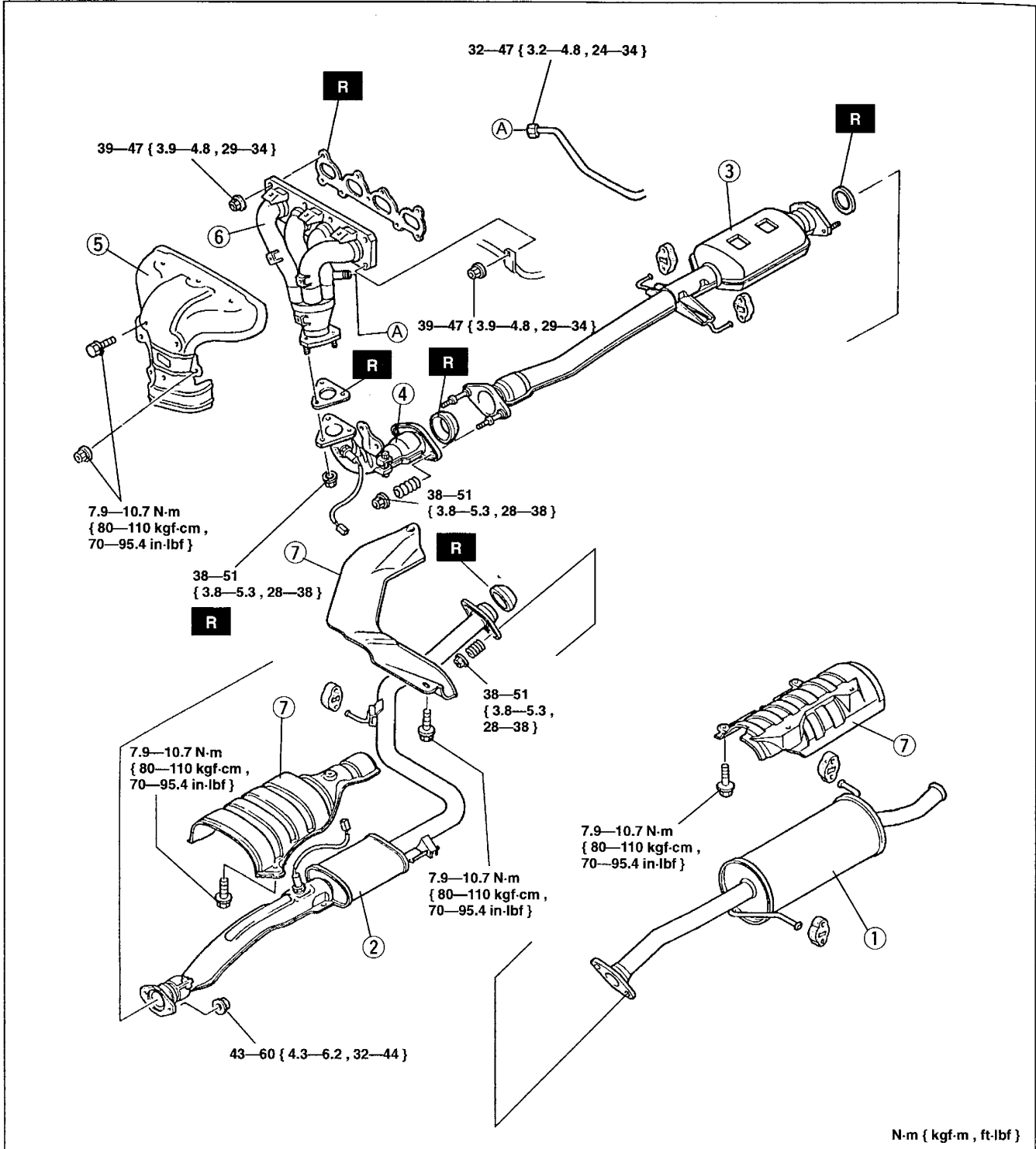

N-m { kgf-m , ft-lbf }

1. Main silencer
2. Presilencer
3. Three way catalytic converter
4. Front pipe
Installation note page F2-27

5. Exhaust manifold insulator
6. Exhaust manifold
Removal note page F2-27
7. Insulator

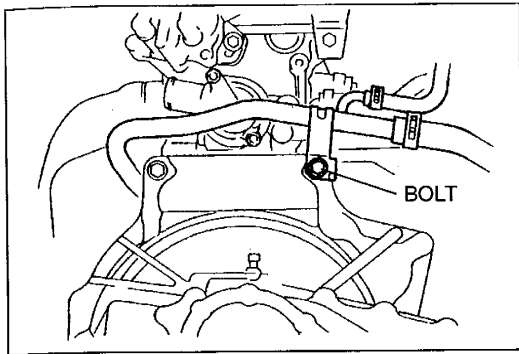
**Removal note****Exhaust manifold**

1. Remove the air cleaner and disconnect the air hose. (Refer to page F2-5.)
2. Remove the water bypass pipe stay bolt.

Tightening torque:

64—89 N·m { 6.5—9.1 kgf·m , 48—65 ft·lbf }

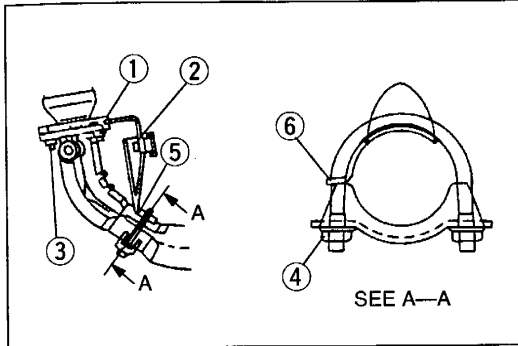
**Installation note****Front pipe**

1. Hand tighten bolts and nuts in the order shown.
2. Tighten nut ③.

Tightening torque:

38—51 N·m { 3.8—5.3 kgf·m , 28—38 ft·lbf }

3. Check for correct alignment at ⑤ (front pipe and bracket) and at ② (block and bracket).
4. Check for correct alignment at ⑥ (hanger bracket and U bolt), then tighten nut ④.

Tightening torque:

10—16 N·m { 100—170 kgf·cm , 87—147 in·lbf }

5. Verify that ③ (flange and bracket) contacts with ② (block and bracket), then tighten nut ①.

Tightening torque:

19—25 N·m { 1.9—2.6 kgf·m , 14—18 ft·lbf }

6. Tighten bolt ②.

Tightening torque:

38—51 N·m { 3.8—5.3 kgf·m , 28—38 ft·lbf }

EMISSION SYSTEM

COMPONENT PARTS

Removal / Installation

Fuel tank side

1. Remove the fuel tank. (Refer to page F2-12, 13.)
2. Remove in the order shown in the figure.
3. Install in the reverse order of removal, referring to **Installation note**.

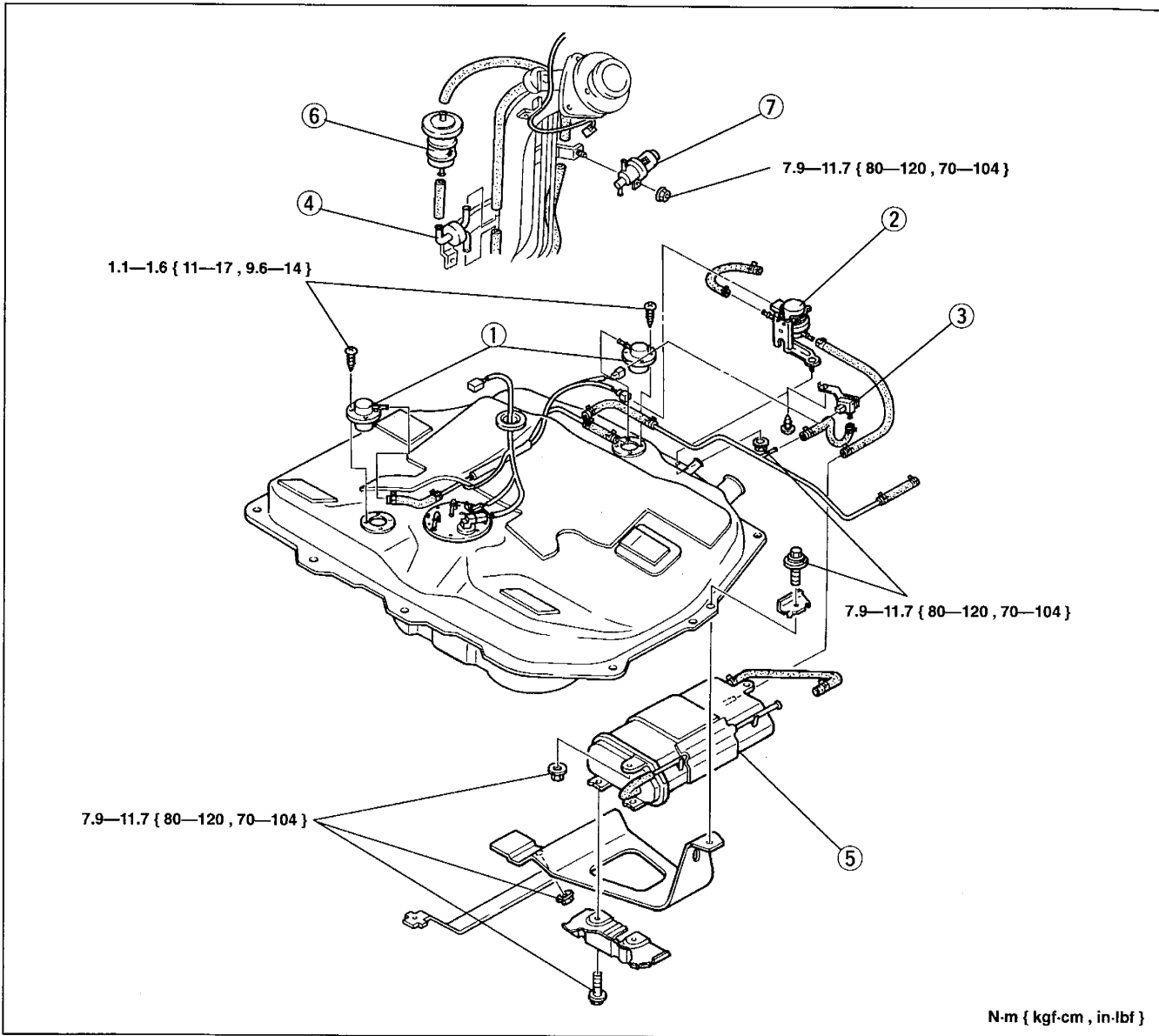

1. Rollover valve
Installation note page F2-29
2. Tank pressure control valve (TPCV)
Installation note page F2-29
3. Fuel tank pressure sensor
4. Check valve (two-way)
Installation note page F2-29

5. Charcoal canister
Installation note page F2-29
6. Air filter
7. Canister drain cut valve (CDCV)

Installation note**Rollover valve, check valve (two-way), tank pressure control valve, charcoal canister**

- Push the ends of the evaporative hoses onto respective fittings.

Specification: 15—20 mm { 0.60—0.78 in }
(except charcoal canister)
: 25—30 mm { 0.99—1.18 in }
(charcoal canister)

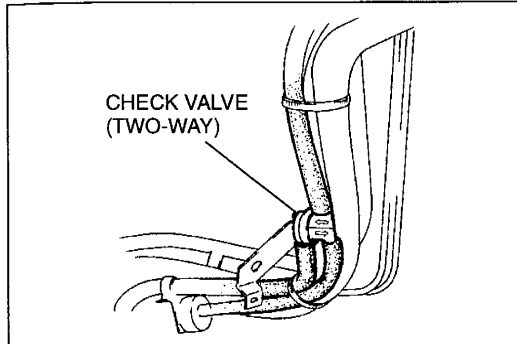
**Check valve (two-way)**

- Push the end of the evaporative hose onto the fitting.

Specification: 15—20 mm { 0.60—0.78 in }

- Install the check valve (two-way) in the correct direction as shown.

Engine compartment side

1. Disconnect the negative battery cable.
2. Remove in the order shown in the figure.
3. Install in the reverse order of removal.

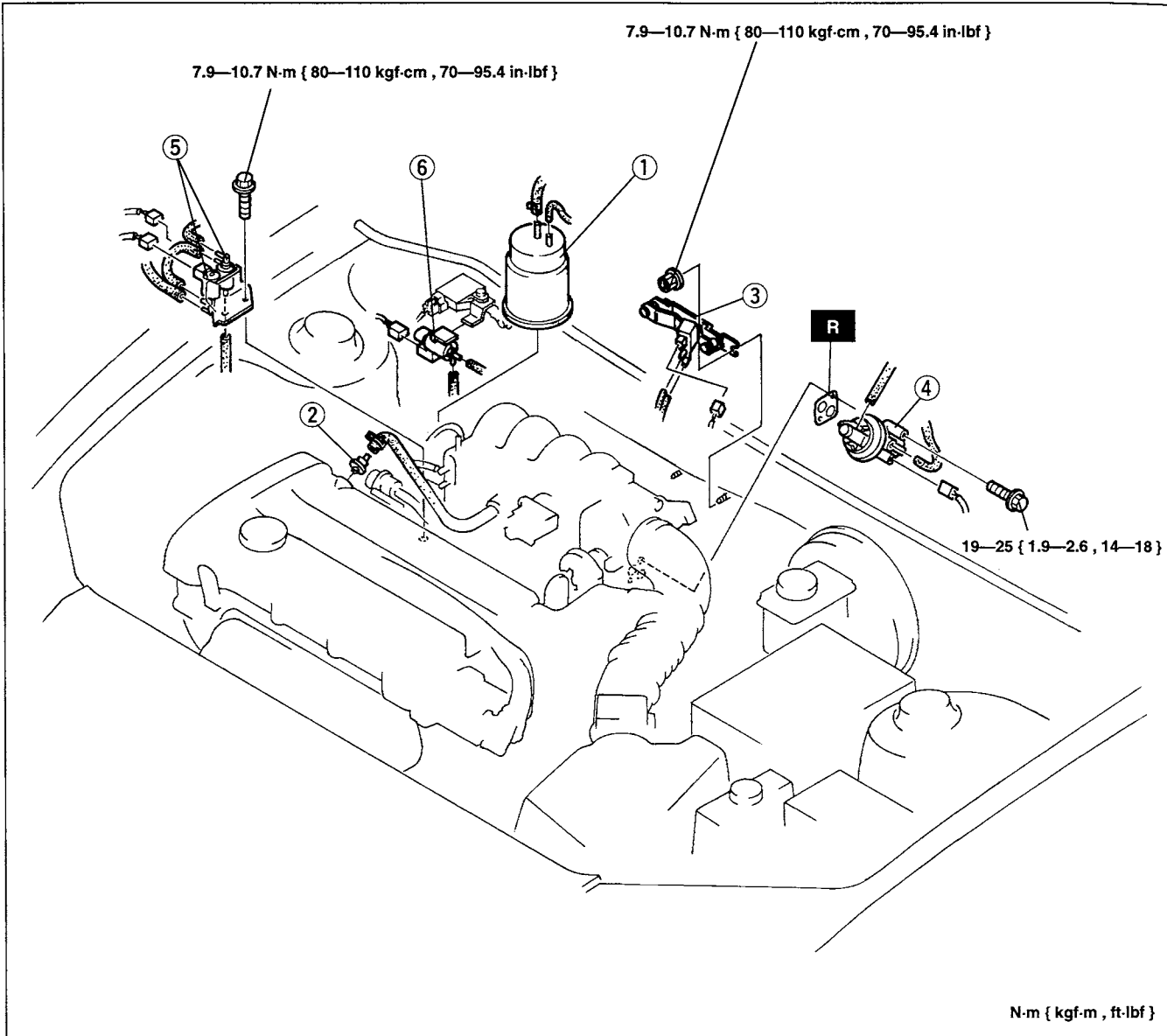

- | | |
|-------------------------|------------------------------------|
| 1. Catch tank | 4. EGR valve |
| 2. PCV valve | 5. EGR solenoid valve |
| 3. Purge solenoid valve | 6. EGR boost sensor solenoid valve |

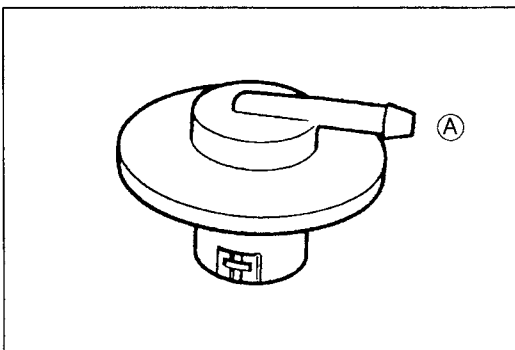

ROLLOVER VALVE

Inspection

1. Remove the fuel tank. (Refer to page F2-12, 13.)
2. Remove the rollover valve. (Refer to page F2-28.)
3. Verify that air flows through the valve from port **A** when the valve is held as shown.

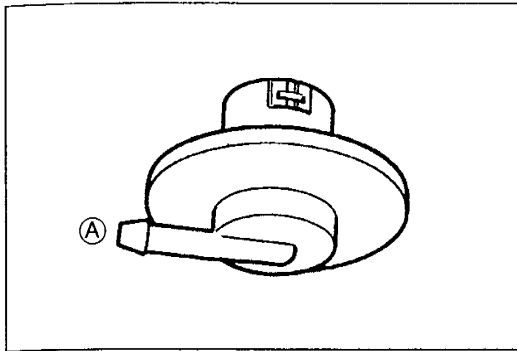

4. Verify that no air flows through the valve from port ① when the valve is held as shown.
5. If not as specified, replace the rollover valve.

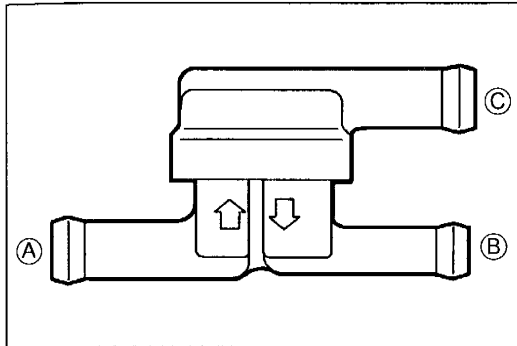

CHECK VALVE

Inspection

Two-way

1. Remove the check valve (two-way). (Refer to page F2-28.)
2. Blow air into port ① and verify that air smoothly flows from port ③.
3. Blow air into port ③ and verify that air smoothly flows from port ②.
4. If not as specified, replace the check valve (two-way).

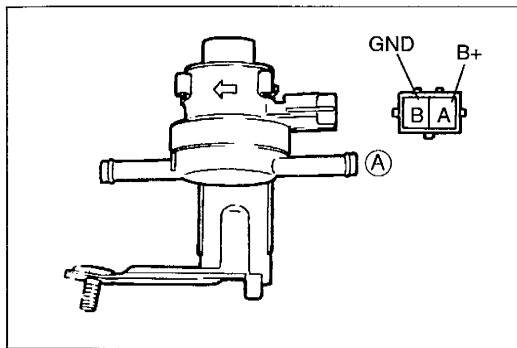

TANK PRESSURE CONTROL VALVE (TPCV)

Inspection

1. Remove the TPCV. (Refer to page F2-28.)
2. Apply pressure or vacuum to port ① of the valve by using a vacuum pump, and check for the air flow.

Specification

Condition	kPa { mmHg , inHg }	Air flow
Pressure	Below 1.96 { 1.47 , 0.06 }	No
	Above 9.81 { 7.36 , 0.29 }	Yes
Vacuum	Below 9.81 { 7.36 , 0.29 }	Yes

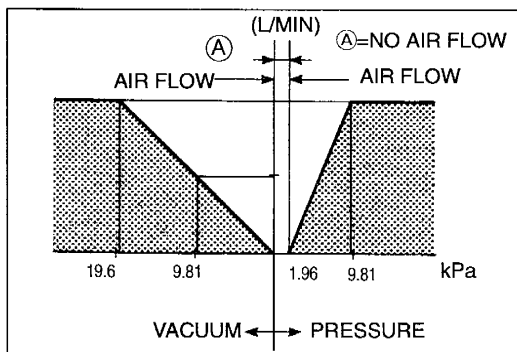

3. Apply battery positive voltage to the valve connector and apply pressure to port ①, and verify that air flows smoothly.
4. If not as specified, replace the TPCV.

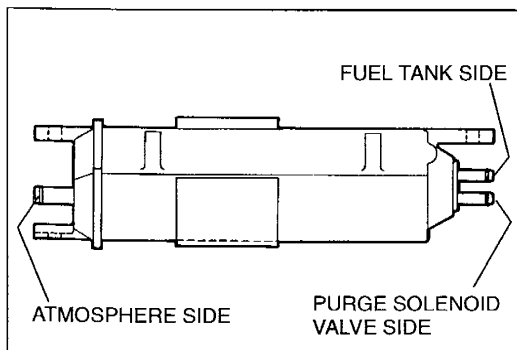

CHARCOAL CANISTER

Inspection

1. Remove the charcoal canister. (Refer to page F2-28.)
2. Plug the charcoal canister atmosphere side port and purge solenoid valve side port.
3. Blow air into the charcoal canister and verify that no air leaks.
4. If air leaks, replace the charcoal canister.

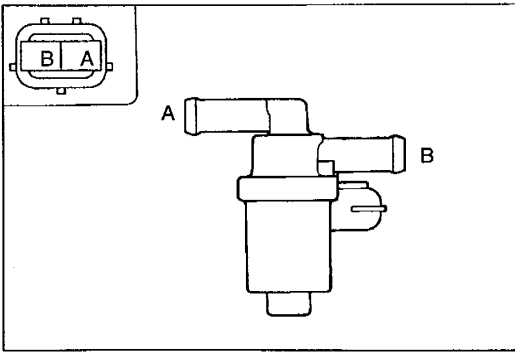

CANISTER DRAIN CUT VALVE (CDCV)

Inspection

1. Remove the valve. (Refer to page F2-28.)
2. Check for air flow between ports of the solenoid valve.
 ○—○: Continuity ○=○: Air flow B+: Battery positive voltage

Step	Terminal		Port	
	A	B	A	B
1	○—○	○—○	○=○	○=○
2	B+	Ground		

3. If not as specified, replace the canister drain cut valve.

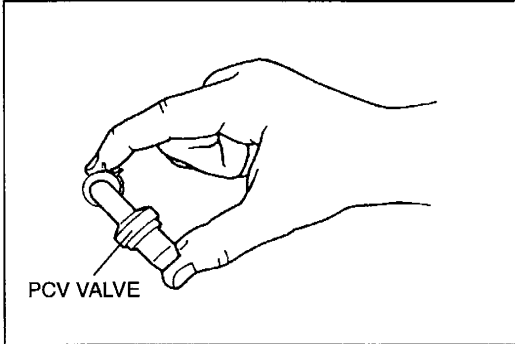

PCV VALVE

Inspection

1. Start the engine and let it idle.
2. Disconnect the PCV valve from the cylinder head cover. (Refer to page F2-30.)
3. Block the valve opening by hand and verify that vacuum is felt.
4. If not, check the PCV hose for clogging and damage. If the hose is OK, replace the PCV valve.

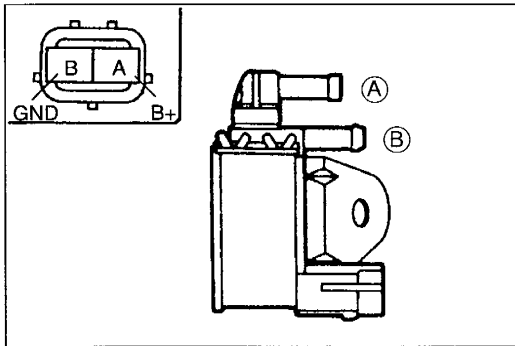

PURGE SOLENOID VALVE

Inspection

1. Remove the purge solenoid valve. (Refer to page F2-30.)
2. Check for air flow between ports of the solenoid valve.
 ○—○: Continuity ○=○: Air flow B+: Battery positive voltage

Step	Terminal		Port	
	A	B	A	B
1	○—○	○—○		
2	B+	Ground	○=○	○=○

3. If not as specified, replace the purge solenoid valve.

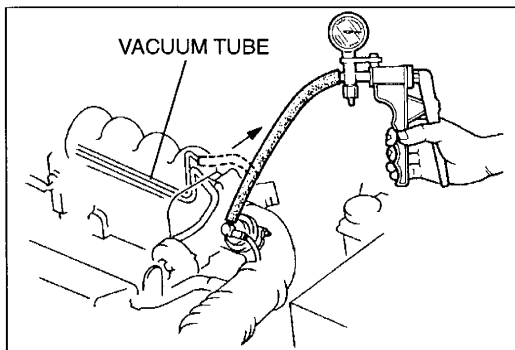

EGR VALVE

Inspection

1. Start the engine and let it idle.
2. Disconnect the vacuum hose from the vacuum tube and install a vacuum pump to the valve.
3. Verify that the engine runs roughly or stalls at the specified vacuum.

Specification:

8.7—10.6 kPa { 65—79 mmHg , 2.6—3.1 inHg }

4. If not as specified, replace the EGR valve. (Refer to page F2-30.)

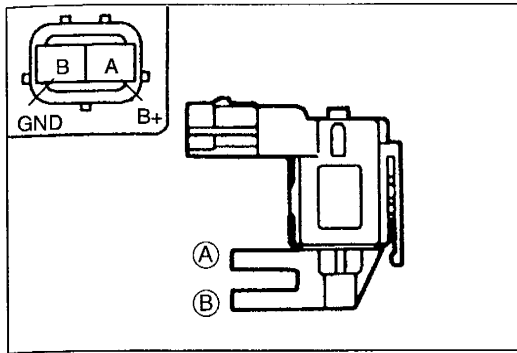

EGR SOLENOID VALVE

Inspection

EGR solenoid valve (vacuum)

1. Remove the EGR solenoid valve (vacuum).
(Refer to page F2-30.)
2. Check for air flow between ports of the solenoid valve.

○—○: Continuity ○=○: Air flow B+: Battery positive voltage

Step	Terminal		Port	
	A	B	A	B
1	○—○	○—○		
2	B+	Ground	○=○	○=○

3. If not as specified, replace the EGR solenoid valve (vacuum).

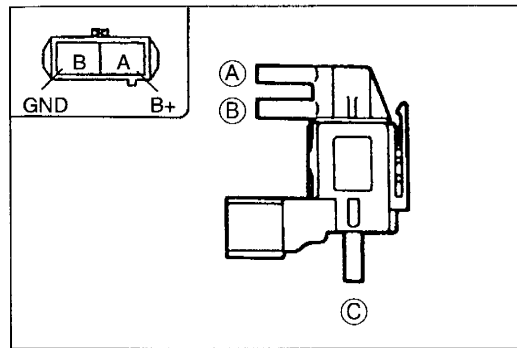

EGR solenoid valve (vent)

1. Remove the EGR solenoid valve (vent).
(Refer to page F2-30.)
2. Check for air flow between ports of the solenoid valve.

○—○: Continuity ○=○: Air flow B+: Battery positive voltage

Step	Terminal		Port		
	A	B	A	B	C
1	○—○	○—○	○=○	○=○	○=○
2	B+	Ground	○=○	○=○	

3. If not as specified, replace the EGR solenoid valve (vent).

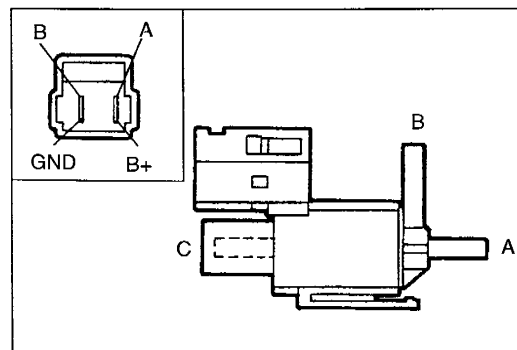

EGR BOOST SENSOR SOLENOID VALVE

Inspection

1. Remove the EGR boost sensor solenoid valve.
(Refer to page F2-30.)
2. Check for air flow between ports of the solenoid valve.

○—○: Continuity ○=○: Air flow B+: Battery positive voltage





Step	Terminal		Port		
	A	B	A	B	C
1	○—○	○—○		○=○	○=○
2	B+	Ground	○=○	○=○	

3. If not as specified, replace the EGR boost sensor solenoid valve.

CONTROL SYSTEM

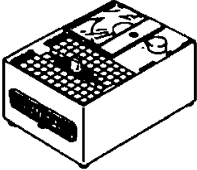
PREPARATION

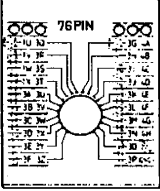
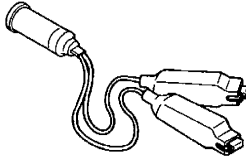
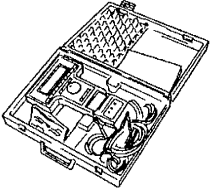
SST

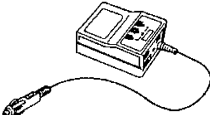
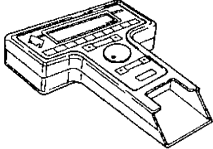
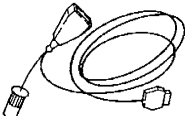
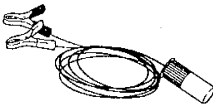
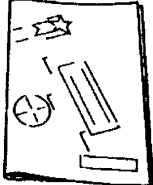
<p>49 9200 162A Engine Signal Monitor</p> 	<p>For inspection of PCM terminal voltage</p>	<p>49 T018 902 Harness adapter</p> 	<p>For inspection of PCM terminal voltage</p>
<p>49 F018 903 Sheet</p> 	<p>For inspection of PCM terminal voltage</p>	<p>49 D088 008 Harness adapter, Power</p> 	<p>For inspection of PCM terminal voltage</p>
<p>49 T088 0A0 NGS set</p> 	<p>For inspection of PCM and input/output devices</p>	<p>49 T088 010B Program Card</p> 	<p>For inspection of PCM and input/output devices</p>
<p>49 T088 002 Vehicle Interface Module (Part of 49 T088 0A0)</p> 	<p>For inspection of PCM and input/output devices</p>	<p>49 T088 001 Control Unit (Part of 49 T088 0A0)</p> 	<p>For inspection of PCM and input/output devices</p>
<p>49 T088 004 NGS OBDII Adapter (Part of 49 T088 0A0)</p> 	<p>For inspection of PCM and input/output devices</p>	<p>49 T088 006 Battery Hookup Adapter (Part of 49 T088 0A0)</p> 	<p>For inspection of PCM and input/output devices</p>
<p>49 T088 008A Instruction Manual</p> 	<p>For inspection of PCM and input/output devices</p>	<p>—</p>	<p>—</p>

COMPONENT PARTS

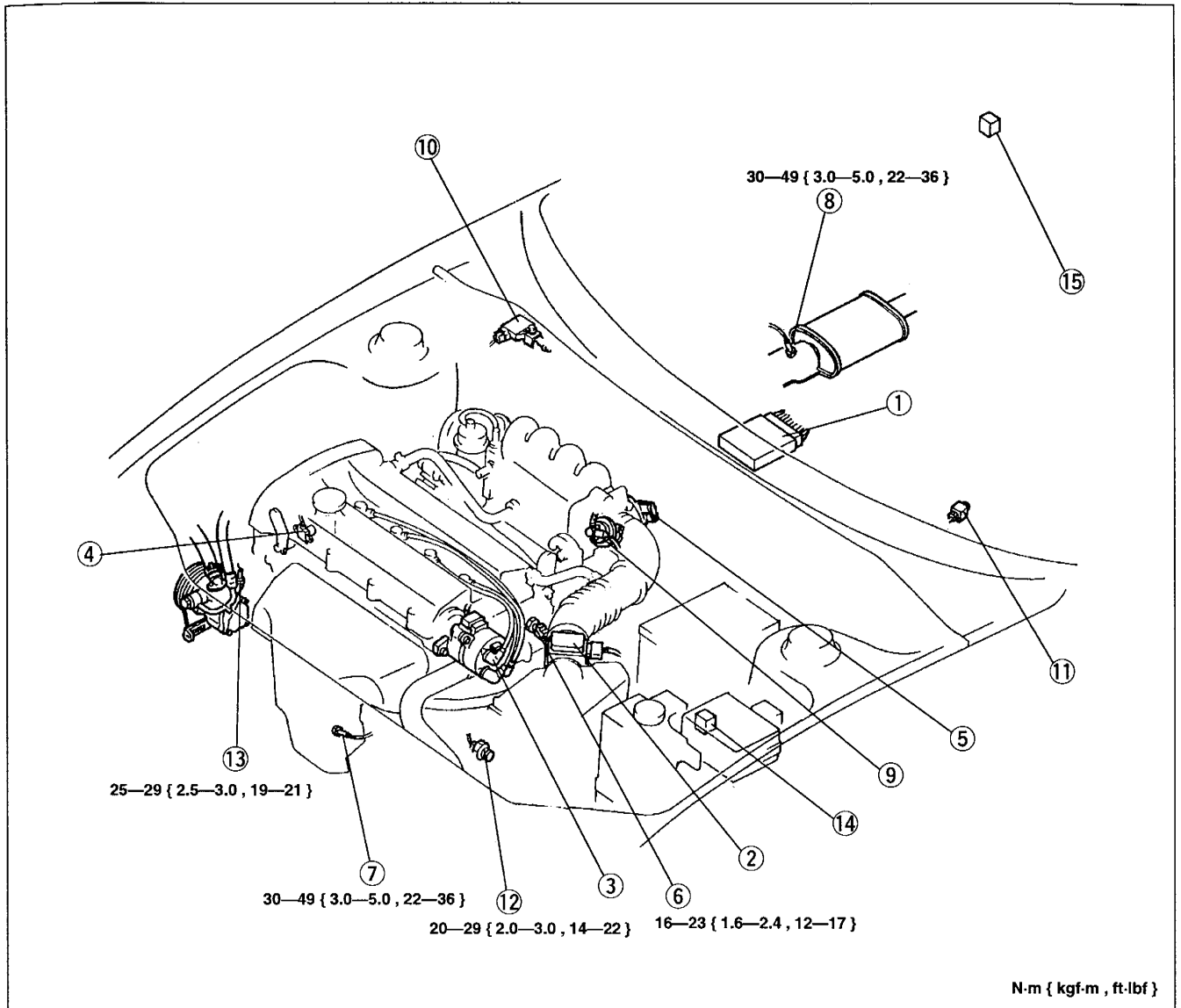

N-m { kgf-m , ft-lbf }

- | | |
|---|---|
| <p>1. Powertrain control module (PCM)
 Removal / Installation page F2-36
 Inspection page F2-37</p> <p>2. Mass air flow sensor
 (Include intake air temperature sensor)
 Inspection page F2-44
 Removal / Installation page F2- 5</p> <p>3. Camshaft position sensor
 Inspection page F2-45</p> <p>4. Crankshaft position sensor
 Inspection page F2-45
 Replacement page F2-46</p> <p>5. Throttle position sensor
 Inspection page F2-46
 Adjustment page F2-47
 Replacement page F2-48</p> <p>6. Engine coolant temperature sensor
 Inspection page F2-48</p> <p>7. Heated oxygen sensor (Front)
 Inspection page F2-48</p> | <p>8. Heated oxygen sensor (Rear)
 Inspection page F2-48</p> <p>9. EGR valve position sensor
 Inspection page F2-49</p> <p>10. EGR boost sensor
 Inspection page F2-50</p> <p>11. Clutch switch
 Inspection page F2-52
 Replacement page F2-52</p> <p>12. Neutral switch
 Inspection page F2-52</p> <p>13. Power steering pressure switch
 Inspection page F2-52</p> <p>14. Main relay
 Inspection page F2-53</p> <p>15. Fuel tank pressure sensor
 Inspection page F2-51</p> |
|---|---|

POWERTRAIN CONTROL MODULE (PCM)

Removal / Installation

1. Disconnect the negative battery cable.
2. Remove the rear console, front console and undercover. (Refer to section S.)
3. Remove in the order shown in the figure.
4. Install in the reverse order of removal.

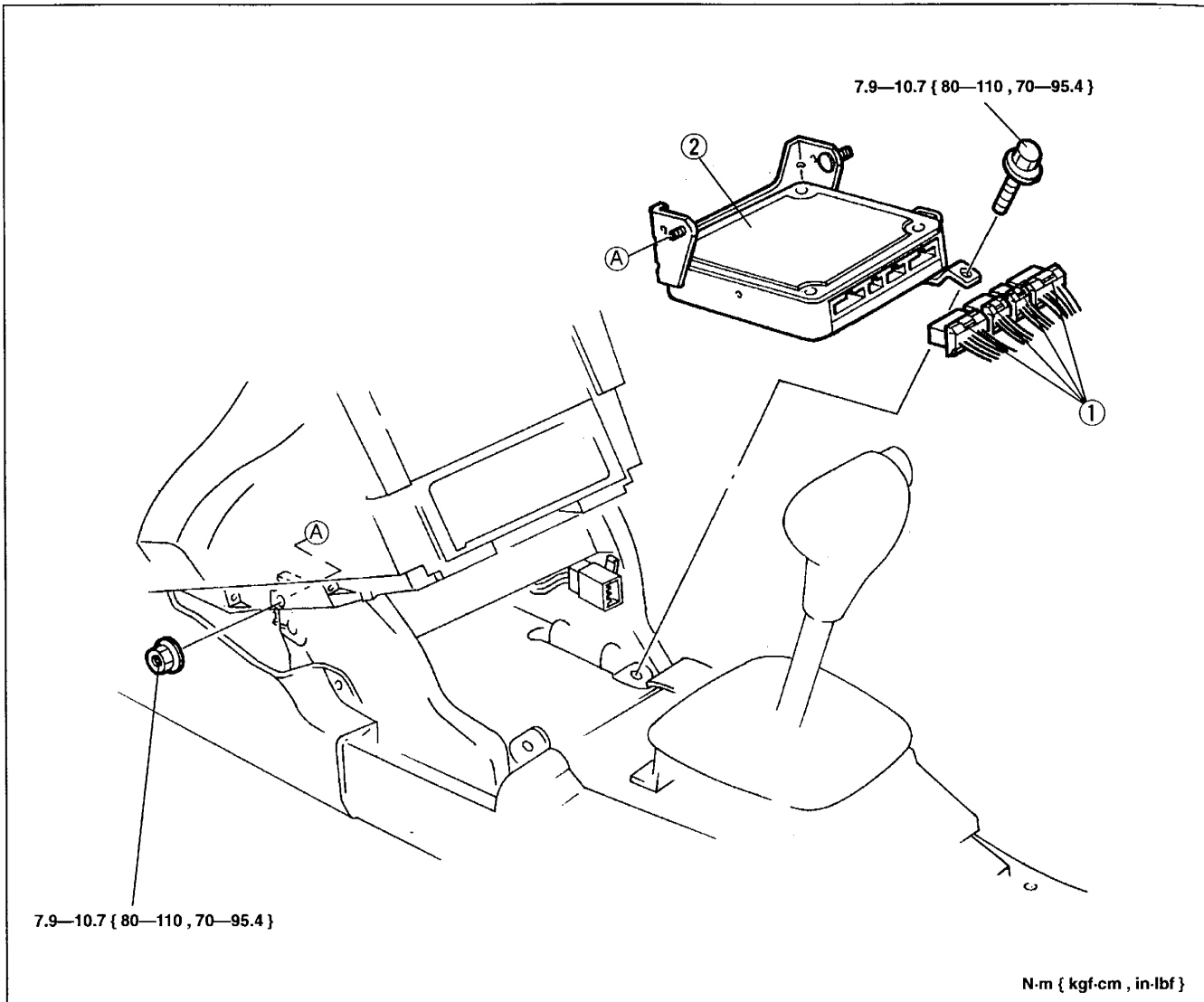

1. PCM connectors

2. Powertrain control module (PCM)

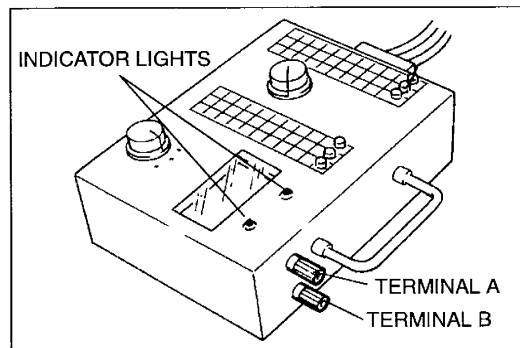
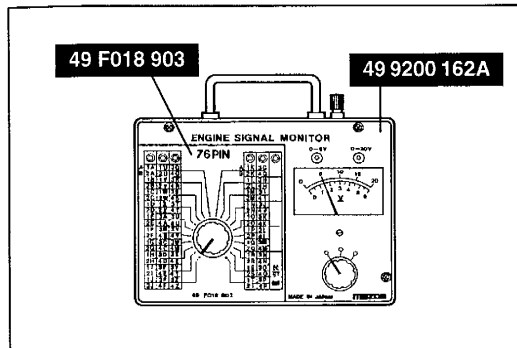
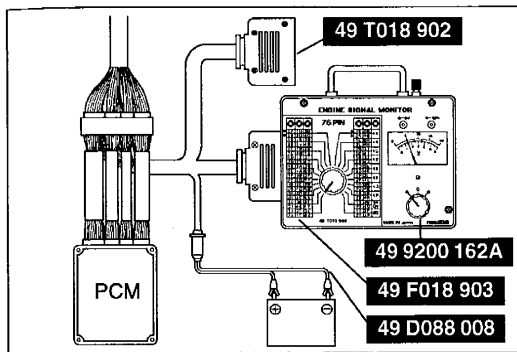

Inspection

Caution

- The PCM terminal voltages vary with change in measuring conditions and vehicle conditions. Always carry out a total inspection of the input systems, output systems, and PCM to determine the cause of trouble. Otherwise, a wrong diagnosis will be made.

1. Disconnect the negative battery cable.
2. Remove the rear console, front console and undercover. (Refer to section S.)
3. Disconnect the PCM connector.
4. Connect the **SST** (Harness adapter) to the PCM connector.
5. Connect the **SSTs** (Engine Signal Monitor and Harness adapter, power) to the **SST** (Harness adapter). Use connector A of the harness adapter for PCM terminals 1A through 1V and 3A through 3P. Use connector B for PCM terminals 2A through 2L and 4A through 4Z.
6. Place the **SST** (Sheet) on the **SST** (Engine Signal Monitor).
7. Measure the voltage at each PCM terminal by switching the selector switch and the monitor switch.
8. If any incorrect voltage is detected, check related systems, wiring harnesses and connectors referring to the possible malfunction in the terminal voltage list.

Caution

- Disconnecting the connectors of the PCM and the **SST** (Harness adapter) while the battery is connected can damage the PCM and the **SST** (Engine Signal Monitor). Disconnect the negative battery cable and the **SST** (Harness adapter, power) before disconnecting the connectors.
- Applying voltage to terminals A and B of the **SST** (Engine Signal Monitor) can damage the **SST** (Engine Signal Monitor).

Note

- The indicator lights of the **SST** (Engine Signal Monitor), provided for confirmation of the voltmeter range, is also used for detection of the pulse such as the fuel injector control signal, which is difficult to detect by using the voltmeter.
- Terminals A and B of the **SST** (Engine Signal Monitor) are for connection of an external instrument. By connecting an external instrument such as a circuit tester or an oscilloscope, various inspections in addition to the measurement of the PCM terminal voltages are made possible.

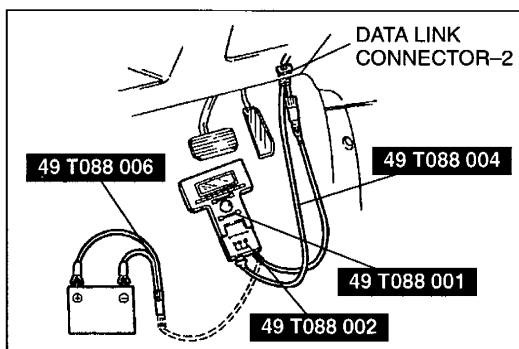

Using the SSTs (NGS)

1. In the passenger compartment, connect the **SSTs** (NGS) to the data link connector-2 as shown in the figure.
2. Referring to the NGS instruction manual, select the "PID/DATA MONITOR AND RECORD" function.
3. Referring to the 1996 Service Highlights, inspect each PCM input/output signal.

Note

- The "PID/DATA MONITOR AND RECORD" function is to monitor the calculation value of input/output signals in the PCM. Deviation in the value does not always indicate malfunction in the related input/output devices.
- When normal output signal cannot be detected when all input signals are normal, replace the PCM.

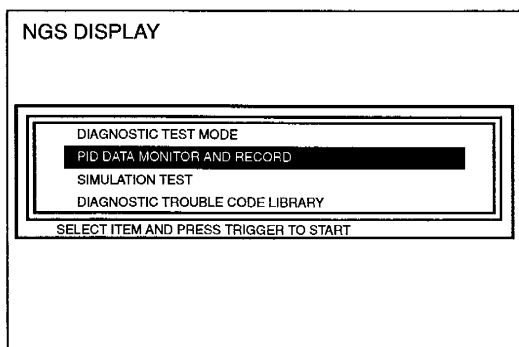

Terminal voltage (Reference)

B+: Battery positive voltage
 *1: In data link connector
 *2: ATX only

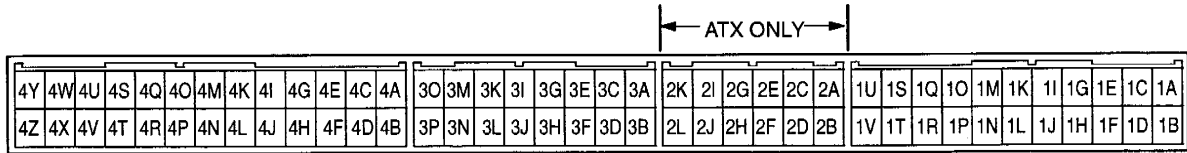

Terminal	Signal	Connected to	Test condition		Voltage (V)	Possible malfunction
1A	Cooling fan control	Cooling fan relay	Ignition switch ON	Cooling fan operating/ Terminal *1TEN ground and throttle valve open	Below 1.0	• Cooling fan relay (Refer to section E)
				Cooling fan stop	B+	
1B*2	Condenser fan control	Condenser fan relay	Idle	Condenser fan operating	Below 1.0	• Condenser fan relay (Refer to section U)
				Condenser fan stop	B+	
1C	—	—	—		—	—
1D	Serial communication	Data link connector—2 terminal KLN	Carry out inspection according to diagnostic trouble code Diagnostic trouble code output is a part of serial communication Judgement by terminal voltage is not possible (Refer to page F2-54)		—	• On-board diagnostic system
1E	MIL	Malfunction indicator lamp	Malfunction indicator lamp OFF		B+	• PCM terminal 1E — MIL
			Malfunction indicator lamp ON		Below 2.0	
1F	—	—	—		—	—
1G	A/C control	A/C relay	Ignition switch ON		B+	• A/C relay (Refer to section U)
			Idle	A/C operating	Below 2.0	
				A/C stop	B+	
1H	Headlight	Headlight switch	Headlight switch OFF		Below 1.0	• Headlight switch (Refer to section T)
			Headlight switch ON		B+	
1I	Diagnostic test mode	Data link connector (Terminal TEN)	Ignition switch ON	Open terminal *1TEN	B+	• PCM terminal 1I – *1TEN harness
				Short terminal *1TEN	Below 1.0	
1J	Rear window defroster	Rear window defroster switch	Ignition switch ON	Rear window defroster switch OFF	Below 1.0	• Rear window defroster switch (Refer to section T)
				Rear window defroster switch ON	B+	
1K	A/C	A/C amplifier	Idle	A/C switch and fan switch ON	Approx. 2.0	• A/C switch • Refrigerant pressure switch • A/C amplifier (Refer to section U)
				A/C switch OFF	B+	
1L	Load/No load distinction	Neutral/clutch switch (MTX), Transaxle range switch (ATX)	Ignition switch ON	MTX Other than neutral position and clutch pedal released	B+	• Neutral switch (Refer to page F2-52) • Clutch switch (Refer to page F2-52) • Transaxle range switch (Refer to section K)
				ATX Other than P and N positions		
				MTX Neutral position or clutch pedal depressed	Below 1.0	
				ATX P or N position		

B+: Battery positive voltage

*1: In data link connector

*2: ATX only

Terminal	Signal	Connected to	Test condition		Voltage (V)	Possible malfunction
1M	Vehicle speed	Vehicle speed sensor	Ignition switch ON		0 or 4.0	• Vehicle speed sensor (Refer to section T)
			Driving		Approx. 3.0	
1N	DRL (CANADA)	DRL relay	Daytime running light ON		Below 2.0	• DRL relay (Refer to section T)
			Daytime running light OFF		B+	
1O	—	—	—		—	—
1P	Blower	Fan switch	Ignition switch ON	Fan switch OFF or ON at 1st	B+	• Fan switch (Refer to section U)
				Fan switch ON at 2nd or higher	Below 1.0	
1Q	Brake	Brake switch	Brake pedal released		Below 1.0	• Brake switch (Refer to section P)
			Brake pedal depressed		B+	
1R	—	—	—		—	—
1S	—	—	—		—	—
1T	—	—	—		—	—
1U	Fuel pump control	Fuel pump relay	Ignition switch ON		B+	• Fuel pump relay (Refer to page F2-24)
			Cranking		Below 2.0	
			Idle			
1V	—	—	—		—	—
*22A	Shift solenoid A control	Shift solenoid A	During shifting		B+	• Shift solenoid A (Refer to section K)
			Others		Below 1.0	
*22B	Shift solenoid B control	Shift solenoid B	During shifting		B+	• Shift solenoid B (Refer to section K)
			Others		Below 1.0	
*22C	Shift solenoid C control	Shift solenoid C	During shifting		B+	• Shift solenoid C (Refer to section K)
			Others		Below 1.0	
*22D	Torque converter clutch solenoid valve control	Torque converter clutch solenoid valve	During shifting		B+	• Torque converter clutch solenoid valve (Refer to section K)
			Others		Below 1.0	
*22E	O/D OFF indicator light control	O/D OFF indicator light	Ignition switch ON	O/D OFF mode	Below 2.0	• Instrument cluster (O/D OFF indicator) (Refer to section K)
				Others	B+	
*22F	D range	Transaxle range switch (D range)	Idle	D range	B+	• Transaxle range switch (Refer to section K)
				Others	Below 1.0	
*22G	2 range	Transaxle range switch (2 range)	Idle	2 range	B+	
				Others	Below 1.0	
*22H	1 range	Transaxle range switch (1 range)	Idle	1 range	B+	
				Others	Below 1.0	
*22I	O/D OFF switch	O/D OFF switch	Ignition switch ON	O/D OFF switch pressed	Below 1.0	• O/D OFF switch (Refer to section K)
				O/D OFF switch released	B+	
2J	—	—	—		—	—
*22K	Input/turbine speed sensor	Input/turbine speed sensor (turbine)	Ignition switch ON		Approx. 1.0	• Input/turbine speed sensor (Refer to section K)
			Idle			
*22L	Input/turbine speed sensor ground	Input/turbine speed sensor (ground)	Constant		Below 1.0	• PCM 2L terminal continuity harness (Refer to section K)

B+: Battery positive voltage
 *1: In data link connector
 *2: ATX only

Terminal	Signal	Connected to	Test condition		Voltage (V)	Possible malfunction
3A	Fuel tank pressure	Fuel tank pressure sensor	Ignition switch ON	Fuel tank pressure 0 kPa { 0 mmHg , 0 inHg } (Barometric pressure)	Approx. 2.5	• Fuel tank pressure sensor (Refer to page F2-51)
3B	Mass air flow sensor (VGP)	Mass air flow sensor	Ignition switch ON		Below 1.0	• Mass air flow sensor (Refer to page F2-44)
			Idle		1.0—2.0	
3C	Heated oxygen sensor (Front)	Heated oxygen sensor (Front)	Ignition switch ON		Approx. 0	• Heated oxygen sensor (Front) (Refer to page F2-48)
			Idle	Engine cold	0.1—0.9	
				After warm up	Below 1.0	
			Acceleration	0.5—1.0		
Deceleration	0—0.5					
3D	Heated oxygen sensor (Rear)	Heated oxygen sensor (Rear)	Ignition switch ON		Approx. 0	• Heated oxygen sensor (Rear) (Refer to page F2-48)
			Idle	Engine cold	Below 1.0	
				After warm up	Below 1.0	
			Acceleration	0—1.0		
Deceleration	0—1.0					
*23E	Transaxle fluid temperature	Trasaxle fluid temperature sensor	Ignition switch ON	Transaxle fluid temperature 20 °C { 68 °F }	Approx. 4.0	• Transaxle fluid temperature sensor (Refer to section K)
				Transaxle fluid temperature 130 °C { 266 °F }	Approx. 1.5	
3F	Throttle position (TVO)	Throttle position sensor	Ignition switch ON	Closed throttle position	0.3—1.0	• Throttle position sensor (Refer to page F2-46) • PCM terminal 3I voltage
				Wide open throttle	2.8—4.5	
3G	Engine coolant temperature	Engine coolant temperature sensor	Ignition switch ON	Engine coolant temp 20 °C { 68 °F }	Approx. 3.1	• Engine coolant temperature sensor (Refer to page F2-48)
				After warm up	Below 1.0	
3H	EGR boost/ Barometric pressure	EGR boost sensor	Ignition switch ON		Approx. 4.5	• EGR boost sensor (Refer to page F2-51)
			Idle			
3I	Constant voltage (Vref)	Throttle position sensor EGR valve position sensor	Ignition switch ON		Approx. 5.0	• PCM terminal 4B voltage
3J	EGR valve position	EGR valve position sensor	Ignition switch ON		Approx. 0.8	• EGR valve position sensor (Refer to page F2-49) • PCM terminal 3I voltage
			Idle			
3K	Intake air temperature	Intake air temprature sensor	Ignition switch ON	Intake air temperature 20 °C { 68 °F }	Approx. 2.5	• Mass air flow sensor (Refer to page F2-44)
3L	—	—	—		—	—
3M	Heated oxygen sensor heater	Heated oxygen sensor (Front)	Ignition switch ON	Idle	Below 2.0	• Heated oxygen sensor (Refer to page F2-48)
3N	—	—	—		—	—
3O	Analogue sensor ground	Ground	Constant		Below 1.0	• PCM 3O terminal harness (Open)
3P	Power steering pressure	Power steering pressure switch	Ignition switch ON		B+	• Power steering pressure switch (Refer to page F2-53)
			Idle	P/S not operating		
P/S operating	Below 1.0					

B+: Battery positive voltage

*1: In data link connector

*2: ATX only

Terminal	Signal	Connected to	Test condition		Voltage (V)	Possible malfunction
4A	PCM ground	Ground	Constant		Below 1.0	• PCM 4A harness (Open)
4B	Power supply	Main relay (FUEL INJ relay)	Ignition switch	OFF	Below 1.0	• Main relay (Refer to page F2-53)
				ON	B+	
4C	Fuel injector ground	Ground	Constant		Below 1.0	• PCM 4C terminal continuity harness (Open)
4D	Output device ground	Ground	Constant		Below 1.0	• PCM 4D terminal continuity harness (Open)
4E	NE \ominus	Crankshaft position sensor	Ignition switch ON		Below 1.0	• Crankshaft position sensor (Refer to page F2-45)
			Idle		Below 1.0	
4F	SGT	Camshaft position sensor (In distributor)	Ignition switch ON		0 or Approx. 5.0	• Camshaft position sensor (Refer to page F2-45)
			Idle		Approx. 2.0	
4G	—	—	—		—	—
4H	NE \oplus	Crankshaft position sensor	Ignition switch ON		Below 1.0	• Crankshaft position sensor (Refer to page F2-45)
			Idle		Below 1.0	
4I	Back-up power supply	Battery	Constant		B+	• PCM 4I terminal — battery harness and connector
*24J	Pressure regulator control	PRC solenoid valve	Idle (After hot start approx. 149 sec)		Below 3.0	• PRC solenoid valve (Refer to page F2-24)
			Other		B+	
4K	VICS control	VICS solenoid valve	Ignition switch ON	Engine speed below 4900 rpm	Below 1.0	• VICS solenoid valve (Refer to page F2-9)
				Engine speed above 4900 rpm	B+	
4L	EGR boost sensor switching control	EGR boost sensor solenoid valve	Ignition switch ON		Below 3.0	• EGR boost sensor solenoid valve (Refer to page F2-33)
			Idle			
4M	Fuel level	Fuel gauge sender unit	Ignition switch ON	full fuel	Approx. 6	• Fuel gauge sender unit (Refer to section T)
				low fuel	Approx. 0	
4N	IGT	Ignition control module (In distributor)	Ignition switch ON		Below 1.0	• Ignition control module (Refer to section G)
			Idle		Approx. 0.3	
4O	EGR control (Vent)	EGR solenoid valve (Vent)	Ignition switch ON		B+	• EGR solenoid valve (Vent) (Refer to page F2-33)
			Idle			
4P	EGR control (Vacuum)	EGR solenoid valve (Vacuum)	Ignition switch ON		B+	• EGR solenoid valve (Vacuum) (Refer to page F2-33)
			Idle			
4Q	Idle air control	Idle air control valve	Ignition switch ON		Below 4.8	• Idle air control valve (Refer to page F2-8)
			Idle	After warm up (No load)	Approx. 10	
4R	—	—	—		—	—
4S	—	—	—		—	—
4T	Purge control	Purge solenoid valve	Ignition switch ON		B+	• Purge solenoid valve (Refer to page F2-32)
			Idle			

B+: Battery positive voltage
 *1: In data link connector
 *2: ATX only

Terminal	Signal	Connected to	Test condition	Voltage (V)	Possible malfunction
4U	Fuel injector control	Fuel injector No.1	Ignition switch ON	B+	<ul style="list-style-type: none"> Fuel injector (Refer to page F2-22)
4V		Fuel injector No.2		Idle	
4W		Fuel injector No.3			
4X		Fuel injector No.4			
4Y	---	---	---	---	---
4Z	CDCV, TPCV control	CDCV, TPCV	Ignition switch ON	B+	<ul style="list-style-type: none"> CDCV (Refer to page F2-32) TPCV (Refer to page F2-32)
			Diagnosis executed	Below 1.0	

* Engine Signal Monitor: Green and red lights flash

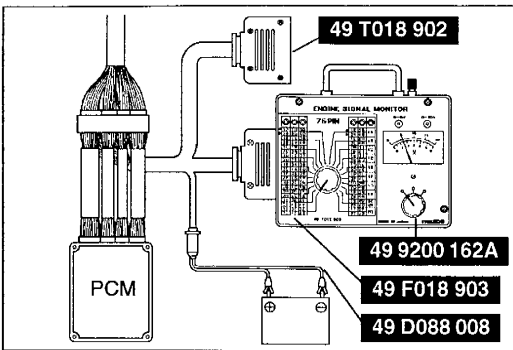

MASS AIR FLOW SENSOR

Inspection

1. Check the mass air flow sensor for damage and cracks.
2. Connect the **SSTs** (Engine Signal Monitor) to the PCM. (Refer to page F2-37.)
3. Measure the voltage at PCM terminal 3B. (Refer to page F2-41.)
4. Verify that the voltage is within the specification.

Specification

Measuring condition	PCM terminal 3B voltage (V)
Ignition switch ON	Below 1.0
Idle	1.0—2.0

5. If not as specified, inspect the harness and connector between the mass air flow sensor and the PCM terminal.
6. If there is correct terminal voltage and harness continuity, replace the mass air flow sensor. (Refer to page F2-5.)

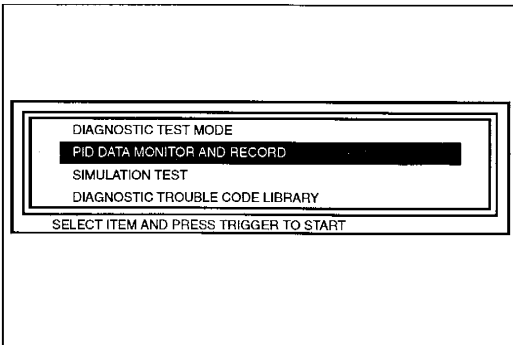

Using the NGS

1. Check the mass air flow sensor for damage and cracks.
2. Connect the **SSTs** (NGS) to the data link connector-2. (Refer to page F2-38.)
3. Select the PID/DATA MONITOR AND RECORD function.
4. Select “MAF V” on the NGS display. The NGS measures and shows the voltage.

Specification

Measuring condition	Mass air flow signal Voltage (V)
Ignition switch ON	Below 1.0
Idle	1.0—2.0

5. If not as specified, inspect the harness and connector between the mass air flow sensor and the PCM terminal.
6. If there is correct terminal voltage and harness continuity, replace the mass air flow sensor. (Refer to page F2-5.)

Note

- The scan tool shows the mass air flow rate and load value.

Specification

	Intake mass air flow (g/s)		Engine load calculated value (%)	
	MTX	ATX	MTX	ATX
Idle	2.0—2.9	2.3—3.1	15.0—19.0	16.7—21.0
Engine speed 2,500 rpm*	6.6—7.8	7.6—8.9	13.7—17.0	16.0—19.0

*: No load, neutral or P position

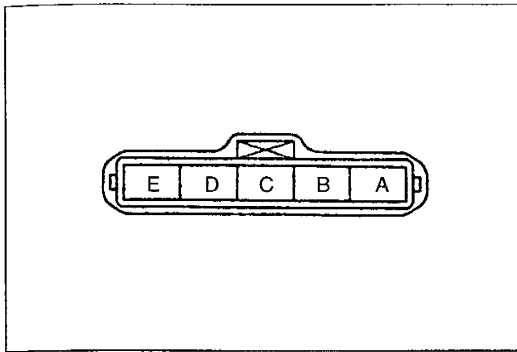
**Intake air temperature sensor**

1. Disconnect the mass air flow sensor connector.
2. Measure the resistance between terminals C and D by using an ohmmeter.

Specification: 2.21—2.69 k Ω [20 °C { 68 °F }]

3. If not as specified, replace the mass air flow sensor. (Refer to page F2-5.)

CAMSHAFT POSITION SENSOR**Inspection**

1. Remove the distributor. (Refer to section G.)
2. Disconnect the fuel injector connector.
3. Connect the distributor connector.

Warning

- Turning the ignition switch on with the fuel injector connector still connected will actuate the fuel injector.
- Turning the ignition switch on with the hightension lead still connected will generate sparks, which can cause electrical shock. Disconnect the hightension lead and avoid it from grounding to the vehicle body.

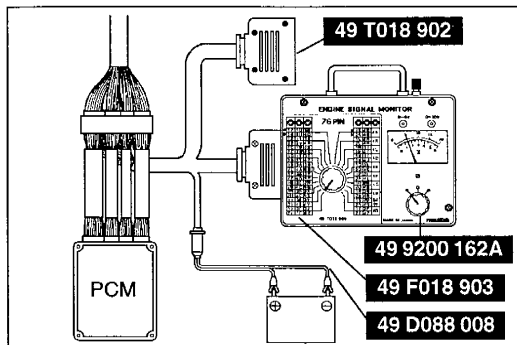

4. Connect the SSTs (Engine Signal Monitor) to the PCM. (Refer to page F2-37.)
5. Turn the ignition switch to ON.
6. Measure the voltage at PCM terminal 4F.
7. Rotate the distributor drive by hand and check the output signal.

Specification

PCM terminal	Signal	
4F	SGT	Approx. 5 V (4 pulses/rev)

8. If not as specified, inspect the wiring harness and connector between the distributor and the PCM terminal.
9. If there is correct terminal voltage and harness continuity, replace the distributor. (Refer to section G.)

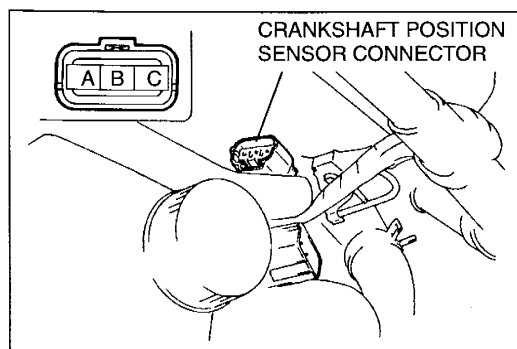
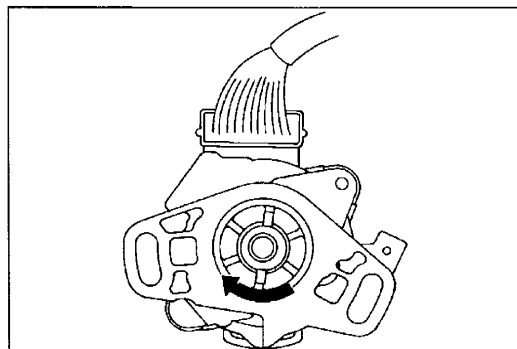
**CRANKSHAFT POSITION SENSOR****Inspection****Resistance**

1. Disconnect the crankshaft position sensor connector.
2. Measure the resistance between terminals A and B by using an ohmmeter.

Specification: 500—600 Ω [20 °C { 68 °F }]

3. If not as specified, replace the crankshaft position sensor. (Refer to page F2-46.)

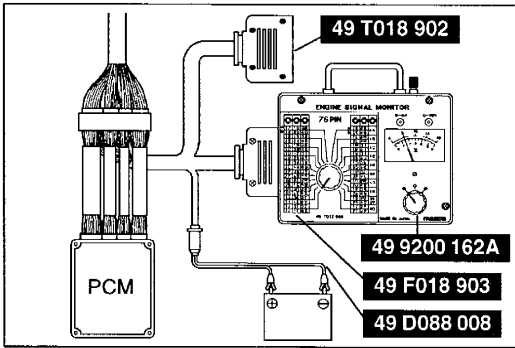
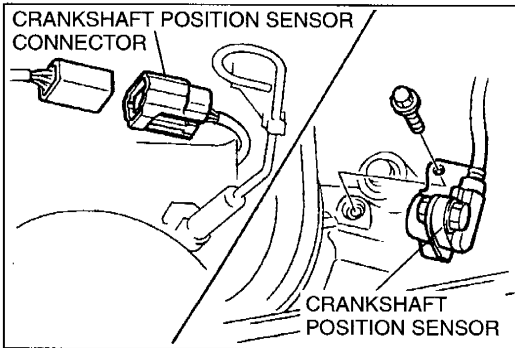
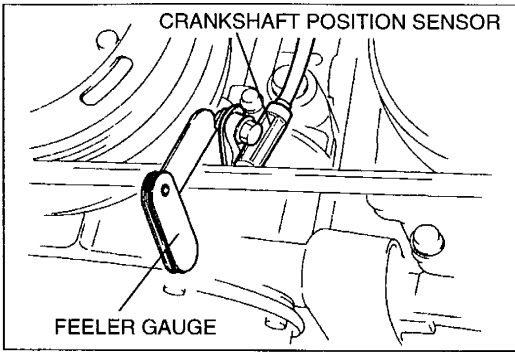

Air gap

1. Measure the air gap between the crankshaft pulley and the crankshaft position sensor by using a feeler gauge.

Specification: 0.5—1.5 mm { 0.020—0.059 in }

2. If not as specified, replace the crankshaft pulley or the crankshaft position sensor. (Refer to below.)

Replacement

1. Remove the undercover.
2. Remove the crankshaft position sensor.
3. Install in the reverse order of removal.

Tightening torque:

7.9—10.7 N·m { 80—110 kgf·cm , 70—95.4 in·lbf }

THROTTLE POSITION SENSOR

Inspection

1. Connect the SSTs (Engine Signal Monitor) to the PCM. (Refer to page F2-37.)
2. Verify that the throttle valve is at the closed throttle position.
3. Turn the ignition switch to ON.
4. Measure the voltage at PCM terminal 3F.

Specification:

Closed throttle position: 0.3—1.0 V

Wide open throttle: 2.8—4.5 V

(Verify that the voltage increase is directly proportioned to the throttle valve opening angle.)

5. If not as specified, adjust the throttle position sensor. (Refer to page F2-47.)

Using the NGS

1. Connect the SSTs (NGS) to the data link connector-2. (Refer to page F2-38.)
2. Verify that the throttle valve is at the closed throttle position.
3. Select the PID/DATA MONITOR AND RECORD function.
4. Select "TP V" on the NGS display. The NGS measures and shows the voltage.

Specification:

Closed throttle position: 0.3—1.0 V

Wide open throttle: 2.8—4.5 V

(Verify that the voltage increase is directly proportioned to the throttle valve opening angle.)

5. If not as specified, adjust the throttle position sensor. (Refer to page F2-47.)

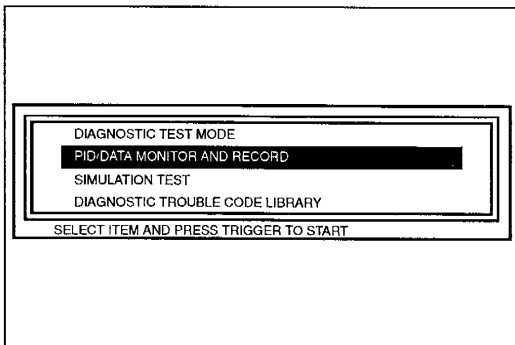

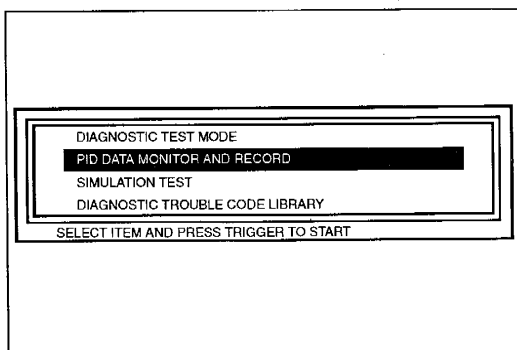
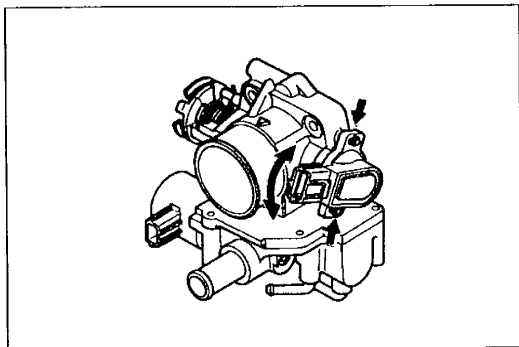
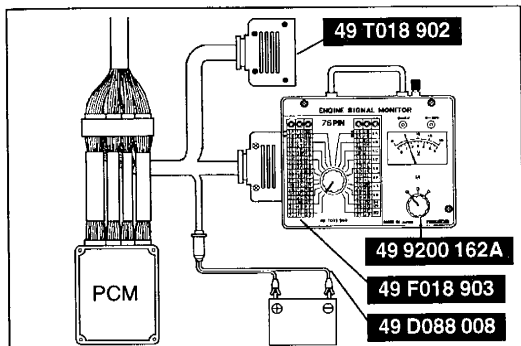
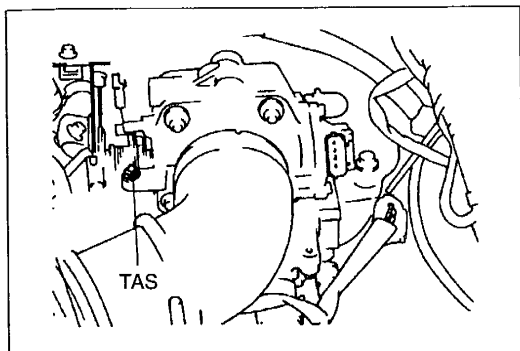

Adjustment

Caution

- The throttle position sensor is adjusted at the factory before shipment. Unnecessarily adjustment will negatively effect the engine performance.
- Adjusting the throttle position sensor by using the throttle adjusting screw (TAS) will negatively effect the engine performance.

1. Connect the **SSTs** (Engine Signal Monitor) to the PCM. (Refer to page F2-37.)
2. Verify that the throttle valve is at the closed throttle position.
3. Loosen the attaching screws.
4. Turn the ignition switch to ON.
5. Adjust the throttle position sensor so that the PCM terminal 3F voltage is as specified.

Specification:

Closed throttle position: 0.5—0.6 V

6. Tighten the attaching screws.

Tightening torque:

1.6—2.3 N·m { 16—24 kgf·cm , 14—20 in·lbf }

7. Fully open the throttle valve and verify that the voltage is with in the specification.

Specification

Wide open throttle: 2.8—4.5 V

(Verify that the voltage increase is directly proportioned to the throttle valve opening angle.)

8. If not as specified, inspect the throttle position sensor harness.
9. If the harness is OK, replace the throttle position sensor.

Using the NGS

1. Connect the **SSTs** (NGS) to the data link connector-2. (Refer to page F2-38.)
2. Select the PID/DATA MONITOR AND RECORD function.
3. Verify that the throttle valve is at the closed throttle position.
4. Loosen the attaching screws.
5. Select the "TP V" on the NGS display.
6. Adjust the throttle position sensor so that the throttle position signal voltage is as specified.

Specification

Closed throttle position: 0.5—0.6

- Tighten the attaching screws.

Tightening torque:

1.6—2.3 N·m { 16—24 kgf·cm , 14—20 in·lbf }

- Fully open the throttle valve and verify that the voltage is within the specification.

Specification

Wide open throttle: 2.8—4.5 V

(Verify that the voltage increase is directly proportional to the throttle valve opening angle.)

- If not as specified, inspect the throttle position sensor harness.
- If the harness is OK, replace the throttle position sensor.

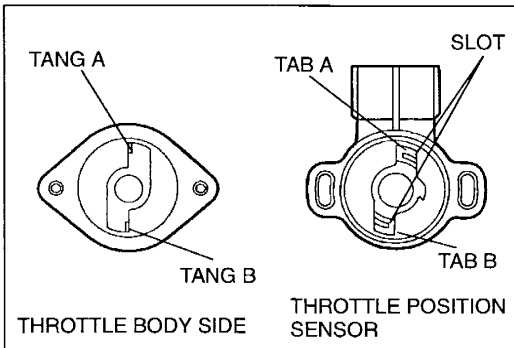

Replacement

- Disconnect the throttle position sensor connector.
- Remove the attaching screws.
- Remove the throttle position sensor.
- Verify that the throttle valve is fully closed.
- Open the throttle valve slightly and catch the tang of the throttle body on the throttle position sensor plastic tabs. Align tang A on throttle body with tab A on throttle position sensor. Note tangs on the throttle body mate with the tab on the throttle position sensor on the side of the tab without a slot.
- Position the throttle position sensor on the throttle body so that the mounting holes align.
- Install and hand tighten the attaching screws.
- Release the throttle.
- Adjust the throttle position sensor output voltage. (Refer to page F2-47.)

ENGINE COOLANT TEMPERATURE SENSOR

Inspection

- Remove the engine coolant temperature sensor. (Refer to page F2-35.)
- Place the sensor in water with a thermometer, and heat the water gradually.
- Measure the resistance of the sensor by using an ohmmeter.

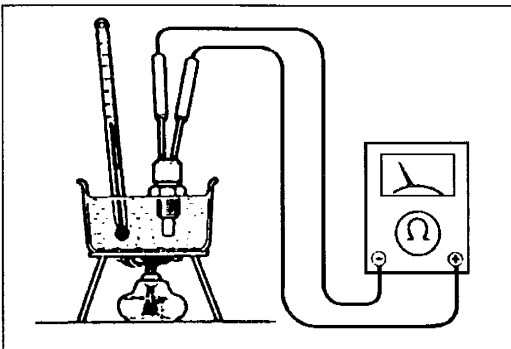

Specification

Water temperature (°C { °F })	Resistance (kΩ)
20 { 68 }	2.2—2.7
80 { 176 }	0.3—0.4

- If not as specified, replace the engine coolant temperature sensor.

HEATED OXYGEN SENSOR

Inspection

Sensor

- Warm up the engine to normal operating temperature.
- Connect the SSTs (Engine Signal Monitor) to the PCM. (Refer to page F2-37.)
- Measure the PCM terminal 3C and 3D voltages.

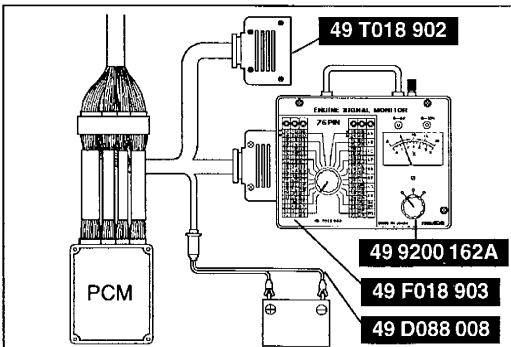

Specification

Engine condition	PCM terminal 3C	PCM terminal 3D
Idle	Below 1.0 V	Below 1.0 V
Deceleration	0—0.5 V	0—1.0 V
Acceleration	0.5—1.0 V	0—1.0 V

- If not as specified, inspect the following.
 - Harness and connector between heated oxygen sensor and PCM.
 - On-board diagnostic system (Refer to page F2-54.)
 - System inspection
 - Intake manifold vacuum (Refer to page F2-119.)
 - Fuel line pressure (Refer to page F2-120.)
- If all the systems are OK, replace the heated oxygen sensor. (Refer to page F2-35.)

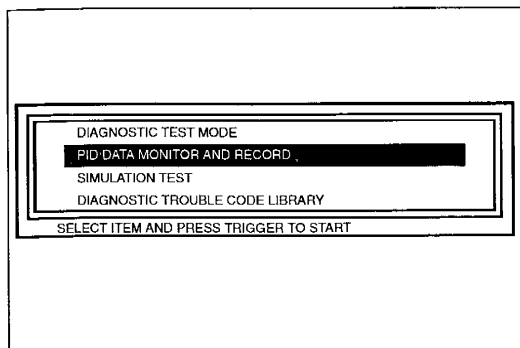

Using the NGS

- Connect the **SSTs** (NGS) to the data link connector-2. (Refer to page F2-38.)
- Select the PID/DATA MONITOR AND RECORD function.
- Select "FHO2S", "RHO2S" on the NGS display. The NGS measures and shows the voltage.

Specification

Engine condition	FHO2S voltage (V)	RHO2S voltage (V)
Idle	Below 1.0	Below 1.0
Deceleration	0—0.5	0—1.0
Acceleration	0.5—1.0	0—1.0

- If not as specified, inspect the following.
 - Harness and connector between heated oxygen sensor and PCM.
 - On-board diagnostic system (Refer to page F2-54.)
 - System inspection
 - Intake manifold vacuum (Refer to page F2-119.)
 - Fuel line pressure (Refer to page F2-120.)
- If all the systems are OK, replace the heated oxygen sensor. (Refer to page F2-35.)

Heater

- Disconnect the heated oxygen sensor connector.
- Measure the resistance between heated oxygen sensor terminals D and C by using an ohmmeter.

Specification: Approx. 13 Ω [20 °C { 68 °F }] (Front)
Approx. 6 Ω [20 °C { 68 °F }] (Rear)

- If not as specified, replace the heated oxygen sensor. (Refer to page F2-35.)

EGR VALVE POSITION SENSOR

Inspection

- Remove the air intake hose. (Refer to page F2-5.)
- Disconnect the EGR valve position sensor connector.
- Measure the resistance between terminals A and B by using an ohmmeter.

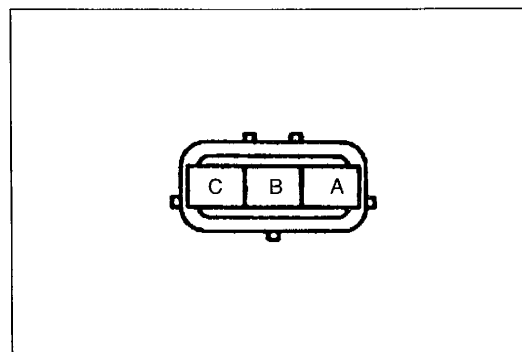
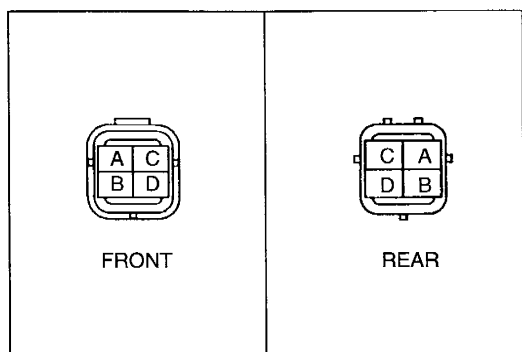

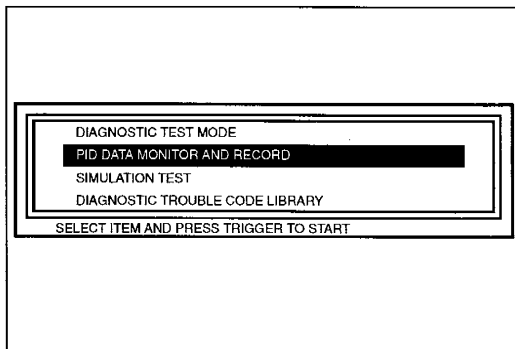
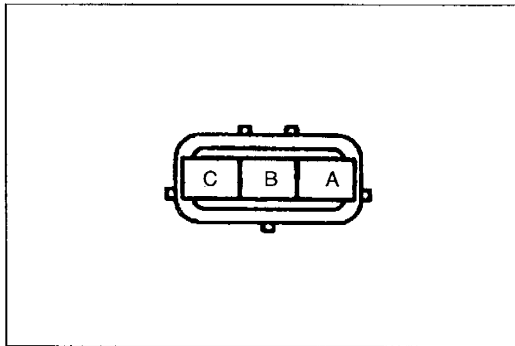
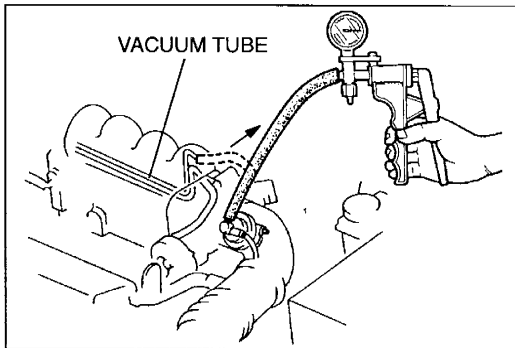
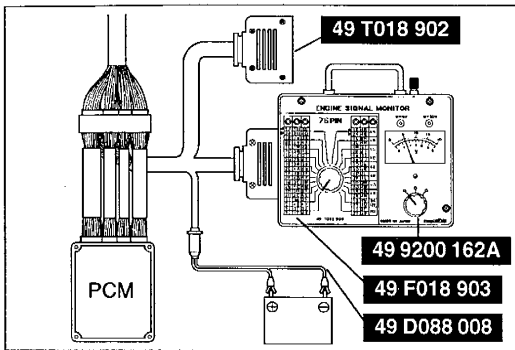

Specification: 2.7 kΩ

4. If not as specified, replace the EGR valve. (Refer to page F2-30.)
5. Connect the EGR valve position sensor connector.
6. Connect the air intake hose.
7. Connect the **SSTs** (Engine Signal Monitor) to the PCM.
8. Disconnect the vacuum hose from the vacuum tube and install a vacuum pump to the valve.
9. Turn the ignition switch to ON.
10. Measure the voltage at the PCM terminal 3J.

Specification

Vacuum	PCM terminal 3J voltage (V)
0 kPa { 0 mmHg , 0 inHg }	Approx. 0.8
Approx. 17 kPa { 128 mmHg , 5.04 inHg }	Approx. 4.9

11. If not as specified, inspect the harness and connector between the EGR valve position sensor and the PCM terminal.
12. If these harness and connector are OK, replace the EGR valve. (Refer to page F2-30.)

Using the NGS

1. Remove the air intake hose. (Refer to page F2-5.)
2. Disconnect the EGR valve position sensor connector.
3. Measure the resistance between terminals A and B of the connector by using an ohmmeter.

Specification: 2.7 kΩ

4. If not as specified, replace the EGR valve. (Refer to page F2-30.)
5. Connect the EGR valve position sensor connector.
6. Connect the air intake hose.
7. Connect the **SSTs** (NGS) to the data link connector-2. (Refer to page F2-38.)
8. Select the PID/DATA MONITOR AND RECORD function.
9. Disconnect the vacuum hose from the vacuum tube and install a vacuum pump to the valve.
10. Select the "EGRP V" on the NGS display. The NGS measures and shows the voltage.

Specification

Vacuum	EGR valve position signal voltage (V)
0 kPa { 0 mmHg , 0 inHg }	Approx. 0.8
Approx. 17 kPa { 128 mmHg , 5.04 inHg }	Approx. 4.9

11. If not as specified, inspect the harness and connector between the EGR valve position sensor and the PCM terminal.
12. If these harness and connector are OK, replace the EGR valve. (Refer to page F2-30.)

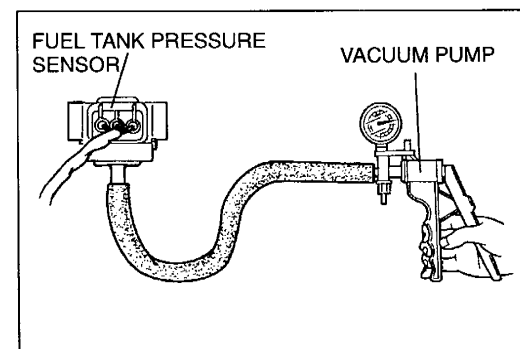
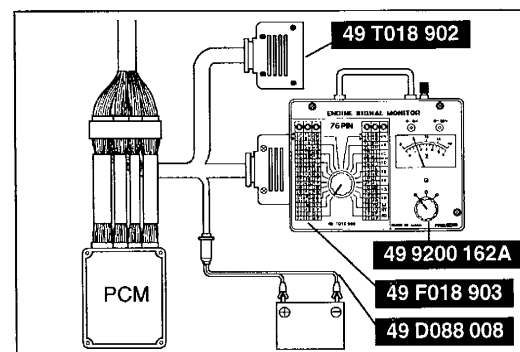
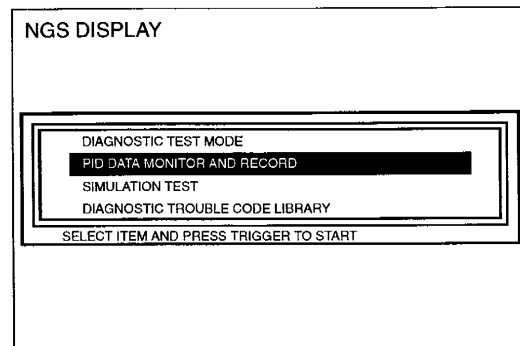
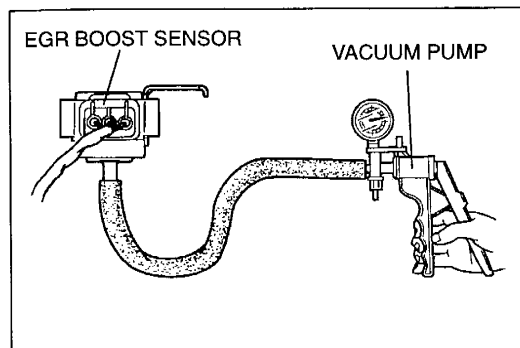
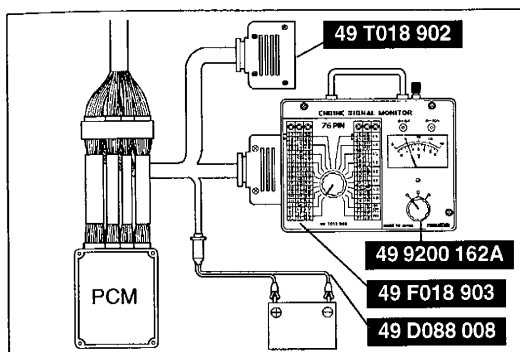

EGR BOOST SENSOR

Inspection

1. Connect the **SSTs** (Engine Signal Monitor) to the PCM. (Refer to page F2-37.)
2. Apply vacuum to the EGR boost sensor by using a vacuum pump. Measure the pressure at PCM terminal 3H.

Specification

Vacuum	PCM terminal 3H voltage (V)
86.3 kPa { 660 mmHg , 26.0 inHg }	Approx. 0.3
61.3 kPa { 460 mmHg , 18.1 inHg }	Approx. 1.6
6.3 kPa { 47.5 mmHg , 1.9 inHg }	Approx. 4.4

3. If not as specified, replace the EGR boost sensor. (Refer to page F2-35.)

Using the NGS

1. Connect the **SSTs** (NGS) to the data link connector-2. (Refer to page F2-38.)
2. Select the PID/DATA MONITOR AND RECORD function.
3. Apply vacuum to the EGR boost sensor by using a vacuum pump.
4. Select "BARO V" on the NGS display. The NGS measures and shows the voltage.

Specification

Vacuum	Barometric pressure signal voltage (V)
86.3 kPa { 660 mmHg , 26.0 inHg }	Approx. 0.3
61.3 kPa { 460 mmHg , 18.1 inHg }	Approx. 1.6
6.3 kPa { 47.5 mmHg , 1.9 inHg }	Approx. 4.4

5. If not as specified, replace the EGR boost sensor. (Refer to page F2-35.)

FUEL TANK PRESSURE SENSOR

Inspection

1. Connect the **SSTs** (Engine Signal Monitor) to the PCM. (Refer to page F2-37.)
2. Apply vacuum to the fuel tank pressure sensor by using a vacuum pump. Measure the pressure at PCM terminal 3A.

Specification

Vacuum	PCM terminal 3A voltage (V)
0 kPa { 0 mmHg , 0 inHg }	Approx. 2.5
6.7 kPa { 50 mmHg , 2.0 inHg }	Approx. 0.5

3. If not as specified, replace the fuel tank pressure sensor. (Refer to page F2-14.)

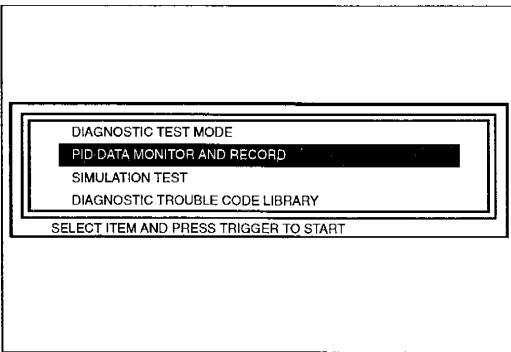

Using the NGS

1. Connect the **SSTs** (NGS) to the data link connector-2. (Refer to page F2-38.)
2. Select the **PID/DATA MONITOR AND RECORD** function.
3. Apply vacuum to the fuel tank pressure sensor by using a vacuum pump.
4. Select "FTP V" on the NGS display. The NGS measures and shows the voltage.

Specification

Vacuum	Fuel tank pressure signal voltage (V)
0 kPa { 0 mmHg , 0 inHg }	Approx. 2.5
6.7 kPa { 50 mmHg , 2.0 inHg }	Approx. 0.5

5. If not as specified, replace the fuel tank pressure sensor. (Refer to page F2-14.)

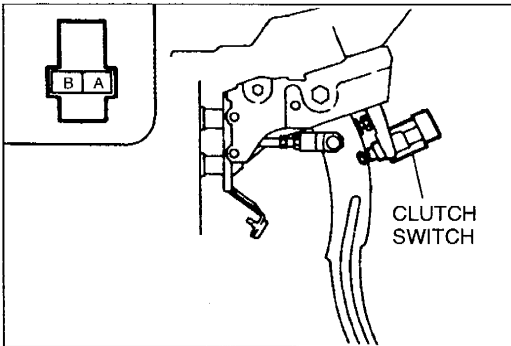

CLUTCH SWITCH

Inspection

1. Disconnect the clutch switch connector.
2. Check for continuity between terminals of the clutch switch by using an ohmmeter.

○—○: Continuity

Condition \ Terminal	A	B
Clutch pedal not depressed		
Clutch pedal depressed	○—○	○—○

3. If not as specified, replace the clutch switch.

Replacement

Install the clutch switch as shown in the figure.

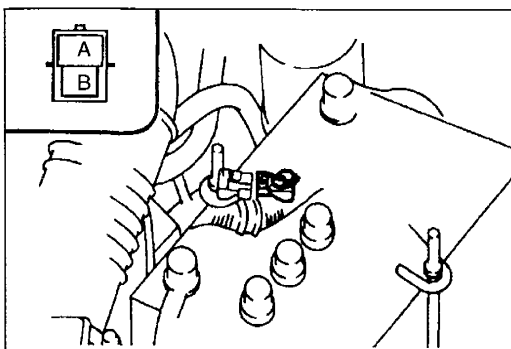
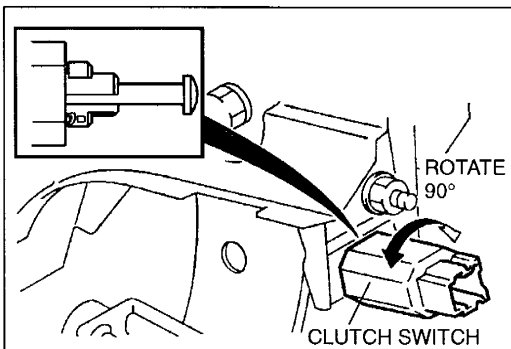

NEUTRAL SWITCH

Inspection

1. Disconnect the neutral switch connector.
2. Check for continuity between terminals of the neutral switch by using an ohmmeter.

○—○: Continuity

Condition \ Terminal	A	B
Neutral position	○—○	○—○
Others		

3. If not as specified, replace the neutral switch. (Refer to page F2-35.)

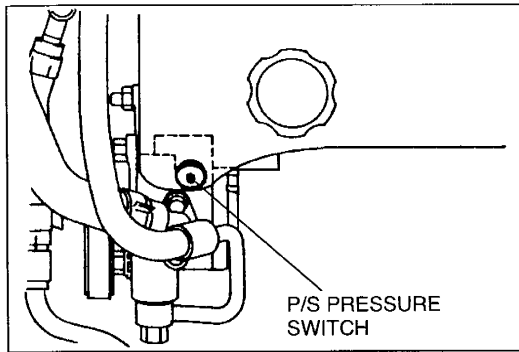

POWER STEERING PRESSURE SWITCH

Inspection

1. Disconnect the power steering pressure switch connector.
2. Start the engine.
3. Check for the continuity between power steering pressure switch terminal and a ground by using an ohmmeter.

○—○: Continuity

Condition \ Terminal	A	Ground
Steering wheel not turned		
Steering wheel being turned	○—○	○—○

4. If not as specified, replace the power steering pressure switch. (Refer to page F2-35.)

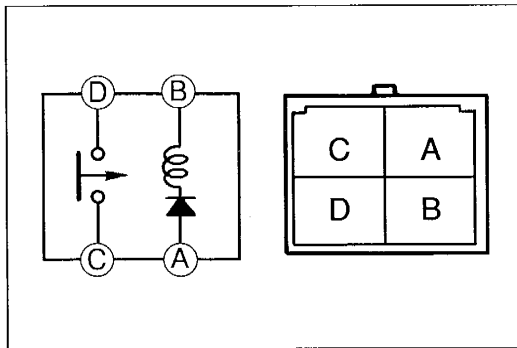

MAIN RELAY

Inspection

1. Remove the main relay. (Refer to page F2-35.)
2. Check the continuity between the relay terminals by using an ohmmeter.



○—○: Continuity B+: Battery positive voltage

Step \ Terminal	A	B	C	D
1	○—○	○—○		
2	Ground	B+	○—○	○—○

3. If not as specified, replace the main relay.

ON-BOARD DIAGNOSTIC SYSTEM

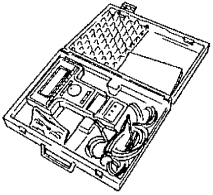
PREPARATION SST

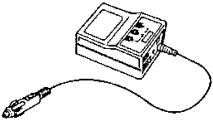
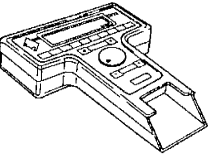
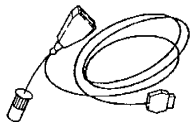
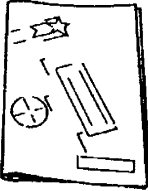
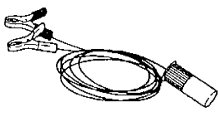
<p>49 T088 0A0 NGS set</p> 	<p>For diagnosis of PCM and input/output systems</p>	<p>49 T088 010B Program Card</p> 	<p>For diagnosis of PCM and input/output systems</p>
<p>49 T088 002 Vehicle Interface Module (Part of 49 T088 0A0)</p> 	<p>For diagnosis of PCM and input/output systems</p>	<p>49 T088 001 Control Unit (Part of 49 T088 0A0)</p> 	<p>For diagnosis of PCM and input/output systems</p>
<p>49 T088 004 NGS OBDII Adapter (Part of 49 T088 0A0)</p> 	<p>For diagnosis of PCM and input/output systems</p>	<p>49 T088 008A Instruction Manual</p> 	<p>For diagnosis of PCM and input/output systems</p>
<p>49 T088 006 Battery Hookup Adapter (Part of 49 T088 0A0)</p> 	<p>For diagnosis of PCM and input/output systems</p>	<p>—</p>	<p>—</p>

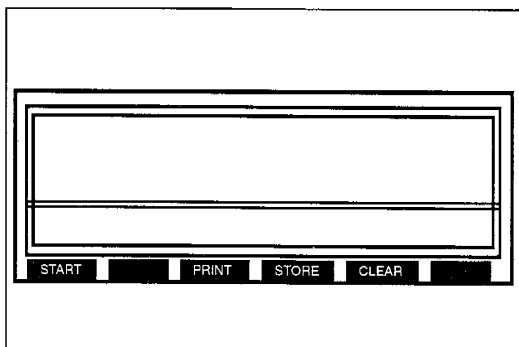
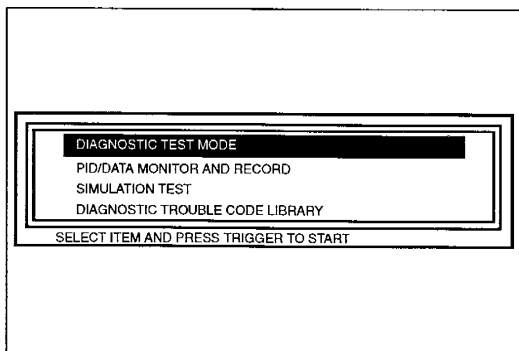

DIAGNOSTIC TROUBLE CODE NUMBER Inspection

1. Connect the SSTs (NGS) to the data link connector-2. (Refer to page F2-38.)
2. Refer to the manufacturer-provided instruction manual for the NGS operation.
3. Select "DIAGNOSTIC TEST MODE" function and press trigger.
4. When "NO CODES RECEIVED/SYSTEM PASSED" is displayed, all systems monitored are judged OK.
5. When any of the diagnostic trouble codes is displayed, carry out troubleshooting according to the code. (Refer to page F2-55.)
6. If "LINK MONITOR ERROR" is displayed, check connection of the NGS.
7. After all problems have been repaired, carry out "After Repair Procedure." (Refer to below.)



After Repair Procedure

1. After repairs, connect the NGS to the data link connector-2.
2. Select "CLEAR" function and erase diagnostic trouble codes from the PCM memory.
3. Perform diagnostic trouble code inspection again and verify that no diagnostic trouble codes are displayed.

Diagnostic Trouble Code Numbers





DTC	Display on the NGS	Condition	Page
P0100	MAF/VAF—CIRCUIT MALFUNCTION	Mass air flow circuit malfunction	F2-57
P0110	IAT—CIRCUIT MALFUNCTION	Intake air temperature circuit malfunction	F2-58
P0115	ECT—CIRCUIT MALFUNCTION	Engine coolant temperature circuit malfunction	F2-59
P0120	TP—CIRCUIT MALFUNCTION	Throttle position circuit malfunction	F2-60
P0125	EXCESSIVE TIME TO ENTER CLOSED LOOP	Excessive time to enter closed loop fuel control	F2-61
P0130	O2S 11—CIRCUIT MALFUNCTION	O ₂ sensor circuit malfunction	F2-61
P0134	O2S 11—CIRCUIT NO ACTIVITY DETECTED	O ₂ sensor circuit no activity detected	F2-62
P0135	O2S 11—HEATER CIRCUIT MALFUNCTION	O ₂ sensor heater circuit malfunction	F2-63
P0140	O2S 12—CIRCUIT NO ACTIVITY DETECTED	O ₂ sensor circuit no activity detected	F2-64
P0170	BANK 1—FUEL TRIM MALFUNCTION	Fuel trim malfunction	F2-65
P0300	RANDOM MISFIRE DETECTED	Random misfire detected	F2-66
P0301	CYLINDER 1 MISFIRE DETECTED	Cylinder 1 misfire detected	F2-67
P0302	CYLINDER 2 MISFIRE DETECTED	Cylinder 2 misfire detected	F2-68
P0303	CYLINDER 3 MISFIRE DETECTED	Cylinder 3 misfire detected	F2-69
P0304	CYLINDER 4 MISFIRE DETECTED	Cylinder 4 misfire detected	F2-70
P0335	CRANKSHAFT POS SENSOR—CKT MALFUNCTION	Crankshaft position sensor circuit malfunction	F2-71
P0340	CAMSHAFT POS SENSOR—CKT MALFUNCTION	Camshaft position sensor circuit malfunction	F2-72
P0400	EGR—FLOW MALFUNCTION	Exhaust gas recirculation flow malfunction	F2-73
P0420	BANK 1 CAT EFFICIENCY BELOW LIMIT	Catalyst system efficiency below threshold	F2-73
P0440	EVAP SYSTEM—MALFUNCTION	Evaporative emission control system malfunction	F2-74

DTC	Display on the NGS	Condition	Page
P0443	EVAP SYSTEM—PURGE CTRL VALVE CKT MALF	Evaporative emission control system purge control valve circuit malfunction	F2-75
P0450	EVAP SYSTEM—PRESSURE SEN MALFUNCTION	Evaporative emission control system pressure sensor malfunction	F2-76
P0500	VEHICLE SPEED SENSOR—MALFUNCTION	Vehicle speed sensor malfunction	F2-77
P0505	IDLE CONTROL SYSTEM—MALFUNCTION	Idle control system malfunction	F2-78
P0703	TORQUE CONV/BRAKE SW—MALFUNCTION	Brake switch input malfunction	F2-79
P1000	MORE DRIVING NEEDED TO COMPLETE TEST	Check of all OBD-II system is not complete since last memory clear	F2-79
P1170	HO2S 11—INVERSION	Heated oxygen sensor (Front) (Inversion)	F2-80
P1195	EGRBS—OPEN OR SHORT	EGR boost sensor open or short	F2-81
P1250	PRC—OPEN OR SHORT	PRC solenoid valve open or short (ATX only)	F2-82
P1402	EGRS—OPEN OR SHORT	EGR valve position sensor open or short	F2-83
P1449	CDCV—OPEN OR SHORT	Canister drain cut valve open or short	F2-84
P1455	FUEL TANK LEVEL SENSOR—OPEN OR SHORT	Fuel gauge sender unit circuit open or short	F2-85
P1485	EGR (VACUUM)—OPEN OR SHORT	EGR solenoid valve (vacuum) open or short	F2-86
P1486	EGR (VENT)—OPEN OR SHORT	EGR solenoid valve (vent) open or short	F2-87
P1487	EGRCHK SOL.—OPEN OR SHORT	EGR boost sensor solenoid valve open or short	F2-88
P1523	VICS—OPEN OR SHORT	VICS solenoid valve open or short	F2-89
P1608	PCME (CPU)—MALFUNCTION	PCM (CPU) malfunction	F2-90
P1794	BAT—BAT OR CIRCUIT FAIL	Battery or circuit malfunction	F2-90
P1797	PNS—OPEN OR SHORT	P or N range or neutral/clutch switch signal open or short	F2-91

Diagnostic trouble code No. P0100		MAF/VAF—CIRCUIT MALFUNCTION	
Symptom		Input voltage from mass air flow sensor is below 0.2 V or above 4.9 V when ignition switch is turned on	
Possible cause		<ul style="list-style-type: none"> • Mass air flow sensor malfunction • Open or short circuit in wiring from main relay terminal D to mass air flow sensor terminal A • Open or short circuit in wiring from PCM terminal 3B to mass air flow sensor terminal B • Open circuit in wiring from PCM terminal 4A to mass air flow sensor terminal E 	
STEP	INSPECTION		ACTION
1	Does mass air flow sensor connector or PCM connector have poor connection?	Yes	Repair or replace connector
		No	Go to next step
2	Is PCM terminal 3B voltage OK?  page F2-39	Yes	Go to step 6
		No	Go to next step
3	Disconnect mass air flow sensor connector. Turn ignition switch to ON. Is there battery positive voltage at harness side connector terminal A?	Yes	Go to next step
		No	Check for open or short circuit in wiring harness. (Main relay terminal D — Mass air flow sensor terminal A)
4	Is there continuity between harness side connector terminal E and PCM terminal 4A?	Yes	Go to next step
		No	Repair or replace wiring harness
5	Is there continuity between harness side connector terminal B and PCM terminal 3B?	Yes	Replace mass air flow sensor  page F2-5
		No	Repair or replace wiring harness
6	Erase diagnostic trouble code from memory. Is same code No. present after rechecking?	Yes	Replace PCM  page F2-36
		No	Intermittent poor connection of harness or connector (Repair connector and/or harness)







HARNESS SIDE CONNECTOR
(VIEW FROM BEHIND OF CONNECTOR)

Diagnostic trouble code No. P0110		IAT—CIRCUIT MALFUNCTION	
Symptom		Input from intake air temperature sensor is below 0.1 V or above 4.8 V when ignition switch is turned on	
Possible cause		<ul style="list-style-type: none"> • Intake air temperature sensor malfunction • Open or short circuit in wiring from mass air flow sensor terminal C to PCM terminal 3K • Open or short circuit in wiring from mass air flow sensor terminal D to PCM terminal 3O 	
STEP	INSPECTION	ACTION	
1	Does mass air flow sensor connector or PCM connector have poor connection?	Yes	Repair or replace connector
		No	Go to next step
2	Is PCM terminal 3K voltage OK?  page F2-39	Yes	Go to step 6
		No	Go to next step
3	Disconnect mass air flow sensor connector. Turn ignition switch to ON. Is there 5 V at harness side connector terminal C?	Yes	Go to next step
		No	Check for open or short circuit in wiring harness. (PCM terminal 3K — Mass air flow sensor terminal C)
4	Is there continuity between harness side connector terminal D and PCM terminal 3O?	Yes	Go to next step
		No	Repair or replace wiring harness
5	Is intake air temperature sensor OK?  page F2-45	Yes	Go to next step
		No	Replace Mass air flow sensor  page F2-5
6	Erase diagnostic trouble code from memory. Is same code No. present after rechecking?	Yes	Replace PCM  page F2-36
		No	Intermittent poor connection of harness of connector (Repair connector and/or harness)



HARNESS SIDE CONNECTOR
(VIEW FROM BEHIND OF CONNECTOR)

Diagnostic trouble code No. P0115		ECT—CIRCUIT MALFUNCTION	
Symptom		Input voltage from engine coolant temperature sensor is below 0.2 V or above 4.9 V when ignition switch is turned on	
Possible cause		<ul style="list-style-type: none"> • Engine coolant temperature sensor malfunction • Open or short circuit in wiring from engine coolant temperature sensor terminal A to PCM terminal 3G • Open or short circuit in wiring from engine coolant temperature sensor terminal B to PCM terminal 3O 	
STEP	INSPECTION	ACTION	
1	Does engine coolant temperature sensor or PCM connector have poor connection?	Yes	Repair or replace connector
		No	Go to next step
2	Is PCM terminal 3G voltage OK? 👉 page F2-39	Yes	Go to step 6
		No	Go to next step
3	Disconnect engine coolant temperature sensor connector. Turn ignition switch ON. Is there 5 V at harness side connector terminal A?	Yes	Go to next step
		No	Check for open or short circuit in wiring harness. (PCM terminal 3G — Engine coolant temperature sensor terminal A)
4	Is there continuity between harness side connector terminal B and PCM terminal 3O?	Yes	Go to next step
		No	Repair or replace wiring harness
5	Is engine coolant temperature sensor OK? 👉 page F2-48	Yes	Go to next step
		No	Replace engine coolant temperature sensor 👉 page F2-35
6	Erase diagnostic trouble code from memory. Is same code No. present after rechecking?	Yes	Replace PCM 👉 page F2-36
		No	Intermittent poor connection of harness or connector (Repair connector and/or harness)
 <p>HARNESS SIDE CONNECTOR (VIEW FROM BEHIND OF CONNECTOR)</p>			

Diagnostic trouble code No. P0120		TP—CIRCUIT MALFUNCTION	
Symptom		Input voltage from throttle position sensor is below 0.1 V or above 4.7 V when ignition switch is turned on	
Possible cause		<ul style="list-style-type: none"> • Throttle position sensor malfunction • Open or short circuit in wiring from throttle position sensor terminal A to PCM terminal 3O • Open or short circuit in wiring from throttle position sensor terminal C to PCM terminal 3F • Open or short circuit in wiring from throttle position sensor terminal D to PCM terminal 3I 	
STEP	INSPECTION		ACTION
1	Does throttle position sensor connector or PCM connector have poor connection?	Yes	Repair or replace connector
		No	Go to next step
2	Is PCM terminal 3F voltage OK?  page F2-39	Yes	Go to next step
		No	Go to step 4
3	Is voltage increase linear according to throttle valve opening angle?	Yes	Go to step 7
		No	Replace throttle position sensor  page F2-46
4	Disconnect throttle position sensor connector. Turn ignition switch to ON. Is there 5 V at harness side connector terminal D?	Yes	Go to next step
		No	Check for open or short circuit in wiring harness. (PCM terminal 3I — Throttle position sensor terminal D)
5	Is there continuity between harness side connector terminal A and PCM terminal 3O?	Yes	Go to next step
		No	Repair or replace wiring harness
6	Is there continuity between harness side connector terminal D and PCM terminal 3I?	Yes	Replace throttle position sensor  page F2-47
		No	Repair or replace wiring harness
7	Erase diagnostic trouble code from memory. Is same code No. present after rechecking?	Yes	Replace PCM  page F2-36
		No	Intermittent poor connection of harness or connector (Repair connector and/or harness)



HARNESS SIDE CONNECTOR
(VIEW FROM BEHIND OF CONNECTOR)

Diagnostic trouble code No. P0125		EXCESSIVE TIME TO ENTER CLOSED LOOP	
Symptom		Engine coolant temperature sensor signal does not rise normally because of engine coolant system malfunction	
Possible cause		<ul style="list-style-type: none"> • Engine coolant temperature sensor malfunction • Thermostat malfunction • Cooling system malfunction • Water pump malfunction • Engine coolant passage clogged or leaks • Engine coolant level and protection incorrect 	
STEP	INSPECTION		ACTION
1	Is electrical fan control system OK? ☞ page F2-132	Yes	Go to next step
		No	Repair or replace engine coolant fan system
2	Is engine coolant temperature sensor resistance OK? ☞ page F2-48	Yes	Go to next step
		No	Replace engine coolant temperature sensor
3	Is cooling system OK? ☞ section E	Yes	Go to next step
		No	Repair or replace
4	Erase diagnostic trouble code from memory. Is same code No. present after *rechecking?	Yes	Replace PCM ☞ page F2-36
		No	Temporary system malfunction

* During normal driving

Diagnostic trouble code No. P0130		O2S 11—CIRCUIT MALFUNCTION	
Symptom		<ul style="list-style-type: none"> • Heated oxygen sensor (Front) deterioration • Leakage in exhaust system 	
STEP	INSPECTION		ACTION
1	Is heated oxygen sensor (Front) OK? ☞ page F2-48	Yes	Go to next step
		No	Repair or replace heated oxygen sensor (Front) ☞ page F2-35
2	Erase diagnostic trouble code from memory. Is same code No. present after *rechecking?	Yes	Replace PCM ☞ page F2-36
		No	Intermittent poor connection of harness or connector (Repair connector and/or harness)

* During normal driving

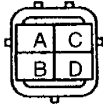
Diagnostic trouble code No. P0134		O2S 11—CIRCUIT NO ACTIVITY DETECTED	
Symptom		When heated oxygen sensor (Front) signal does not exceed 0.5 V after engine is started, or stays below 0.5 V for two minutes after engine has reached normal operating temperature and running at 1,500 rpm or over	
Possible cause		<ul style="list-style-type: none"> • Low fuel • Heated oxygen sensor (Front) malfunction • Open or short circuit in wiring from heated oxygen sensor (Front) terminal A to PCM terminal 3C • Intake-air system, fuel system, ignition system malfunction 	
STEP	INSPECTION		ACTION
1	Does heated oxygen sensor (Front) connector or PCM connector have poor connection?	Yes	Repair or replace connector
		No	Go to next step
2	Is PCM terminal 3D voltage OK? 🔧 page F2-39	Yes	Go to step 5
		No	Go to next step
3	Disconnect heated oxygen sensor (Front) connector. Is there continuity between harness side connector terminal A and PCM terminal 3C?	Yes	Go to next step
		No	Repair or replace wiring harness
4	Are following units OK? Fuel injector 🔧 page F2-22 Pressure regulator 🔧 page F2-23 Mass air flow sensor 🔧 page F2-44 Engine coolant temperature sensor 🔧 page F2-48 Spark plug 🔧 section G Air suction (Air/Fuel ratio rich or lean)	Yes	Replace heated oxygen sensor (Front) and go to next step 🔧 page F2-35
		No	Repair or replace
5	Erase diagnostic trouble code from memory. Is same code No. present after rechecking?	Yes	Replace PCM 🔧 page F2-36
		No	Intermittent poor connection of harness or connector (Repair connector and/or harness)
 <p>HARNESS SIDE CONNECTOR (VIEW FROM BEHIND OF CONNECTOR)</p>			





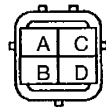



Diagnostic trouble code No. P0135	O2S 11—HEATER CIRCUIT MALFUNCTION
Symptom	Open or short circuit is observed in heated oxygen sensor heater (Front) system when ignition switch is turned on
Possible cause	<ul style="list-style-type: none"> • Heated oxygen sensor heater (Front) malfunction • Open or short circuit in wiring from heated oxygen sensor (Front) terminal C to ignition switch • Open or short circuit in wiring from heated oxygen sensor (Front) terminal D to PCM terminal 3M

STEP	INSPECTION	ACTION	
1	Does heated oxygen sensor (Front) connector or PCM connector have poor connection?	Yes	Repair or replace connector
		No	Go to next step
2	Is PCM terminal 3M voltage OK? ☞ page F2-39	Yes	Go to step 6
		No	Go to next step
3	Disconnect heated oxygen sensor (Front) harness side connector and turn ignition switch to ON. Is there battery positive voltage at harness side connector terminal C?	Yes	Go to next step
		No	Check for open or short circuit in wiring harness. [Ignition switch — Heated oxygen sensor (Front) terminal C]
4	Is there continuity between harness side connector terminal D and PCM terminal 3M?	Yes	Go to next step
		No	Repair or replace wiring harness
5	Is there continuity between harness side connector terminals A and C?	Yes	Go to next step
		No	Replace heated oxygen sensor (Front) ☞ page F2-35
6	Erase diagnostic trouble code from memory. Is same code No. present after rechecking?	Yes	Replace PCM ☞ page F2-36
		No	Intermittent poor connection of harness or connector (Repair connector and/or harness)



HARNESS SIDE CONNECTOR
(VIEW FROM BEHIND OF CONNECTOR)

Diagnostic trouble code No. P0140	O2S 12—CIRCUIT NO ACTIVITY DETECTED
Symptom	When heated oxygen sensor (Rear) signal does not exceed 0.5 V after engine is started, or stays below 0.5 V for two minutes after engine has reached normal operating temperature and running at 1,500 rpm or over
Possible cause	<ul style="list-style-type: none"> • Low fuel • Heated oxygen sensor (Rear) malfunction • Open or short circuit in wiring from (Rear) heated oxygen sensor (Rear) terminal A to PCM terminal 3D • Open circuit in wiring from heated oxygen sensor (Rear) terminal B to PCM terminal 3O. • Intake-air system, fuel system or ignition system malfunction







STEP	INSPECTION	ACTION	
1	Does heated oxygen sensor (Rear) connector or PCM connector have poor connection?	Yes	Repair or replace connector
		No	Go to next step
2	Is PCM terminal 3D voltage OK?  page F2-39	Yes	Go to step 6
		No	Go to next step
3	Disconnect heated oxygen sensor (Rear) connector. Is there continuity between harness side connector terminal B and PCM terminal 3O?	Yes	Go to next step
		No	Repair or replace wiring harness
4	Is there continuity between harness side connector terminal A and PCM terminal 3D?	Yes	Go to next step
		No	Repair or replace wiring harness
5	Are following units OK?  page F2-22 Fuel injector  page F2-23 Pressure regulator  page F2-44 Mass air flow sensor  page F2-48 Engine coolant temperature sensor  section G Spark plug Air suction (Air/Fuel ratio rich)	Yes	Replace heated oxygen sensor (Rear)  page F2-35
		No	Repair or replace
6	Erase diagnostic trouble code from memory. Is same code No. present after rechecking?	Yes	Replace PCM  page F2-36
		No	Intermittent poor connection of harness or connector (Repair connector and/or harness)



HARNESS SIDE CONNECTOR
(VIEW FROM BEHIND OF CONNECTOR)

Diagnostic trouble code No. P0170		BANK 1—FUEL TRIM MALFUNCTION	
Symptom		Air/fuel ratio stays rich or lean longer than specified period because of system malfunction	
Possible cause		<ul style="list-style-type: none"> • Low fuel • Pressure regulator malfunction • Fuel injector malfunction • Fuel pump malfunction • Engine coolant temperature sensor malfunction • Mass air flow sensor malfunction • Heated oxygen sensor malfunction • Purge solenoid valve malfunction • Leakage in intake-air system • PCM malfunction • Open or short circuit in wiring between PCM terminals 4U, 4V, 4W, 4X to fuel injector • Intake air temperature sensor malfunction • EGR boost sensor malfunction • PCV valve malfunction 	
STEP	INSPECTION	ACTION	
1	Is there air leakage in intake-air system components? ☞ page F2-119	Yes	Repair or replace intake-air system
		No	Go to next step
2	Is fuel line pressure OK? ☞ page F2-121	Yes	Go to step 5
		No	Go to next step
3	Is fuel pump maximum pressure OK? ☞ page F2-21	Yes	Go to next step
		No	Repair or replace fuel pump ☞ page F2-21
4	Is pressure regulator OK? ☞ page F2-23	Yes	Go to next step
		No	Replace pressure regulator ☞ page F2-23
5	Is fuel injector OK? ☞ page F2-22	Yes	Go to next step
		No	Replace fuel injector ☞ page F2-22
6	Is engine coolant temperature sensor OK? ☞ page F2-48	Yes	Go to next step
		No	Replace engine coolant temperature sensor ☞ page F2-35
7	Is mass air flow sensor OK? ☞ page F2-44	Yes	Go to next step
		No	Replace mass air flow sensor ☞ page F2-5
8	Is throttle position sensor OK? ☞ page F2-46	Yes	Go to next step
		No	Adjust throttle position sensor ☞ page F2-47
9	Is intake air temperature sensor OK? ☞ page F2-45	Yes	Go to next step
		No	Replace mass air flow sensor ☞ page F2-5
10	Is EGR boost sensor OK? ☞ page F2-50	Yes	Go to next step
		No	Replace EGR boost sensor ☞ page F2-35
11	Is purge solenoid valve OK? ☞ page F2-33	Yes	Go to next step
		No	Replace purge solenoid valve ☞ page F2-30
12	Is PCV valve OK? ☞ page F2-33	Yes	Go to next step
		No	Replace PCV valve
13	Erase diagnostic trouble code from memory. Is same code No. present after *rechecking?	Yes	Replace PCM ☞ page F2-36
		No	Temporary system malfunction









* During Idling

Diagnostic trouble code No. P0300		RANDOM MISFIRE DETECTED	
Symptom		PCM input signal from crankshaft position sensor signal is irregular	
Possible cause		<ul style="list-style-type: none"> • Ignition system malfunction • Low fuel • Low battery positive voltage • Fuel system malfunction • Insufficient compression • Crankshaft position sensor air gap incorrect • Exhaust gas recirculation system malfunction 	
STEP	INSPECTION	ACTION	
1	Is ignition system OK?  section G	Yes	Go to next step
		No	Repair or replace as necessary
2	Is crankshaft position sensor air gap correct?  page F2-46	Yes	Go to next step
		No	Repair or replace crankshaft position sensor  page F2-46
3	Is fuel system OK?  page F2-11	Yes	Go to next step
		No	Repair or replace as necessary
4	Is exhaust gas recirculation system OK?  page F2-130	Yes	Go to next step
		No	Repair or replace as necessary
5	Is compression at all cylinders normal?  section B2	Yes	Go to next step
		No	Repair or replace as necessary
6	Erase diagnostic trouble code from memory. Is same code No. present after *rechecking?	Yes	Replace PCM  page F2-36
		No	Temporary system malfunction

* During normal driving

Diagnostic trouble code No. P0301		CYLINDER 1 MISFIRE DETECTED	
Symptom		PCM input signal from crankshaft position sensor signal for cylinder No.1 is irregular	
Possible cause		<ul style="list-style-type: none"> • Ignition system of cylinder No.1 malfunction • Low fuel • Low battery positive voltage • Fuel system malfunction • Insufficient compression in cylinder No.1 • Crankshaft position sensor air gap incorrect • Exhaust gas recirculation system malfunction 	
STEP	INSPECTION	ACTION	
1	Is ignition system of cylinder No.1 OK? 🔧 section G	Yes	Go to next step
		No	Repair or replace as necessary
2	Is crankshaft position sensor air gap OK? 🔧 page F2-46	Yes	Go to next step
		No	Repair or replace crankshaft position sensor 🔧 page F2-46
3	Is fuel injector at cylinder No.1 OK? 🔧 page F2-126	Yes	Go to next step
		No	Repair or replace fuel injector at cylinder No.1 🔧 page F2-22
4	Is fuel system OK? 🔧 page F2-11	Yes	Go to next step
		No	Repair or replace as necessary
5	Is exhaust gas recirculation system OK? 🔧 page F2-130	Yes	Go to next step
		No	Repair or replace as necessary
6	Is compression at cylinder No.1 normal? 🔧 section B2	Yes	Go to next step
		No	Repair or replace as necessary
7	Erase diagnostic trouble code from memory. Is same code No. present after *rechecking?	Yes	Replace PCM 🔧 page F2-36
		No	Temporary system malfunction

* During normal driving

Diagnostic trouble code No. P0302		CYLINDER 2 MISFIRE DETECTED	
Symptom		PCM input signal from crankshaft position sensor signal for cylinder No.2 is irregular	
Possible cause		<ul style="list-style-type: none"> • Ignition system of cylinder No.2 malfunction • Low fuel • Low battery positive voltage • Fuel system malfunction • Insufficient compression in cylinder No.2 • Crankshaft position sensor air gap incorrect • Exhaust gas recirculation system malfunction 	
STEP	INSPECTION	ACTION	
1	Is ignition system of cylinder No.2 OK?  section G	Yes	Go to next step
		No	Repair or replace as necessary
2	Is crankshaft position sensor air gap OK?  page F2-46	Yes	Go to next step
		No	Repair or replace crankshaft position sensor  page F2-46
3	Is fuel injector at cylinder No.2 OK?  page F2-126	Yes	Go to next step
		No	Repair or replace fuel injector at cylinder No.2  page F2-22
4	Is fuel system OK?  page F2-11	Yes	Go to next step
		No	Repair or replace as necessary
5	Is exhaust gas recirculation system OK?  page F2-130	Yes	Go to next step
		No	Repair or replace as necessary
6	Is compression at cylinder No.2 normal?  section B2	Yes	Go to next step
		No	Repair or replace as necessary
7	Erase diagnostic trouble code from memory. Is same code No. present after *rechecking?	Yes	Replace PCM  page F2-36
		No	Temporary system malfunction

* During normal driving



Diagnostic trouble code No. P0303	CYLINDER 3 MISFIRE DETECTED		
Symptom	PCM input signal from crankshaft position sensor signal for cylinder No.3 is irregular		
Possible cause	<ul style="list-style-type: none"> • Ignition system of cylinder No.3 malfunction • Low fuel • Low battery positive voltage • Fuel system malfunction • Insufficient compression in cylinder No.3 • Crankshaft position sensor air gap incorrect • Exhaust gas recirculation system malfunction 		
STEP	INSPECTION		ACTION
1	Is ignition system of cylinder No.3 OK? ☞ section G	Yes No	Go to next step Repair or replace as necessary
2	Is crankshaft position sensor air gap OK? ☞ page F2-46	Yes No	Go to next step Repair or replace crankshaft position sensor ☞ page F2-46
3	Is fuel injector at cylinder No.3 OK? ☞ page F2-126	Yes No	Go to next step Repair or replace fuel injector at cylinder No.3 ☞ page F2-22
4	Is fuel system OK? ☞ page F2-11	Yes No	Go to next step Repair or replace as necessary
5	Is exhaust gas recirculation system OK? ☞ page F2-130	Yes No	Go to next step Repair or replace as necessary
6	Is compression at cylinder No.3 normal? ☞ section B2	Yes No	Go to next step Repair or replace as necessary
7	Erase diagnostic trouble code from memory. Is same code No. present after *rechecking?	Yes No	Replace PCM ☞ page F2-36 Temporary system malfunction

* During normal driving

Diagnostic trouble code No. P0304		CYLINDER 4 MISFIRE DETECTED	
Symptom		PCM input signal from crankshaft position sensor signal for cylinder No.4 is irregular	
Possible cause		<ul style="list-style-type: none"> • Ignition system of cylinder No.4 malfunction • Low fuel • Low battery positive voltage • Fuel system malfunction • Insufficient compression in cylinder No.4 • Crankshaft position sensor air gap incorrect • Exhaust gas recirculation system malfunction 	
STEP	INSPECTION		ACTION
1	Is ignition system of cylinder No.4 OK? ☞ section G	Yes	Go to next step
		No	Repair or replace as necessary
2	Is crankshaft position sensor air gap OK? ☞ page F2-46	Yes	Go to next step
		No	Repair or replace crankshaft position sensor ☞ page F2-46
3	Is fuel injector at cylinder No.4 OK? ☞ page F2-126	Yes	Go to next step
		No	Repair or replace fuel injector at cylinder No.4 ☞ page F2-22
4	Is fuel system OK? ☞ page F2-11	Yes	Go to next step
		No	Repair or replace as necessary
5	Is exhaust gas recirculation system OK? ☞ page F2-130	Yes	Go to next step
		No	Repair or replace as necessary
6	Is compression at cylinder No.4 normal? ☞ section B2	Yes	Go to next step
		No	Repair or replace as necessary
7	Erase diagnostic trouble code from memory. Is same code No. present after *rechecking?	Yes	Replace PCM ☞ page F2-36
		No	Temporary system malfunction

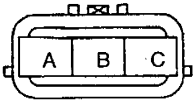
* During normal driving







Diagnostic trouble code No. P0335		CRANKSHAFT POS SENSOR—CKT MALFUNCTION	
Symptom		No NE signal input from crankshaft position sensor for 1.5 seconds while engine running	
Possible cause		<ul style="list-style-type: none"> • Crankshaft position sensor malfunction • Open or short circuit in wiring from PCM terminal 4E to crankshaft position sensor terminal B • Open or short circuit in wiring from PCM terminal 4H to crankshaft position sensor terminal A 	
STEP	INSPECTION		ACTION
1	Does crankshaft position sensor connector or PCM connector have poor connection?	Yes	Repair or replace connector
		No	Go to next step
2	Disconnect crankshaft position sensor connector. Is there continuity between harness side connector terminal B and PCM terminal 4E? Is there continuity between harness side connector terminal A and PCM terminal 4H?	Yes	Go to next step
		No	Repair or replace wiring harness
3	Is crankshaft position sensor air gap OK? ☞ page F2-46	Yes	Go to next step
		No	Replace crankshaft position sensor or crankshaft pulley ☞ page F2-46 ☞ section B2
4	Is crankshaft position sensor OK? ☞ page F2-45	Yes	Go to next step
		No	Replace crankshaft position sensor ☞ page F2-46
5	Erase diagnostic trouble code from memory. Is same code No. present after rechecking?	Yes	Replace PCM ☞ page F2-36
		No	Intermittent poor connection of harness or connector (Repair connector and/or harness)
 <p>HARNESS SIDE CONNECTOR (VIEW FROM BEHIND OF CONNECTOR)</p>			

Diagnostic trouble code No. P0340		CAMSHAFT POS SENSOR—CKT MALFUNCTION	
Symptom		No SGT signal input from camshaft position sensor for 4.2 seconds while engine running	
Possible cause		<ul style="list-style-type: none"> • Camshaft position sensor malfunction • Open or short circuit in wiring from PCM terminal 4F to distributor terminal C • Open or short circuit in wiring from PCM terminal 4A to distributor terminal A 	
STEP	INSPECTION		ACTION
1	Does distributor connector or PCM connector have poor connection?	Yes	Repair or replace connector
		No	Go to next step
2	Disconnect distributor connector. Is there continuity between harness side connector terminal C and PCM terminal 4F? Is there continuity between harness side connector terminal A and PCM terminal 4A?	Yes	Go to next step
		No	Repair or replace wiring harness
3	Is camshaft position sensor OK?  page F2-45	Yes	Go to next step
		No	Replace distributor  section G
4	Erase diagnostic trouble code from memory. Is same code No. present after rechecking?	Yes	Replace PCM
		No	Intermittent poor connection of harness or connector (Repair connector and/or harness)
 <p>HARNESS SIDE CONNECTOR (VIEW FROM BEHIND OF CONNECTOR)</p>			



Diagnostic trouble code No. P0400	EGR—FLOW MALFUNCTION		
Symptom	Exhaust gas recirculation system does not function normally because of electrical or mechanical trouble		
Possible cause	<ul style="list-style-type: none"> • EGR valve malfunction • EGR boost sensor malfunction • EGR boost sensor solenoid valve malfunction • EGR valve position sensor malfunction • EGR solenoid valve (vacuum, vent) malfunction • Clogs or leakage in piping connecting following units <ul style="list-style-type: none"> • EGR boost sensor, EGR boost sensor solenoid valve and intake manifold • Air cleaner, EGR solenoid valve (vent) and EGR valve • Intake manifold, EGR solenoid valve (vacuum) and EGR valve 		
STEP	INSPECTION		ACTION
1	Is diagnostic trouble code for EGR solenoid valve (vacuum, vent), EGR boost sensor solenoid valve or EGR boost sensor displayed?	Yes	Carry out inspection as required according to diagnostic trouble code
		No	Go to next step
2	Is EGR valve position sensor OK? 🔧 page F2-49	Yes	Go to next step
		No	Repair or replace EGR valve 🔧 page F2-32
3	Check each hose for damage. Are they OK? • Intake manifold—EGR solenoid valve (vent) • EGR solenoid valve (vent)—EGR solenoid valve (vacuum) • EGR solenoid valve (vacuum)—EGR valve	Yes	Go to next step
		No	Repair or replace as necessary
4	EGR boost sensor OK? 🔧 page F2-50	Yes	Go to next step
		No	Replace EGR boost sensor 🔧 page F2-35
5	Check each hose for damage. Are they OK? • EGR passage—EGR boost sensor solenoid valve • EGR boost sensor—EGR boost sensor solenoid valve	Yes	Go to next step
		No	Repair or replace as necessary
6	Erase diagnostic trouble code from memory. Is same code No. present after *rechecking?	Yes	Replace PCM 🔧 page F2-36
		No	Temporary system malfunction



* During driving when coolant temperature is over 55 ° C { 131 ° F } and engine speed is over 1,000 rpm [10 km/h { 6.2 mph }]





Diagnostic trouble code No. P0420	BANK 1 CAT EFFICIENCY BELOW LIMIT		
Symptom	<ul style="list-style-type: none"> • Three way catalytic converter deterioration • Leakage in exhaust system 		
STEP	INSPECTION		ACTION
1	Is heated oxygen sensor (Rear) OK? 🔧 page F2-48	Yes	Replace three way catalytic converter 🔧 page F2-26
		No	Replace heated oxygen sensor (Rear) 🔧 page F2-35

Diagnostic trouble code No. P0440		EVAP SYSTEM—MALFUNCTION	
Symptom		Evaporative emission control system does not function normally because of mechanical trouble	
Possible cause		<ul style="list-style-type: none"> • Purge solenoid valve malfunction • Charcoal canister malfunction • Check valve malfunction • Fuel vapor valve malfunction • Clogs or leakage in piping connecting following units <ul style="list-style-type: none"> • Intake manifold and purge solenoid valve • Purge solenoid valve and charcoal canister • Charcoal canister, check valve, and fuel vapor valve 	
STEP	INSPECTION		ACTION
1	Is PCM terminal 4T voltage OK?  page F2-39	Yes	Go to next step
		No	Inspect purge solenoid valve  page F2-32
2	Are evaporative emission control system-related hose free of clogs and leakage?	Yes	Go to next step
		No	Repair or replace as necessary
3	Is charcoal canister OK?  page F2-31	Yes	Go to next step
		No	Repair or replace as necessary
4	Is check valve OK?  page F2-31	Yes	Go to next step
		No	Repair or replace as necessary
5	Is rollover valve OK?  page F2-31	Yes	Go to next step
		No	Repair or replace as necessary
6	Erase diagnostic trouble code from memory. Is same code No. present after *rechecking?	Yes	Replace PCM  page F2-36
		No	Temporary system malfunction

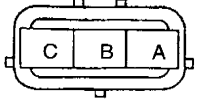

* During driving after engine warm-up

Diagnostic trouble code No. P0443		EVAP SYSTEM—PURGE CTRL VALVE CKT MALF	
Symptom		Open or short circuit is observed in purge solenoid valve system when ignition switch is turned on	
Possible cause		<ul style="list-style-type: none"> • Purge solenoid valve malfunction • Open or short circuit in wiring from purge solenoid valve terminal A to main relay terminal D • Open or short circuit in wiring from purge solenoid valve terminal B to PCM terminal 4T 	
STEP	INSPECTION	ACTION	
1	Does purge solenoid valve connector or PCM connector have poor connection?	Yes	Repair or replace connector
		No	Go to next step
2	Is PCM terminal 4T voltage OK?  page F2-39	Yes	Go to step 6
		No	Go to next step
3	Disconnect purge solenoid valve connector. Turn ignition switch to ON. Is there battery positive voltage at harness side connector terminal A?	Yes	Go to next step
		No	Check for open or short circuit in wiring harness. (Main relay terminal D — Purge solenoid valve terminal A)
4	Is there continuity between harness side connector terminal B and PCM terminal 4T?	Yes	Go to next step
		No	Repair or replace wiring harness
5	Is there continuity between purge solenoid valve connector terminals A and B?	Yes	Go to next step
		No	Replace purge solenoid valve
6	Erase diagnostic trouble code from memory. Is same code No. present after rechecking?	Yes	Replace PCM  page F2-36
		No	Intermittent poor connection of harness or connector (Repair connector and/or harness)
 <p>HARNESS SIDE CONNECTOR (VIEW FROM BEHIND OF CONNECTOR)</p>			

Diagnostic trouble code No. P0450		EVAP SYSTEM—PRESSURE SEN MALFUNCTION	
Symptom		Input voltage from fuel tank pressure sensor is below 0.1 V or above 4.8 V when ignition switch is turned on	
Possible cause		<ul style="list-style-type: none"> • Fuel tank pressure sensor malfunction • Open or short circuit in wiring from PCM terminal 3I to fuel tank pressure sensor terminal C • Open or short circuit in wiring from PCM terminal 3A to fuel tank pressure sensor terminal B • Open circuit in wiring from PCM terminal 3O to fuel tank pressure sensor terminal A 	
STEP	INSPECTION		ACTION
1	Does fuel tank pressure sensor connector or PCM connector have poor connection?	Yes	Repair or replace connector
		No	Go to next step
2	Is PCM terminal 3A voltage OK?  page F2-39	Yes	Go to step 6
		No	Go to next step
3	Are fuel tank pressure sensor and connecting hose free of freezing, breakage, and clogs?	Yes	Repair or replace
		No	Go to next step
4	Disconnect fuel tank pressure sensor connector. Turn ignition switch to ON. Is there 5 V at harness side connector terminal A?	Yes	Go to next step
		No	Check for open or short circuit in wiring harness. (PCM terminal 3I — Fuel tank pressure sensor terminal C)
5	Is fuel tank pressure sensor OK?  page F2-51	Yes	Replace fuel tank pressure sensor
		No	Repair or replace wiring harness
6	Erase diagnostic trouble code from memory. Is same code present after rechecking?	Yes	Replace PCM  page F2-36
		No	Intermittent poor connector of harness or connector (Repair connector and/or harness)
 <p>HARNESS SIDE CONNECTOR (VIEW FROM BEHIND OF CONNECTOR)</p>			

Diagnostic trouble code No. P0500		VEHICLE SPEED SENSOR—MALFUNCTION	
Symptom		No vehicle speed sensor signal input from vehicle speed sensor while driving	
Possible cause		<ul style="list-style-type: none"> • Speedometer sensor malfunction • Open or short circuit in wiring from ignition switch to speedometer sensor • Open or short circuit in wiring from speedometer sensor to GND • Open or short circuit in wiring from speedometer sensor to vehicle speed sensor • Open or short circuit in wiring from vehicle speed sensor to PCM terminal 1M 	
STEP	INSPECTION		ACTION
1	Does vehicle speed sensor connector or PCM connector have poor connection?	Yes	Repair or replace connector
		No	Go to next step
2	Is PCM terminal 1M voltage OK?  page F2-39	Yes	Go to step 5
		No	Go to next step
3	Is there continuity between vehicle speed sensor terminal and PCM terminal 1M?	Yes	Go to next step
		No	Repair or replace wiring harness
4	Is there continuity between vehicle speed sensor and speedometer sensor terminals?  section T	Yes	Go to next step
		No	Repair or replace speedometer sensor and wiring harness  section T
5	Erase diagnostic trouble code from memory. Is same code No. present after rechecking?	Yes	Replace PCM  page F2-36
		No	Intermittent poor connection of harness or connector (Repair connector and/or harness)

Diagnostic trouble code No. P0505		IDLE CONTROL SYSTEM—MALFUNCTION	
Symptom		<ul style="list-style-type: none"> • Mechanical trouble is observed in idle air control system • Open or short circuit is observed in idle air control system when ignition switch is turned on 	
Possible cause		<ul style="list-style-type: none"> • Idle air control valve malfunction • Leakage in intake-air system • Open or short circuit in wiring from idle air control valve terminal A to main relay terminal D • Open or short circuit in wiring from idle air control valve terminal B to PCM terminal 4Q 	
STEP	INSPECTION		ACTION
1	Does idle air control valve connector or PCM connector have poor connection?	Yes	Repair or replace connector
		No	Go to next step
2	Is PCM terminal 4Q voltage OK? 🔧 page F2-39	Yes	Go to step 6
		No	Go to next step
3	Disconnect idle air control valve connector. Turn ignition switch to ON. Is there battery positive voltage at harness side connector terminal A?	Yes	Go to next step
		No	Check for open or short circuit in wiring harness. (Main relay terminal D — Idle air control valve terminal A)
4	Is there continuity between harness side connector terminal B and PCM terminal 4Q?	Yes	Go to next step
		No	Repair or replace wiring harness
5	Is there continuity between idle air control valve connector terminals A and B?	Yes	Go to next step
		No	Replace BAC valve 🔧 page F2-7
6	Erase diagnostic trouble code from memory. Is same code No. present after rechecking?	Yes	Replace PCM 🔧 page F2-36
		No	Intermittent poor connection of harness or connector (Repair connector and/or harness)
 <p>HARNESS SIDE CONNECTOR (VIEW FROM BEHIND OF CONNECTOR)</p>			

Diagnostic trouble code No. P0703		TORQUE CONV/BRAKE SW—MALFUNCTION	
Symptom		No signal input from brake switch to PCM when brake pedal is kept depressed for more than 33 seconds, or signal input when brake pedal is not depressed for more than 15 seconds	
Possible cause		<ul style="list-style-type: none"> • Brake switch malfunction • Open or short circuit in wiring from PCM terminal 1Q to brake switch terminal • Open or short circuit in wiring from brake switch terminal to battery terminal 	
STEP	INSPECTION		ACTION
1	Does brake switch connector or PCM connector have poor connection?	Yes	Repair or replace
		No	Go to next step
2	Is PCM terminal 1Q voltage OK?  page F2-39	Yes	Go to step 4
		No	Go to next step
3	Is there continuity between brake switch terminal and PCM terminal 1Q?	Yes	Check for open or short circuit in wiring harness. (Battery — Brake switch) Check brake switch.  section P
		No	Repair or replace wiring harness
4	Erase diagnostic trouble code from memory. Is same code No. present after rechecking?	Yes	Replace PCM  page F2-36
		No	Intermittent poor connection of harness or connector (Repair connector and/or harness)



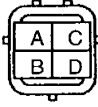

Diagnostic trouble code No. P1000	MORE DRIVING NEEDED TO COMPLETE TEST	
Possible cause	Following diagnostic trouble code detection conditions not satisfied	
	Diagnosed circuit	Code No.
	Excessive time to enter closed loop fuel control	P0125
	O ₂ sensor circuit malfunction	P0130
	O ₂ sensor heater circuit malfunction	P0135
	Fuel trim malfunction	P0170
	Random misfire detected	P0300
	Cylinder 1 misfire detected	P0301
	Cylinder 2 misfire detected	P0302
	Cylinder 3 misfire detected	P0303
	Cylinder 4 misfire detected	P0304
Exhaust gas recirculation flow malfunction	P0400	
Catalyst system efficiency below threshold	P0420	
Evaporative emission control system malfunction	P0440	
Note		
<ul style="list-style-type: none"> • DTC No.P1000 will be deleted while the MIL is illuminated 		

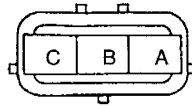
Diagnostic trouble code No. P1170		HO2S 11—INVERSION	
Symptom		Heated oxygen sensor (Front) signal remains unchanged for more than 20 seconds after engine is in feedback zone	
Possible cause		<ul style="list-style-type: none"> • Low fuel • Heated oxygen sensor (Front) malfunction • Open or short circuit in wiring from heated oxygen sensor (Front) terminal A to PCM terminal 3C • Intake-air system, fuel system, ignition system malfunction 	
STEP	INSPECTION	ACTION	
1	Does heated oxygen sensor (Front) connector or PCM connector have poor connection?	Yes	Repair or replace connector
		No	Go to next step
2	Is PCM terminal 3C voltage OK? ☞ page F2-39	Yes	Go to step 5
		No	Go to next step
3	Disconnect heated oxygen sensor (Front) connector. Is there continuity between harness side connector terminal A and PCM terminal 3C?	Yes	Go to next step
		No	Repair or replace wiring harness
4	Are following units OK? Fuel injector ☞ page F2-22 Pressure regulator ☞ page F2-23 Mass air flow sensor ☞ page F2-44 Engine coolant temperature sensor ☞ page F2-48 Spark plug ☞ section G Air suction (Air/Fuel ratio rich or lean)	Yes	Replace heated oxygen sensor (Front) ☞ page F2-35
		No	Repair or replace
5	Erase diagnostic trouble code from memory. Is same code No. present after rechecking?	Yes	Replace PCM ☞ page F2-36
		No	Intermittent poor connection of harness or connector (Repair connector and/or harness)
 <p>HARNESS SIDE CONNECTOR (VIEW FROM BEHIND OF CONNECTOR)</p>			

Diagnostic trouble code No. P1195	EGRBS—OPEN OR SHORT		
Symptom	Input voltage from EGR boost sensor is below 0.1 V or above 4.9 V when ignition switch is turned on		
Possible cause	<ul style="list-style-type: none"> • EGR boost sensor malfunction • Open or short circuit in wiring from PCM terminal 3H to EGR boost sensor terminal B • Open or short circuit in wiring from PCM terminal 3I to EGR boost sensor terminal C • Open circuit in wiring from PCM terminal 3O to EGR boost sensor terminal A 		
STEP	INSPECTION		ACTION
1	Does EGR boost sensor connector or PCM connector have poor connection?	Yes	Repair or replace connector
		No	Go to next step
2	Is PCM terminal 3H voltage OK? 🔧 page F2-39	Yes	Go to step 5
		No	Go to next step
3	Disconnect EGR boost sensor connector. Turn ignition switch to ON. Is there 5V at harness side connector terminal C?	Yes	Go to next step
		No	Check for open or short circuit in wiring harness. (PCM terminal 3I — EGR boost sensor terminal C)
4	Is there continuity between connector terminal A and PCM terminal 3O?	Yes	Replace EGR boost sensor
		No	Repair or replace wiring harness.
5	Erase diagnostic trouble code from memory. Is same code No. present after rechecking?	Yes	Replace PCM 🔧 page F2-36
		No	Intermittent poor connection of harness or connector (Repair connector and/or harness.)



HARNESS SIDE CONNECTOR
(VIEW FROM BEHIND OF CONNECTOR)

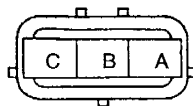

Diagnostic trouble code No. P1250		PRC OPEN OR SHORT	
Symptom		Open or short circuit is observed in PRC solenoid valve system when ignition switch is turned on	
Possible cause		<ul style="list-style-type: none"> • PRC solenoid valve malfunction • Open or short circuit in wiring from PRC solenoid valve terminal A to main relay terminal D • Open or short circuit in wiring from PRC solenoid valve terminal B to PCM terminal 4J 	
STEP	INSPECTION	ACTION	
1	Does PRC solenoid valve connector or PCM connector have poor connection?	Yes	Repair or replace connector
		No	Go to next step
2	Is PCM terminal 4J voltage OK?  page F2-39	Yes	Go to step 6
		No	Go to next step
3	Disconnect PRC solenoid valve connector. Turn ignition switch to ON. Is there battery positive voltage at harness side connector terminal A?	Yes	Go to next step
		No	Check for open or short circuit in wiring harness. (Main relay terminal D — PRC solenoid valve terminal A)
4	Is there continuity between harness side connector terminal B and PCM terminal 4J?	Yes	Go to next step
		No	Repair or replace wiring harness
5	Is there continuity between PRC solenoid valve terminals A and B?	Yes	Go to next step
		No	Replace PRC solenoid valve  page F2-12
6	Erase diagnostic trouble code from memory. Is same code No. present after rechecking?	Yes	Replace PCM  page F2-36
		No	Intermittent poor connection of harness or connector (Repair connector and/or harness)
 <p>HARNESS SIDE CONNECTOR (VIEW FROM BEHIND OF CONNECTOR)</p>			

Diagnostic trouble code No. P1402		EGRS—OPEN OR SHORT	
Symptom		Input voltage from EGR valve position sensor is below 0.2 V or above 4.8 V when ignition switch is turned on	
Possible cause		<ul style="list-style-type: none"> • EGR valve position sensor malfunction • Open or short circuit in wiring from EGR valve position sensor terminal B to PCM terminal 3I • Open or short circuit in wiring from EGR valve position sensor terminal C to PCM terminal 3J • Open or short circuit in wiring from EGR valve position sensor terminal A to PCM terminal 3O 	
STEP	INSPECTION	ACTION	
1	Does EGR valve position sensor connector or PCM connector have poor connection?	Yes	Repair or replace connector
		No	Go to next step
2	Is PCM terminal 3J voltage OK? 🔧 page F2-39	Yes	Go to step 7
		No	Go to next step
3	Disconnect EGR valve position sensor connector. Turn ignition switch ON. Is there 5 V at harness side connector terminal B?	Yes	Go to next step
		No	Check for open or short circuit in wiring harness. (PCM terminal 3I — EGR valve position sensor terminal B)
4	Is there continuity between harness side connector terminal C and PCM terminal 3J?	Yes	Go to next step
		No	Repair or replace wiring harness
5	Is there continuity between harness side connector terminal A and PCM terminal 3O?	Yes	Go to next step
		No	Repair or replace wiring harness
6	Is resistance of EGR valve position sensor OK? 🔧 page F2-49	Yes	Go to next step
		No	Replace EGR valve 🔧 page F2-30
7	Erase diagnostic trouble code from memory. Is same code No. present after rechecking?	Yes	Replace PCM 🔧 page F2-36
		No	Intermittent poor connection of harness or connector (Repair connector and/or harness)







HARNESS SIDE CONNECTOR
(VIEW FROM BEHIND OF CONNECTOR)

Diagnostic trouble code No. P1449	CDCV—OPEN OR SHORT
Symptom	Open or short circuit is observed in canister drain cut valve or tank pressure control valve system when ignition switch is turned on
Possible cause	<ul style="list-style-type: none"> • Canister drain cut valve malfunction • Tank pressure control valve malfunction • Open or short circuit in wiring from canister drain cut valve terminal A to main relay terminal D • Open or short circuit in wiring from canister drain cut valve terminal B to PCM terminal 4Z • Open or short circuit in wiring from tank pressure control valve terminal A to main relay terminal D • Open or short circuit in wiring from tank pressure control valve terminal B to PCM terminal 4Z



STEP	INSPECTION		ACTION
1	Does canister drain cut valve connector, tank pressure control valve connector or PCM connector have poor connection?	Yes	Repair or replace connector
		No	Go to next step
2	Is PCM terminal 4Z voltage OK?  page F2-39	Yes	Go to step
		No	Go to next step
3	Disconnect canister drain cut valve connector. Turn ignition switch to ON. Is there battery positive voltage at harness side connector terminal A?	Yes	Go to next step
		No	Check for open or short circuit in wiring harness (Main relay terminal D — Canister drain cut valve terminal A)
4	Disconnect tank pressure control valve connector. Turn ignition switch to ON. Is there battery positive voltage at harness side connector terminal A?	Yes	Go to next step
		No	Check for open or short circuit in wiring harness (Main relay terminal D — Tank pressure control valve terminal A)
5	Is there continuity between canister drain cut valve harness side connector terminal B and PCM terminal 4Z?	Yes	Go to next step
		No	Repair or replace wiring harness
6	Is there continuity between tank pressure control valve harness side connector terminal B and PCM terminal 4Z?	Yes	Go to next step
		No	Repair or replace wiring harness
7	Is there continuity between canister drain cut valve terminals A and B?	Yes	Go to next step
		No	Replace canister drain cut valve
8	Is there continuity between tank pressure control valve terminals A and B?	Yes	Go to next step
		No	Replace tank pressure control valve
9	Erase diagnostic trouble code from memory. Is same code No. present after rechecking?	Yes	Replace PCM  page F2-36
		No	Intermittent poor connection of harness or connector (Repair connector and/or harness)



TPCV, CDCV
HARNESS SIDE CONNECTOR
(VIEW FROM BEHIND OF CONNECTOR)

Diagnostic trouble code No. P1455		FUEL TANK LEVEL SENSOR—OPEN OR SHORT	
Symptom		Input voltage from fuel tank level sensor is 0 V or above 4.98 V when ignition switch is turned on	
Possible cause		<ul style="list-style-type: none"> Fuel gauge sender unit malfunction Open or short circuit in wiring from fuel pump connector terminal C to PCM terminal 4M 	
STEP	INSPECTION	ACTION	
1	Does fuel pump connector or PCM 4M connector have poor connection?	Yes	Repair or replace connector
		No	Go to next step
2	Is PCM terminal 4M voltage OK?  page F2-39	Yes	Go to step 7
		No	Go to next step
3	Is there continuity between fuel pump side connector terminal C and PCM terminal 4M?	Yes	Go to next step
		No	Repair or replace wiring harness
4	Is fuel gauge sender unit OK?  section T	Yes	Go to next step
		No	Replace fuel gauge sender unit
5	Is fuel gauge OK?  section T	Yes	Go to next step
		No	Repair or replace
6	Is there continuity between fuel pump harness side connector terminal C and instrument cluster?	Yes	Go to step 7
		No	Repair or replace wiring harness
7	Erase diagnostic trouble code from memory. Is same code No. present after rechecking?	Yes	Replace PCM
		No	Intermittent poor connection of harness or connector (Repair connector and/or harness)
 <p>HARNESS SIDE CONNECTOR (VIEW FROM BEHIND OF CONNECTOR)</p>			

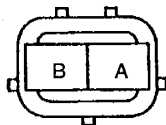

Diagnostic trouble code No. P1485	EGR (VACUUM)—OPEN OR SHORT
Symptom	Open or short circuit is observed in EGR solenoid valve (vacuum) system when ignition switch is turned on
Possible cause	<ul style="list-style-type: none"> • EGR solenoid valve (vacuum) malfunction • Open or short circuit in wiring from EGR solenoid valve (vacuum) terminal A to main relay terminal D • Open or short circuit in wiring from EGR solenoid valve (vacuum) terminal B to PCM terminal 4P

STEP	INSPECTION		ACTION
1	Does EGR solenoid valve (vacuum) connector or PCM connector have poor connection?	Yes	Repair or replace connector
		No	Go to next step
2	Is PCM terminal 4P voltage OK?  page F2-39	Yes	Go to step 6
		No	Go to next step
3	Disconnect EGR solenoid valve connector. Turn ignition switch to ON. Is there battery positive voltage at harness side connector terminal A?	Yes	Go to next step
		No	Check for open or short circuit in wiring harness. [Main relay terminal D — EGR solenoid valve (vacuum) terminal A]
4	Is there continuity between harness side connector terminal B and PCM terminal 4P?	Yes	Go to next step
		No	Repair or replace wiring harness
5	Is there continuity between EGR solenoid valve (vacuum) terminals A and B?	Yes	Go to next step
		No	Replace EGR solenoid valve (vacuum)  page F2-33
6	Erase diagnostic trouble code from memory. Is same code No. present after rechecking?	Yes	Replace PCM  page F2-36
		No	Intermittent poor connection of harness or connector (Repair connector and/or harness)



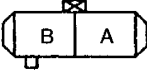

HARNESS SIDE CONNECTOR
(VIEW FROM BEHIND OF CONNECTOR)

Diagnostic trouble code No. P1486		EGR (VENT)—OPEN OR SHORT	
Symptom		Open or short circuit is observed in EGR solenoid valve (vent) system when ignition switch is turned on	
Possible cause		<ul style="list-style-type: none"> • EGR solenoid valve (vent) malfunction • Open or short circuit in wiring from EGR solenoid valve (vent) terminal A to main relay terminal D • Open or short circuit in wiring from EGR solenoid valve (vent) terminal B to PCM terminal 4O 	
STEP	INSPECTION		ACTION
1	Does EGR solenoid valve (vent) connector or PCM connector have poor connection?	Yes	Repair or replace connector
		No	Go to next step
2	Is PCM terminal 4O voltage OK? ☞ page F2-39	Yes	Go to step 6
		No	Go to next step
3	Disconnect EGR solenoid valve (vent) connector. Turn ignition switch to ON. Is there battery positive voltage at harness side connector terminal A?	Yes	Go to next step
		No	Check for open or short circuit in wiring harness. [Main relay terminal D — EGR solenoid valve (vent) terminal A]
4	Is there continuity between harness side connector terminal B and PCM terminal 4O?	Yes	Go to next step
		No	Repair or replace wiring harness
5	Is there continuity between EGR solenoid valve (vent) terminals A and B?	Yes	Go to next step
		No	Replace EGR solenoid valve (vent) ☞ page F2-33
6	Erase diagnostic trouble code from memory. Is same code No. present after rechecking?	Yes	Replace PCM ☞ page F2-36
		No	Intermittent poor connection of harness or connector (Repair connector and/or harness)
 <p>HARNESS SIDE CONNECTOR (VIEW FROM BEHIND OF CONNECTOR)</p>			



Diagnostic trouble code No. P1487	EGRCHK SOL.—OPEN OR SHORT		
Symptom	Open or short circuit is observed in EGR boost sensor solenoid valve system when ignition switch is turned on		
Possible cause	<ul style="list-style-type: none"> • EGR boost sensor solenoid valve malfunction • Open or short circuit in wiring from EGR boost sensor solenoid valve terminal A to main relay terminal D • Open or short circuit in wiring from EGR boost sensor solenoid valve B to PCM terminal 4L 		
STEP	INSPECTION		ACTION
1	Does EGR boost sensor solenoid valve connector or PCM connector have poor connection?	Yes	Repair or replace connector
		No	Go to next step
2	Is PCM terminal 4P voltage OK?  page F2-39	Yes	Go to step 6
		No	Go to next step
3	Disconnect EGR boost sensor solenoid valve connector. Turn ignition switch to ON. Is there battery positive at harness side connector terminal A?	Yes	Go to next step
		No	Check for open or short circuit in wiring harness (Main relay terminal D — EGR boost sensor solenoid valve terminal A)
4	Is there continuity between harness side connector terminal B and PCM terminal 4P?	Yes	Go to next step
		No	Repair or replace wiring harness
5	Is there continuity between EGR boost sensor solenoid valve terminals A and B?	Yes	Go to next step
		No	Replace EGR boost sensor solenoid valve  page F2-33
6	Erase diagnostic trouble code from memory. Is same code No. present after rechecking?	Yes	Replace PCM  page F2-36
		No	Intermittent poor connection of harness or connector (Repair connector and/or harness)



HARNESS SIDE CONNECTOR
(VIEW FROM BEHIND OF CONNECTOR)

Diagnostic trouble code No. P1523		VICS—OPEN OR SHORT	
Symptom		Open or short circuit is observed in VICS solenoid valve system when ignition switch is turned on	
Possible cause		<ul style="list-style-type: none"> • VICS solenoid valve malfunction • Open or short circuit in wiring from ignition switch to VICS solenoid valve, and from VICS solenoid valve to PCM terminal 4K 	
STEP	INSPECTION		ACTION
1	Does VICS solenoid valve connector PCM connector have poor connection?	Yes	Repair or replace connector
		No	Go to next step
2	Disconnect purge solenoid valve connector. Turn ignition switch is ON. Is there battery positive voltage at harness side connector terminal A?	Yes	Go to next step
		No	Check for open or short circuit in wiring harness. (Harness side connector terminal A — Main relay)
3	Is there continuity between harness side connector terminal B and PCM terminal 4K?	Yes	Go to next step
		No	Repair or replace wiring harness
4	Is there continuity between VICS solenoid valve terminals?  page F2-9	Yes	Go to next step
		No	Replace VICS solenoid valve
5	Erase diagnostic trouble code from memory. Is same code No. present after rechecking?	Yes	Replace PCM  page F2-36
		No	Intermittent poor connection of harness or connector (Repair or replace onconnector and/or harness)
 <p>HARNESS SIDE CONNECTOR (VIEW FROM BEHIND OF CONNECTOR)</p>			

Diagnostic trouble code No. P1608		PCME (CPU)—MALFUNCTION	
Symptom		PCM does not read diagnostic trouble codes from output devices	
Possible cause		<ul style="list-style-type: none"> • PCM malfunction 	
STEP	INSPECTION		ACTION
—	—		Replace PCM  page F2-36

Diagnostic trouble code No. P1794		BAT—BAT OR CIRCUIT FAIL	
Symptom		Battery positive voltage is not constantly applied to PCM terminal 4I	
Possible cause		<ul style="list-style-type: none"> • Battery malfunction • Open or short circuit in wiring from PCM terminal 4I to positive battery cable • Burnt fuse 	
STEP	INSPECTION		ACTION
1	Is battery fully charged?  section G	Yes	Go to next step
		No	Charge battery  section G
2	Does battery positive voltage present at PCM terminal 4I?	Yes	Go to next step
		No	Check for open or short circuit in wiring harness (PCM terminal 4I — Battery)
3	Erase diagnostic trouble code from memory. Is same code No. present after rechecking?	Yes	Replace PCM  page F2-36
		No	Intermittent poor connection of harness or connector (Repair connector and/or harness)

Diagnostic trouble code No. P1797		PNS—OPEN OR SHORT	
Symptom		<ul style="list-style-type: none"> • PCM judges N position for more than 33 seconds when shift lever is in D range • PCM judges neutral/clutch switch OFF for more than 5 seconds while vehicle stopped and engine running 	
Possible cause		<ul style="list-style-type: none"> • Transaxle range switch malfunction • Clutch/neutral switch malfunction • PCM malfunction • Open or short circuit in wiring from transaxle range switch terminal H or neutral/clutch switch terminal to PCM terminal 1L 	
STEP	INSPECTION		ACTION
1	Does PCM connector have poor connection?	Yes	Repair or replace connector
		No	Go to next step
2	Is PCM terminal 1L voltage OK? ☞ page F2-39	Yes	Go to step 5
		No	Go to next step
3	Is there continuity between transaxle range switch terminal H or clutch/neutral switch terminal and PCM terminal 1L?	Yes	Go to next step
		No	Repair or replace wiring harness
4	(ATX) Is transaxle range switch OK? ☞ section K (MTX) Is neutral/clutch switch OK? ☞ page F2-52	Yes	Go to next step
		No	Repair or replace transaxle range switch or neutral/clutch switch ☞ section K, page F2-52
5	Erase diagnostic trouble code from memory. Is same code No. present after rechecking?	Yes	Replace PCM ☞ page F2-36
		No	Intermittent poor connection of harness or connector (Repair connector and/or harness)

TROUBLESHOOTING

USING THIS SECTION

Procedure

Service section

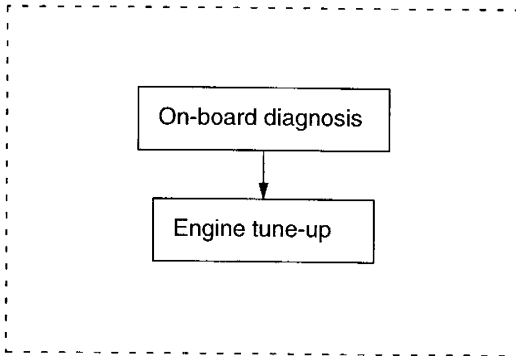

- If diagnostic trouble codes present, carry out inspection required by the code indicated. (Refer to page F2-54.)
- If engine operates, carry out engine tune-up. (Refer to page F2-2.)

Troubleshooting section

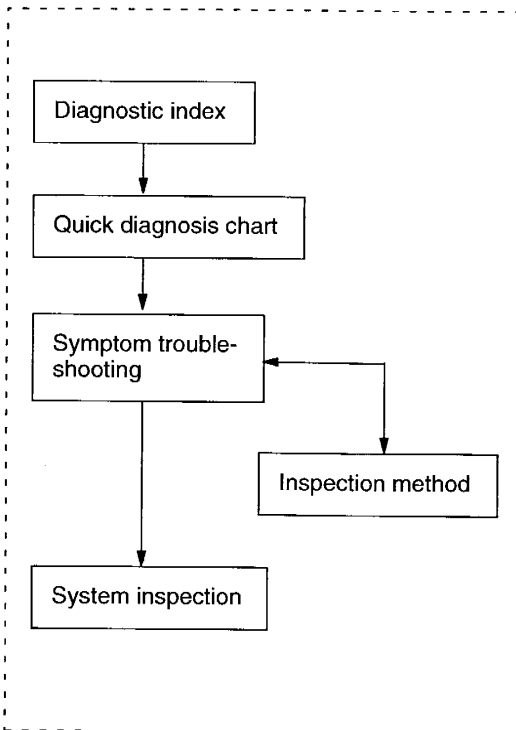

- If problems can not be solved by following procedure in service section, go to troubleshooting section.
- Choose item that most closely corresponds to actual symptom. (Refer to page F2-95.)
- Referring to quick diagnosis chart, assume systems related to the problem. (Refer to page F2-96.)
- Referring to symptom troubleshooting, locate the cause of trouble. (Refer to page F2-98.)
- Inspect the suspected faulty system and repair or replace as necessary.

Description

Diagnostic index

- The diagnostic index is for quick reference of all trouble symptoms in the symptom troubleshooting.
- Detailed description of each symptom enables correct inspection.

DIAGNOSTIC INDEX

No.	TROUBLESHOOTING ITEM	DESCRIPTION	PAGE	
1	Engine hard to start	Discharged battery	F2-100	
2		Will not crank or cranks slowly	F2-100	
3		No combustion	Engine cranks at normal speed but shows no sign of firing	F2-101
4		Combustion observed but engine will not start	Engine shows combustion while cranking but will not continue to run when ignition switch is turned from STA to ON	F2-103
5		Cranks normally but hard to start	Engine cranks at normal speed but requires excessive cranking time before starting Engine runs normally at idle after started	F2-105
6	Idle	Low idle speed/Engine stalls or vibrates	Engine idles at low speed, stalls, or vibrates when engine is cold, hot, or normal temperature	F2-106
7		High idle speed/Idle speed excessively high and will not go down after stop	Idle speed excessively high and will not go down after stop Idle speed excessively high and requires times to be	F2-108

Quick diagnosis chart

- Troubleshooting index shows relationship between trouble symptoms and suspected faulty parts.
- This index is for quick location of the cause of trouble. In case several problems exist, a common cause that may be related to them can also be easily found.

QUICK DIAGNOSIS CHART

Troubleshooting Item	Possible factor																			
	No spark	Incorrect ignition timing	No lead signal always input to PCM	Excessive spark advance	No firing in some cylinders	No fuel supply	Insufficient fuel supply	Fuel injector restrained	Fuel injector clogged	No injector in some cylinder	Throttle position sensor malfunction	Low fuel pressure	Fuel pressure not held	STA signal not input to PCM	Air sucked in	A/F lean during acceleration	A/F rich	Insufficient intake air	Low intake manifold pressure	
1 Discharged battery																				
2 Will not crank slowly																				
3 No combustion	○	●			○															
4 Combustion observed but engine will not start	●	○			○	○	○	○	○	○	○	○	○	○	○	○	○	○	○	○
5 Cranks normally but hard to start													○							
6 Low idle speed/Engine stalls or vibrates																				
7 High idle speed/Idle speed excessively high and will not go down after stop																				

Cause of trouble common to trouble symptoms No.3, 4, 6

Cause of trouble precursor to trouble symptom No.5

Symptom troubleshooting

- Symptom troubleshooting shows diagnosis procedure, inspection method, and proper action to take for each trouble symptom.

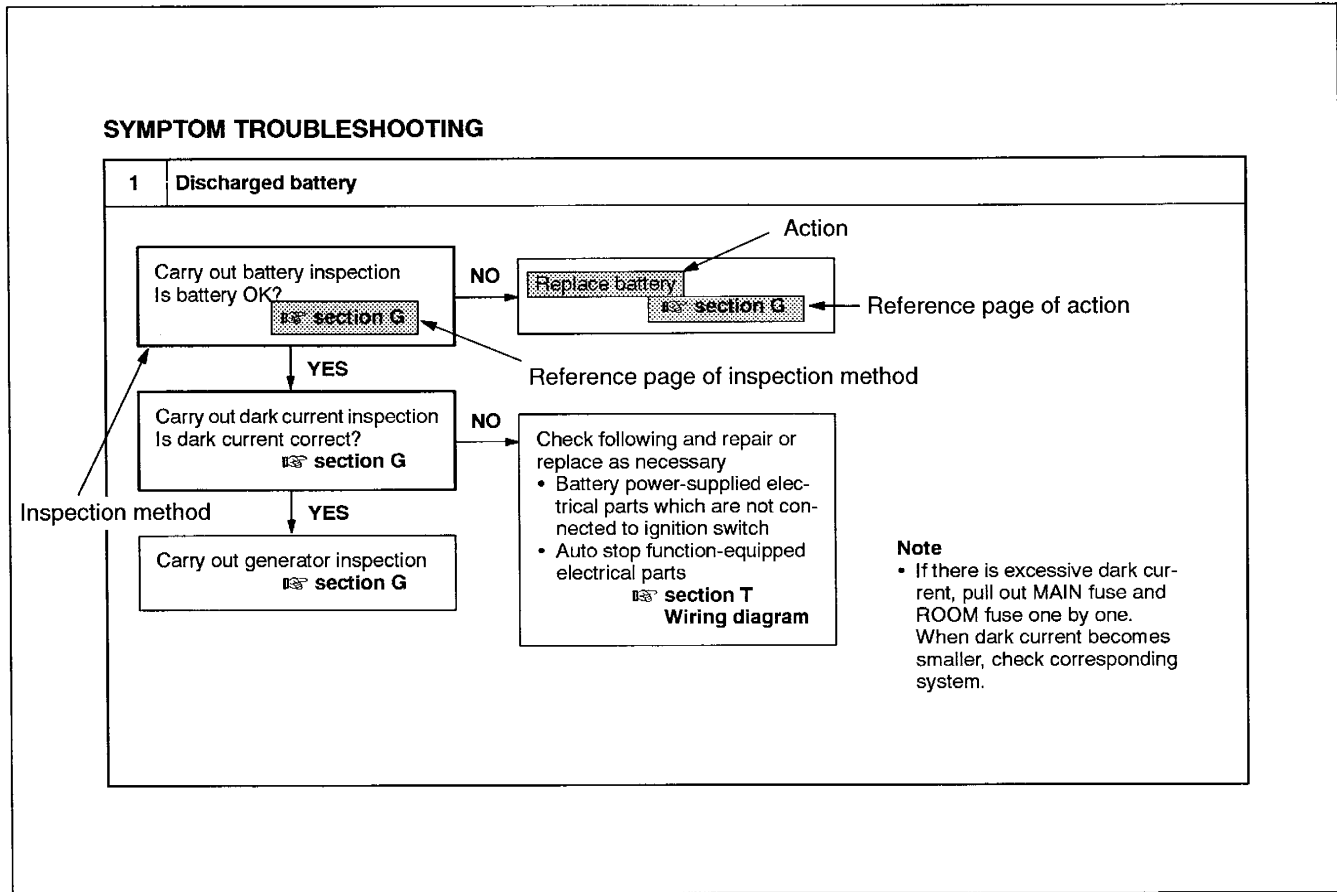

Inspection method

- Inspection methods necessary for troubleshooting are shown per each trouble symptom.
- Efficient troubleshooting is made possible by following this inspection method.

System inspection

- Inspection items necessary for troubleshooting are shown per each system.
- Efficient troubleshooting is made possible by this system inspection.

DIAGNOSTIC INDEX

No.	TROUBLESHOOTING ITEM	DESCRIPTION	PAGE
1	Discharged battery	—	F2-98
2	Will not crank or cranks slowly	—	F2-98
3	No combustion	Engine cranks at normal speed but shows no sign of firing	F2-99
4	Combustion observed but engine will not start	Engine shows combustion while cranking but will not continue to run when ignition switch is turned from STA to ON	F2-100
5	Cranks normally but hard to start	Engine cranks at normal speed but requires excessive cranking time before starting Engine runs normally at idle after started	F2-102
6	Low idle speed/Engine stalls or vibrates	Engine idles at low speed, stalls, or vibrates when engine is cold, hot, or normal temperature	F2-103
7	High idle speed Idle speed remains high	Idle speed excessively high and will not go down after warm-up	F2-105
8	High idle speed Idle speed hard to lower	Idle speed excessively high and requires times to be lowered to normal speed after warm-up	F2-106
9	Rough idle/Engine stalls when E/L, P/S, or A/C ON	Engine runs normally at idle with no load but stalls or vibrates excessively when load (E/L, P/S, or A/C) is ON	F2-106
10	Rough idle/Engine stalls during N-D shift (ATX)	Engine runs normally at idle but stalls or vibrates excessively during N-D shift	F2-107
11	Engine stalls when vehicle about to run	—	F2-108
12	Engine stalls on acceleration and while cruising	—	F2-109
13	Poor acceleration/Insufficient power/Surges while cruising/Hesitates	—	F2-110
14	Runs rough during deceleration/Backfire	Engine runs rough during deceleration, and abnormal combustion occurs in exhaust system	F2-112
15	Knocking	—	F2-113
16	Overheating	—	F2-114
17	Poor fuel economy	Fuel consumption increased excessively though no sudden starting, acceleration, or braking carried out	F2-115
18	Fuel odor	Fuel odor in passenger or engine compartment	F2-116

Possible factor		Troubleshooting item	
Fuel leakage			
Improper fuel			
Low fuel octane number			
PCM not actuated (Include CPU malfunction)			
Improper PCM ground point			
Not fuel cut during deceleration			
Delayed fuel injection recovery timing			
Incorrect fuel amount at fuel injection recovery			
Knocking			
Preignition			
Overheating			
Insufficient air flow amount			
Inoperative radiator			
Coolant leakage			
Poor coolant circulation			
Engine coolant temperature gauge needle points H			
Excessive mechanical resistance		<input type="checkbox"/>	
No compression in all cylinders		<input type="checkbox"/>	
No compression in some cylinders		<input type="checkbox"/>	
High compression ratio			
High compression pressure			
Excessive valve overlap			
Incorrect valve timing			
Insufficient starter power		<input type="checkbox"/>	
Malfunction of starting system-related components		<input type="checkbox"/>	
Higher actual load			
A/C load will not turn off			
Warning light malfunction			
Clutch disc slipping (MTX)			
Brake dragging			
Low tire pressure			
Discharged battery		<input type="checkbox"/>	
Large dark current			
	<input type="checkbox"/>	Discharged battery	1
	<input type="checkbox"/>	Will not crank/ Crank slowly	2
<input type="checkbox"/>	<input type="checkbox"/>	No combustion	3
<input type="checkbox"/>	<input type="checkbox"/>	Combustion observed but engine will not start	4
<input type="checkbox"/>	<input type="checkbox"/>	Crank normally but hard to start	5
<input type="checkbox"/>	<input type="checkbox"/>	Low idle speed/ Engine stalls or vibrates	6
		High idle speed Idle speed remains high	7
		High idle speed Idle speed hard to lower	8
		Rough idle/Engine stalls when E/L, P/S, or A/C ON	9
		Rough idle/Engine stalls during N-D shift (ATX)	10
<input type="checkbox"/>	<input type="checkbox"/>	Engine stalls when vehicle about to run	11
	<input type="checkbox"/>	Engine stalls on acceleration and while cruising	12
<input type="checkbox"/>	<input type="checkbox"/>	Poor acceleration/ Insufficient power/ Surges while cruising/ Hesitates	13
	<input type="checkbox"/>	Runs rough during deceleration/Backfire	14
<input type="checkbox"/>	<input type="checkbox"/>	Knocking	15
<input type="checkbox"/>	<input type="checkbox"/>	Overheating	16
	<input type="checkbox"/>	Poor fuel economy	17
<input type="checkbox"/>		Fuel odor	18

SYMPTOM TROUBLESHOOTING

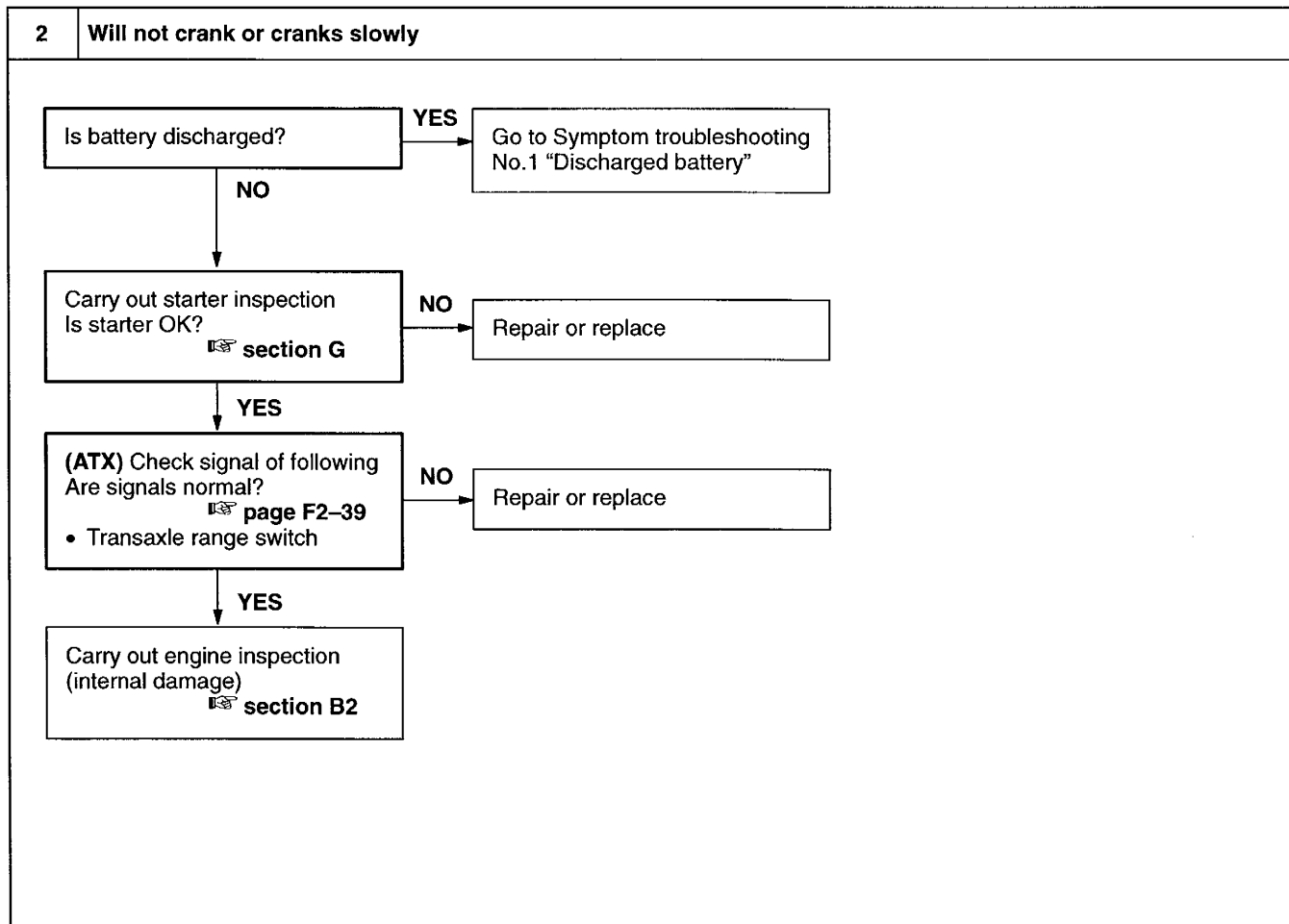
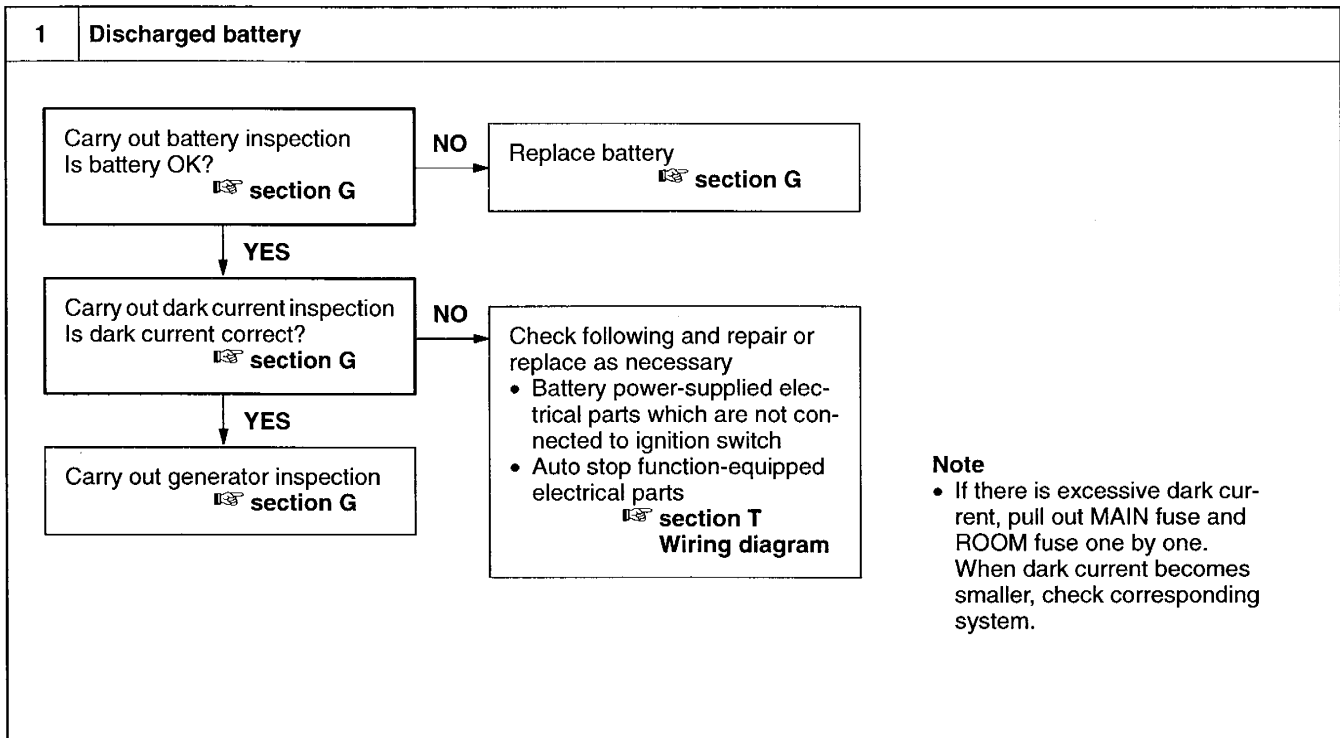

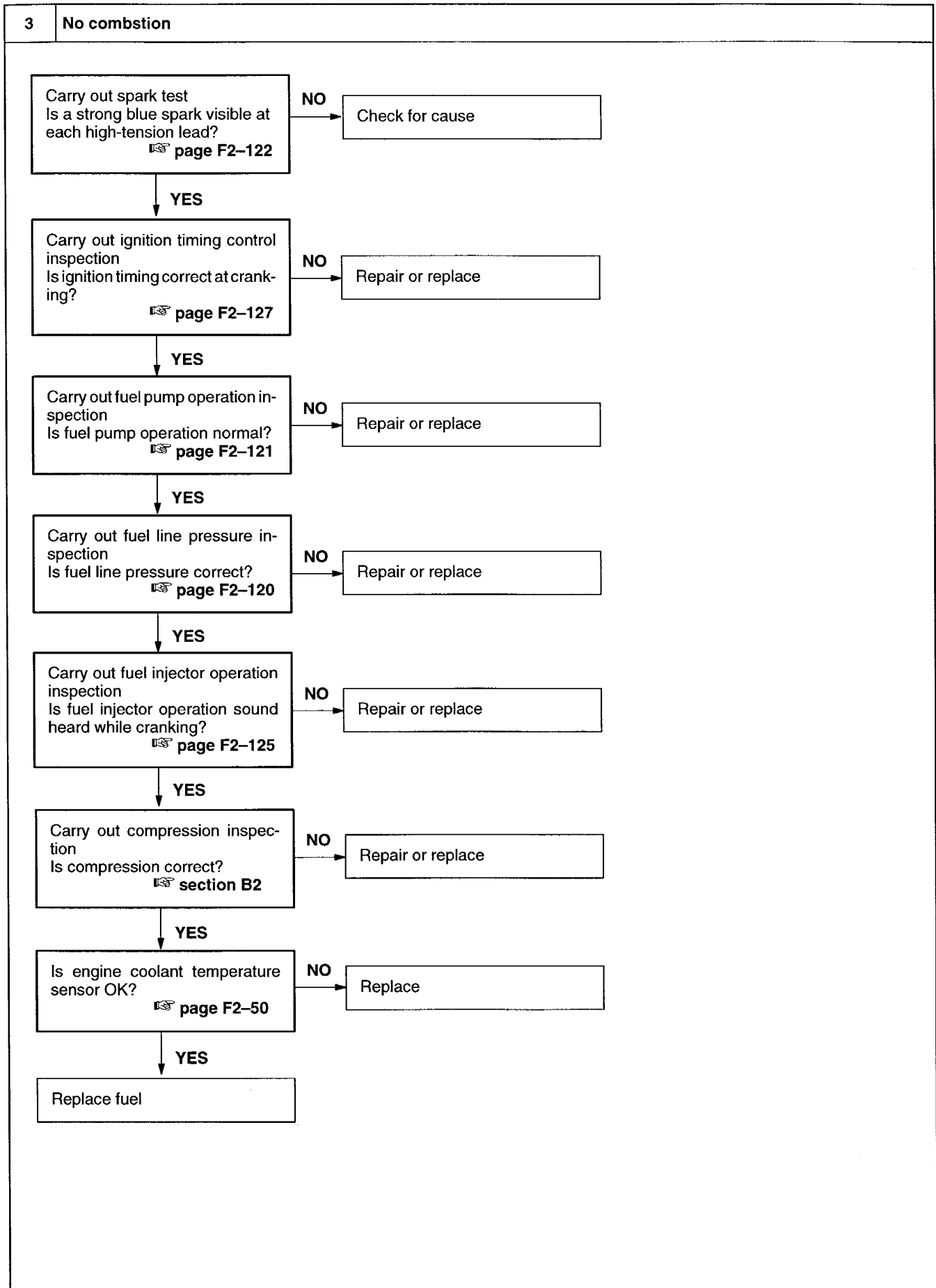

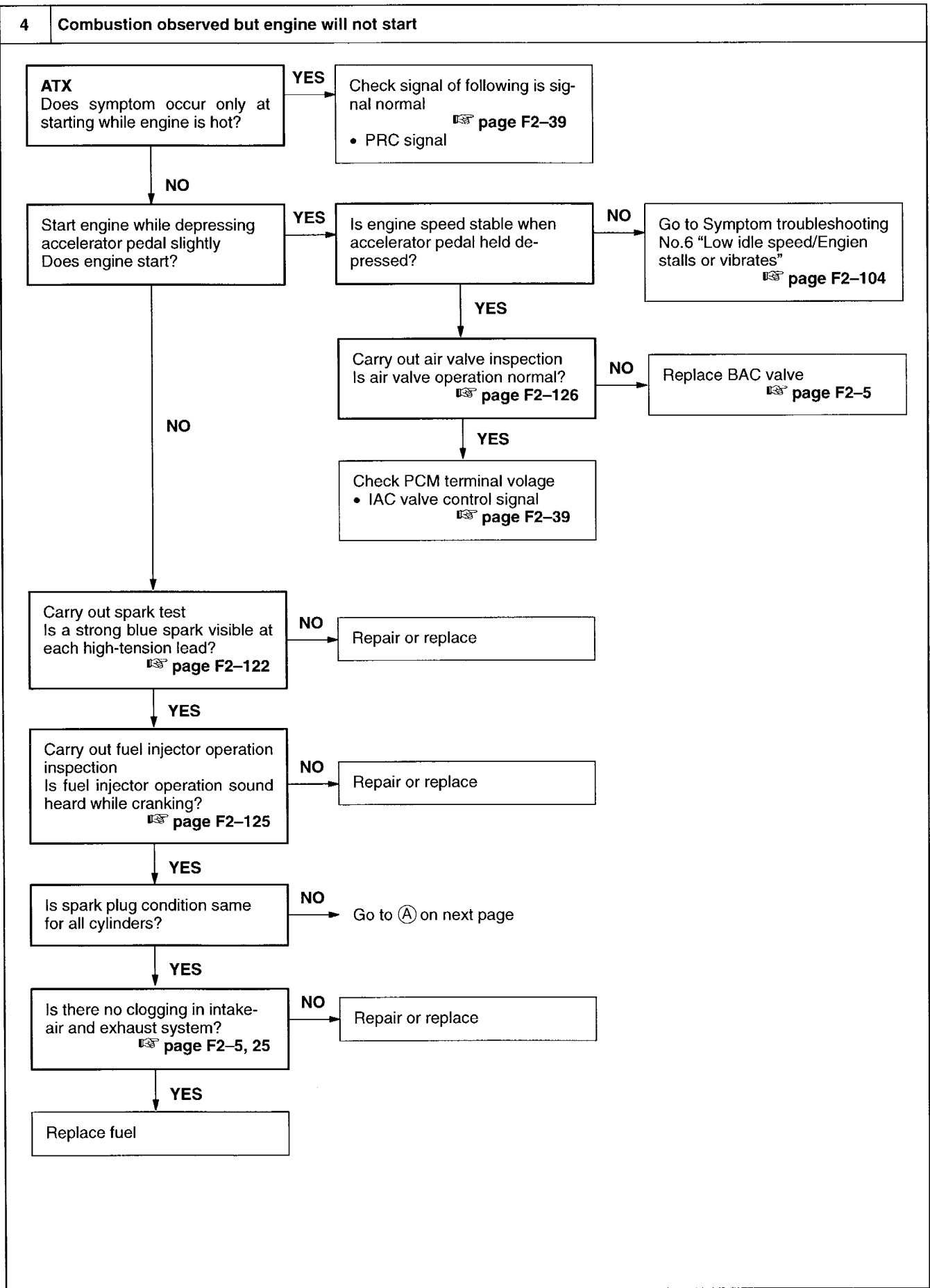

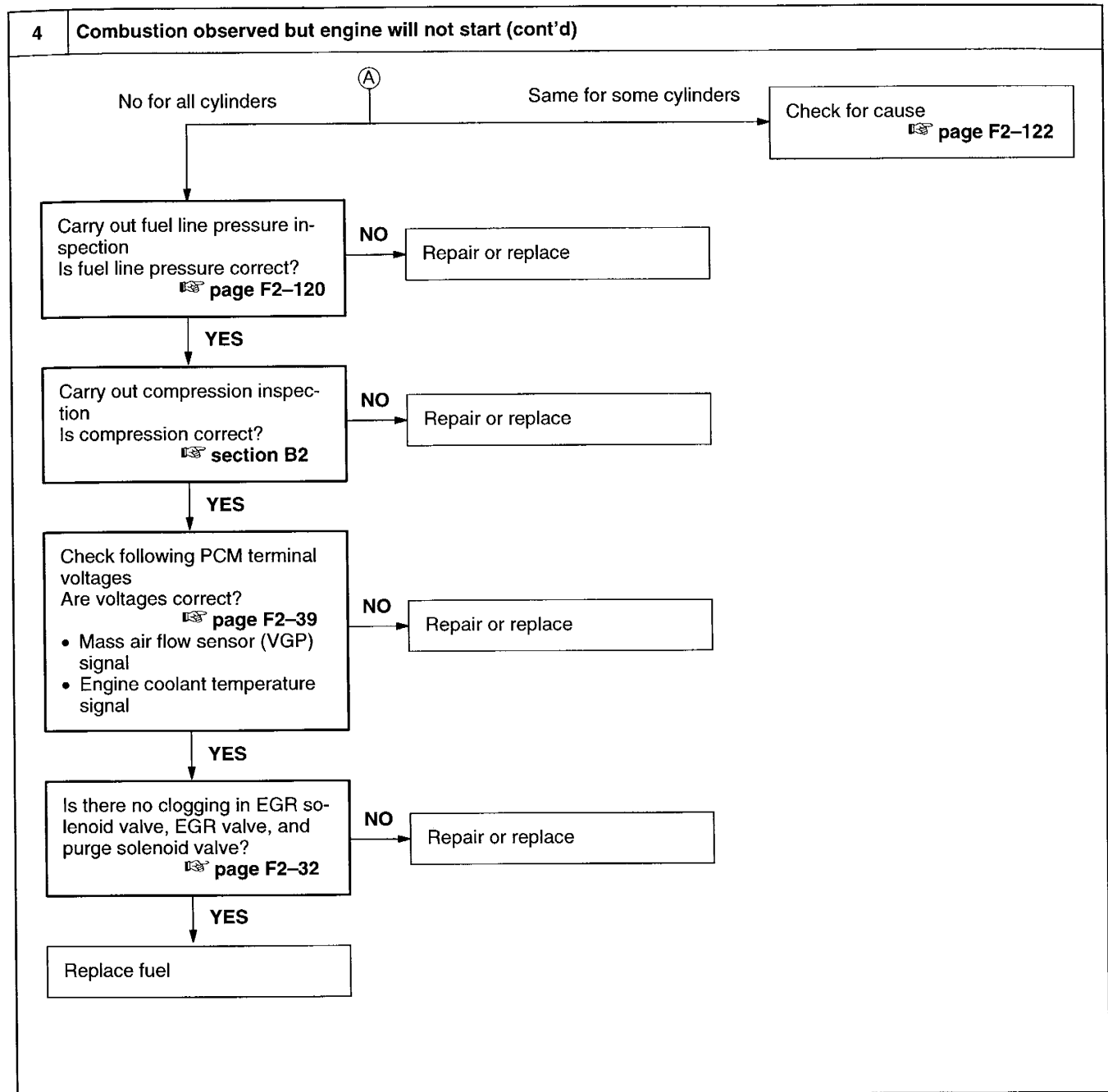

5 Cranks normally but hard to start

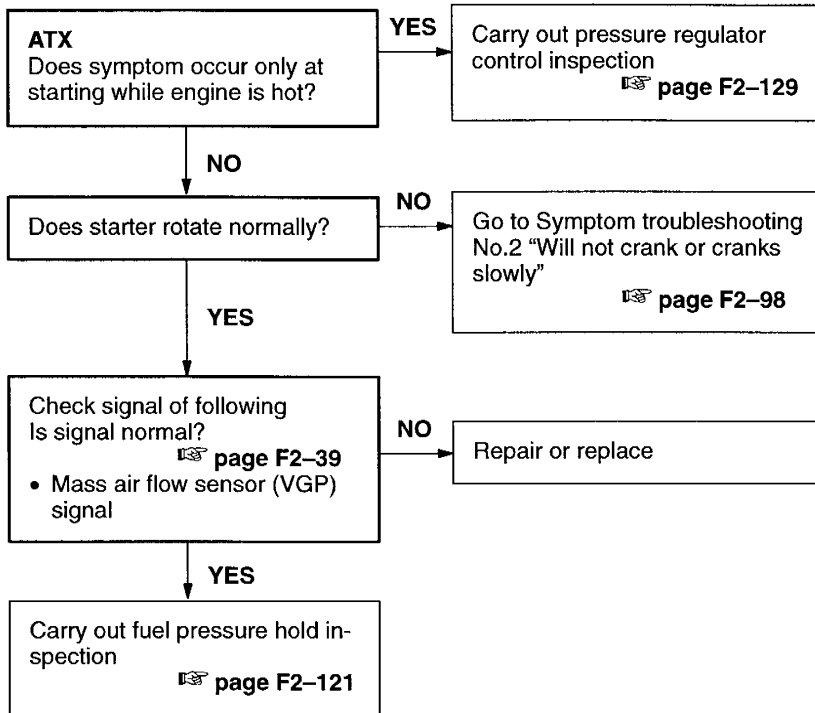

6 Low idle speed/Engine stalls or vibrates

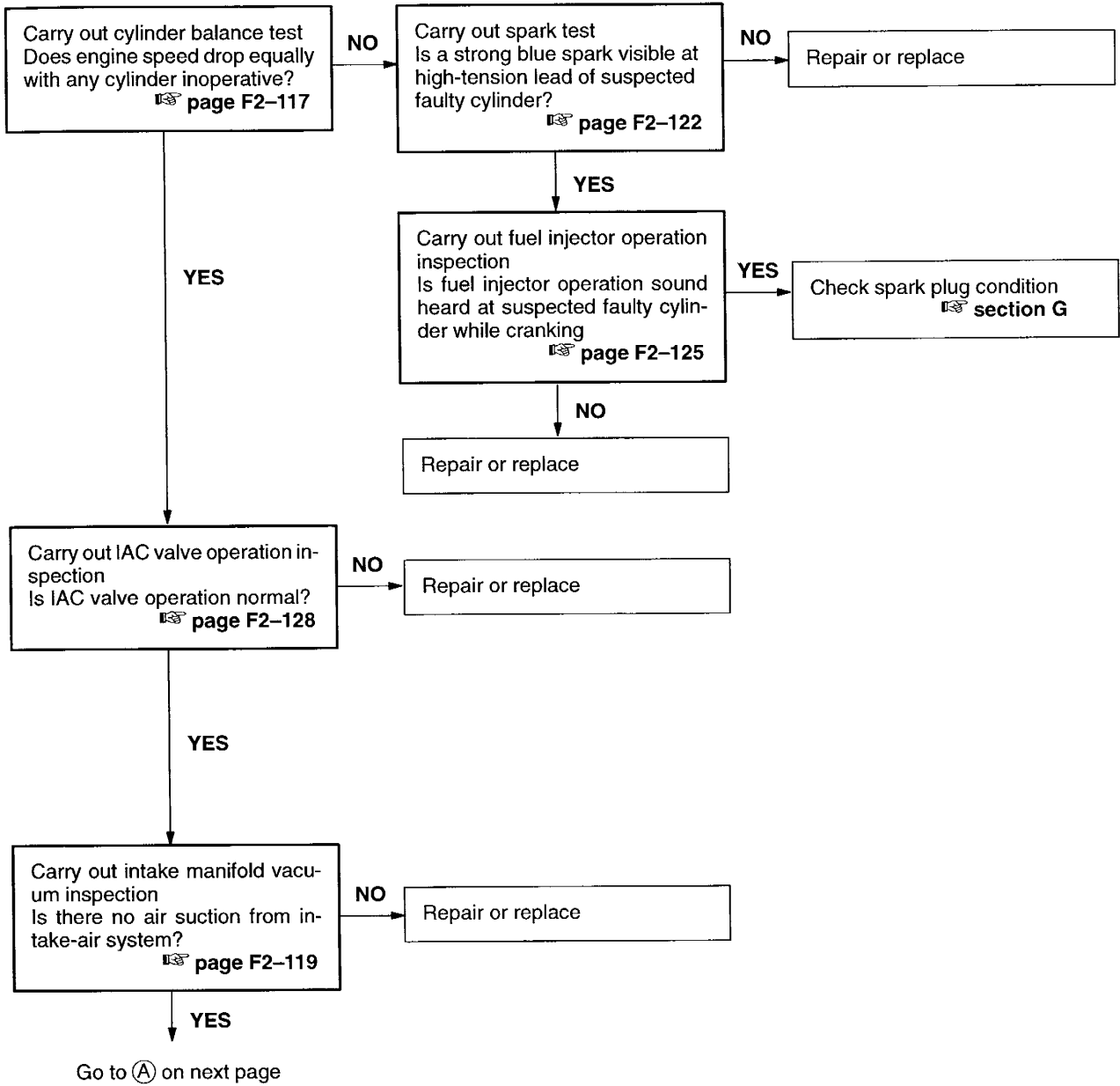

6 Low idle speed/Engine stalls or vibrates (cont'd)

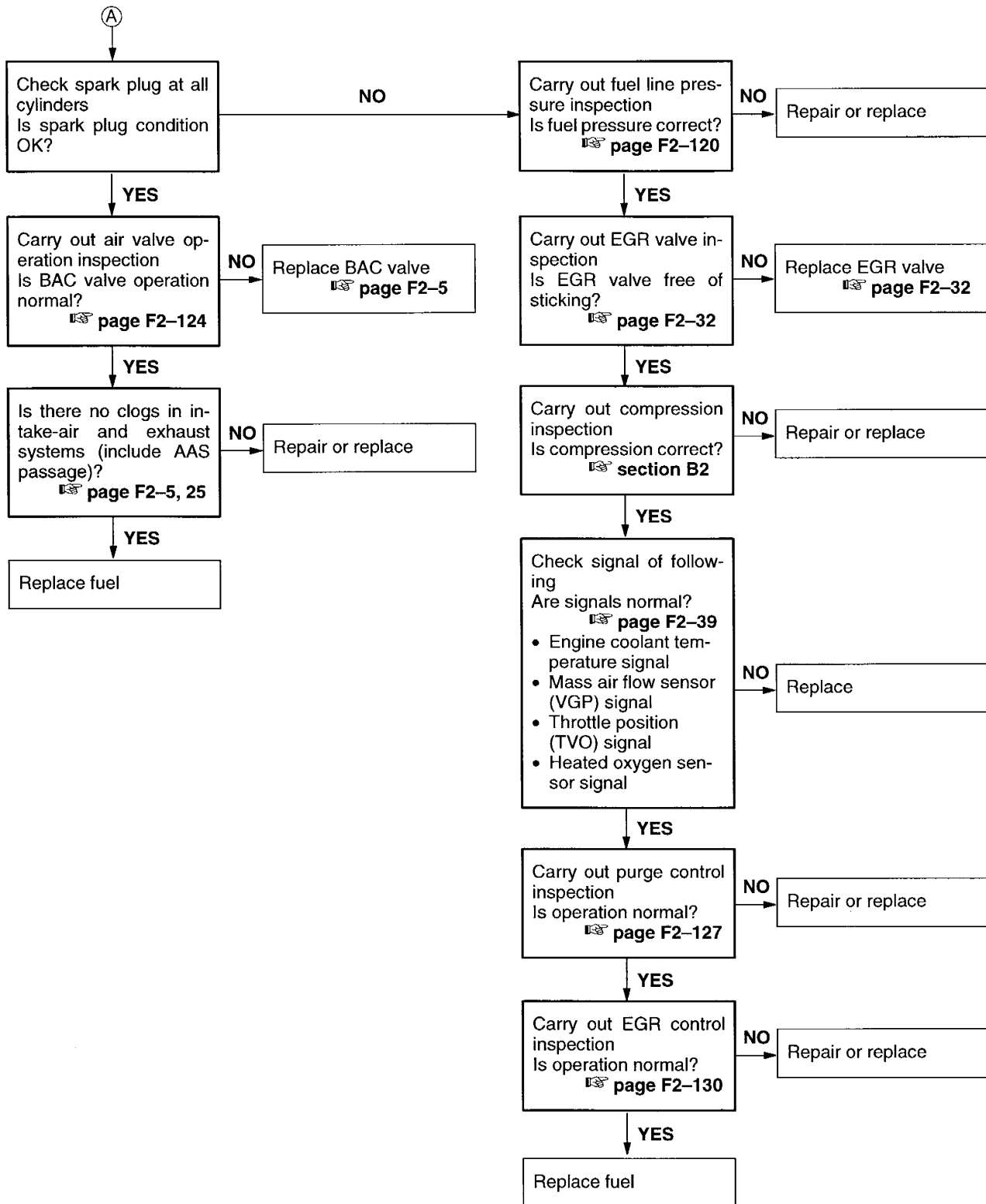

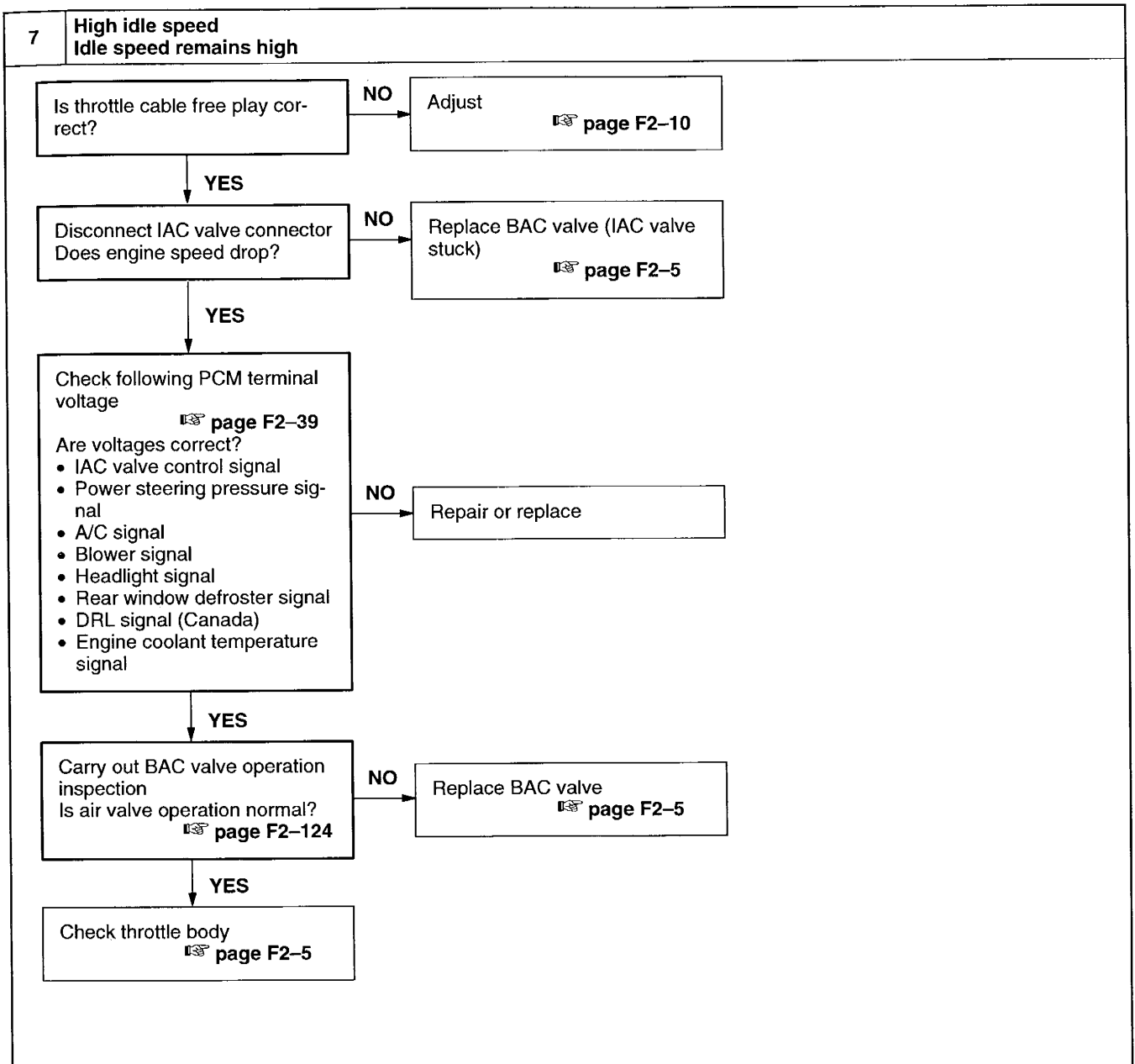

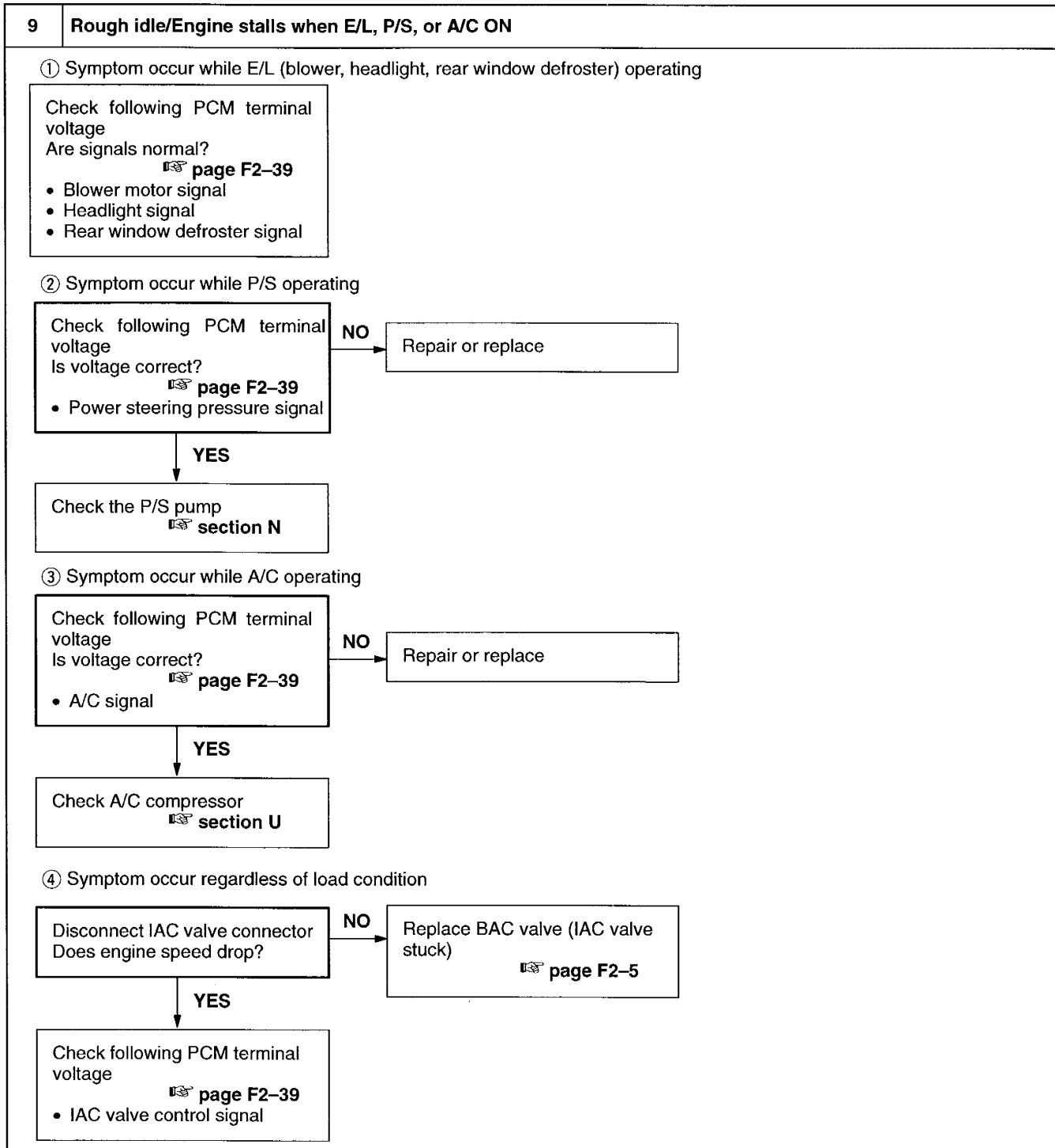
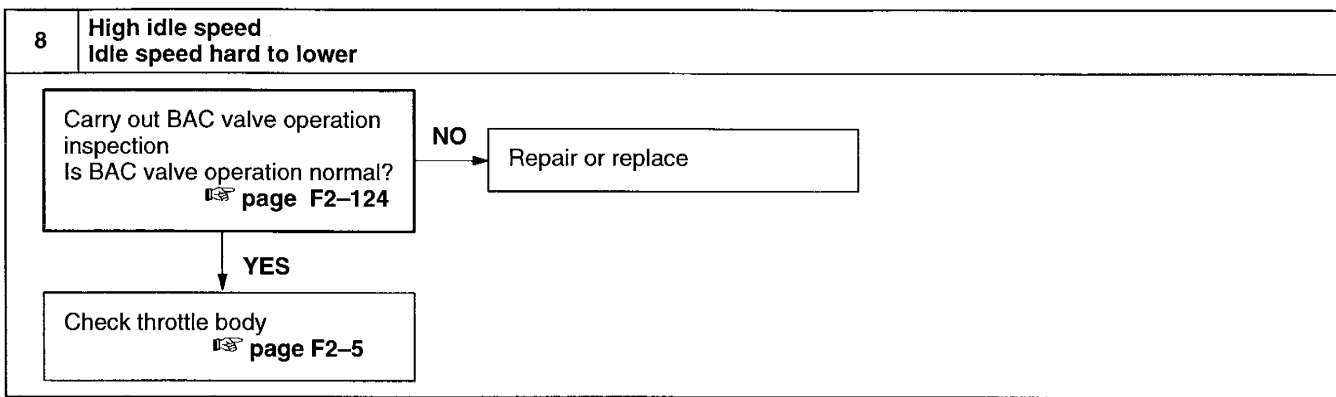

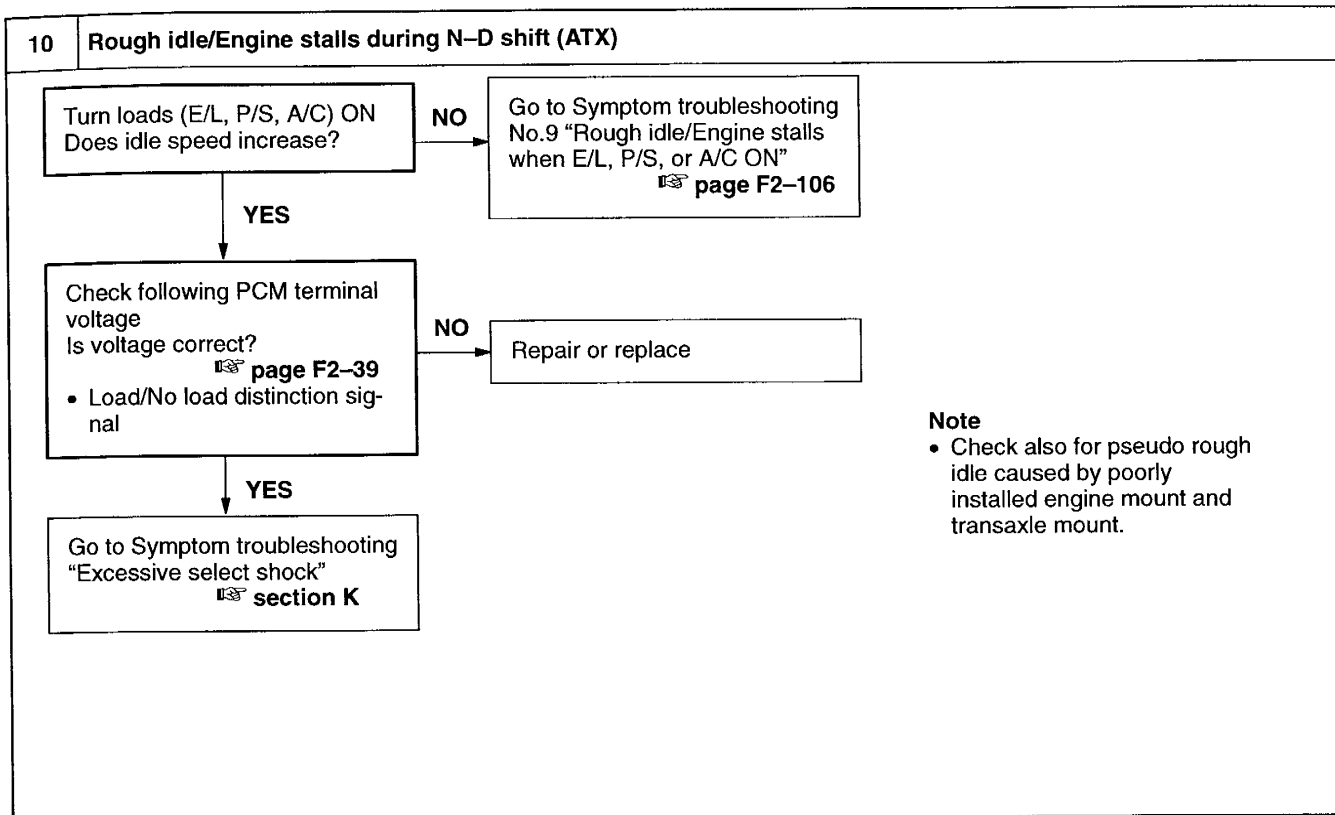

11 Engine stalls when vehicle about to run

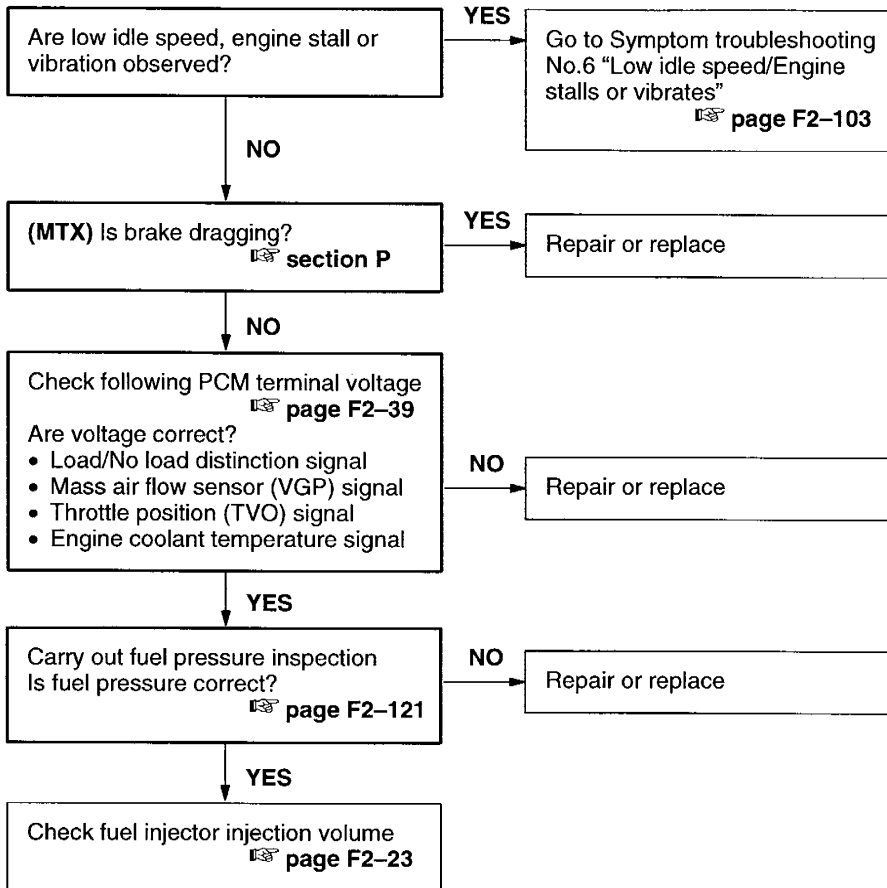

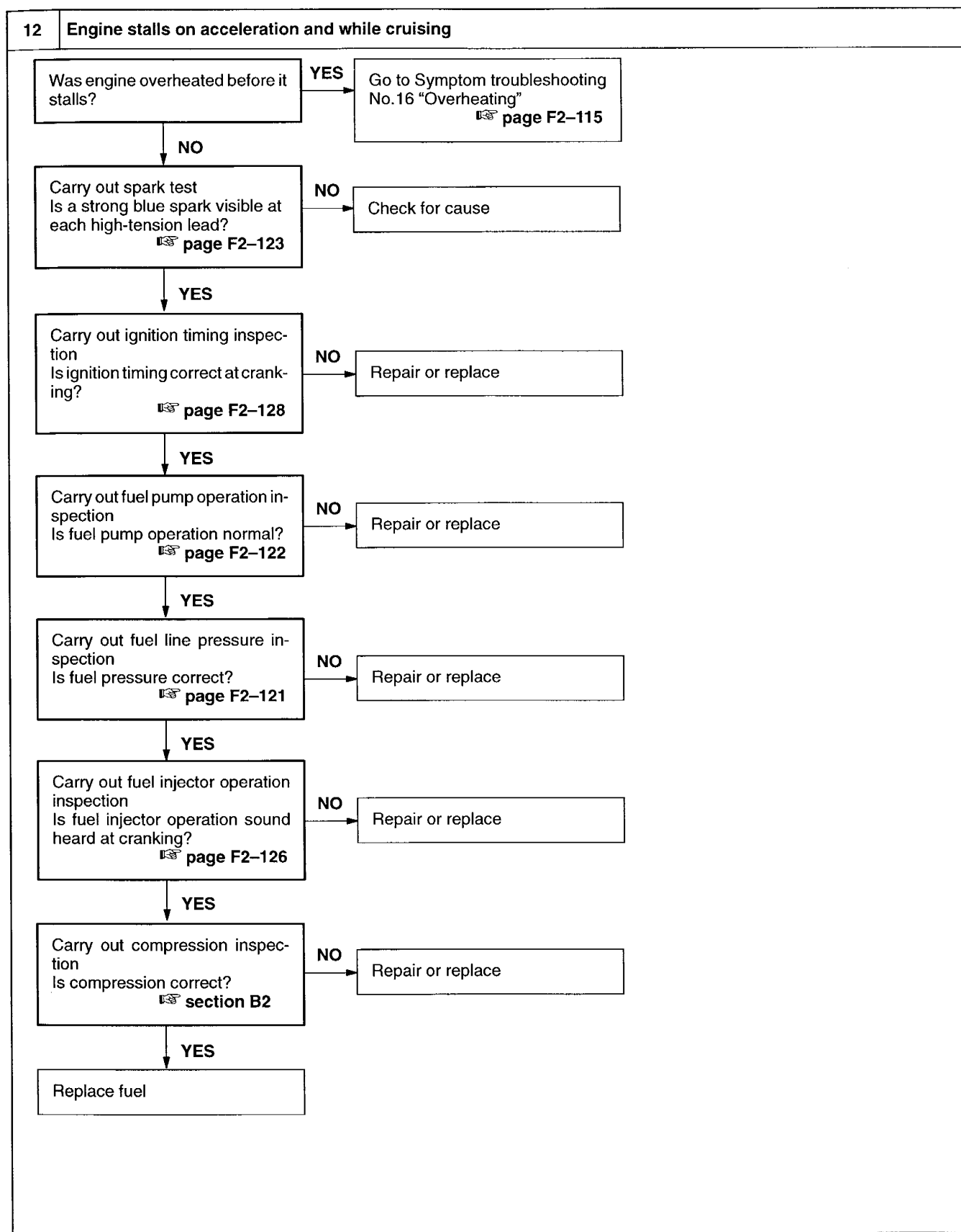

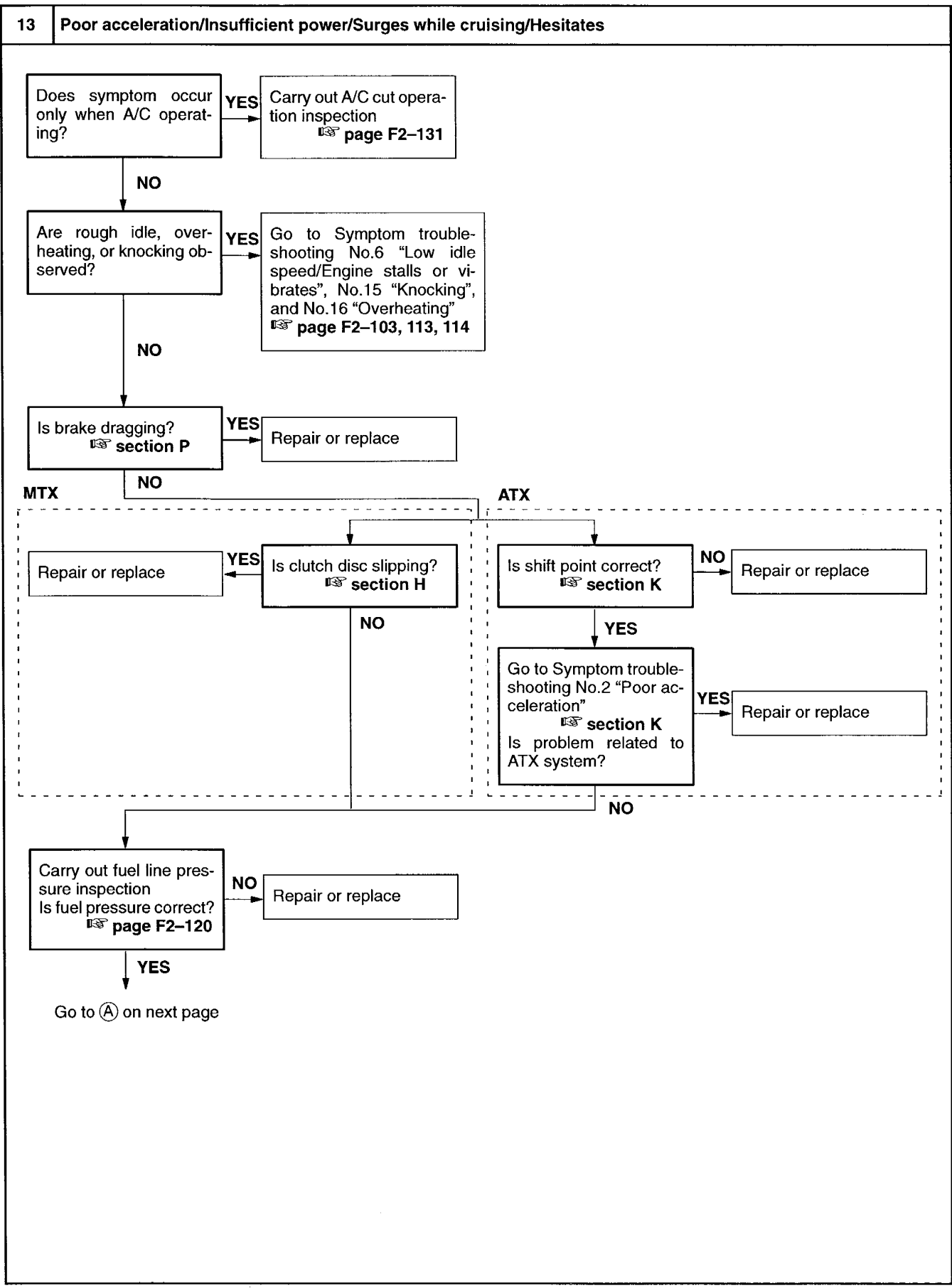

13 Poor acceleration/Insufficient power/Surges while cruising/Hesitates (Cont'd)

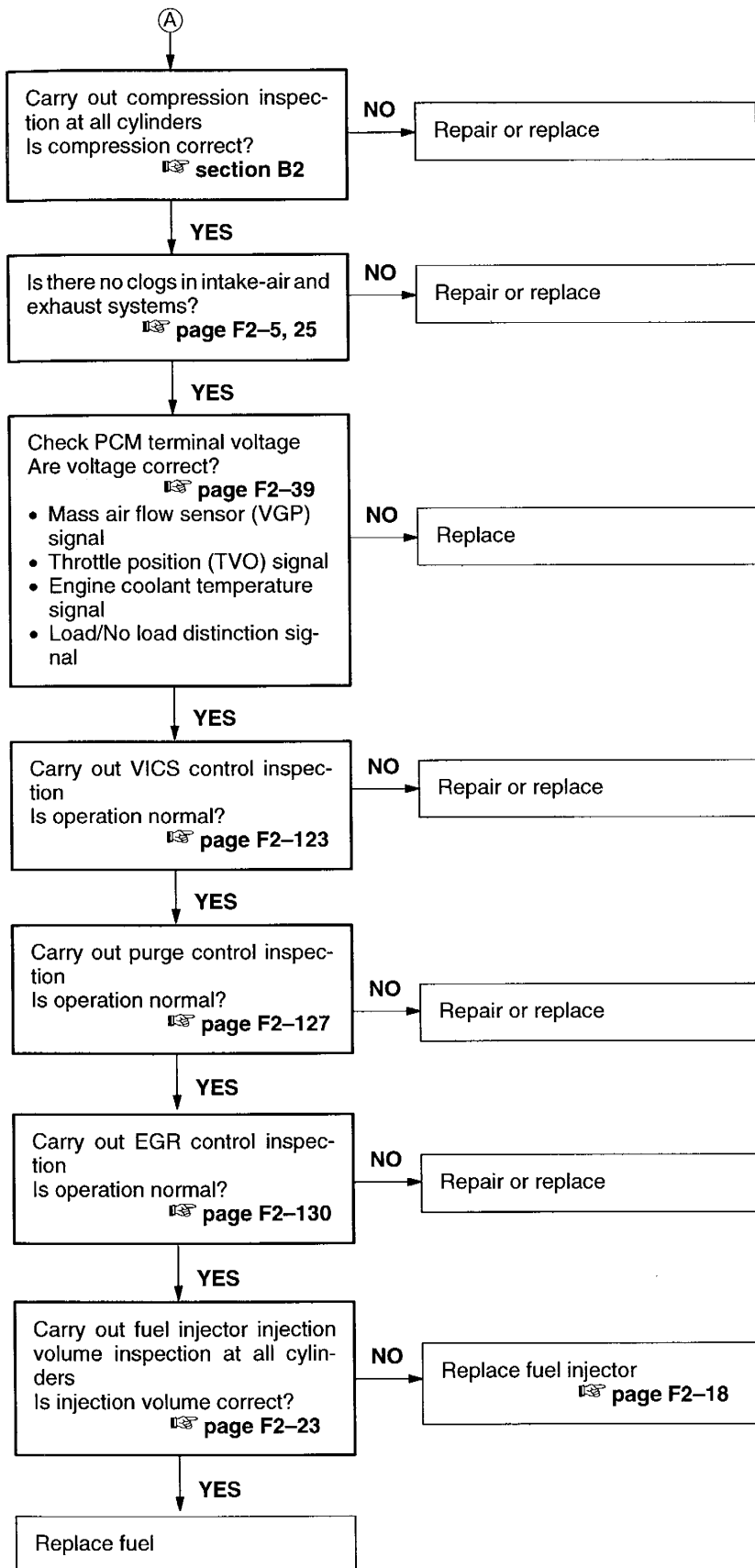
**Note**

- When symptom occur only when vehicle driving under heavy load condition, also check for leakage from ignition system (ignition coil, high-tension lead, spark plug)

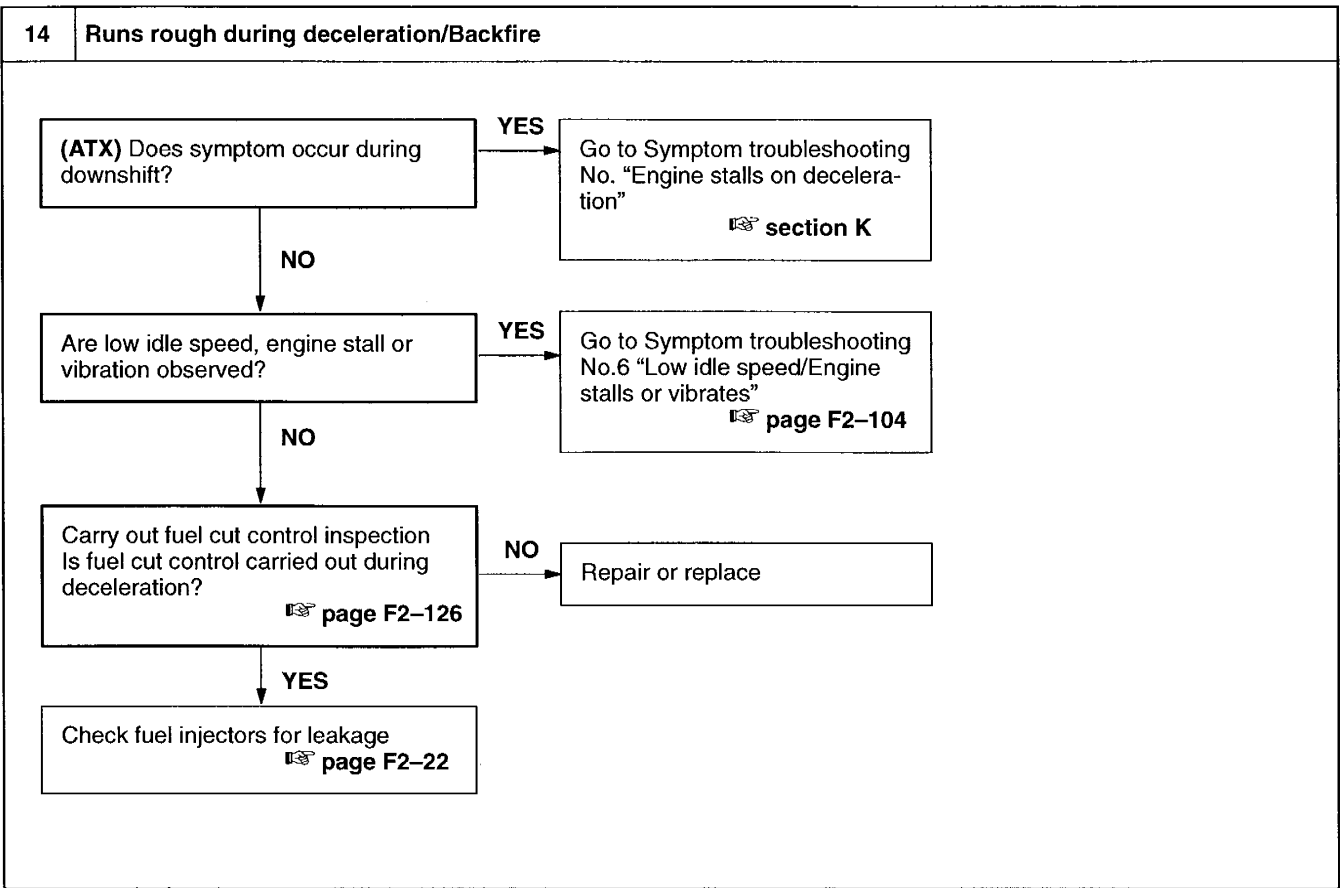

15 Knocking

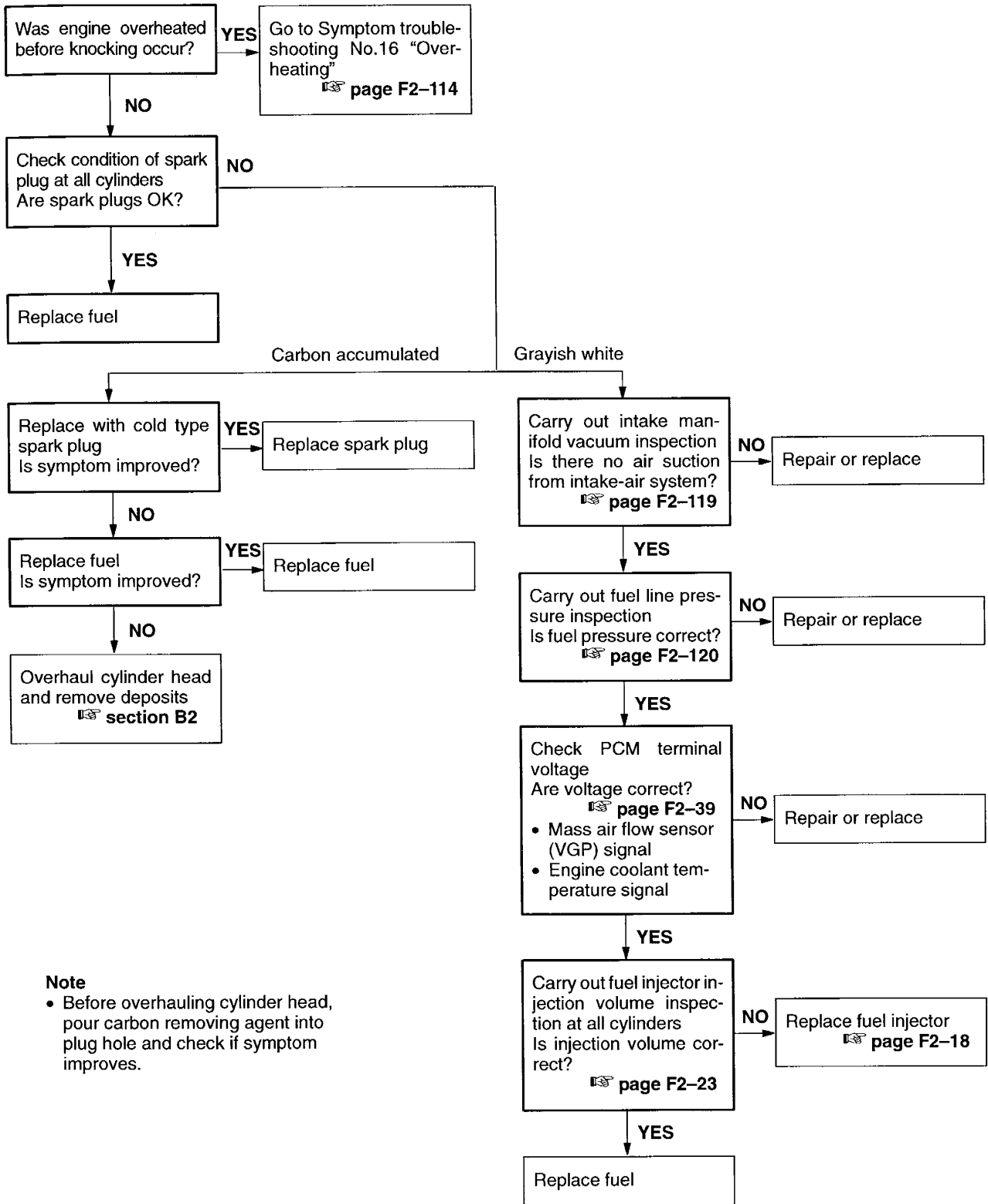

Note

- Before overhauling cylinder head, pour carbon removing agent into plug hole and check if symptom improves.

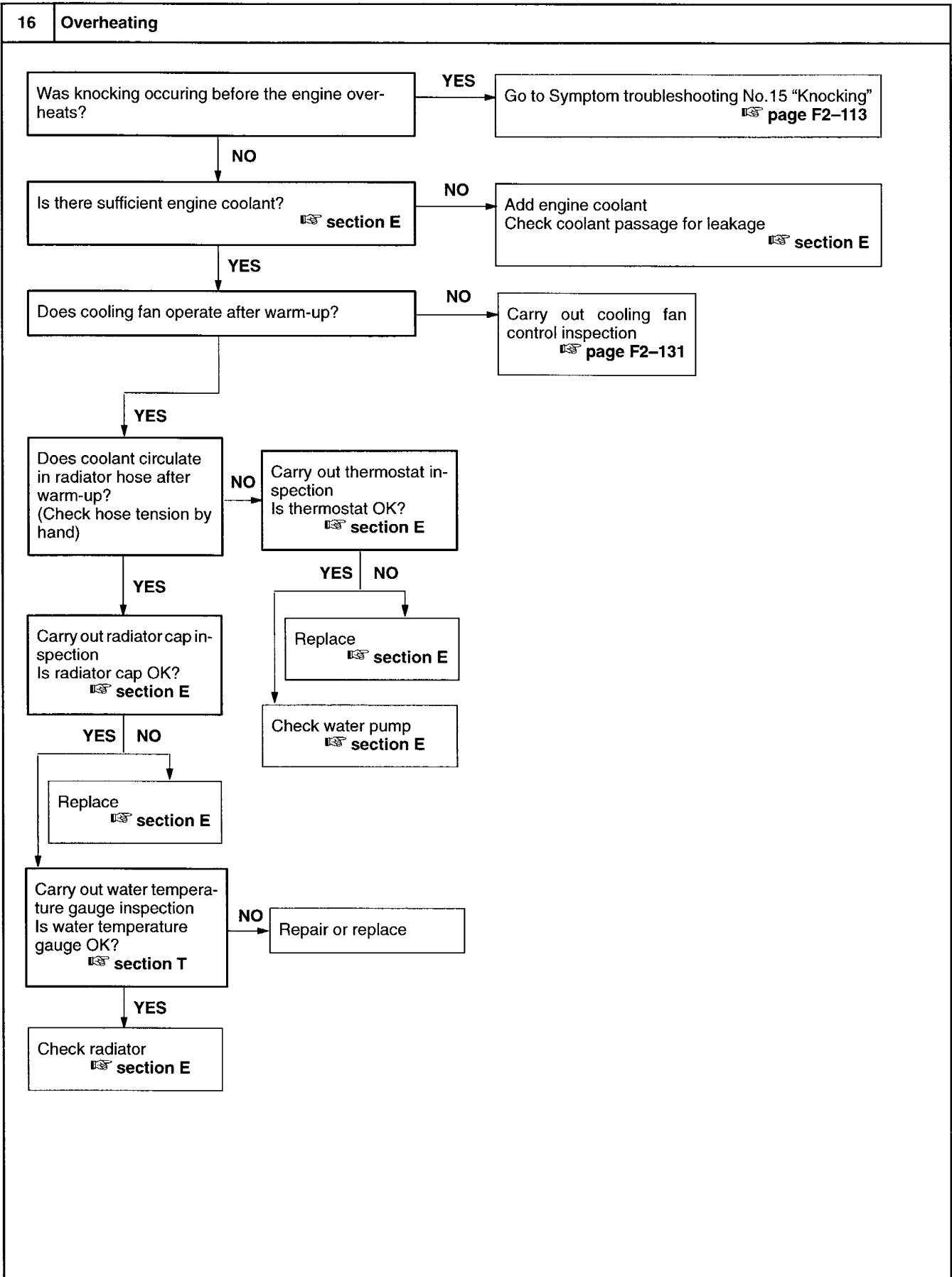

17 Poor fuel economy

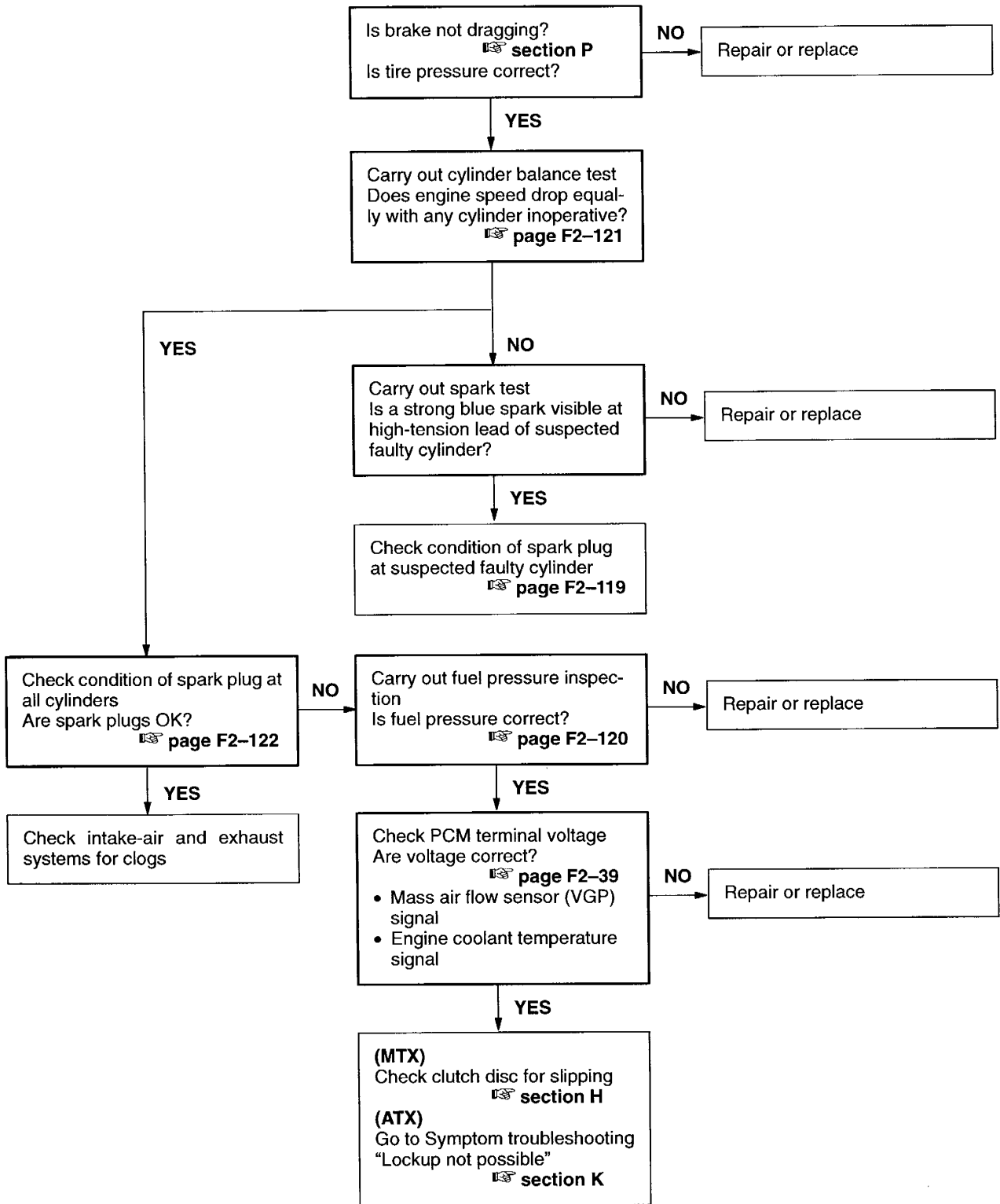

18 Fuel odor

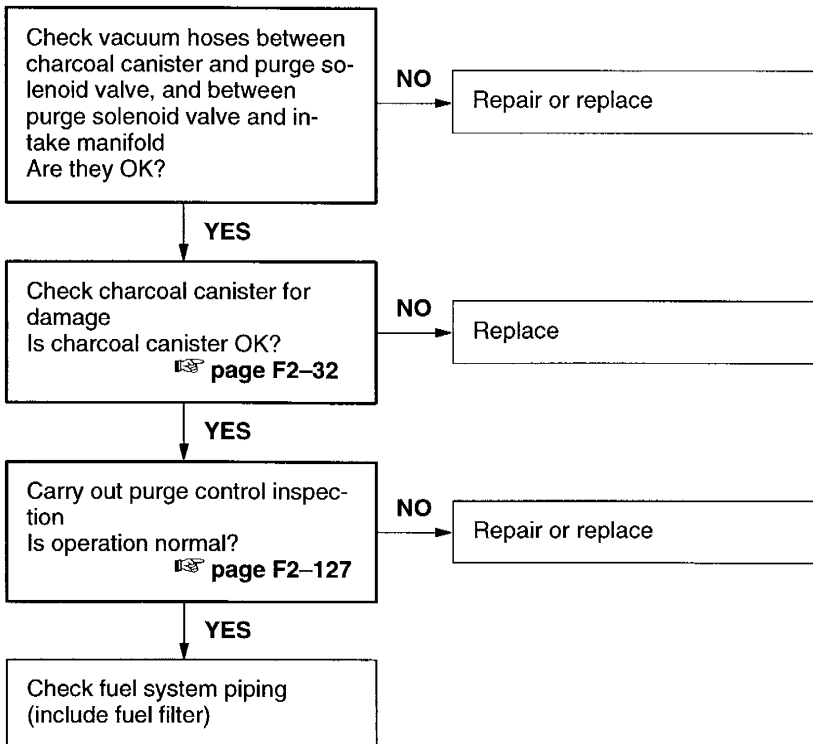

DIAGNOSTIC INSPECTION**Cylinder Balance Test****Purpose**

The purpose of the cylinder balance test is to find weak or non-contributing cylinders. In this test, the high-tension leads are disconnected one by one to shut off the ignition in each cylinder while the engine is running. The engine speed drop caused by this operation is measured and compared with each other, and the cylinder condition is judged. If all the engine speed decrease amounts are almost the same with any of the cylinder inoperative, there will be no weak or non-contributing cylinder. Engine speed different from others indicates that the corresponding cylinder is considered to be weak or non-contributing.

Warning

- High-voltage in ignition system can cause strong electrical shock. Avoid direct contact to the vehicle body during the cylinder balance test.
- High-voltage spark will negatively effect the engine control. To prevent this, ground the high-tension lead and keep away from sensors and harnesses.

Caution

- Cylinder balance test can overheat and damage the three way catalytic converter.

Note

- Diagnostic trouble codes (No. P0300, P0301, P0302, P0303, and P0304) will be stored in the PCM memory during the cylinder balance test. Carry out "After Repair Procedure" and erase these codes after this test. (Refer to page F2-54.)

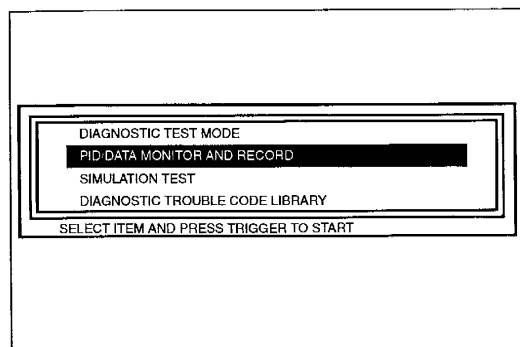
**Procedure**

1. Connect the **SSTs** (NGS) to the data link connector-2 and select the PID/DATA MONITOR AND RECORD function. (Refer to page F2-38.)
2. Select the "RPM" on the NGS display.
3. Start the engine and let it idle.
4. Disconnect each high-tension lead and measure the engine speed.
5. Compare the engine speed decrease amounts.

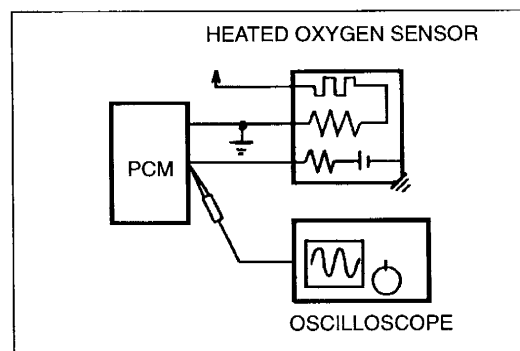
**Inspection using an oscilloscope**

1. Trouble detection by heated oxygen sensor output pulse.

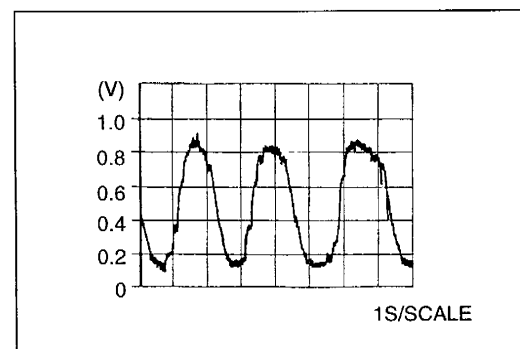

- (1) When normal Engine condition
No-load idling after warm-up

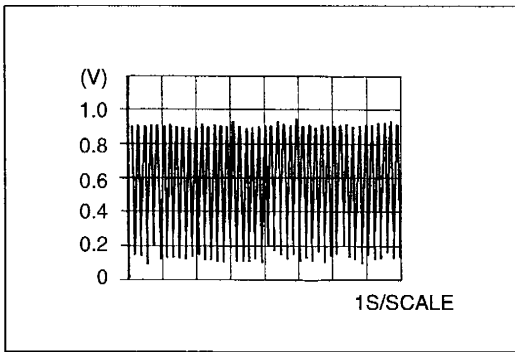

- (2) No injection in one cylinder
 Engine condition
 No-load idling after warm-up
 Pulse detected
 Pulse cycle extremely short

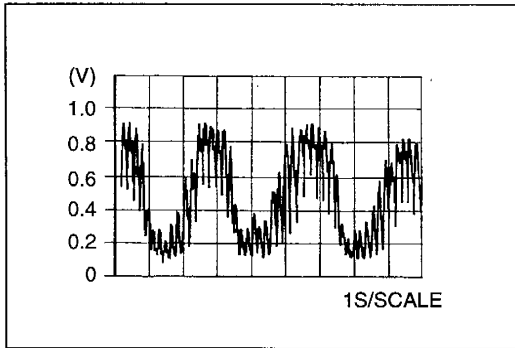

- (3) No ignition in one cylinder
 Engine condition
 No-load idling after warm-up
 Pulse detected
 Pulse cycle longer than normal pulse
 Rich spike caused by unburnt gas in misfiring cylinder observed

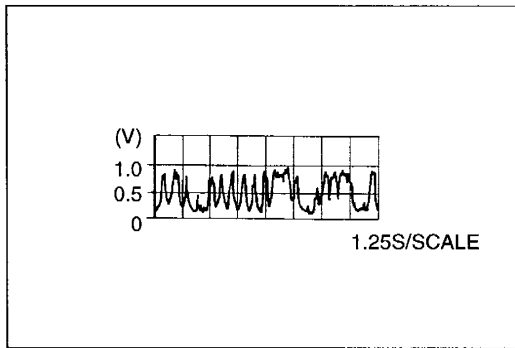

- (4) Exhaust gas flown in cylinder
 Engine condition
 No-load idling after warm-up
 Pulse detected
 Pulse width and cycle irregular

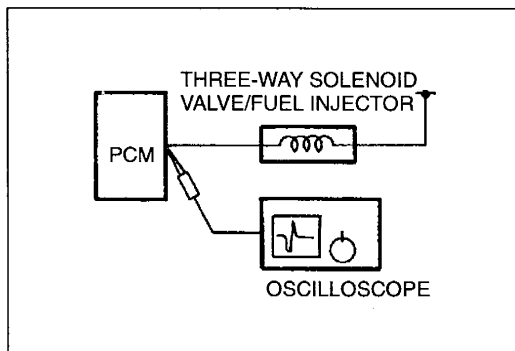

2. Plunger sticking detection using an oscilloscope.

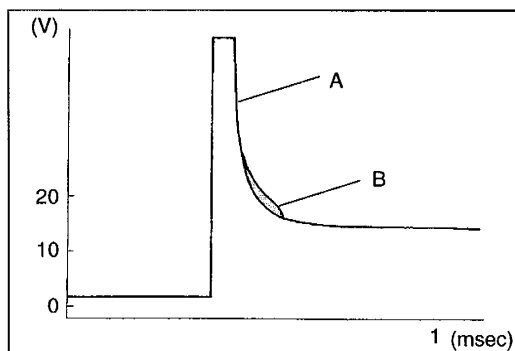

- (1) When normal
 Counter electromotive voltage A, generated when the three-way solenoid valve or the fuel injector is turned off from on, shows irregular convergence because induced electromotive voltage B, generated by the plunger return operation, is added to it.

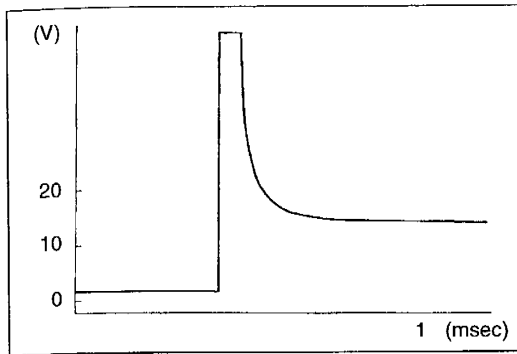

- (2) When plunger stuck
When the plunger is stuck, pulse convergence is smooth because no induced electromotive voltage B is generated.

Trouble judgement by spark plug conditions

Condition	Possible cause	page
Carbon accumulated on some spark plugs only	Fuel leakage from fuel injector Damaged spark plug (Cracked insulator) Low compression	☞ page F2-22 ☞ section G ☞ section B2
Some spark plugs wet	Excessive fuel injection from fuel injector Damaged spark plug Low compression	☞ page F2-23 ☞ section G ☞ section B2
Some spark plugs look grayish white	Insufficient fuel injection from fuel injector	☞ page F2-23

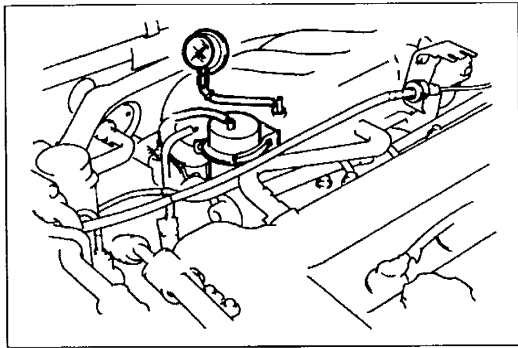

SYSTEM INSPECTION

Intake Manifold Vacuum Inspection

1. Verify that the intake-air system hoses are fitted securely.
2. Disconnect the vacuum hose from the pressure regulator and connect to vacuum gauge as shown.
3. Start the engine and let it idle.
4. Measure the intake manifold vacuum by using a vacuum gauge.

Vacuum: More than 60 kPa { 450 mmHg , 18 inHg }

5. If not as specified, check following
 - Air suction at:
 - Throttle body installation point
 - Intake manifold installation point
 - PCV valve installation point
 - Accelerator cable free play (Refer to page F2-10.)
 - Engine compression (Refer to section B2.)

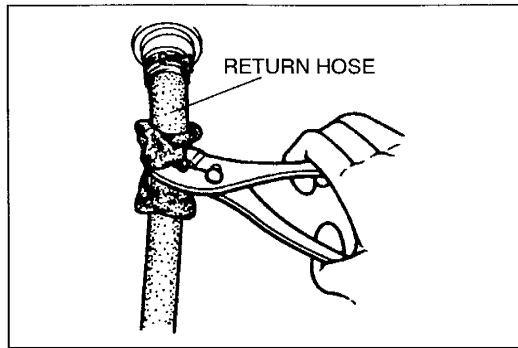
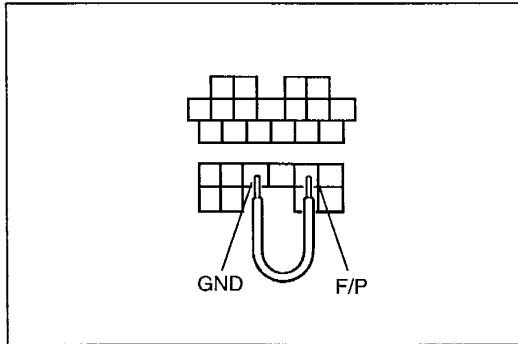
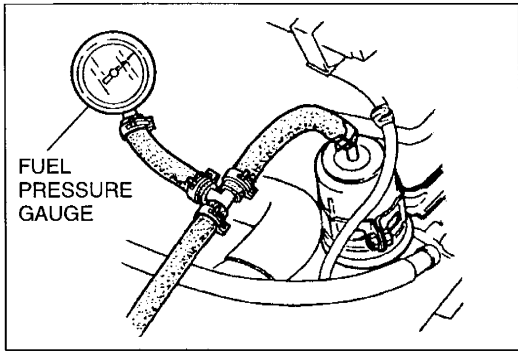

Fuel Line Pressure Inspection

Warning

- Fuel line spills and leaks are dangerous. Fuel can ignite and cause serious injuries or death and damage. Fuel can also irritate skin and eyes. To prevent this, always complete the “Fuel Line Safety Procedures” on page F2-11.

1. Disconnect the negative battery cable.
2. Connect a fuel pressure gauge between the fuel filter (high pressure side) and fuel distributor.
3. Connect the negative battery cable.
4. Connect data link connector terminals F/P and GND by using a jumper wire.
5. Turn the ignition switch to ON and measure the fuel line pressure.

Specification:

280—310 kPa { 2.8—3.2 kgf/cm² , 40—45 psi }

6. Turn off the ignition switch and disconnect the jumper wire.
7. If the pressure is higher than specified, check the fuel pump maximum pressure. (Refer to page F2-21.)
If normal, check the pressure regulator, or fuel return hose is clogged.
8. If the pressure is lower than specified, measure the fuel line pressure with pinching the return hose.
 - If the fuel line pressure quickly increases, check the pressure regulator. (Refer to page F2-23, 24.)
 - If the fuel line pressure gradually increases, check the fuel pump maximum pressure. (Refer to page F2-21.)
9. If the pressure is normal, check the clogging between fuel pump and pressure regulator.

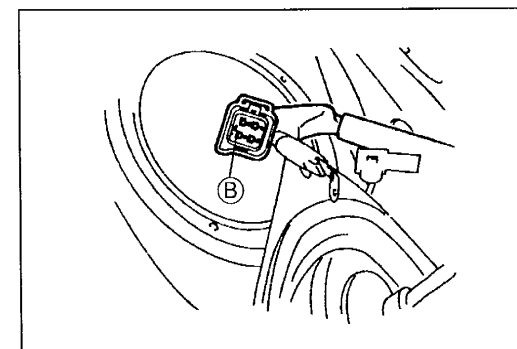
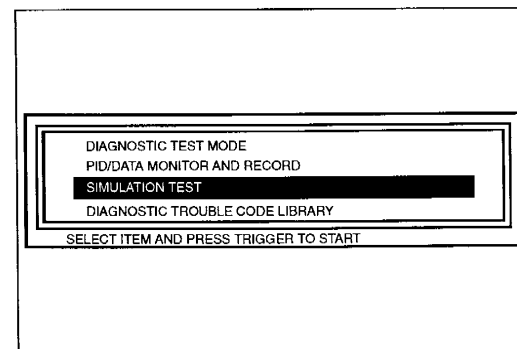
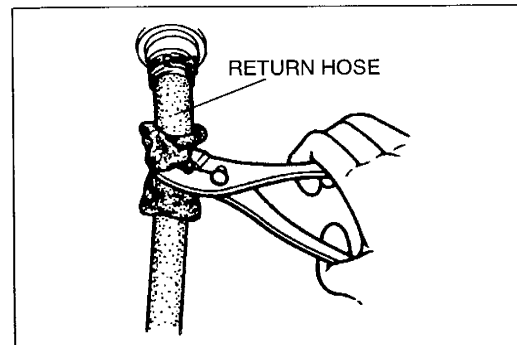
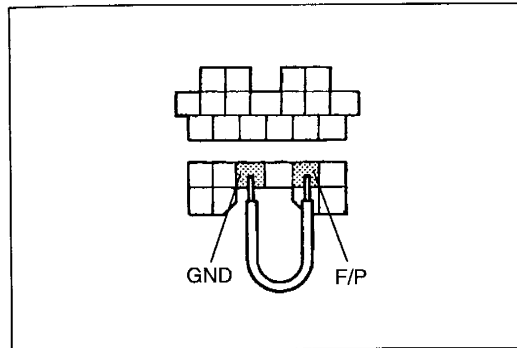
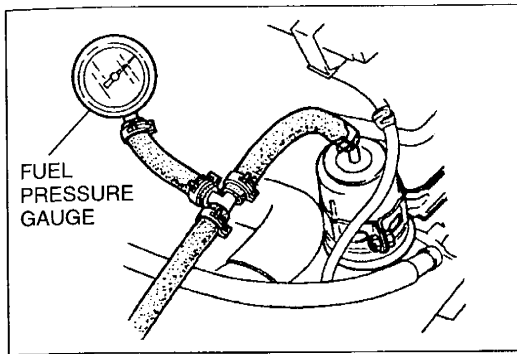

Fuel Pressure Hold Inspection

Warning

- Fuel line spills and leaks are dangerous. Fuel can ignite and cause serious injuries or death and damage. Fuel can also irritate skin and eyes. To prevent this, always complete the “Fuel Line Safety Procedures” on page F2-11.

1. Disconnect the negative battery cable.
2. Connect a fuel pressure gauge between the fuel filter (high pressure side) and fuel distributor.
3. Connect the negative battery cable.
4. Connect data link connector terminals F/P and GND by using a jumper wire.
5. Turn the ignition switch to ON for approx. 10 sec. to operate the fuel pump.
6. Turn off the ignition switch. Wait for 5 min., and measure the fuel pressure.

Specification:

More than 150 kPa { 1.5 kgf/cm² , 21 psi }

7. Disconnect the jumper wire.
8. If the pressure is lower than specified, measure the fuel line pressure with pinching the return hose.
 - If the fuel line pressure holds, replace the pressure regulator. (Refer to page F2-18.)
 - If the fuel line pressure dose not hold, check the fuel pump fuel hold pressure. (Refer to page F2-21.) If the fuel pump fuel hold pressure is normal, check the fuel leaks from fuel line and fuel injector.

Fuel Pump Operation Inspection

1. Connect the **SSTs** (NGS) to the data link connector-2. (Refer to page F2-38.)
2. Remove the fuel filler cap.
3. Turn the ignition switch to ON.
4. Select the SIMULATION TEST function on the NGS display.
5. Turn the fuel pump relay from OFF to ON by using the “FP RLY”. Operate the fuel pump relay and check if operation sound of the fuel pump is heard.
 - (1) If the operation sound is heard, do as follows.
 - I. Measure the voltage at terminal B of the fuel pump connector (harness side).
Voltage: Battery positive voltage (Ignition switch: ON)
 - II. If the voltage is correct, check the following.
 - Continuity of the fuel pump (Refer to page F2-21.)
 - III. If the voltage is not correct, check the following.
 - Wiring harnesses and connectors (Fuel pump relay — Fuel pump)
 - (2) If the operation sound is not heard, check the following.
 - Fuel pump relay (Refer to page F2-24.)
 - Wiring harnesses and connectors (Main relay — Fuel pump relay — PCM)

Spark Test

1. Remove the rear seat cushion. (Refer to section S.)
2. Disconnect the fuel pump connector. (Refer to page F2-16.)
3. Verify that each high-tension lead and connector is connected properly.
4. Inspect the ignition system in the following procedure.

Warning

- **High voltage in the ignition system can cause strong electrical shock. Avoid direct contact to the vehicle body during the following spark test.**

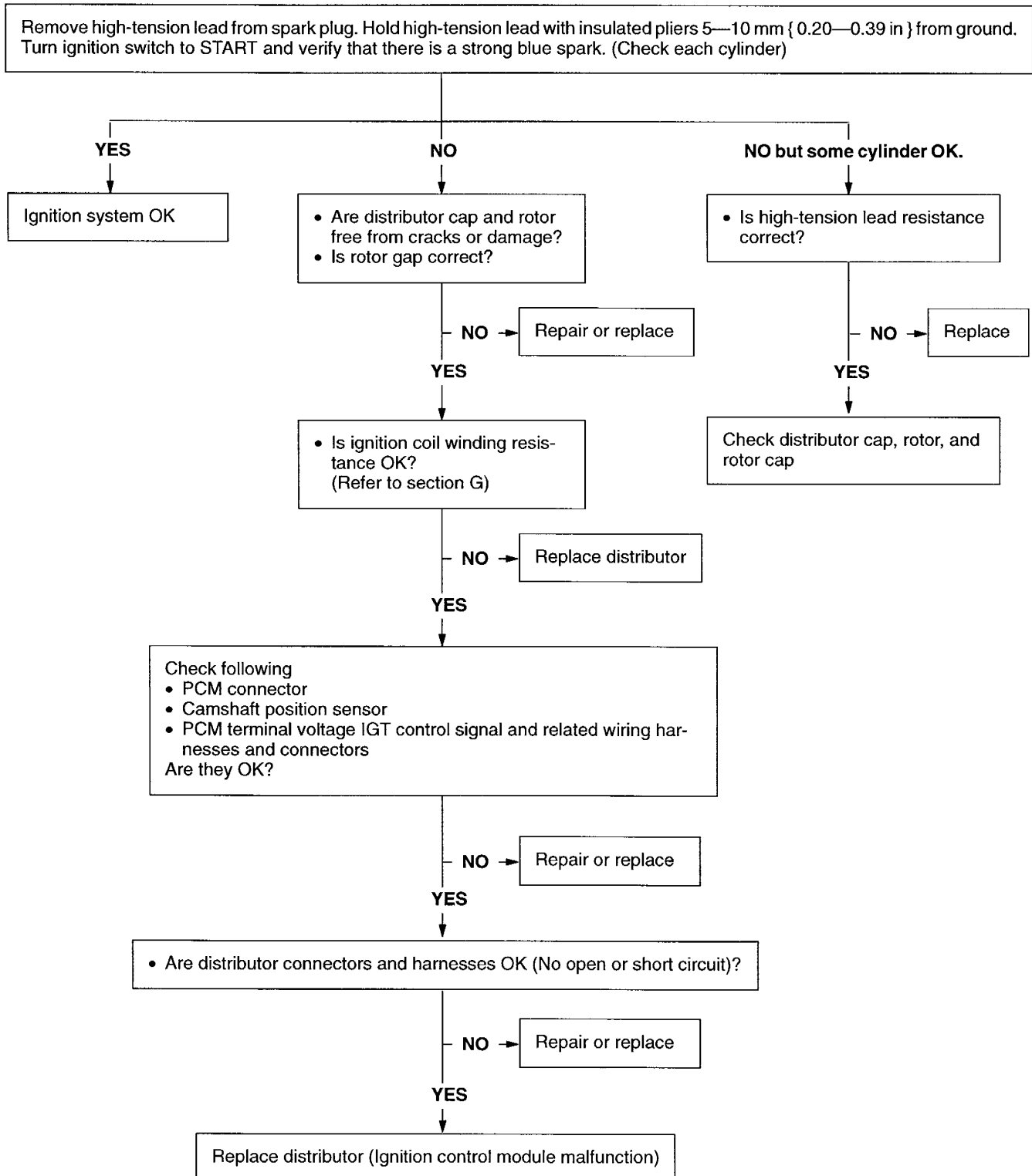

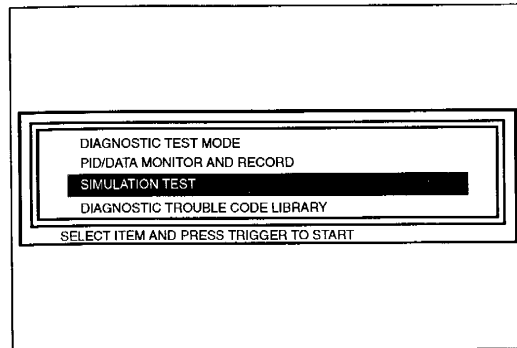
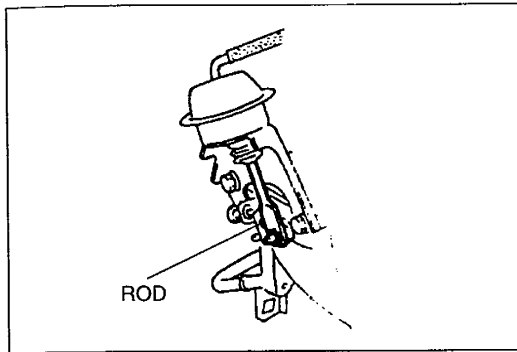

VICS Operation Inspection

1. Start the engine.
2. Verify that the rod of the VICS shutter valve actuator is pulled.
3. If the rod is not pulled, do as follows.
 - (1) Stop the engine.
 - (2) Connect the **SSTs** (NGS) to the data link connector-2. (Refer to page F2-38.)
 - (3) Verify that diagnostic trouble code No. P1523 is not displayed. If code No. P1523 is shown, carry out trouble shooting of the code No. P1523. (Refer to page F2-89.)
 - (4) If diagnostic trouble codes are not shown, do as follows.
 - I. Start the engine and run it at idle.
 - II. Select the **SIMULATION TEST** function on the NGS display.
 - III. Turn the VICS solenoid valve from ON to OFF by using the "VICSV" and check if operation sound of the solenoid valve is heard.
 - IV. If the operation sound is heard, check the following.
 - Loose or damaged vacuum hose and vacuum chamber
 - Shutter valve actuator (Refer to page F2-8.)
 - V. If the operation sound is not heard, check the following.
 - VICS solenoid valve (Refer to page F2-9.)
4. Check the rod operation under the following conditions.

Rod operation

Engine speed (rpm)	4900	
Shutter valve actuator	Not operate	Operate

5. If the rod operation is not as specified, do as follows.
 - (1) Stop the engine.
 - (2) Connect the **SSTs** (NGS) to the data link connector-2. (Refer to page F2-38.)
 - (3) Verify that diagnostic trouble code No. P1523 is not displayed. If code No. P1523 is shown, carry out troubleshooting of the code No. P1523. (Refer to page F2-89.)
 - (4) If diagnostic trouble codes are not shown, do as follows.
 - I. Start the engine and run it at idle.
 - II. Select the **SIMULATION TEST** function on the NGS display.
 - III. Turn the VICS solenoid valve from ON to OFF by using the "VICSV" and check if operation sound of the solenoid valve is heard.
 - IV. If the operation sound is heard, check the following.
 - Shutter valve actuator (Refer to page F2-8.)
 - V. If the operation sound is not heard, check the following.
 - VICS solenoid valve (Refer to page F2-9.)

Note

- The shutter valve actuator rod extends for five seconds after the engine is started.

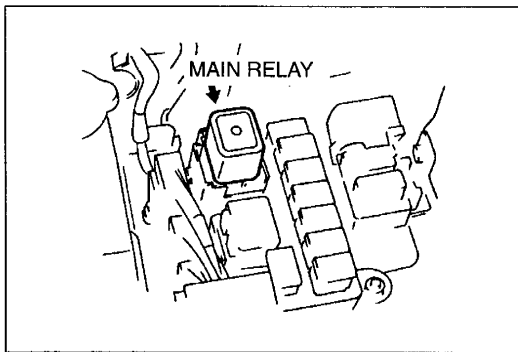

Main Relay Operation Inspection

1. Verify that the main relay clicks when the ignition switch is turned to ON and OFF.
2. If there is no operation sound, inspect the following.
 - Main relay (Refer to page F2-53.)
 - Harness and connector between ignition switch and main relay.

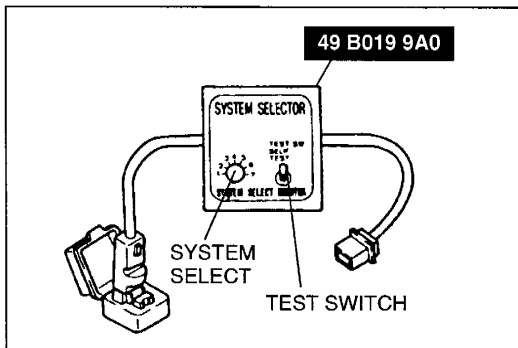

BAC Valve Operation Inspection

1. Connect the **SST** (System Selector) to the data link connector.
2. Set switch A to position 1.
3. Set the test switch to SELF TEST.
4. Connect the **SSTs** (NGS) to the data link connector-2.
5. Select the PID/DATA MONITOR AND RECORD function.
6. Verify that the engine is cold condition, and start the engine.
7. Select the "RPM" on the NGS display.
8. Verify that the engine speed decreases as the engine warms up.
9. Disconnect the **SST** (System Selector).
10. If the engine speed will not decrease or decreases slowly, check the water hose connected to BAC valve for leakage and clogs. (Refer to section E.)
11. If the water hose is OK, inspect the following.
 - Air valve (Refer to page F2-8.)
 - IAC valve (Refer to page F2-8.)

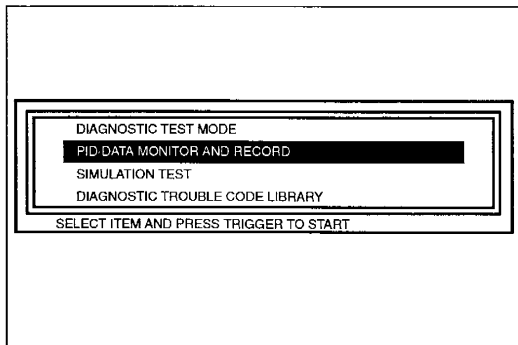

Fuel Injector Operation Inspection

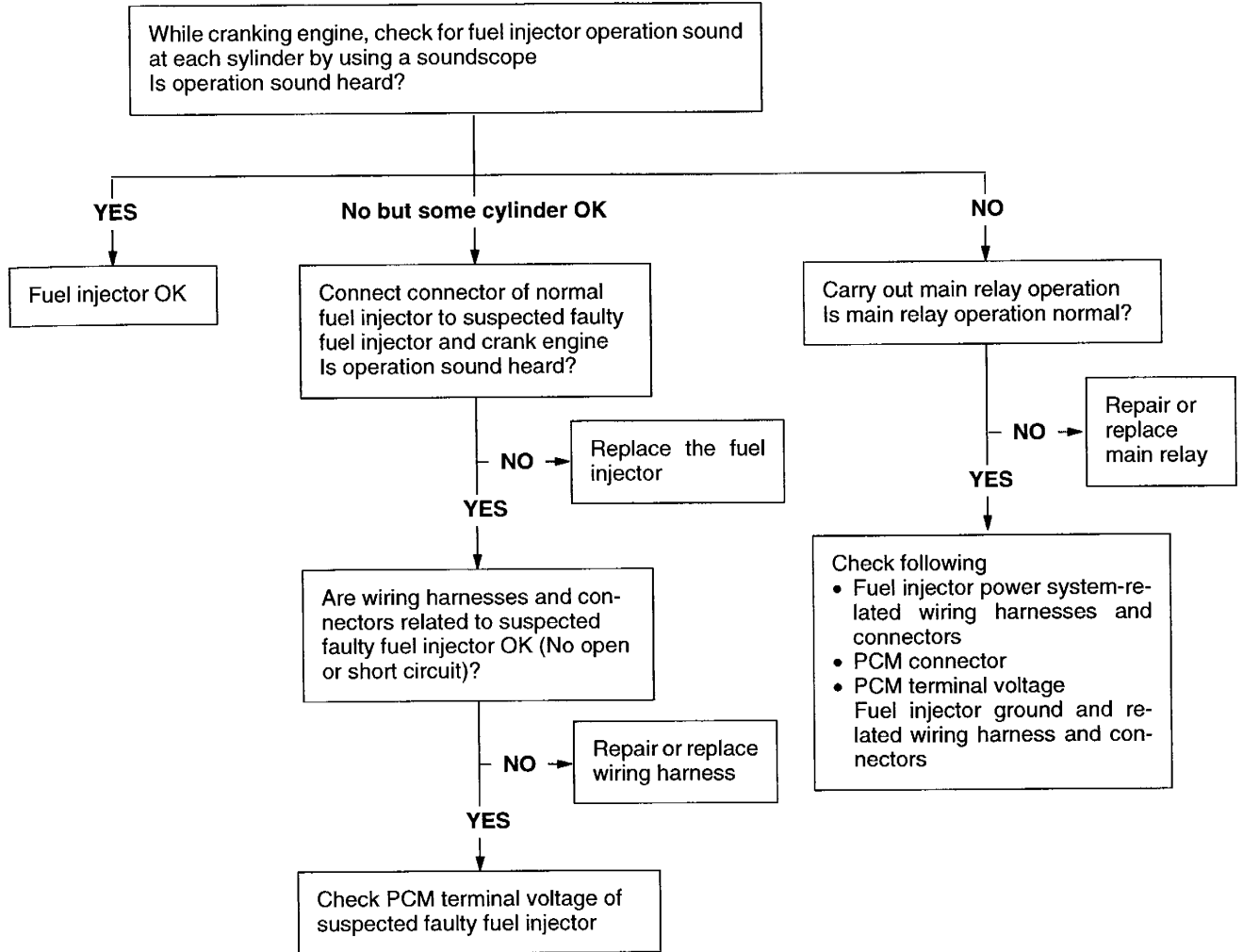

Fuel Cut Control Inspection

1. Warm up the engine to normal operating temperature.
2. Turn off the A/C switch.
3. Connect the **SSTs** (NGS) to the data link connector-2. (Refer to page F2-38.)
4. Select the PID/DATA MONITOR AND RECORD function on the NGS display.
5. Select the "RPM".
6. Using a soundscope, listen for the fuel injector operation sound at all cylinders.

Open throttle valve and increase engine speed to 3,000 rpm. Quickly close throttle valve and check for fuel injector operation sound. Does sound stop when throttle valve is closed and start again when engine speed dropped below 2,000 rpm?

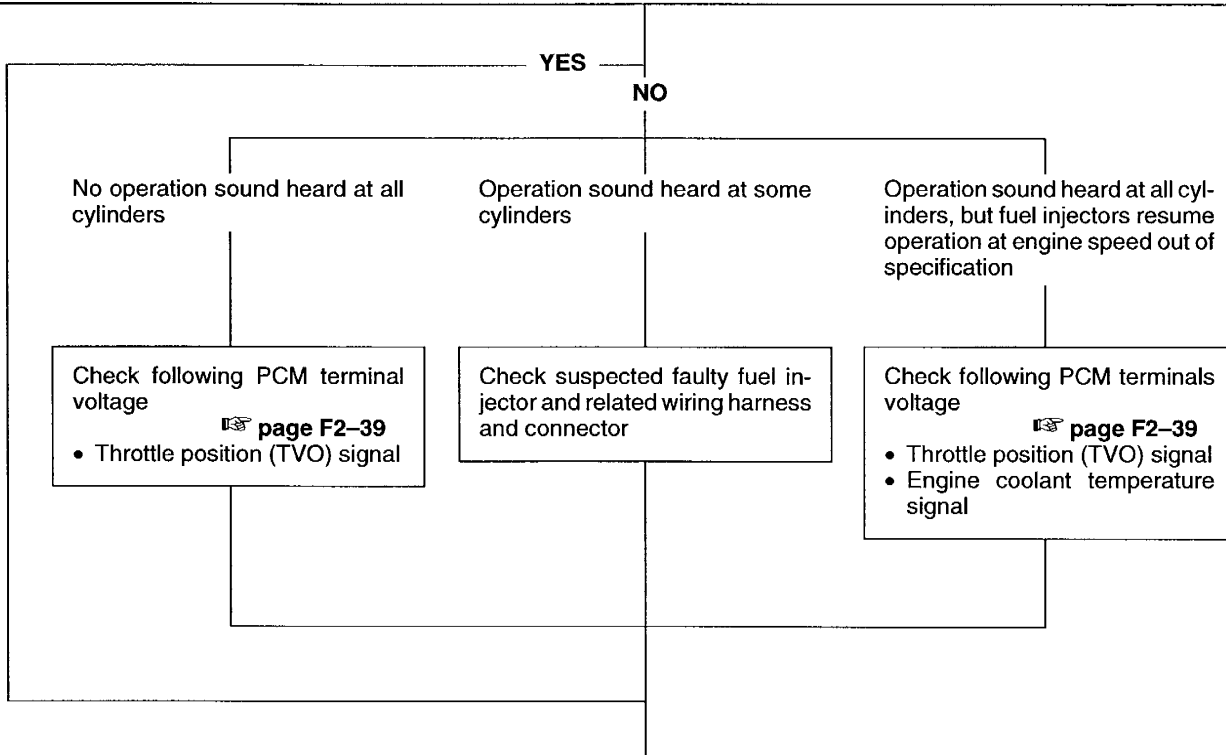

Place a vehicle on chassis roller. Depress accelerator pedal and increase engine speed to 3,000 rpm. Release accelerator pedal (brake pedal not depressed) and check for fuel injector operation sound by using soundscope or oscilloscope at all cylinders. Does sound stop when accelerator pedal is released and start again when engine speed dropped below 2,000 (ATX) or 1,100 (MTX) rpm?

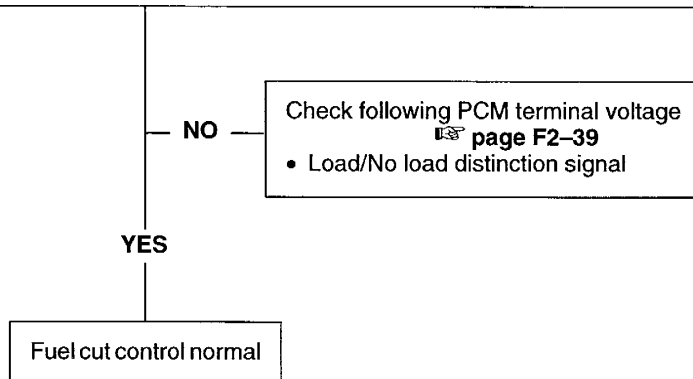

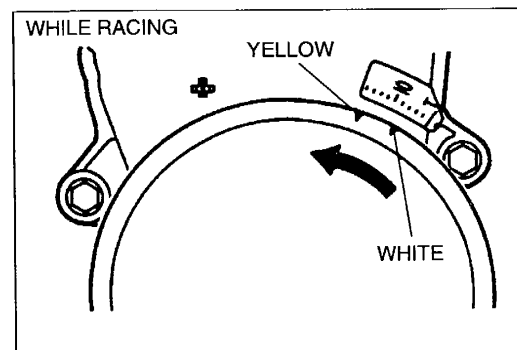
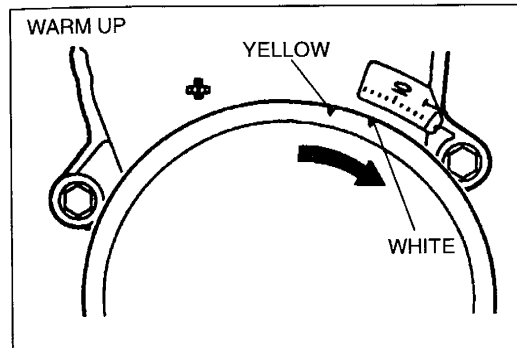
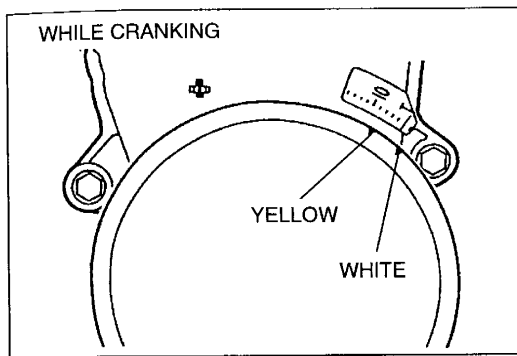

Ignition Timing Control Inspection

1. Connect a timing light to the engine.
2. Crank the engine.
3. Verify that the timing mark (yellow) on the crankshaft pulley and the mark on the timing belt cover are aligned.

Specification: BTDC 6—8 ° (7 ± 1 °)

4. If not as specified, loosen the lock bolt and adjust by turning distributor.
5. If adjustment by turning distributor is not possible, check following.
 - PCM terminal voltage IGT control signal and related wiring harnesses and connectors.
 - Camshaft position sensor (Refer to page F2-45.)
 - Ignition control module (Refer to section G) and related wiring harnesses and connectors.
6. Connect the **SST** (System Selector) to the data link connector.
7. Set switch A to position 1.
8. Set the test switch to SELF TEST.
9. Start the engine.
10. Verify that spark retards as the engine warm up.
11. If not, check the following.
 - Engine coolant temperature sensor (Refer to page F2-48.)
12. Disconnect the **SST** (System Selector).
13. Warm up the engine to normal operation temperature.
14. Verify that the ignition timing is correct. (Refer to page F2-2.)
15. Increase the engine speed and verify that the ignition timing advances accordingly.
16. If not, check following
 - Mass air flow sensor (Refer to page F2-44.)

Purge Control Inspection

1. Start and warm up the engine to normal operating temperature.
2. Let the engine idle.
3. Disconnect the vacuum hose between the purge solenoid valve and the charcoal canister.
4. Put a finger to the purge solenoid valve and verify that there is no vacuum applied.
5. If there is vacuum, do as follows.
 - (1) Connect the **SSTs** (NGS) to the data link connector-2. (Refer to page F2-38.)
 - (2) Verify that diagnostic trouble code No. P0443 is not displayed. If code No. P0443 is shown, carry out troubleshooting of the code No. P0443. (Refer to page F2-75.)
 - (3) If diagnostic trouble codes are not shown, check the following.
 - Purge solenoid valve (Refer to page F2-32.)
6. Reconnect the vacuum hose.
7. Connect the **SSTs** (NGS) to the data link connector-2.
8. Select the SIMULATION TEST function on the NGS display.
9. Increase the duty value of the purge solenoid valve from 0% to 100% by using the "PRGV". Operate the purge solenoid valve and check if the idle condition changes.

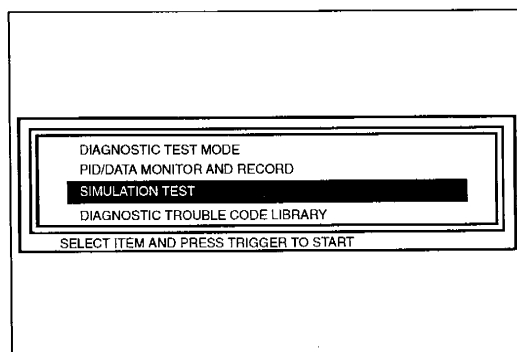

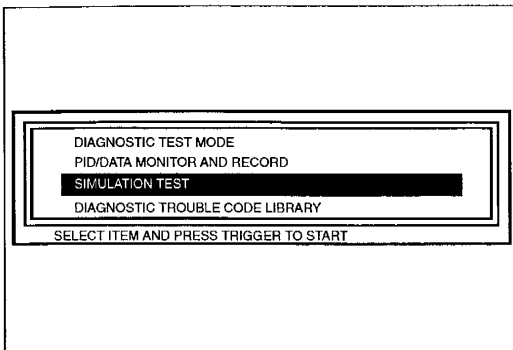

10. If the condition does not change, do as follows.
 - (1) Turn the ignition switch to ON.
 - (2) Verify that diagnostic trouble code No. P0443 is not displayed. If code No. P0443 is shown, carry out troubleshooting of the code No. P0443. (Refer to page F2-75.)
 - (3) Select the SIMULATION TEST function on the NGS display.
 - (4) Increase duty value of the purge solenoid valve from 0% to 100% by using the "PRGV". Operate the purge solenoid valve and check if the operation sound of the valve is heard.
 - I. If the operation sound is heard, check the following.
 - Loose or damaged vacuum hose
 - II. If the operation sound is not heard, check the following.
 - Purge solenoid valve (Refer to page F2-32.)

Idle Air Control Inspection

1. Start the engine and run it at idle.
2. Disconnect the IAC valve connector and verify that the engine rotation changes.
3. If the engine condition will not change, do as follows.
 - (1) Connect the **SSTs** (NGS) to the data link connector-2. (Refer to page F2-38.)
 - (2) Verify that diagnostic trouble code No. P0505 is not displayed. If code No. P0505 is shown, carry out troubleshooting of the code No. P0505.
 - (3) Select the SIMULATION TEST function on the NGS display.
 - (4) Change the duty value of the IAC valve to 100% by using the "IACV" and verify that the idle speed increases.
 - a. If the idle speed increases, replace the PCM. (Refer to page F2-36.)
 - b. If the idle speed does not change. Replace the IAC valve. (Refer to page F2-7.)
4. Warm up the engine to normal operating temperature and run it at idle.
5. Turn the electrical loads ON and verify that the engine speed is within the specification.

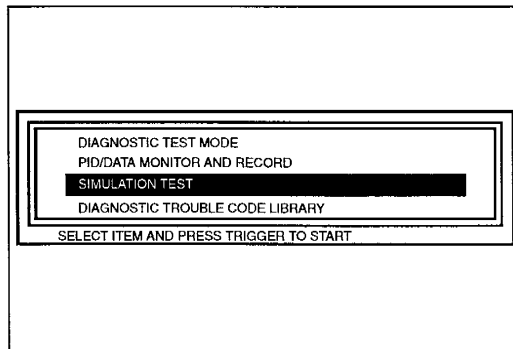

Engine speed (rpm)

Load condition	Idle speed (rpm)	
	MTX	ATX
Fan switch ON at 2nd or higher	700—800	700—800
Headlight switch ON		
Rear window defroster switch ON		
P/S ON		
A/C ON		

Note

- Excludes temporary idle speed drop just after the electrical loads are turned on.

6. If not as specified, check the related switches and wiring harnesses.

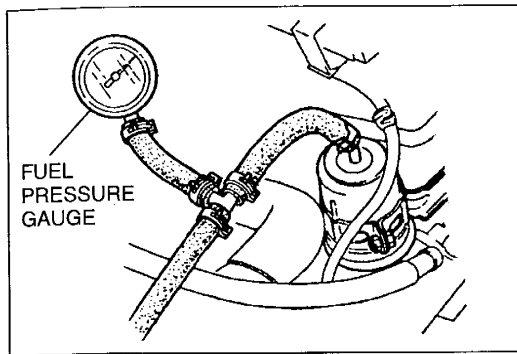

Pressure Regulator Control Inspection

Warning

- Fuel line spills and leaks are dangerous. Fuel can ignite and cause serious injuries or death and damage. Fuel can also irritate skin and eyes. To prevent this, always complete the “Fuel Line Safety Procedures”. (Refer to page F2-11.)

1. Install the fuel pressure gauge.
2. Measure the fuel pressure under the following conditions.

Specifications

	Fuel pressure kPa { kgf/cm ² , psi }		
Idling	216—264 { 2.2—2.7 , 32—38 }	216—264 { 2.2—2.7 , 32—38 }	More than 284 { 2.9 , 41.2 }
During 150 sec. of hot start	More than 284 { 2.9 , 41.2 }		
After 150 sec. of hot start	216—264 { 2.2—2.7 , 32—38 }		
Judgement	Normal	Not normal (Perform Inspection 1)	Not normal (Perform Inspection 2)

3. If the fuel pressure is not within the specification. Carry out either Inspection 1 or Inspection 2.

Inspection 1

1. Stop the engine.
2. Connect the **SSTs** (NGS) to the data link connector-2.
3. Verify that diagnostic trouble code No. P1250 is not displayed. If code No. P1250 is shown. Carry out troubleshooting of the code No. P1250. (Refer to page F2-82.)
4. Start the engine and run it at idle.
5. Select the SIMULATION TEST function on the NGS display.
6. Turn the PRC solenoid valve from OFF to ON by using the “PRCV” and check if the fuel pressure changes.

- (1) If the pressure changes, check the following
 - PCM terminal voltage (Refer to page F2-39.)
 - Engine coolant temperature signal
 - Intake air temperature signal
 - Throttle position signal
- (2) If the pressure does not change, do as follows.
 - I. Stop the engine.
 - II. Turn the ignition switch to ON.
 - III. Turn the PRC solenoid valve from OFF to ON by using the “PRCV” and check if the operation sound of the valve is heard.
 - a. If the operation sound is heard, check the following.
 - Pressure regulator (Refer to page F2-23.)
 - b. If the operation sound is not heard, check the following.
 - PRC solenoid valve (Refer to page F2-24.)

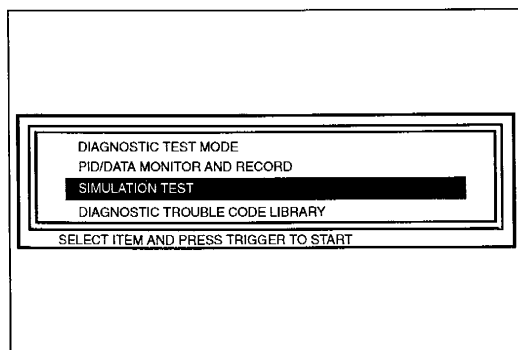

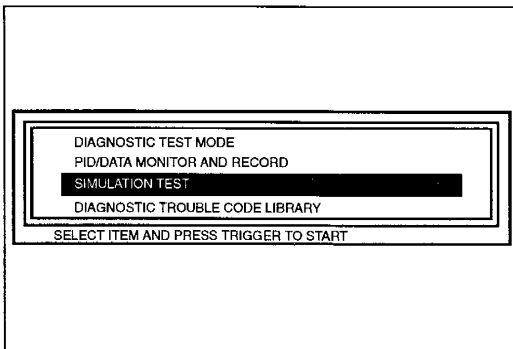
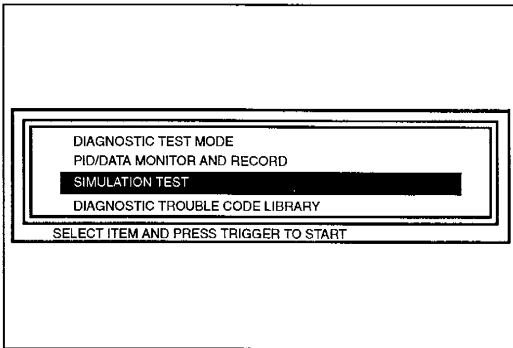
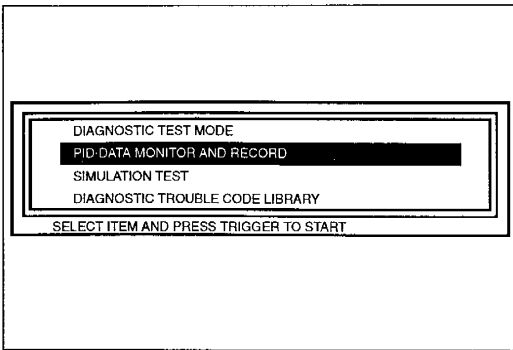

Inspection 2

1. Stop the engine.
2. Connect the **SSTs** (NGS) to the data link connector-2.
3. Verify that diagnostic trouble code No. P1250 is not displayed. If code No. P1250 is shown. Carry out troubleshooting of the code No. (Refer to page F2-82.)
4. Select the PID/DATA MONITOR AND RECORD function on the NGS display.
5. Select the "PRCV" and verify that the PRC solenoid valve is OFF.
6. If the PRC solenoid valve is ON, check the following.
 - PCM terminal voltage (Refer to page F2-39.)
 - Engine coolant temperature signal
 - Intake air temperature signal
7. Select the SIMULATION TEST function on the NGS display.
8. Turn the PRC solenoid valve from OFF to ON using the "PRCV" and check if the operation sound of the valve is heard.
 - (1) If the operation sound is heard, check the following.
 - Loose or damaged vacuum hose between the pressure regulator, PRC solenoid valve, and intake manifold.
 - (2) If the operation sound is not heard, check the following.
 - PRC solenoid valve (Refer to page F2-24.)

EGR Control Inspection

1. Connect the **SSTs** (NGS) to the data link connector-2.
2. Start the engine and let it idle.
3. Select the SIMULATION TEST function on the NGS display.
4. Increase the duty value of EGR solenoid valve (vacuum) from 0% to 100% by using the "EGRVAC". Operate the EGR solenoid valve (vacuum) and check if the engine speed becomes unstable or the engine stalls.
5. If the engine speed will not change, stop the engine and do as follows.
 - (1) Turn the ignition switch to ON.
 - (2) Verify that diagnostic trouble code No. P1485, P1486 is not displayed. If code No. P1485, P1486 is shown, carry out troubleshooting of the code No. P1485, P1486. (Refer to page F2-87.)
 - (3) Increase the duty value of the EGR solenoid valve (vacuum) from 0% to 100% by using the "EGRVAC". Operate the EGR solenoid valve and check if operation sound of the valve is heard.
 - I. If the operation sound is heard, check the following.
 - Loose or damaged vacuum hose
 - EGR valve (Refer to page F2-32.)
 - EGR solenoid valve (vent)
(Refer to page F2-33.)
 - II. If the operation sound is not heard, check the following.
 - EGR solenoid valve (vacuum)
(Refer to page F2-33.)

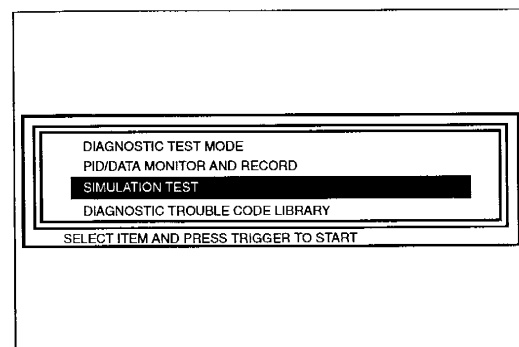
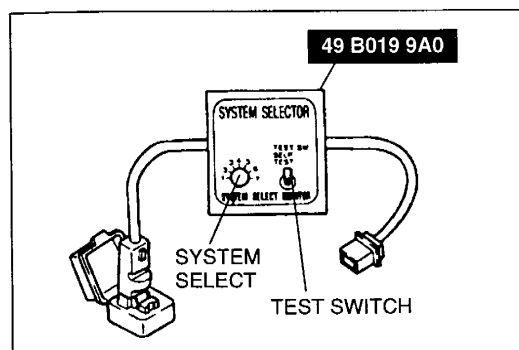
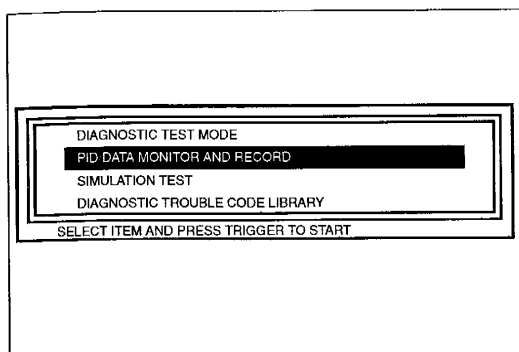

Cooling Fan Control Inspection

1. Verify that the engine is cold.
2. Turn the ignition switch to ON.
3. Verify that the cooling fan is not operating.
4. If the cooling fan is operating, do as follows.
 - (1) Connect the **SSTs** (NGS) to the data link connector-2. (Refer to page F2-38.)
 - (2) Select the PID/DATA MONITOR AND RECORD function on the NGS display.
 - (3) Select the "FANC" and verify that the cooling fan control signal is OFF.
 - I. If the cooling fan control signal is ON, check the following.
 - PCM terminal voltage (Refer to page F2-39.)
 - Engine coolant temperature signal
 - II. If the cooling fan control signal is OFF, check the following.
 - Cooling fan relay (Refer to page section E.)
 - Short circuit in wiring harnesses and connectors (Main relay — Cooling fan relay — PCM)
5. Connect the **SST** (System Selector) to the data link connector.
6. Set switch A to position 1.
7. Set the test switch to SELF TEST.
8. Depress the accelerator pedal and verify that the cooling fan operates.
9. If the cooling fan does not operate, do as follows.
 - (1) Connect the **SSTs** (NGS) to the data link connector-2.
 - (2) Select the SIMULATION TEST function on the NGS display.
 - (3) Turn the cooling fan relay from OFF to ON by using the "FANC" and check for the cooling fan operation.
 - I. If the cooling fan operates, check the following.
 - PCM terminal voltage (Refer to page F2-39.)
 - Test mode signal
 - Throttle position signal
 - II. If the cooling fan does not operate, do as follows.
 - a. Turn the cooling fan relay from OFF to ON by using the simulation function. Operate the cooling fan relay and check if the operation sound of the relay is heard.
 - b. If the operation sound is heard, check the following.
 - Wiring harnesses and connectors (Cooling fan relay — Cooling fan motor)
 - Cooling fan motor (Refer to section E.)
 - c. If the operation sound is not heard, check the following.
 - Cooling fan relay (Refer to section E.)
 - Open circuit in wiring harnesses and connectors (Main relay — Cooling fan relay — PCM)

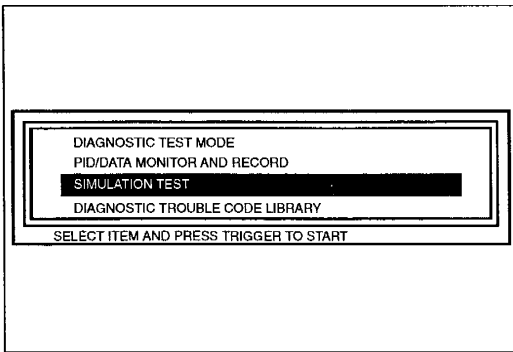

Condenser Fan Relay

1. Verify that the A/C switch and fan switch are OFF.
2. Start the engine and let it idle.
3. Verify that the condenser fan is not operating.
4. If the condenser fan is operating, check the short circuit in wiring between condenser fan relay and PCM terminal1B.
5. Turn the A/C switch and fan switch on.
6. Verify that the condenser fan is operating.
7. Turn the A/C switch and fan switch off.
8. If the condenser fan does not operate, do as follows
 - (1) Connect the **SSTs** (NGS) to the data link connector-2. (Refer to page F2-38.)
 - (2) Select the SIMULATION TEST function on the NGS display.
 - (3) Turn the condenser fan relay from OFF to ON by using the "FANN" and check for the condenser fan operation.
 - I. If the condenser fan operates, check the following.
 - PCM terminal voltage (Refer to page F2-39.)
 - A/C signal
 - II. If the condenser fan does not operate, do as follows.
 - a. Turn the condenser fan relay from OFF to ON by using the simulation function. Operate the condenser fan relay and check if the operation sound of the relay is heard.
 - b. If the operation sound is heard, check the following.
 - Wiring harness and connectors (Condenser fan relay — Condenser fan motor)
 - Condenser fan motor (Refer to section U.)
 - c. If the operation sound is not heard, check the following.
 - Condenser fan relay (Refer to section U.)
 - Open circuit in wiring harness and connectors (Main relay — Condenser fan relay — PCM)

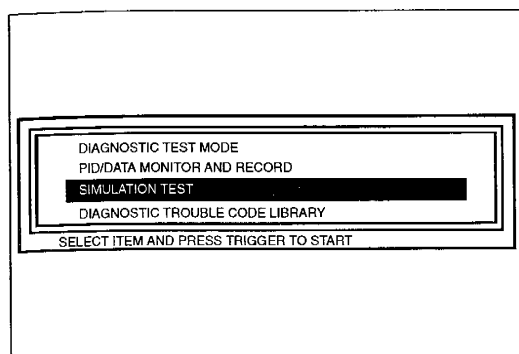

A/C Cut-off Control Inspection

1. Start the engine and let it idle.
2. Turn the A/C switch and the fan switch ON.
3. Fully open the throttle valve. Then 3—6 seconds after, check if the operation sound of the A/C compressor electromagnetic clutch is heard.
4. If the operation sound is not heard, do as follows.
 - (1) Connect the **SSTs** (NGS) to the data link connector-2. (Refer to page F2-38.)
 - (2) Select the SIMULATION TEST function on the NGS display.
 - (3) Turn the A/C relay from OFF to ON by using the “A/C RLY” function and check for the operation sound of the relay.
 - I. If the operation sound is heard, check the following.
 - PCM terminal voltage (Refer to page F2-39.)
 - Load/no load judgement signal
 - Throttle position signal
 - II. If the operation sound is not heard, check the following.
 - A/C relay (Refer to section U.)
 - Open circuit in wiring harnesses and connectors (Main relay — A/C relay — PCM)

Before beginning any service procedure, refer to section T1 of this manual for air bag system service warnings.

ENGINE ELECTRICAL SYSTEM

TABLE OF CONTENTS	G- 2
OUTLINE	G- 3
SPECIFICATIONS	G- 3
CHARGING SYSTEM	G- 4
BATTERY	G- 4
GENERATOR	G- 6
IGNITION SYSTEM	G- 8
IGNITION CONTROL MODULE	G- 8
IGNITION COIL	G- 8
DISTRIBUTOR	G- 9
HIGH-TENSION LEAD	G-10
STARTING SYSTEM	G-11
STARTER	G-11
STARTER INTERLOCK SWITCH	G-12

TABLE OF CONTENTS

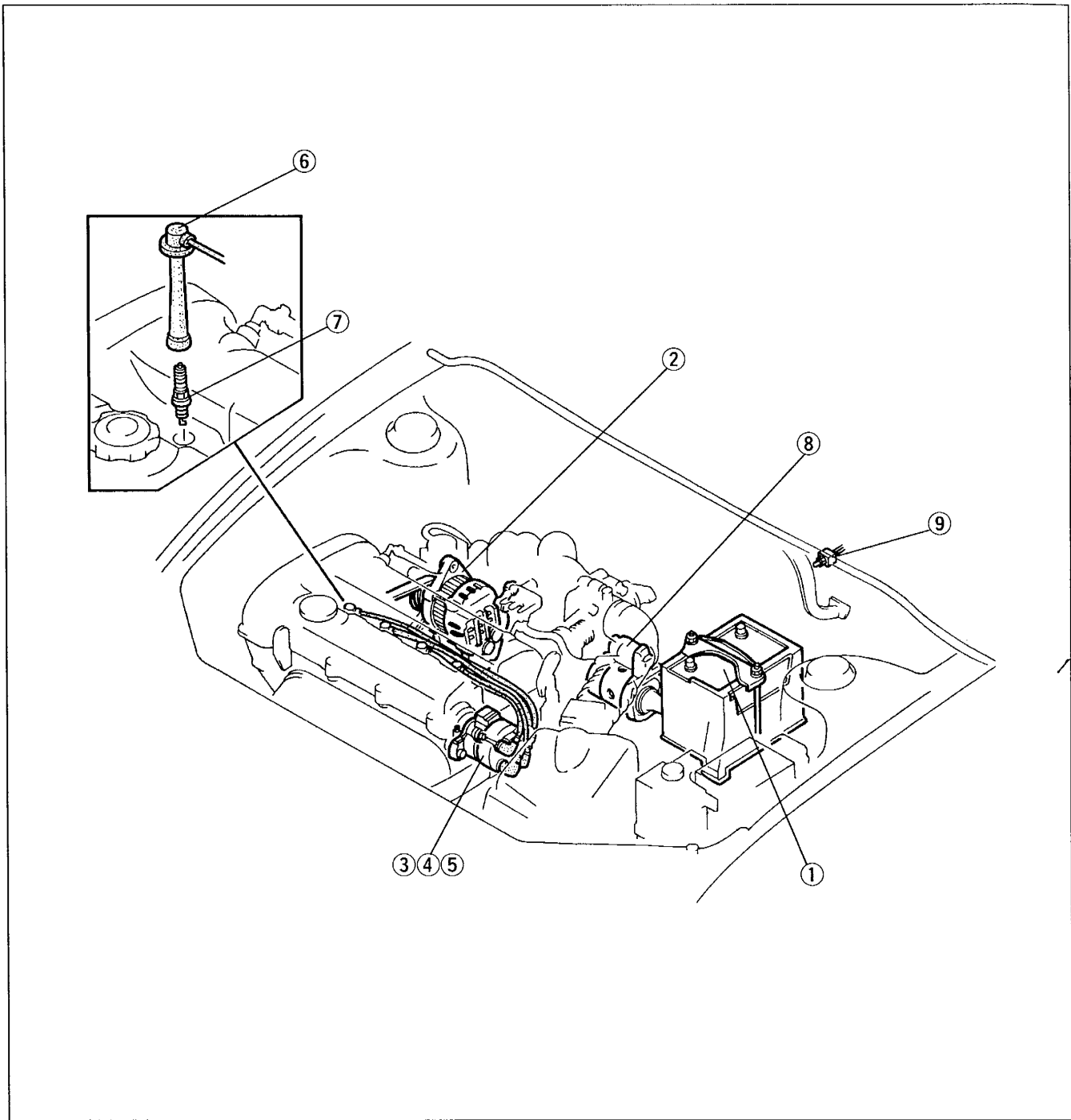

1. Battery		5. Distributor	
Inspection	page G- 4	Removal / Installation	page G- 9
Recharging	page G- 5	Disassembly / Assembly	page G-10
2. Generator		6. High-tension lead	
Removal / Installation	page G- 6	Removal / Installation	page G-10
Inspection	page G- 7	Inspection	page G-10
3. Ignition control module		7. Spark plug	
Inspection	page G- 8	8. Starter	
4. Ignition coil		Removal / Installation	page G-11
Inspection	page G- 8	Inspection	page G-12
		9. Starter interlock switch	
		Inspection	page G-12

OUTLINE

SPECIFICATIONS

Item		Engine/Transaxle		Z5		BP		
		MTX	ATX	MTX	ATX			
Battery	Electrolyte gravity	1.27—1.29 [20 °C { 68 °F }]						
	Dark current* ¹	mA Max. 20						
Generator	Output	V—A		12—65		12—70		
	Rotor resistance (Between slip rings)		Ω		2.5—2.9 [20 °C { 68 °F }]		3.5—4.5 [20 °C { 68 °F }]	
	Brush length	Standard	mm { in }	20.0 { 0.79 }		16.5 { 0.65 }		
		Minimum	mm { in }	5.0 { 0.20 }		8.0 { 0.32 }		
	Brush spring force	Standard	N { kgf , lbf }	4.71—5.88 { 0.48—0.60 , 1.06—1.32 }		3.14—4.31 { 0.32—0.44 , 0.71—0.96 }		
		Minimum	N { kgf , lbf }	2.36—3.13 { 0.24—0.32 , 0.53—0.70 }		1.57—2.35 { 0.16—0.24 , 0.36—0.52 }		
Ignition coil	Resistance	Primary coil* ²	Ω	0.49—0.73 [20 °C { 68 °F }]		—		
		Secondary coil	kΩ	20—31 [20 °C { 68 °F }]				
Distributor	Gap		mm { in }		0.9 { 0.04 }			
	Firing order		1—3—4—2					
High-tension lead	Resistance	kΩ/m		16 [20 °C { 68 °F }]				
Spark plug	Plug gap		mm { in }		1.0—1.1 { 0.040—0.043 }			
	Resistance		kΩ		3.0—7.5 [20 °C { 68 °F }]			
	Tightening torque		N·m { kgf·m , ft·lbf }		15—22 { 1.5—2.3 , 11—16 }			
Starter	Commutator diameter	Standard	mm { in }	32.0 { 1.26 }		29.4 { 1.16 }		
		Minimum	mm { in }	31.4 { 1.24 }		28.8 { 1.14 }		
	Brush length	Standard	mm { in }	17.0 { 0.67 }		12.5 { 0.49 }		
		Minimum	mm { in }	11.5 { 0.46 }		7.0 { 0.28 }		
	Brush spring force	Standard	N { kgf , lbf }	20.6 { 2.10 , 4.62 }		17.7 { 1.80 , 3.96 }		
		Minimum	N { kgf , lbf }	6.86 { 0.70 , 1.54 }		5.88 { 0.60 , 1.32 }		
	Pinion gap		mm { in }		0.5—2.0 { 0.020—0.078 }			

*¹ Dark current is the constant flow of current present when the ignition switch is OFF (i.e., audio unit, clock, etc.).

*² Measurement is available for California models only.

G

CHARGING SYSTEM

BATTERY Inspection

Warning

- Hydrogen gas is produced during normal battery operation. A battery-related explosion can cause serious injury. Keep all flames (including cigarettes), heat, and sparks away from the top and surrounding area of open battery cells.

Caution

- To prevent damage to electrical components or the battery, turn all accessories off and stop the engine before performing maintenance or recharging the battery.

Check the battery in the following procedure.

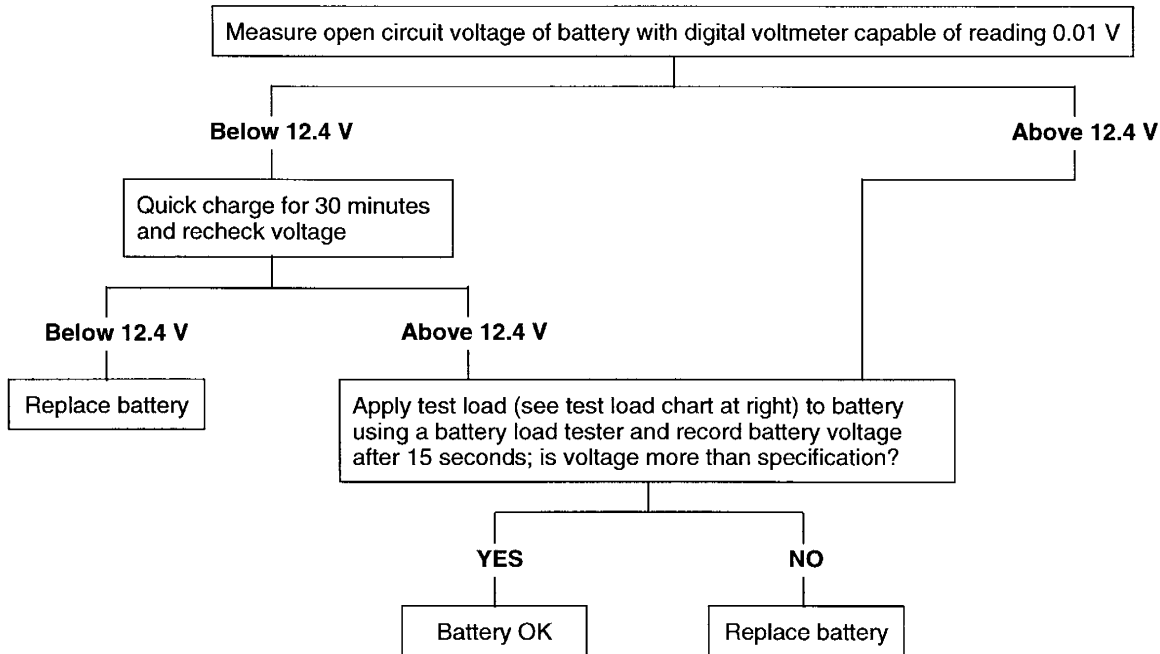

Test load chart

Battery	Load (A)
50D 20L	150
55D 23L	180

Battery voltage with load

Approximate battery temp.	Minimum voltage (V)
21 °C { 70 °F }	9.6
15 °C { 60 °F }	9.5
10 °C { 50 °F }	9.4
4 °C { 40 °F }	9.3
- 1 °C { 30 °F }	9.1
- 7 °C { 20 °F }	8.9
-12 °C { 10 °F }	8.7
-18 °C { 0 °F }	8.5

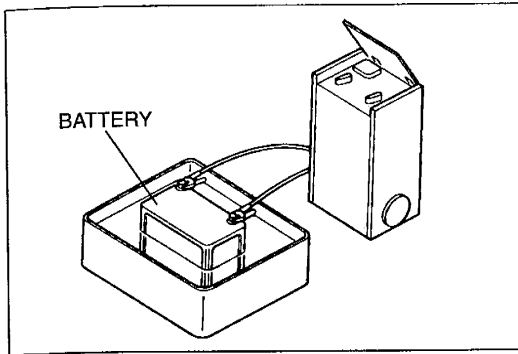

Recharging

Caution

- When disconnecting the battery, remove the negative cable first and install it last to prevent damage to electrical components or the battery.
- Do not quick charge for over 30 minutes. It will damage the battery.

1. Place a battery in a pan of water to prevent it from overheating. The water level should come up about halfway on the battery. Keep water off the top of the battery.
2. Connect a battery charger to the battery.
3. Adjust the charging current as follows.

G

Battery type (5 hour rate)	Slow charge (A)	Quick charge (A)
50D 20L (40)	4.0—5.0	25
55D 23L (48)	4.5—5.5	30

4. After the battery has been recharged, measure the battery voltage and verify that the battery keeps specified voltage for more than 1 hour.

Specification: Above 12.4 V

5. If not as specified, replace the battery.

GENERATOR

Removal / Installation

Warning

- When the battery cables are connected, touching the vehicle body with generator terminal B will generate sparks. This can cause personal injury, fire, and damage to the electrical components. Always disconnect the battery before performing the following operation.

Caution

- Reversing the battery connections or using high-voltage testers will damage the rectifier.
- Do not start the engine while the connector is disconnected from terminals L and S. It can damage the generator.

Note

- Battery positive voltage is always present at generator terminal B when the battery is connected.

1. Disconnect the negative battery cable.
2. Remove the pressure pipe stay. (BP) (Refer to section N.)
3. Remove the EGR solenoid valve bracket. (BP) (Refer to section F2.)
4. Remove in the order shown in the figure, referring to **Removal note**.
5. Install in the reverse order of removal.

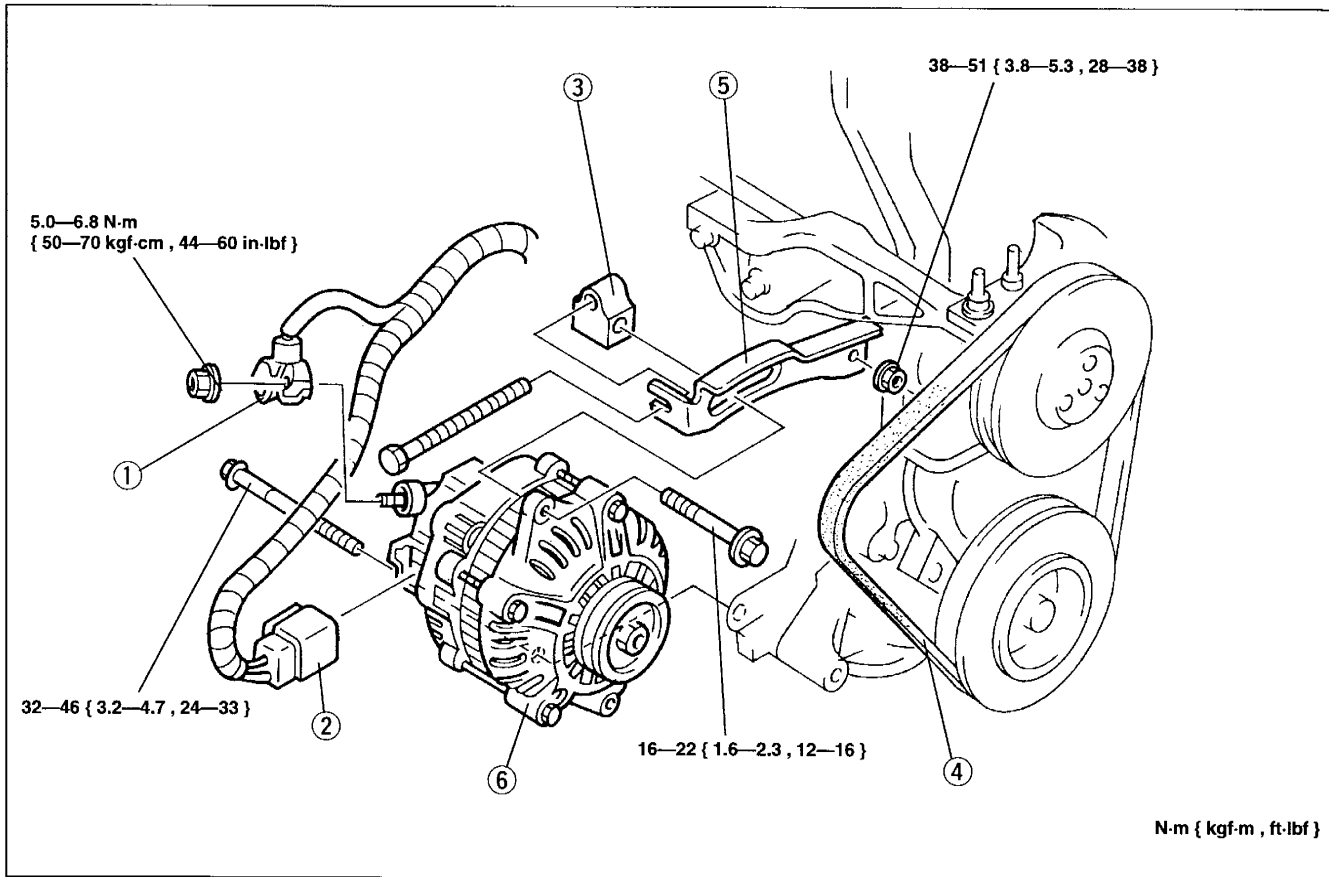

1. Terminal B wire
2. Connector
3. Belt tensioner
4. Drive belt

5. Generator stay (BP)
6. Generator

Removal note below

Removal / Installation sections B1, B2

Removal note

Remove the generator from over the vehicle.

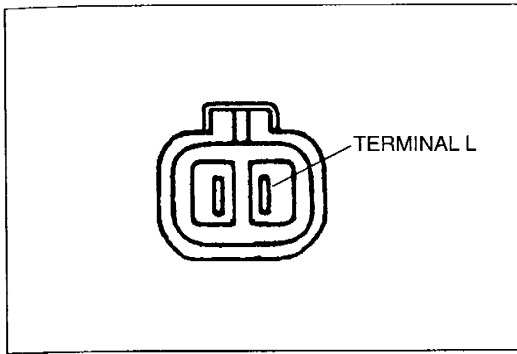

Inspection

Warning light inspection

1. Verify that the battery is fully charged.
2. Verify that the drive belt tension is within the specification. (Refer to sections B1, B2.)
3. Turn the ignition switch to ON and verify that the generator warning light illuminates.
4. If not, check the generator warning light and wiring harnesses between the battery and generator warning light, and between the battery and generator terminal L.
5. Turn the ignition switch to START and verify that the generator warning light goes out after engine starts.
6. If not, inspect the generator.

G

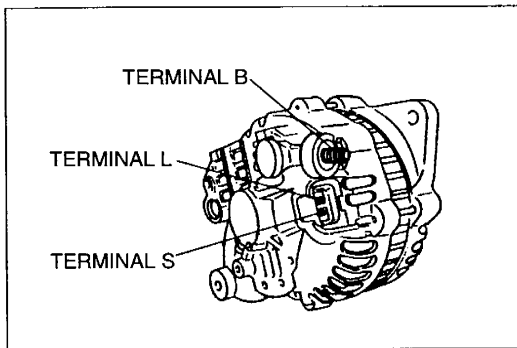

Generator inspection

1. Verify that the drive belt tension is within the specification. (Refer to sections B1, B2.)
2. Turn off all electrical loads.
3. Turn the ignition switch to START and verify that the generator turns smoothly without any noise while the engine is running.
4. Measure the voltage at the terminals shown in the table.

Standard voltage

B+: Battery positive voltage

Terminal	Ignition switch ON	Idle [20 °C { 68 °F }]
B	B+	14.1—14.7 V
L	Approx. 1 V	14.1—14.7 V
S	B+	14.1—14.7 V

5. Measure the current at terminal B as shown in the table.

Standard current

Terminal	Idle (A)	2,000 rpm (A)
B	55	70

6. If the voltage and/or current are not as specified, turn on the following electrical loads one by one. Verify that the current at generator terminal B increases accordingly.
 - **Headlight**
 - **Blower motor**
 - **Rear window defroster**
7. If not, disassemble and inspect the generator.

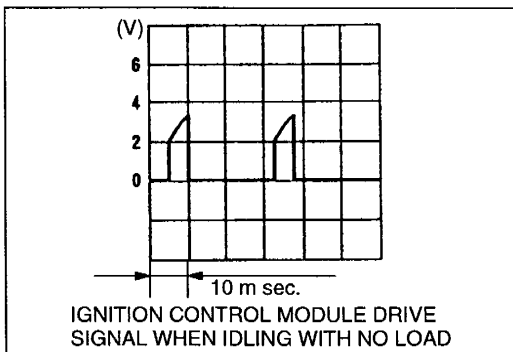

Z5 CALIFORNIA MODELS

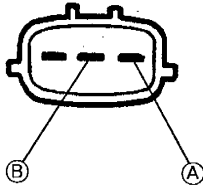

EXCEPT Z5 CALIFORNIA MODELS

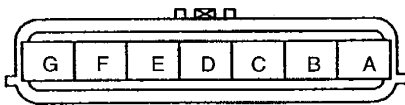

IGNITION SYSTEM

IGNITION CONTROL MODULE

Inspection

Check the distributor cap, ignition coil, ignition control module-related terminal voltages, distributor-related wiring harnesses and the distributor connector. If all of these are normal and still no firing is observed, replace the distributor.

Note

- If the ignition control module drive signal pulse output is not normal, check the related input signals.

IGNITION COIL

Inspection

Primary coil winding

Z5 California models only

1. Disconnect the distributor connector.
2. Measure the resistance between terminals A and B by using an ohmmeter.

Specification: 0.49—0.73 Ω [20 °C { 68 °F }]

3. If not as specified, replace the distributor.

Secondary coil winding

1. Disconnect the distributor connector.
2. Remove the distributor cap.
3. Measure the resistance between terminal A (G^{*1}) and the body by using an ohmmeter.

^{*1} Except Z5 California models

Specification: 20—31 k Ω [20 °C { 68 °F }]

4. If not as specified, replace the distributor.

DISTRIBUTOR

Removal / Installation

1. Disconnect the negative battery cable.
2. Remove the air cleaner. (Refer to sections F1, F2.)
3. Remove in the order shown in the figure.
4. Install in the reverse order of removal.
5. Adjust the ignition timing. (Refer to sections F1, F2.)

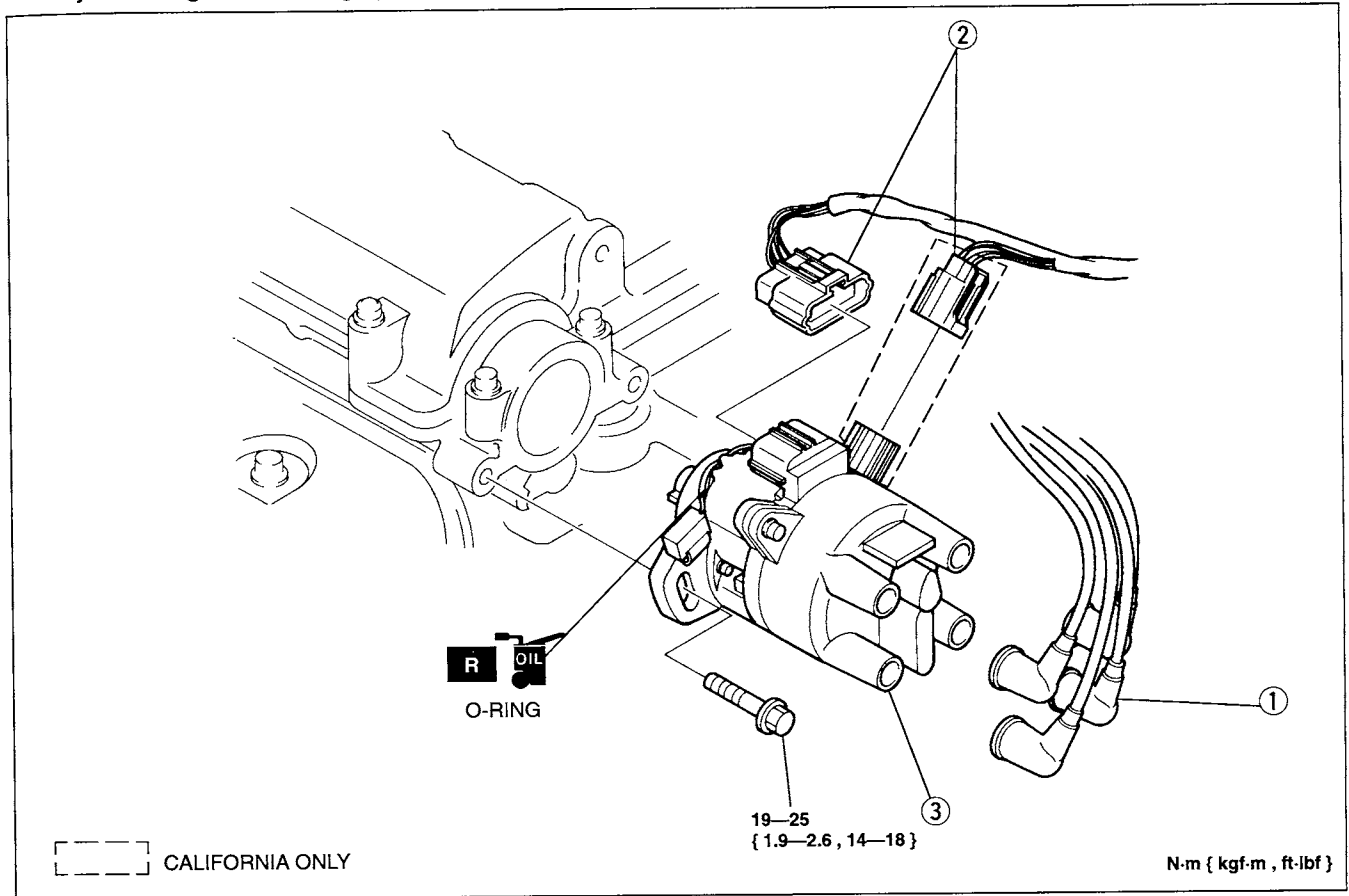

1. High-tension lead
2. Connector

3. Distributor

Disassembly / Assembly

1. Remove the distributor.
2. Disassemble in the order shown in the figure.
3. Assemble in the reverse order of disassembly.

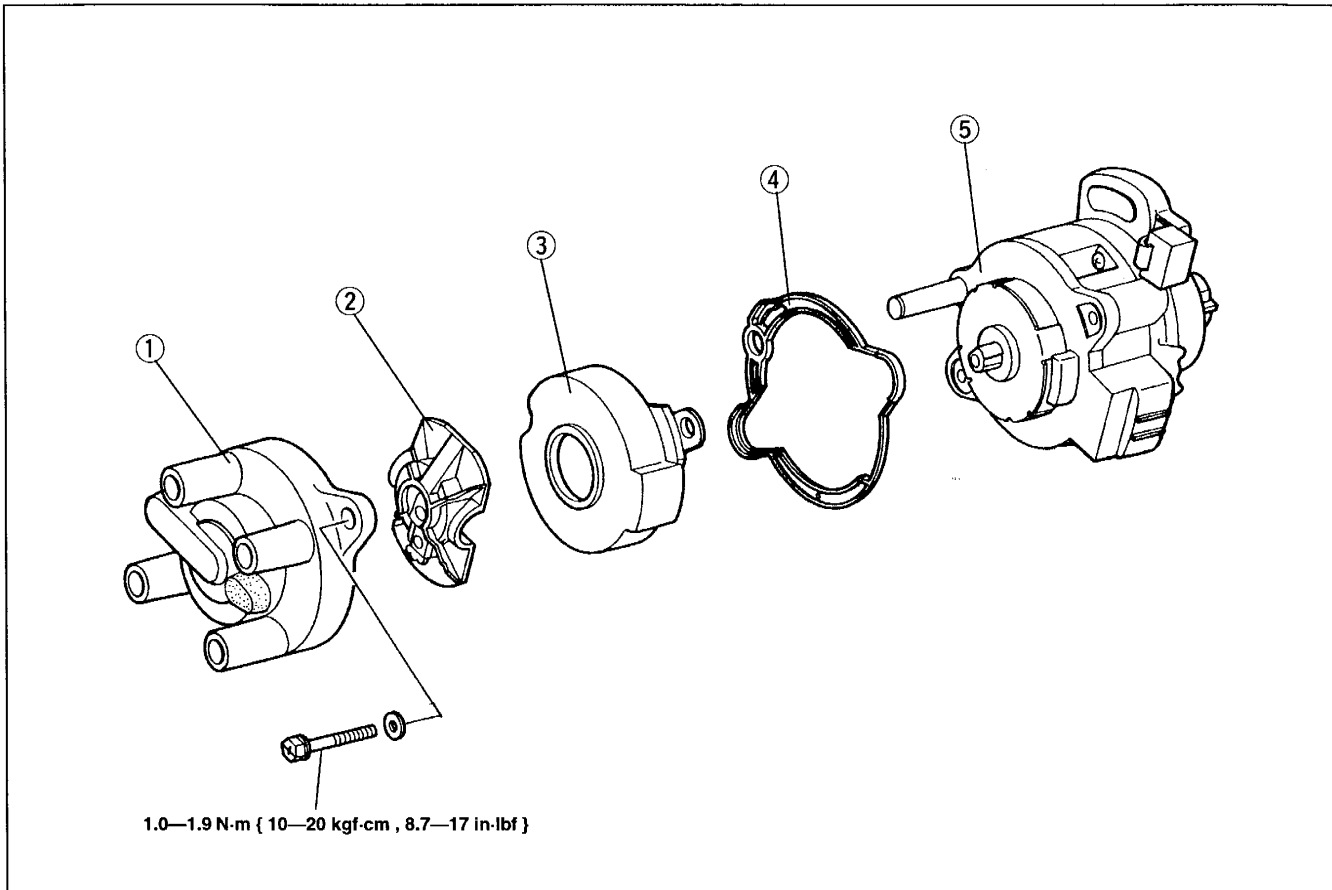

- | | |
|--------------------|---|
| 1. Distributor cap | 5. Distributor |
| 2. Rotor | (Incorporates camshaft position sensor, |
| 3. Cover | ignition control module, and ignition coil) |
| 4. Packing | |

HIGH-TENSION LEAD
Removal / Installation
Caution

- Reinstall the high-tension leads to their original positions. Incorrect installation can damage the leads and cause power loss, and negatively effect electronic components.

Inspection

1. Measure the resistance of the high-tension leads.

Specification: 16 k Ω per 1.00 m { 3.28 ft } [20 °C { 68 °F }]

2. If not as specified, replace the high-tension lead.

STARTING SYSTEM

STARTER

Removal / Installation

1. Disconnect the negative battery cable.
2. Remove the air cleaner. (Refer to sections F1, F2.)
3. Remove the three way catalytic converter. (Refer to sections F1, F2.)
4. Remove in the order shown in the figure.
5. Install in the reverse order of removal.

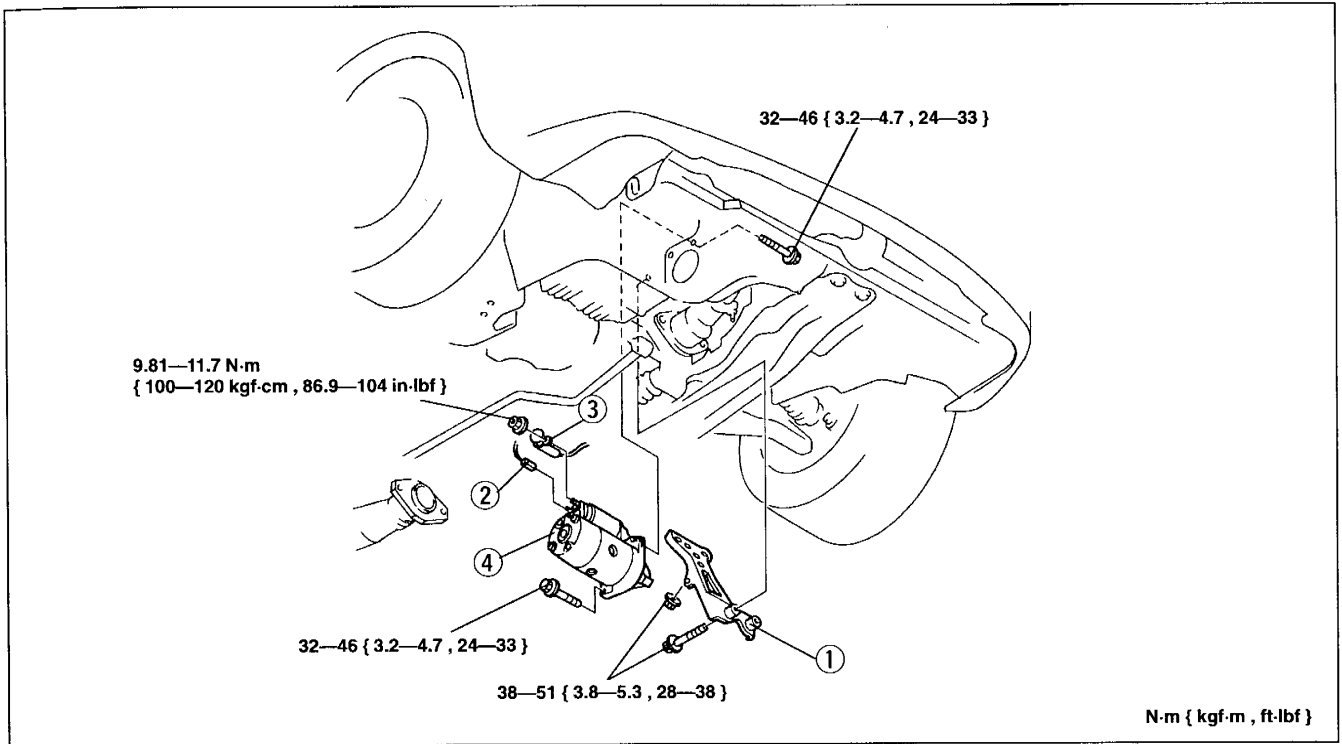

1. Intake manifold stay
2. Terminal S connector

3. Terminal B wire
4. Starter

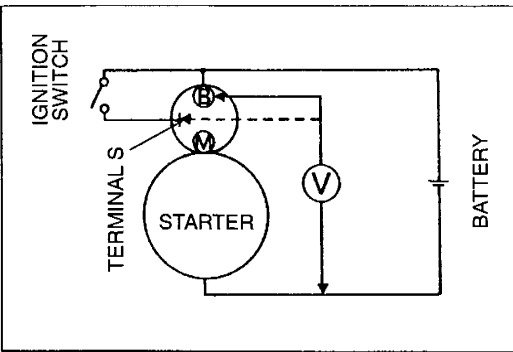

Inspection

On-vehicle inspection

1. Verify that the battery is fully charged.
2. Crank the engine and verify that the starter turns smoothly without any noise.
3. If not as specified, measure the voltage at terminals S and B when the ignition switch is in START position.

Voltage: 8 V min.

4. If the voltage is within the specification, remove the starter and inspect the magnetic switch and the starter.
5. If the voltage is not as specified, check the wiring harness, ignition switch, starter interlock switch (MTX), and transaxle range switch (ATX).

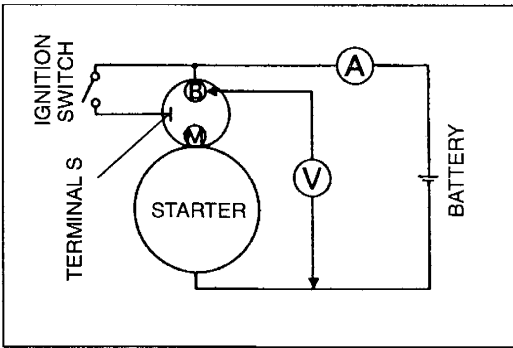

No load test

1. Connect the starter, battery, voltmeter and ammeter as shown.
2. Measure the voltage, current, and speed as shown below.

Engine	Z5		BP	
	MTX	ATX	MTX	ATX
Voltage (V)	11.5		11.5	11
Current (A)	Max. 60		Max. 60	Max. 90
Speed (rpm)	Min. 6,500		Min. 6,600	Min. 2,800

3. If not as specified, repair or replace inner parts as necessary.

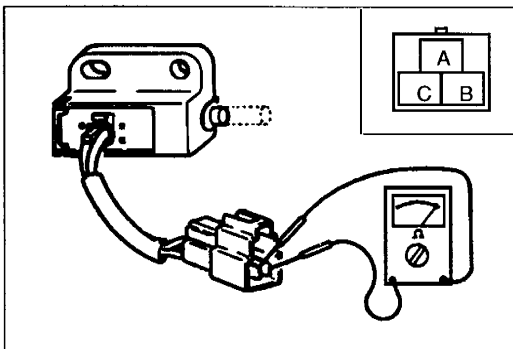

STARTER INTERLOCK SWITCH

Inspection

1. Disconnect the starter interlock switch connector.
2. Check for continuity between terminals of the starter interlock switch by using an ohmmeter.

○—○: Continuity

Condition \ Terminal	B	C
Clutch pedal not depressed		
Clutch pedal depressed	○—○	○—○

3. If not as specified, replace the starter interlock switch.

Before beginning any service procedure, refer to section T1 of this manual for air bag system service warnings.

CLUTCH

GENERAL PROCEDURES	H- 2
CLUTCH FLUID	H- 2
PREPARATION	H- 2
INSPECTION	H- 2
REPLACEMENT/AIR BLEEDING	H- 2
CLUTCH PEDAL	H- 3
INSPECTION / ADJUSTMENT	H- 3
REMOVAL / INSTALLATION	H- 4
CLUTCH MASTER CYLINDER	H- 5
PREPARATION	H- 5
REMOVAL / INSTALLATION	H- 5
DISASSEMBLY / ASSEMBLY	H- 6
CLUTCH RELEASE CYLINDER	H- 7
PREPARATION	H- 7
REMOVAL / INSTALLATION	H- 7
DISASSEMBLY / ASSEMBLY	H- 8
CLUTCH UNIT	H- 9
PREPARATION	H- 9
REMOVAL / INSTALLATION	H-10
CLUTCH COVER	H-13
INSPECTION	H-13
CLUTCH DISC	H-13
INSPECTION	H-13
CLUTCH RELEASE COLLAR	H-14
INSPECTION	H-14
PILOT BEARING	H-14
INSPECTION	H-14
FLYWHEEL	H-14
INSPECTION	H-14

GENERAL PROCEDURES

Clutch pipe

- If a clutch pipe(s) has been disconnected anytime during the procedure, add brake fluid, bleed the clutch, and inspect for leakage after the procedure has been completed.
- If removing the clutch pipe, remove it by using the **SST** (49 0259 770B). If installing the clutch pipe, modify the clutch pipe tightening torque to allow for use of a torque wrench-**SST** (49 0259 770B) combination, and then tighten the clutch pipe by using the **SST** (49 0259 770B). (Refer to section GI "Torque Formulas".)

CLUTCH FLUID

PREPARATION

SST

<p>49 0259 770B</p> <p>Wrench, flare nut</p> 	<p>For air bleeding</p>
--	-------------------------

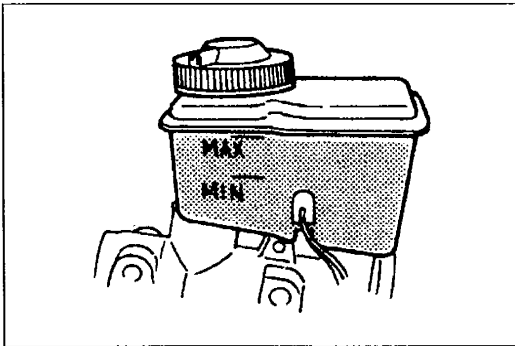

INSPECTION

Note

- A common reservoir is used for the clutch and brake system fluid.
- The fluid in the reservoir must be maintained between the MIN / MAX level during replacement.

REPLACEMENT/AIR BLEEDING

Caution

- **Be careful not to spill the fluid on a painted surface. If this should happen, wash it off immediately.**
- **Do not mix different brands of fluid.**
- **Do not reuse the clutch fluid that was drained.**

1. Drain the brake fluid from the master cylinder through a wheel cylinder. (Refer to section P.)
2. Remove the bleeder cap from the clutch release cylinder and attach a vinyl hose to the bleeder plug.
3. Place the other end of the vinyl hose in a clear container.
4. Slowly pump the clutch pedal several times.
5. With the clutch pedal depressed, loosen the bleeder screw with the **SST** to let the fluid escape. Close the bleeder screw with the **SST**.
6. Repeat Steps 4 and 5 until only clean fluid is seen.
7. Tighten the bleeder screw.

Tightening torque:

5.9—8.8 N·m { 60—90 kgf·cm , 53—78 in·lbf }

8. Bleed the air from the brake system. (Refer to section P.)
9. Add fluid to the MAX mark.

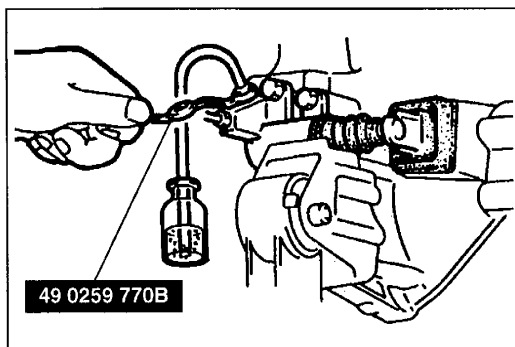

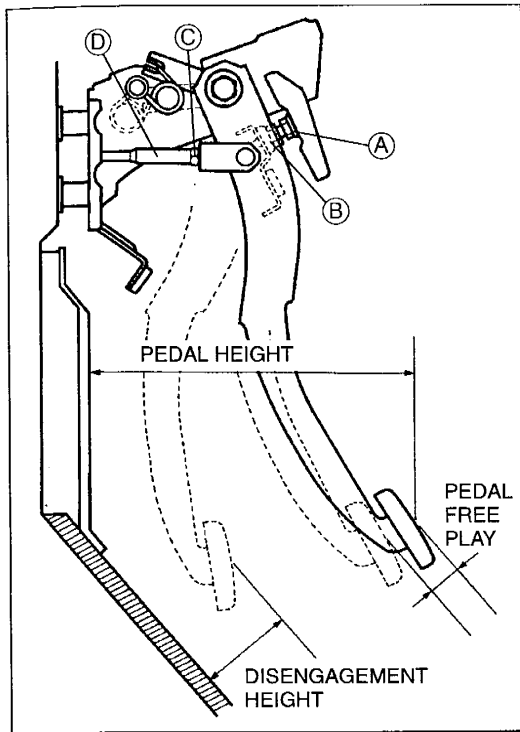

CLUTCH PEDAL

INSPECTION / ADJUSTMENT

Height

1. Measure the distance from the upper surface of the pedal pad to the carpet.

Pedal height:

212—217 mm { 8.35—8.54 in } (with carpet)

2. If necessary, adjust the pedal height by turning locknut (A) and adjustment bolt (B).

Free play

1. Depress the clutch pedal by hand until clutch resistance is felt, and measure the pedal free play.

Free play: 0.7—3.4 mm { 0.03—0.13 in }

Total free play: 5.6—15.0 mm { 0.22—0.59 in }

2. If necessary, adjust the pedal free play by turning locknut (C) and adjusting push rod (D).
3. Verify that the disengagement height (from the upper surface of the pedal pad to the carpet) is correct when the pedal is fully depressed.

Minimum disengagement height:

59 mm { 2.3 in } (with carpet)

REMOVAL / INSTALLATION

1. Remove in the order shown in the figure.

Note

- Apply lithium-based grease to the bushing before installation.

2. Install in the reverse order of removal.

3. After installation, adjust the clutch pedal. (Refer to page H-3.)

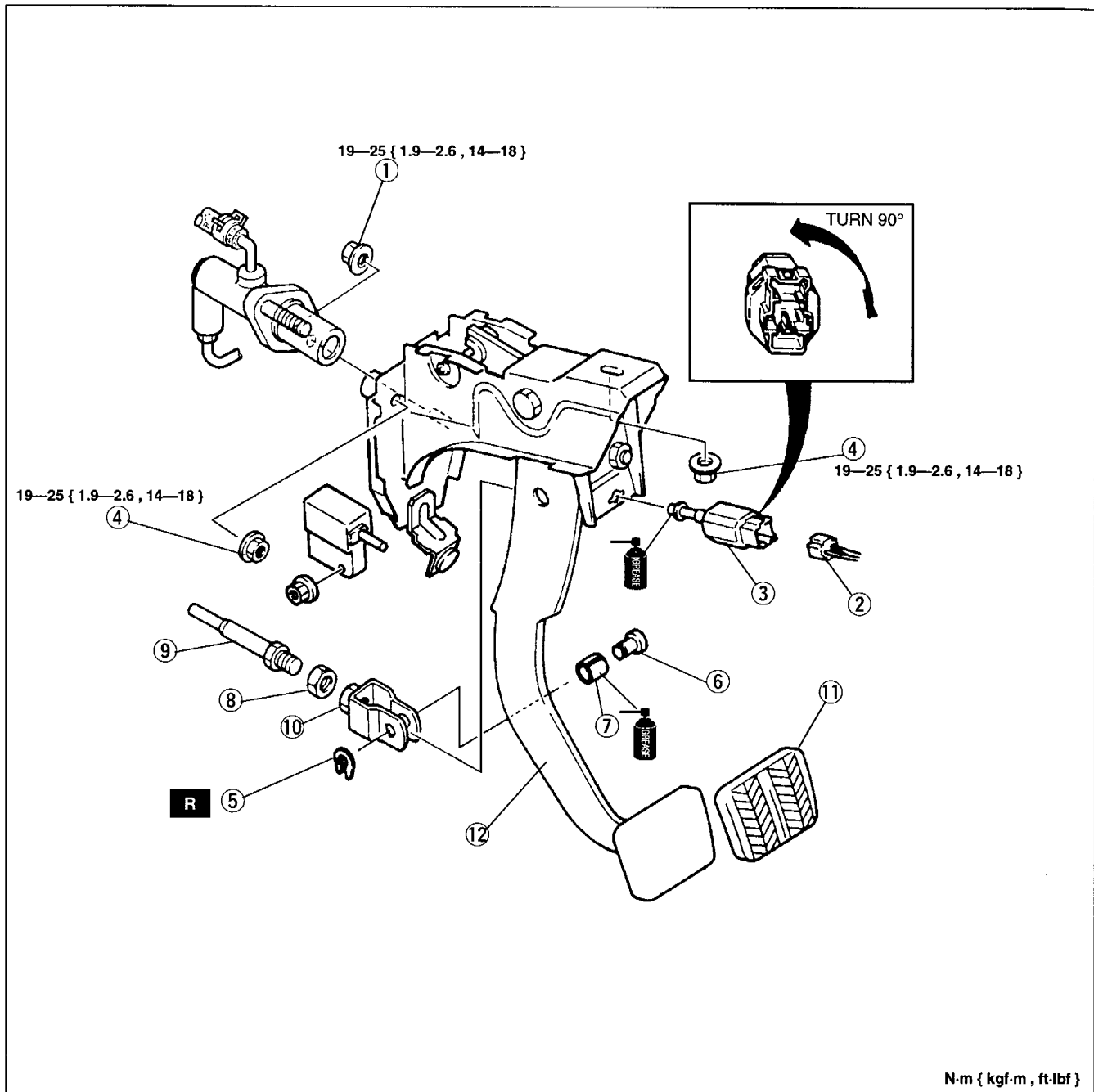

1. Nut
2. Clutch switch connector
3. Clutch switch
4. Nut
5. Clip
6. Pin

7. Bushing
8. Nut
9. Push rod
10. Fork
11. Pedal pad
12. Clutch pedal

CLUTCH MASTER CYLINDER

PREPARATION

SST

49 0259 770B		For disconnecting/ connecting clutch pipe
Wrench, flare nut		

REMOVAL / INSTALLATION

Caution

- Clutch fluid will damage painted surfaces. Be sure to use a container or rags to collect it. If fluid does get on a painted surface, wipe it off immediately with a rag.

H

1. Remove in the order shown in the figure.
2. Install in the reverse order of removal.
3. After installation, inspect and adjust the clutch pedal. (Refer to page H-3.)

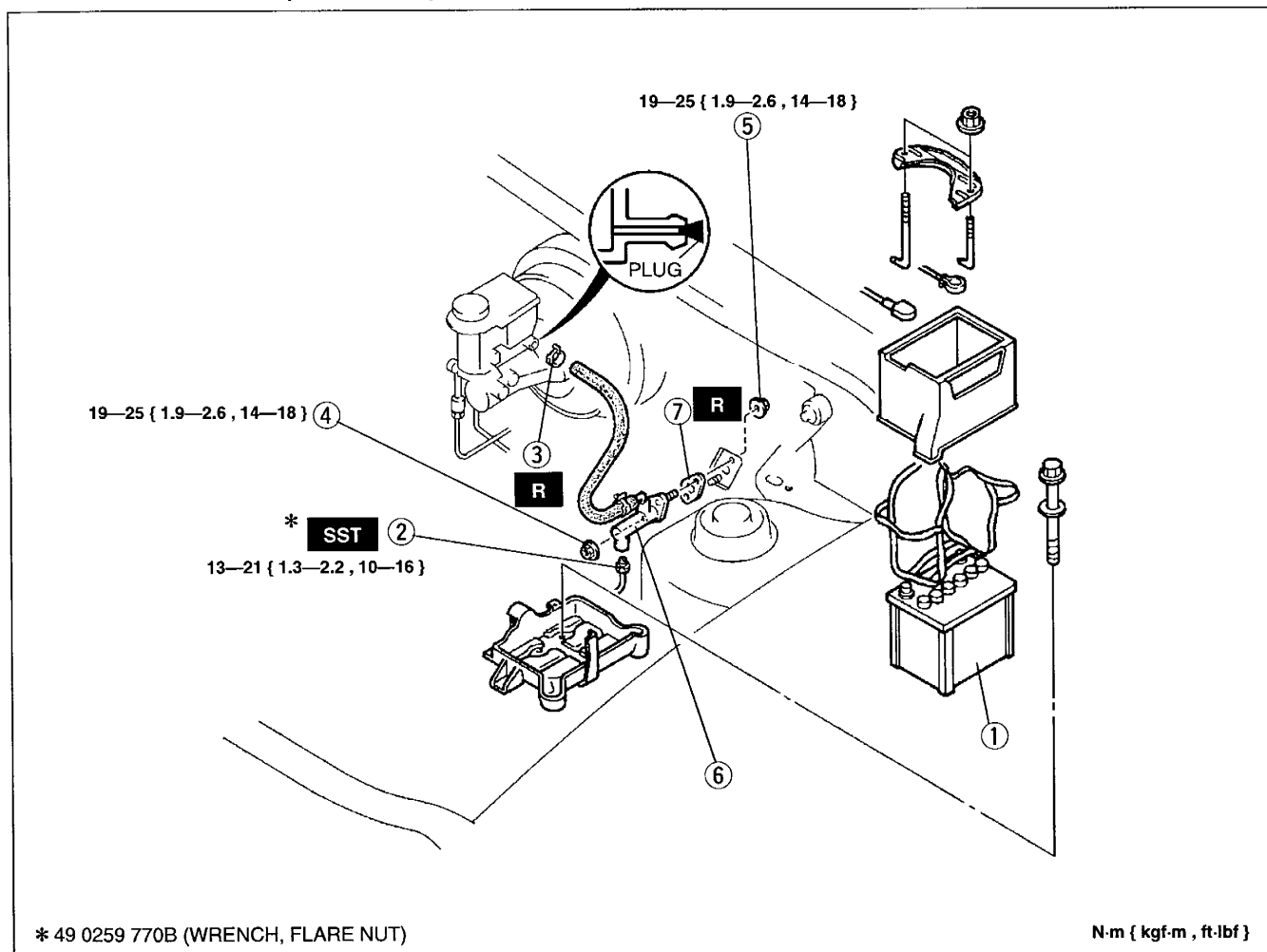

1. Battery
2. Clutch pipe
3. Clip
4. Nut

5. Nut
6. Clutch master cylinder
Disassembly / Assembly page H-6
7. Gasket

DISASSEMBLY / ASSEMBLY

1. Disassemble in the order shown in the figure, referring to **Disassembly Note**.

Warning

- Using compressed air can cause dirt and other particles to fly out, causing injury to the eyes. Wear protective eyewear whenever using compressed air.

2. Wipe all parts, and clean all ports, passages, and inner parts with compressed air.

3. Assemble in the reverse order of disassembly, referring to **Assembly Note**.

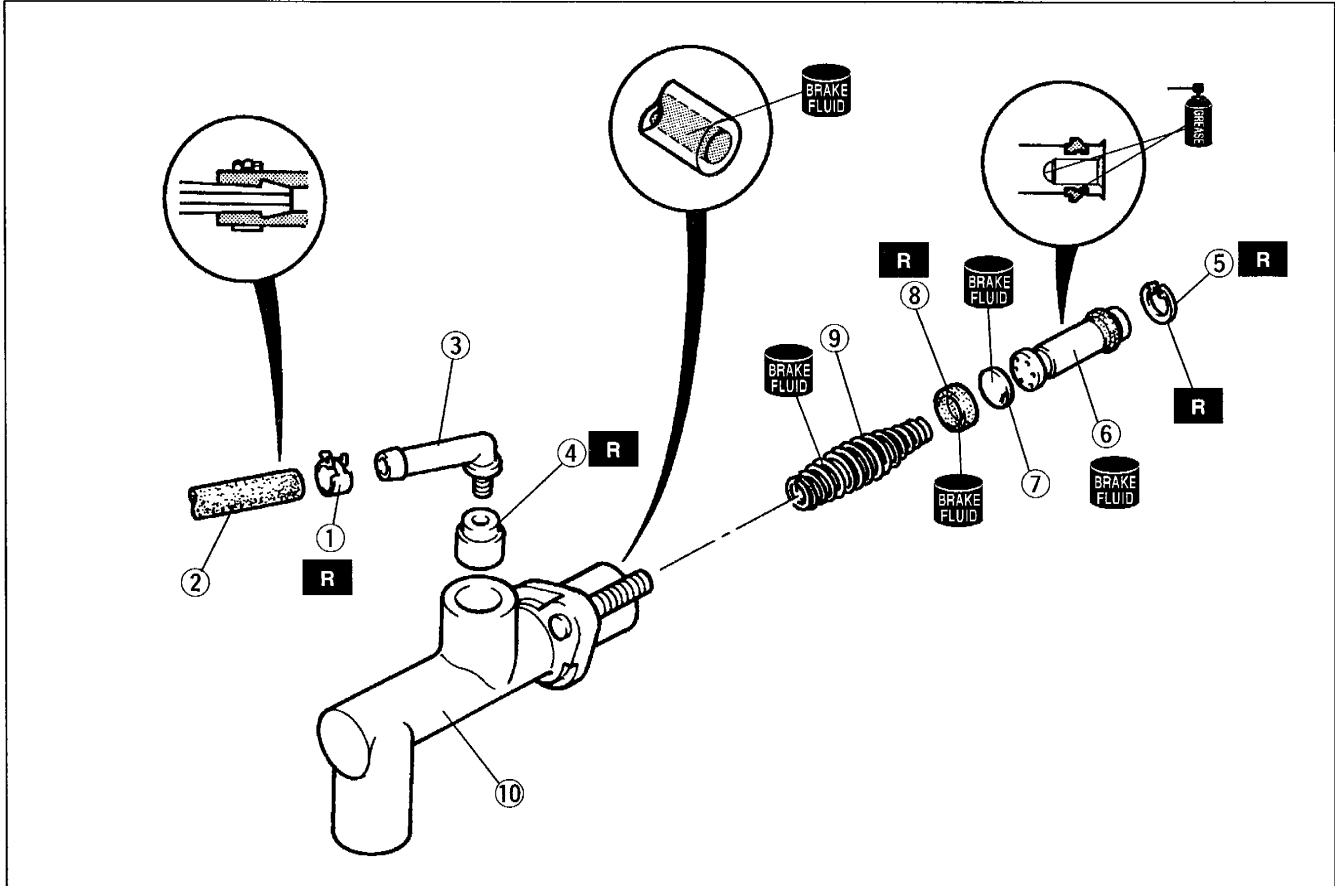

1. Clip

2. Hose

3. Joint

4. Bushing

5. Snap ring

Disassembly / Assembly Note below

6. Piston and secondary cup assembly

7. Spacer

8. Primary cup

Inspect for wear and cracks

9. Return spring

10. Clutch master cylinder body

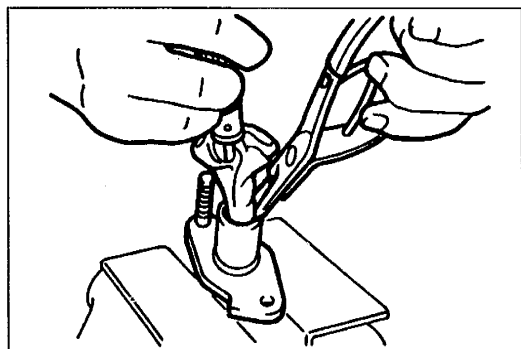

Disassembly / Assembly Note

Snap ring

Hold the piston down with a cloth-wrapped pin punch. If disassembling, remove the snap ring; if assembling, install it.

CLUTCH RELEASE CYLINDER

PREPARATION

SST

<p>49 0259 770B</p> <p>Wrench, flare nut</p> 	<p>For disconnecting/ connecting clutch pipe</p>
--	--

REMOVAL / INSTALLATION

Caution

- Clutch fluid will damage painted surfaces. If clutch fluid does get on a painted surface, wipe it off immediately.

1. Remove in the order shown in the figure.
2. Install in the reverse order of removal.
3. Plug the clutch pipe after removing it to avoid leakage.
4. Bleed the air from the clutch system after installation.

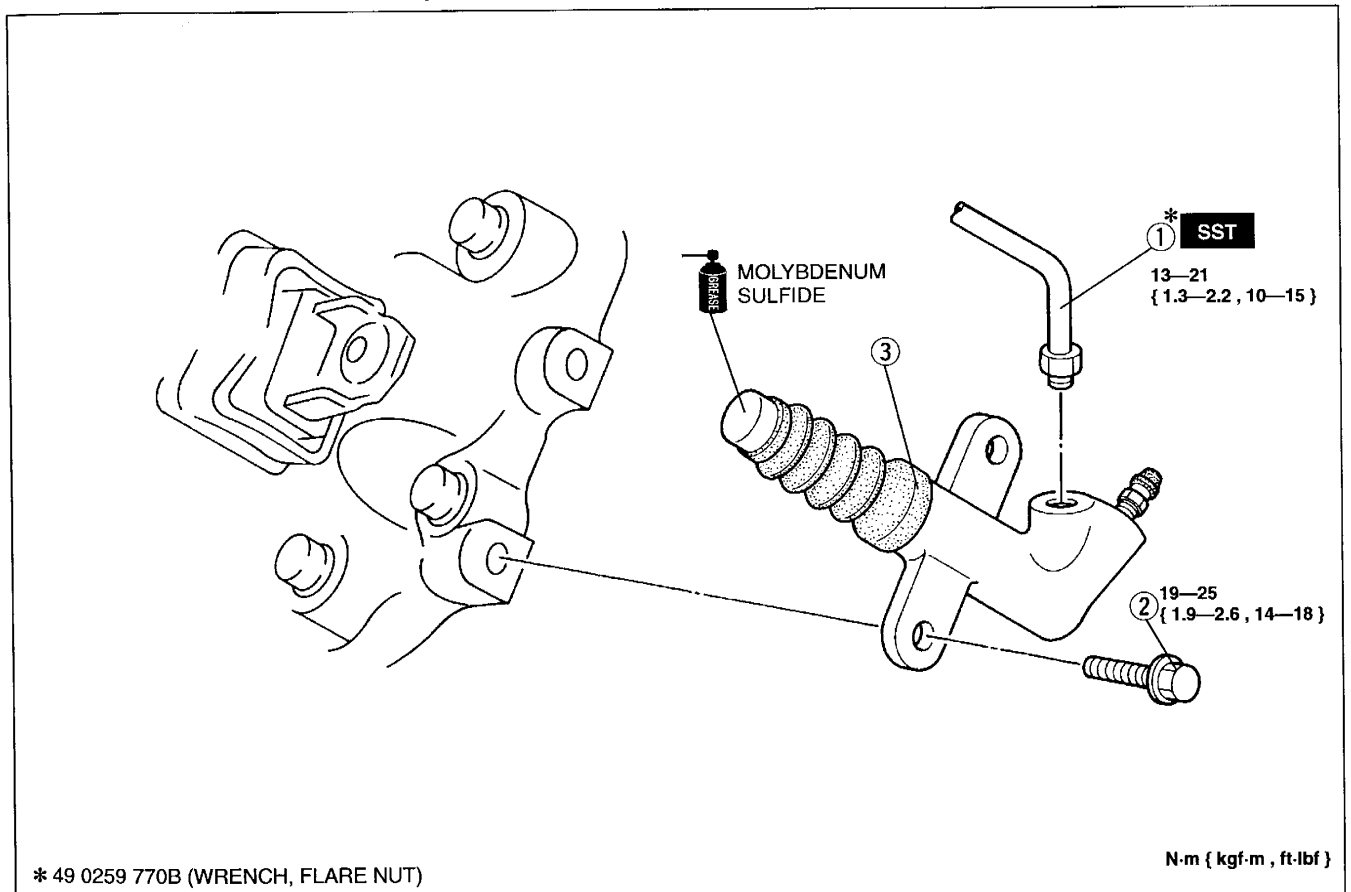

1. Clutch pipe
2. Bolt

3. Clutch release cylinder
Disassembly / Assembly page H-8

DISASSEMBLY / ASSEMBLY

1. Disassemble in the order shown in the figure.

Warning

- Using compressed air can cause dirt and other particles to fly out, causing injury to the eyes. Wear protective eye wear whenever using compressed air.

2. Wipe all parts, and clean all ports, passages, and inner parts with compressed air.

3. Assemble in the reverse order of disassembly.

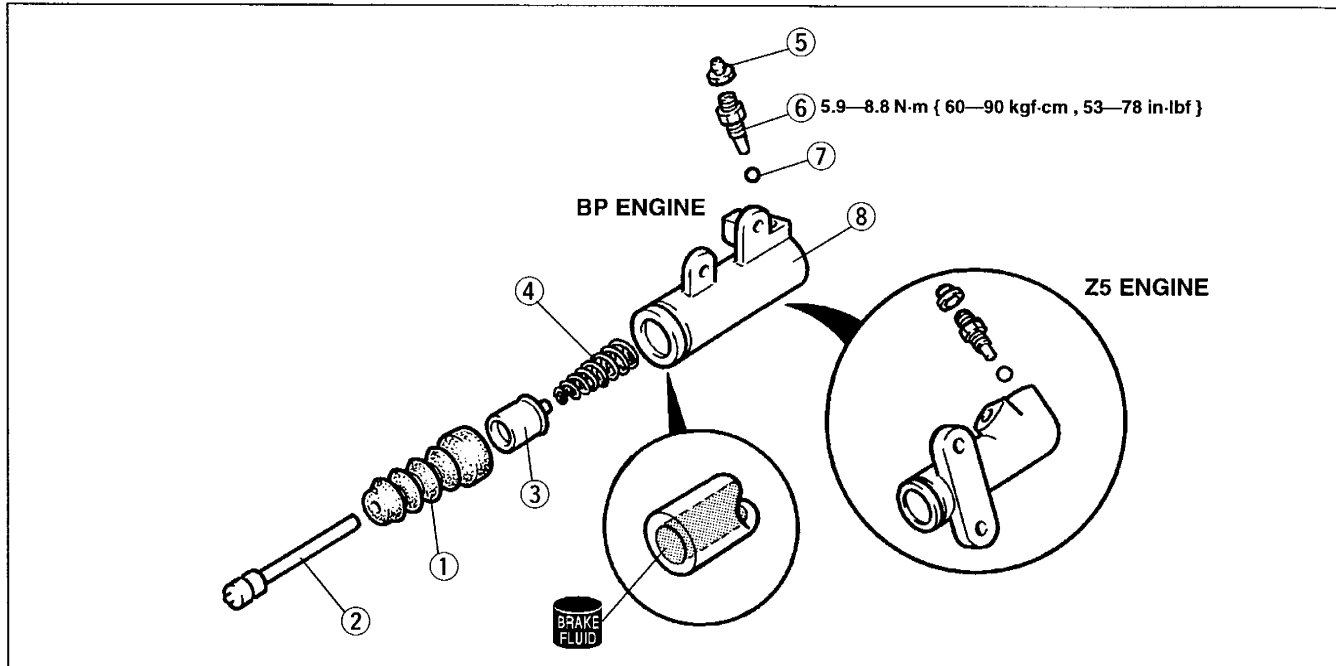





- | | |
|----------------------------|---------------------------------|
| 1. Boot | 5. Bleeder cap |
| 2. Push rod | 6. Bleeder screw |
| 3. Piston and cup assembly | 7. Steel ball |
| 4. Spring | 8. Clutch release cylinder body |

CLUTCH UNIT

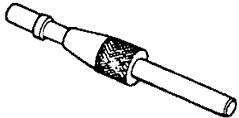
PREPARATION

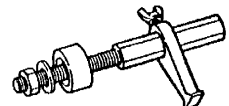
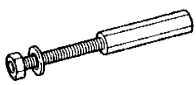
SST

<p>49 SE01 310A</p> <p>Centering tool, clutch disc</p> 	<p>For support of clutch disc</p>	<p>49 1285 071</p> <p>Puller, bearing</p> 	<p>For removal of pilot bearing</p>
<p>49 1285 073</p> <p>Chuck (Part of 49 1285 071)</p> 	<p>For removal of pilot bearing</p>	<p>49 E011 1A0</p> <p>Brake, ring gear</p> 	<p>For prevention of engine rotation</p>
<p>49 E011 103</p> <p>Shaft (Part of 49 E011 1A0)</p> 	<p>For prevention of engine rotation</p>	<p>49 E011 105</p> <p>Stopper (Part of 49 E011 1A0)</p> 	<p>For prevention of engine rotation</p>
<p>49 E011 104</p> <p>Collar (Part of 49 E011 1A0)</p> 	<p>For prevention of engine rotation</p>	<p>—</p>	<p>—</p>

H

REMOVAL / INSTALLATION

1. Remove in the order shown in the figure, referring to **Removal Note**.
2. Install in the reverse order of removal, referring to **Installation Note**.

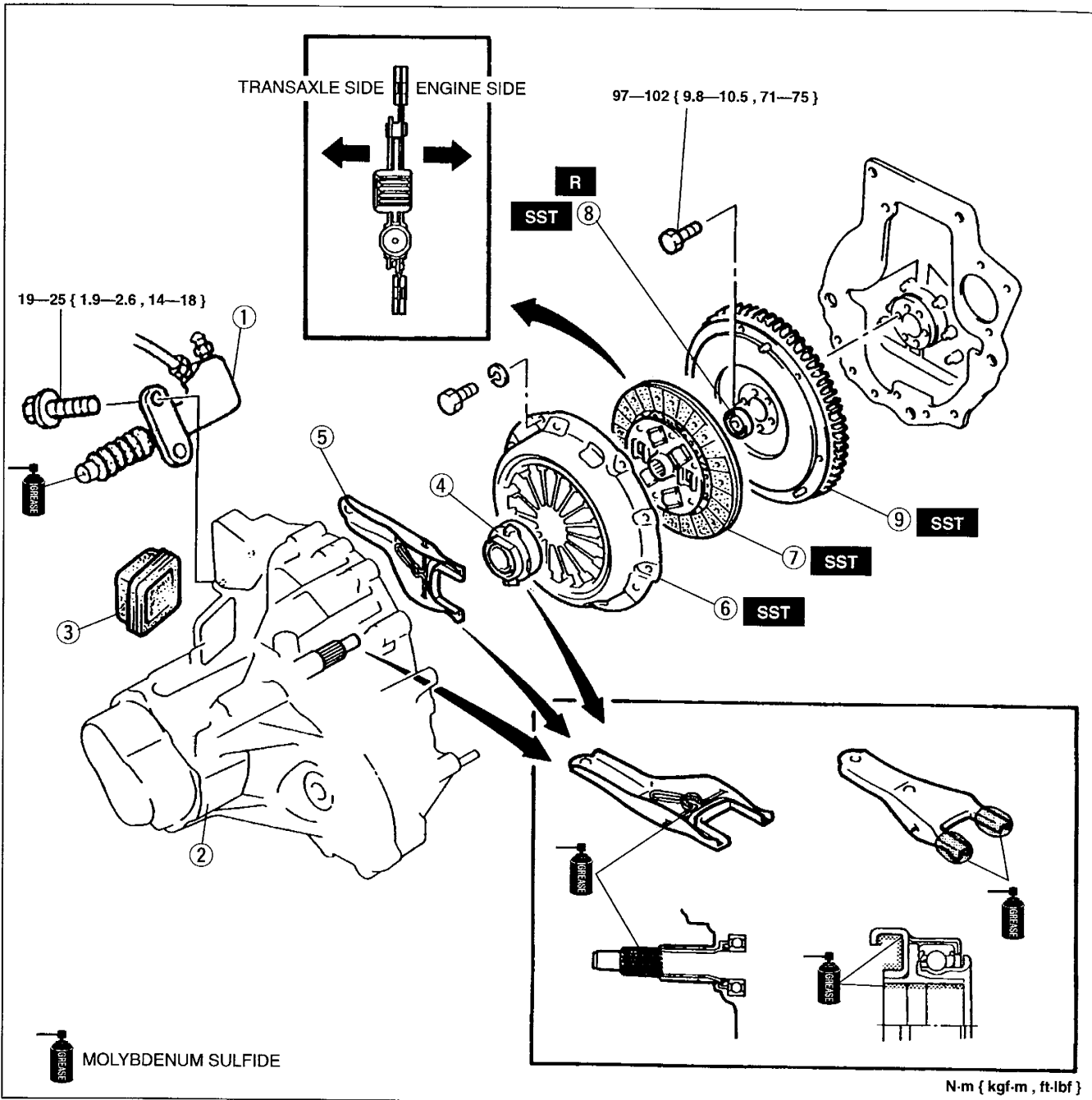

- | | |
|----------------------------|----------------|
| 1. Clutch release cylinder | |
| 2. Transaxle | |
| Service | section J1, J2 |
| 3. Boot | |
| 4. Clutch release collar | |
| Inspection | page H-14 |
| 5. Clutch release fork | |
| 6. Clutch cover | |
| Removal Note | page H-11 |
| Inspection | page H-13 |
| Installation Note | page H-12 |

- | | |
|-------------------------|-----------|
| 7. Clutch disc | |
| Removal Note | page H-11 |
| Inspection | page H-13 |
| Installation Note | page H-12 |
| 8. Pilot bearing | |
| Inspection | page H-14 |
| Removal Note | page H-11 |
| Installation Note | page H-11 |
| 9. Flywheel | |
| Removal Note | page H-11 |
| Inspection | page H-14 |
| Installation Note | page H-11 |

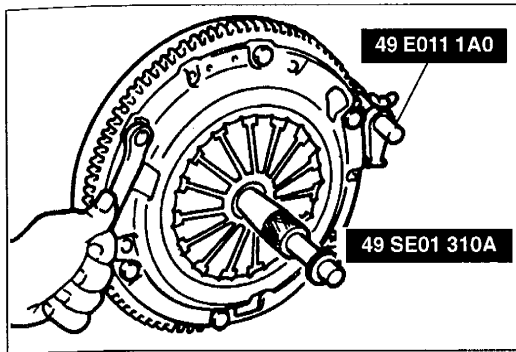

Removal Note Clutch cover and clutch disc

1. Install the **SSTs**.
2. Loosen each bolt one turn at a time in a crisscross pattern until the spring tension is released.
3. Remove the clutch cover and disc.

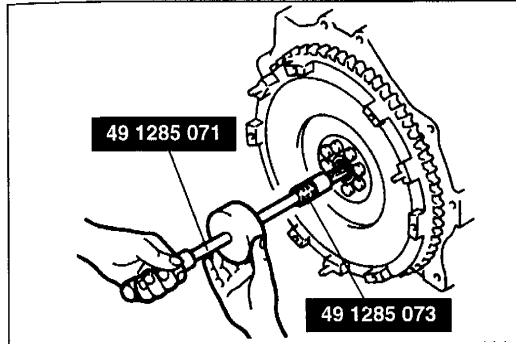

Pilot bearing

Note

- The pilot bearing does not need to be removed unless you are replacing it.

Use the **SSTs** to remove the pilot bearing.

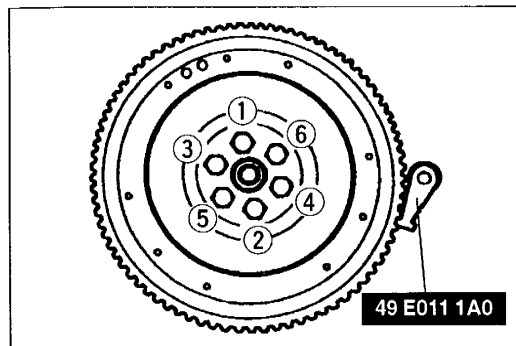

Flywheel

1. Hold the flywheel by using the **SST**.
2. Remove the bolts evenly and gradually in the pattern shown.
3. Remove the flywheel.
4. Inspect for oil leakage from the crankshaft rear oil seal. If there is any such leakage or if the oil seal is damaged, refer to section B and replace the crankshaft oil seal.

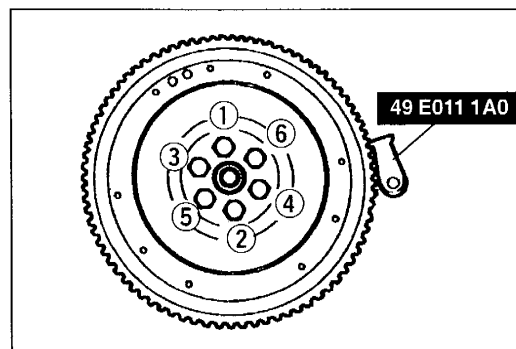

Installation Note

Flywheel

1. Install the flywheel to the crankshaft.
2. Hand-tighten the flywheel installation bolts.
3. Install the **SST** to the flywheel.
4. Tighten the flywheel installation bolts in the pattern shown in the figure.

Tightening torque:

97—102 N·m { 9.8—10.5 kgf·m , 71—75 ft·lbf }

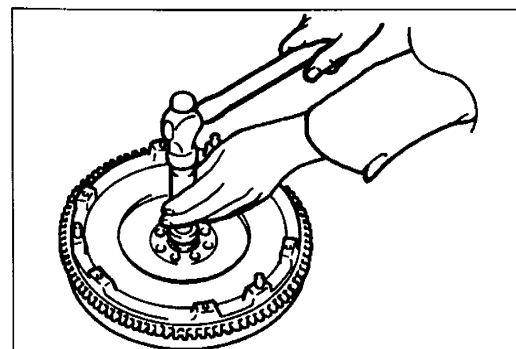

Pilot bearing

Install a new pilot bearing by using a suitable pipe.

Pipe outer diameter: 35.0 mm { 1.38 in }

Bearing installation depth:
0—0.4 mm { 0—0.016 in }

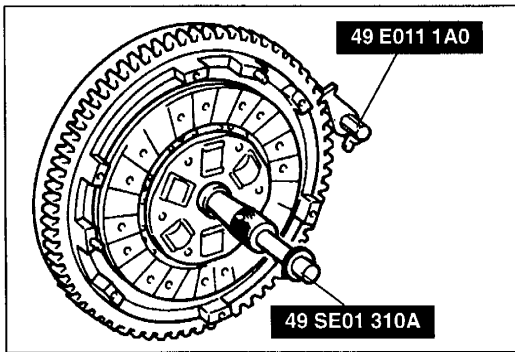
**Clutch disc**

Hold the clutch disc in position by using the **SSTs**.

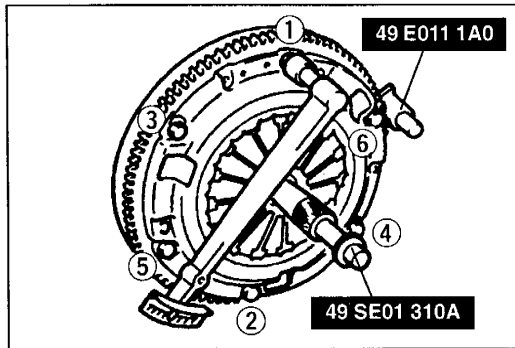
**Clutch cover**

1. Install the **SSTs**.
2. Tighten the bolts evenly and gradually in the pattern shown.

Tightening torque:

18—26 N·m { 1.8—2.7 kgf·m , 14—19 ft·lbf }

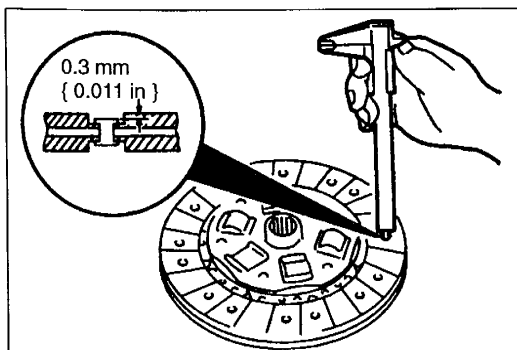
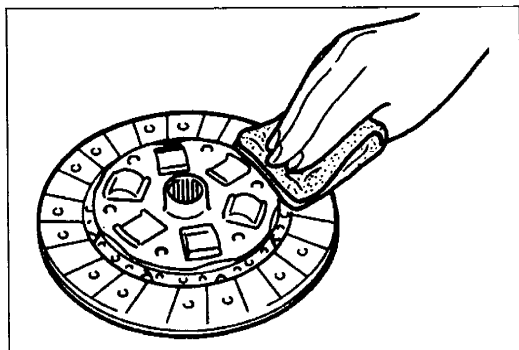
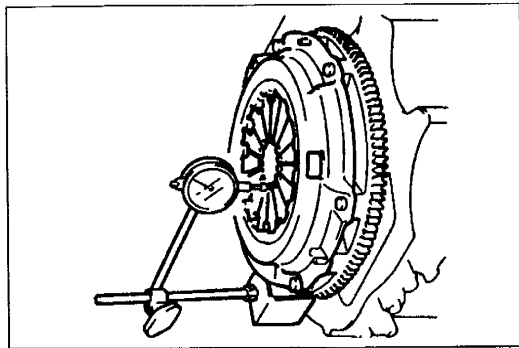
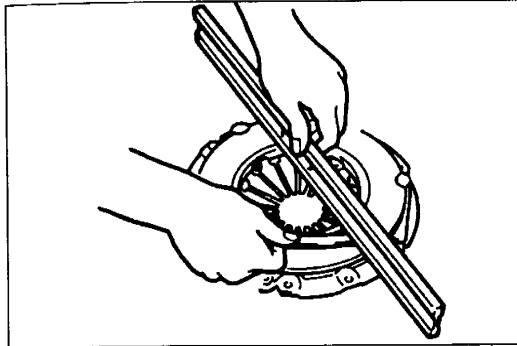
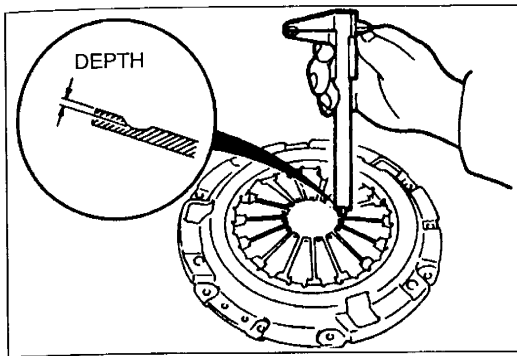

CLUTCH COVER

INSPECTION

1. Measure the wear of the diaphragm spring fingers.

Depth: 0.5 mm { 0.020 in } max.

2. Measure the flatness of the pressure plate surface by using a straightedge and a feeler gauge as shown in the figure.

Maximum clearance: 0.5 mm { 0.020 in }

Note

- When checking the diaphragm spring fingers, mount a dial indicator on the cylinder block.

3. Rotate the flywheel and check for misaligned diaphragm spring fingers.

Misalignment: 0.6 mm { 0.0236 in } max.

4. Replace the clutch cover if not as specified.

CLUTCH DISC

INSPECTION

1. Inspect the contact surface of the clutch disc for scoring, cracks, burning, and oil contamination.
2. Remove minor scoring or burning with emery paper. Repair if scoring or burning is major. Replace if cracked or oil-soaked.
3. Inspect for loose facing rivets and dampers. Replace the clutch disc if either is loose.

4. Using vernier calipers, measure the thickness of the lining at a rivet head on both sides. Replace the clutch disc if its thickness is less than the minimum.

Thickness: 0.3 mm { 0.012 in } min.

H CLUTCH DISC, CLUTCH RELEASE COLLAR, PILOT BEARING, FLYWHEEL

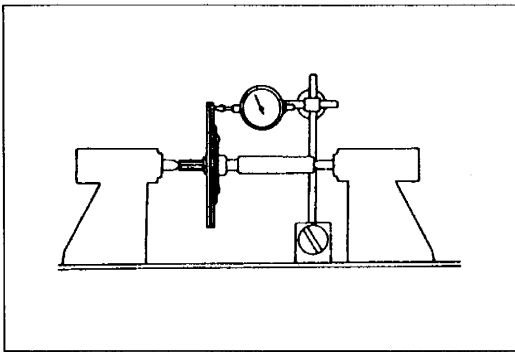

5. Measure the clutch disc runout with a dial indicator. Replace the clutch disc if runout is excessive.

Runout: 0.7 mm { 0.0276 in } max.

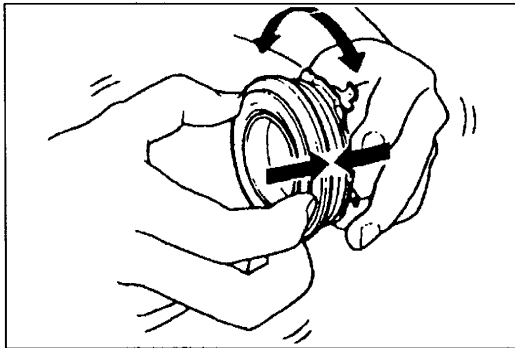

CLUTCH RELEASE COLLAR

INSPECTION

Caution

- Cleaning the clutch release collar with cleaning fluids or a steam cleaner can wash the grease out of the sealed bearing.

1. Turn the collar while applying force in the axial direction.
2. If the collar sticks or has excessive resistance, replace it.

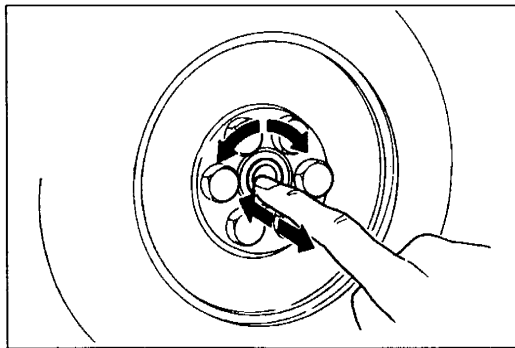

PILOT BEARING

INSPECTION

1. Without removing the pilot bearing from the flywheel, turn the bearing while applying force in the axial direction.
2. If the bearing sticks or has excessive resistance, replace it.

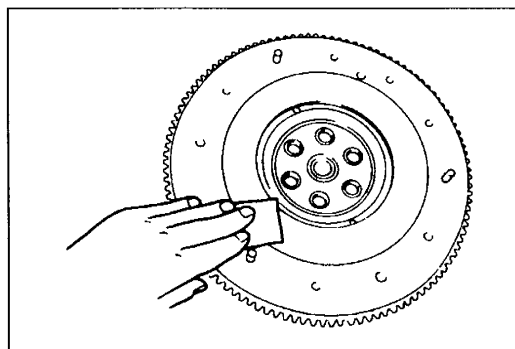

FLYWHEEL

INSPECTION

1. Inspect the contact surface for scoring, cracks, and burning.
2. Remove minor scoring or burning with emery paper. Repair if scoring or burning is major; replace if cracked.

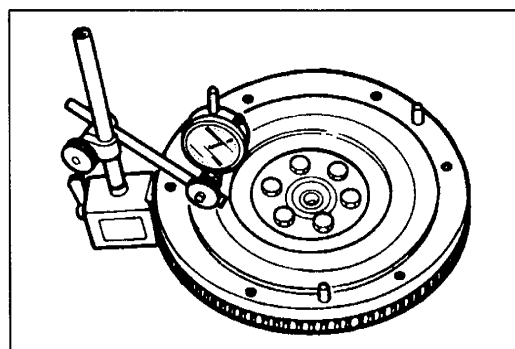

3. Inspect the ring gear teeth for wear and damage. If necessary, replace the ring gear.
4. Install a dial indicator on the cylinder block.
5. Measure the flywheel runout with the dial indicator. Replace the flywheel if runout is excessive.

Runout: 0.2 mm { 0.0079 in } max.

Before beginning any service procedure, refer to section T1 of this manual for air bag system service warnings.

MANUAL TRANSAXLE (F25M-R)

TRANSAXLE OIL	J-2
INSPECTION	J-2
REPLACEMENT	J-2
OIL SEAL (DIFFERENTIAL)	J-3
PREPARATION	J-3
REPLACEMENT	J-3
OIL SEAL (CHANGE ROD ASSEMBLY)	J-3
REPLACEMENT	J-3
TRANSAXLE	J-5
PREPARATION	J-5
REMOVAL / INSTALLATION	J-6
SHIFT MECHANISM	J-9
DISASSEMBLY / ASSEMBLY	J-9

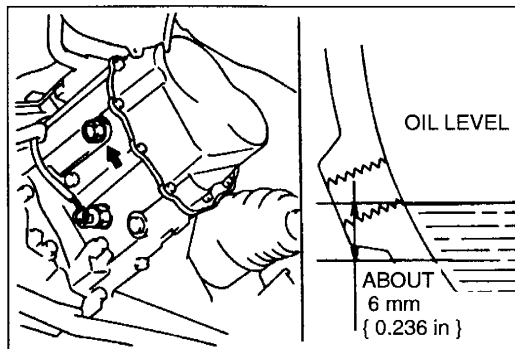
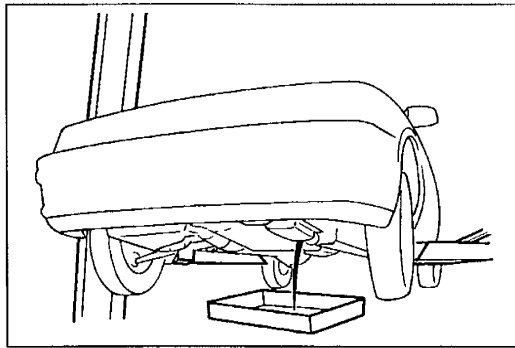
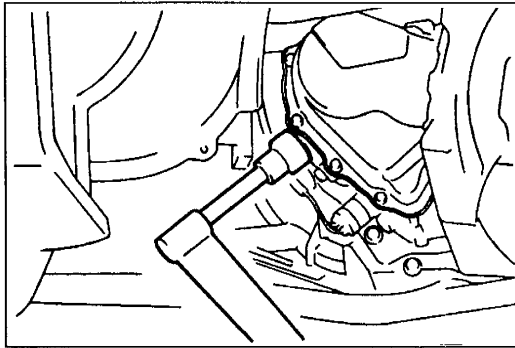
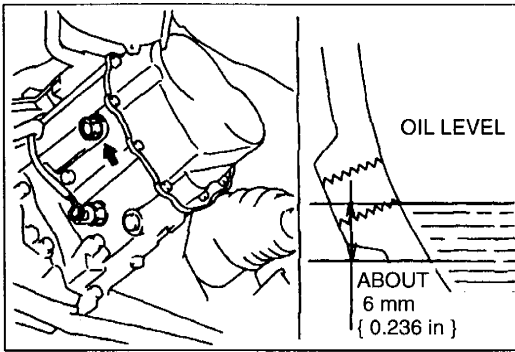

TRANSAXLE OIL

INSPECTION

Note

- Park the vehicle on level ground.

1. Remove the oil level plug and the washer.
2. Verify that the oil is near the bottom of the plug port.
3. If the oil level is low, add the specified amount and type of oil through the oil level plug hole.

Specified oil

Grade: API service GL-4 or GL-5

Viscosity: All season SAE 75W-90

Above 10 °C { 50 °F } SAE 80W-90

4. Install a new washer and the oil level plug.

Tightening torque:

40—58 N·m { 4.0—6.0 kgf·m , 29—43 ft·lbf }

REPLACEMENT

1. Remove the drain plug and the washer.
2. Drain the oil into a suitable container.
3. Install a new washer and the drain plug.

Tightening torque:

40—58 N·m { 4.0—6.0 kgf·m , 29—43 ft·lbf }

4. Remove the oil level plug and the washer. Add the specified amount and type of oil through the oil level plug hole until the level reaches the bottom of the oil level plug hole.

Specified oil

Grade: API service GL-4 or GL-5

Viscosity: All season SAE 75W-90

Above 10 °C { 50 °F } SAE 80W-90

Capacity: 2.68 L { 2.83 US qt , 2.36 Imp qt }

5. Install a new washer and the oil level plug.

Tightening torque:

40—58 N·m { 4.0—6.0 kgf·m , 29—43 ft·lbf }

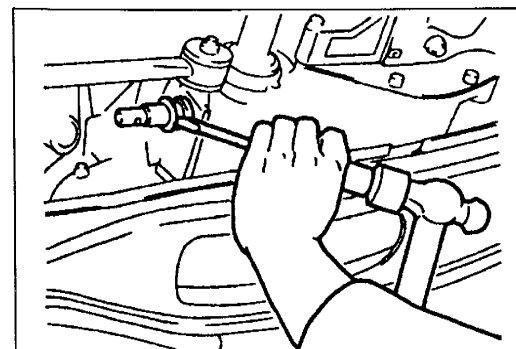
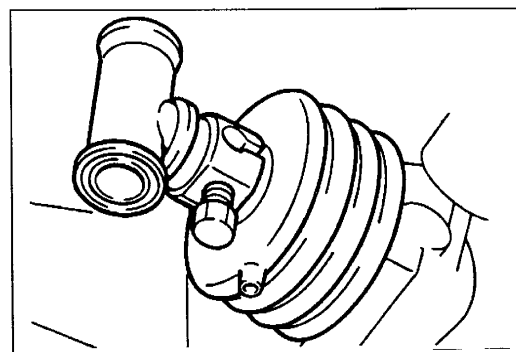
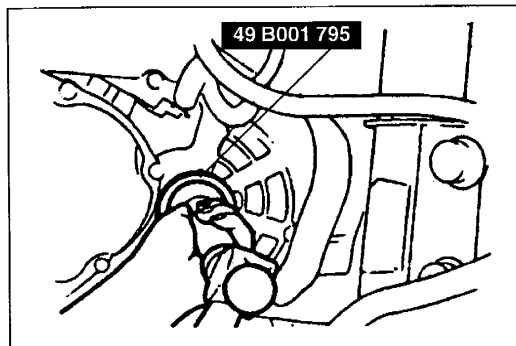
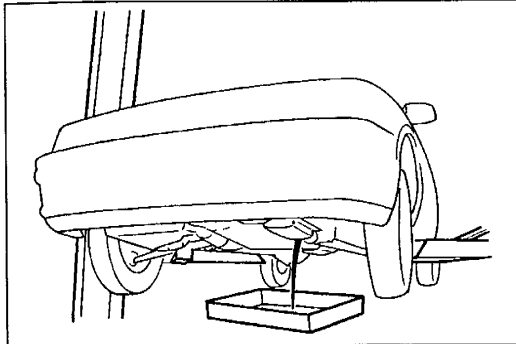
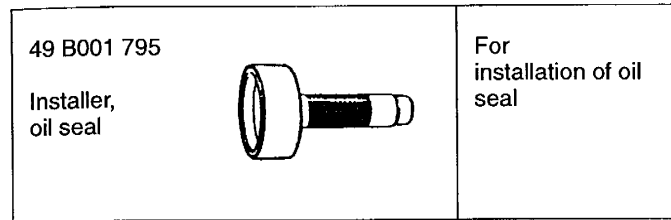
OIL SEAL (DIFFERENTIAL)**PREPARATION****SST****REPLACEMENT**

1. Drain the transaxle oil. (Refer to page J-2.)
2. Separate the drive shaft and joint shaft from the transaxle. (Refer to section M.)
3. Remove the oil seal by using a screwdriver.

4. Using the **SST** and a hammer, tap the new oil seal in evenly until the **SST** contacts the transaxle case.
5. Coat the oil seal lip with transaxle oil.
6. Insert the drive shaft and joint shaft to the transaxle. (Refer to section M.)
7. Add the specified amount and type of transaxle oil. (Refer to page J-2.)

OIL SEAL (CHANGE ROD ASSEMBLY)**REPLACEMENT**

1. Drain the transaxle oil. (Refer to page J-2.)
2. Remove the transverse member.
3. Disconnect the change control rod from the transaxle.
4. Remove the joint and boot from the change rod assembly.

5. Remove the oil seal by using a screwdriver.

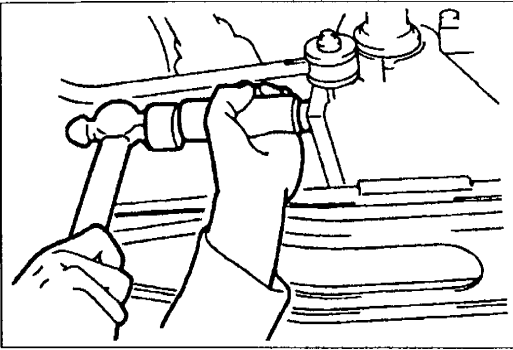

6. Apply the specified oil to the lip of the oil seal.
7. Install the new oil seal by using a suitable pipe.

Outer diameter of pipe: 26.0 mm { 1.02 in }

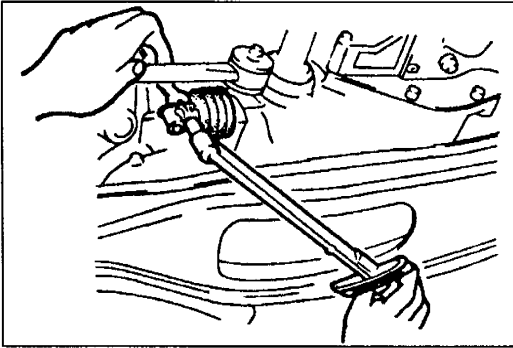

8. Position the boot hole downward, and install the boot onto the oil seal.
9. Install the joint to the change rod assembly.



Tightening torque:

16—22 N·m { 1.6—2.3 kgf·m , 12—16 ft·lbf }

10. Cover the change rod assembly with the boot hole facing downward.
11. Install the change control rod.
12. Install the transverse member.
13. Add the specified amount and type of transaxle oil.
(Refer to page J-2.)

TRANSAXLE

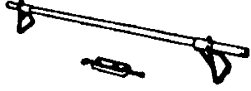
PREPARATION
SST

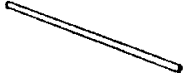
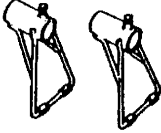
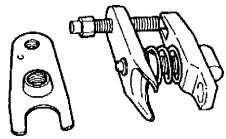
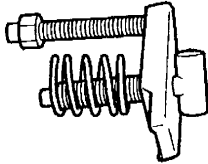
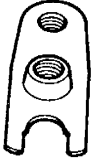
<p>49 G017 5A0</p> <p>Support, engine</p> 	<p>For support of engine</p>	<p>49 G017 503</p> <p>Hook (Part of 49 G017 5A0)</p> 	<p>For support of engine</p>
<p>49 G017 501</p> <p>Bar (Part of 49 G017 5A0)</p> 	<p>For support of engine</p>	<p>49 G017 502</p> <p>Support (Part of 49 G017 5A0)</p> 	<p>For support of engine</p>
<p>49 T028 3A0</p> <p>Puller set, ball joint</p> 	<p>For removal of tie-rod end</p>	<p>49 T028 303</p> <p>Body (Part of 49 T028 3A0)</p> 	<p>For removal of tie-rod end</p>
<p>49 T028 304</p> <p>Attachment (Part of 49 T028 3A0)</p> 	<p>For removal of tie-rod end</p>	<p>—</p>	<p>—</p>

J

REMOVAL / INSTALLATION

1. Drain the transaxle oil. (Refer to page J-2.)
2. Remove in the order shown in the figure, referring to **Removal Note**.
3. Install in the reverse order of removal, referring to **Installation Note**.
4. Add the specified amount and type of transaxle oil. (Refer to page J-2.)
5. Warm up the engine and transaxle, inspect for oil leakage, and check transaxle operation.

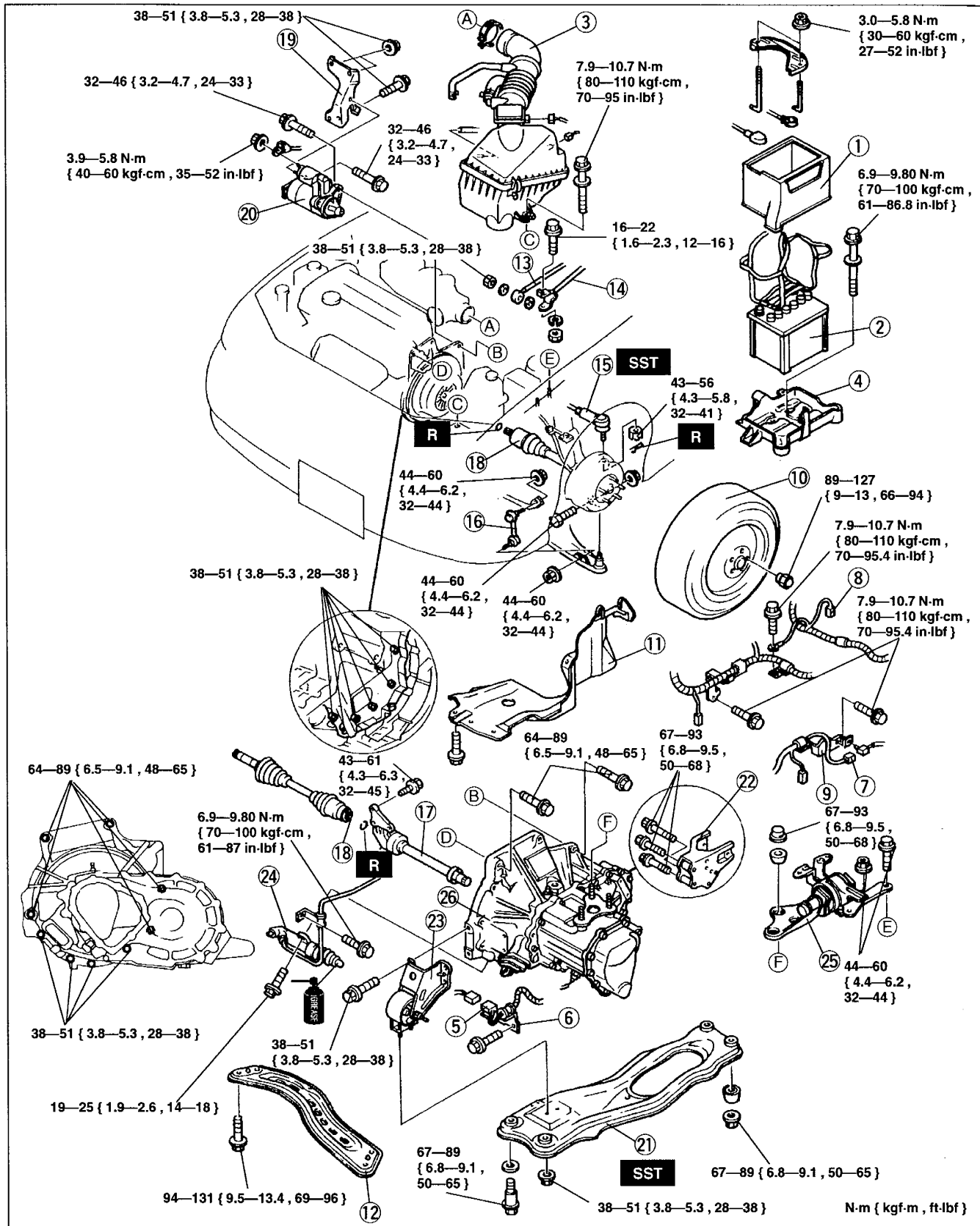

- | | |
|---|----------------------------------|
| 1. Battery box | 18. Drive shafts |
| 2. Battery | Service section M |
| 3. Air cleaner assembly | 19. Intake manifold bracket |
| 4. Battery carrier | 20. Starter |
| 5. Back-up light switch connector | 21. Engine mounting member |
| 6. Back-up light switch connector bracket | Removal Note below |
| 7. Neutral switch connector | Installation Note page J-8 |
| 8. Vehicle speedometer sensor connector | 22. No.1 engine mount |
| 9. Harness bracket | Installation Note page J-8 |
| 10. Wheel and tire | 23. No.2 engine mount |
| 11. Splash shield | Installation Note page J-8 |
| 12. Transverse member | 24. Clutch release cylinder |
| 13. Extension bar | 25. No.4 engine mount |
| 14. Change control rod | 26. Transaxle |
| 15. Tie-rod end | Removal Note below |
| Service section N | Installation Note page J-8 |
| 16. Stabilizer control link | |
| 17. Joint shaft | |
| Service section M | |

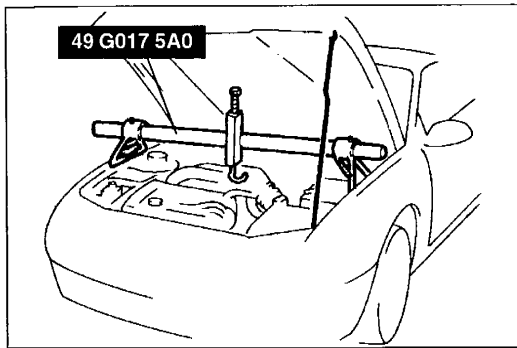

Removal Note
Engine mounting member

1. Suspend the engine by using the **SST**.
2. Remove the engine mounting member.

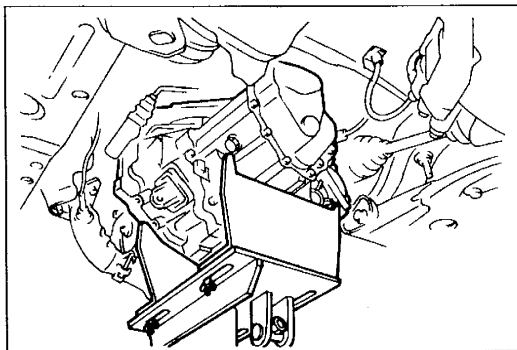

Transaxle

1. Loosen the **SST** (engine support) and lean the engine toward the transaxle.
2. Support the transaxle on a jack.
3. Remove the transaxle bolts.
4. Remove the transaxle.

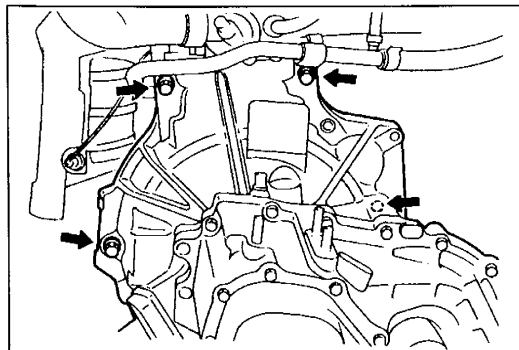

Warning

- Do not allow the transaxle to fall from the jack.

5. Remove the transaxle mounting bolts.
6. Remove the transaxle.

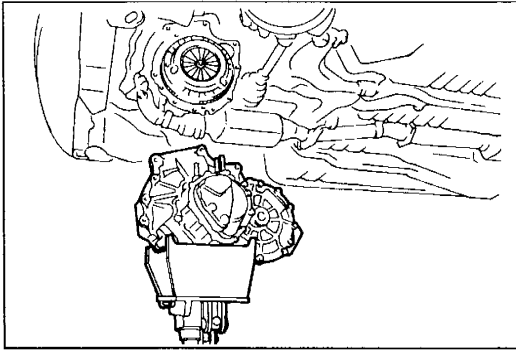

Installation Note

Transaxle

1. Set the transaxle on a jack and carefully lift into place.
2. Install the transaxle mounting bolts.

Tightening torque:

64—89 N·m { 6.5—9.1 kgf·m , 48—65 ft·lbf }

3. Hand-tighten the No.4 engine mount bolts and nuts.

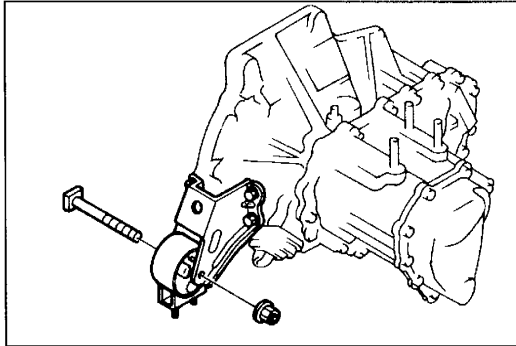

No.2 engine mount

Hand-tighten the No.2 engine mount rubber nut.

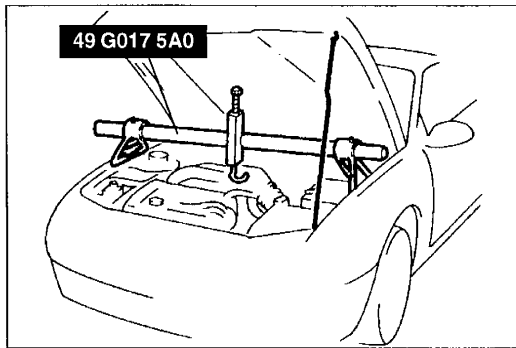

No.1 engine mount

Caution

- Misaligning the bolts will cause damage to the bolt holes.

1. Use the **SST** (engine support) to make sure the transaxle bolt holes and No.1 engine mount meet evenly.
2. After the 3 bolts are set in the holes, tighten the bolts to the specified torque.

Tightening torque:

67—93 N·m { 6.8—9.5 kgf·m , 50—68 ft·lbf }

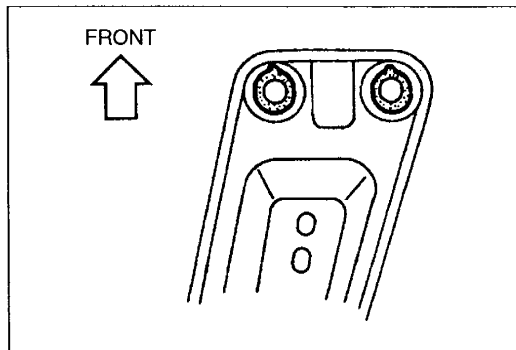

Engine mounting member

Note

- Verify that the engine mount rubbers are installed as shown.
- Put the No.1 engine mount stud bolts in the installation holes when installing the engine mounting member.

1. Install the bolts and nuts as shown.

Tightening torque

A: 67—89 N·m { 6.8—9.1 kgf·m , 50—65 ft·lbf }

B: 38—51 N·m { 3.8—5.3 kgf·m , 28—38 ft·lbf }

2. Tighten the No.2 engine mount rubber nut.

Tightening torque:

67—93 N·m { 6.8—9.5 kgf·m , 50—68 ft·lbf }

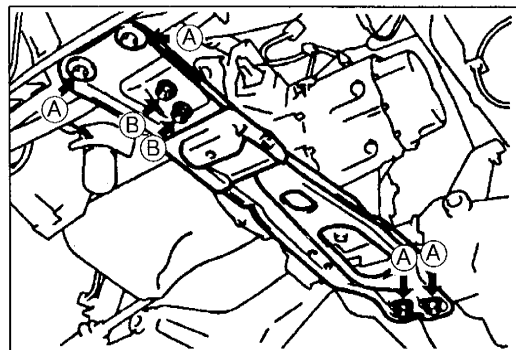

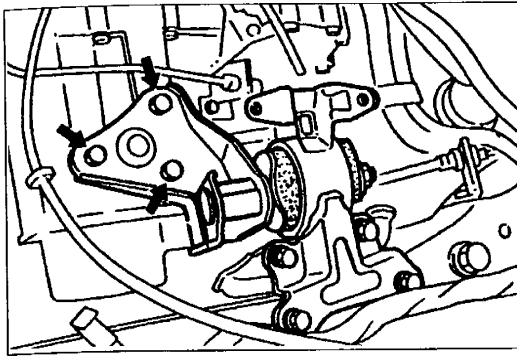

3. Tighten the No.4 engine mount bolts and nuts.

Tightening torque:

67—93 N·m { 6.8—9.5 kgf·m , 50—68 ft·lbf }

4. Remove the SST (engine support).

SHIFT MECHANISM

DISASSEMBLY / ASSEMBLY

1. Disassemble in the order shown in the figure.
2. Inspect all parts and repair or replace as necessary.
3. Assemble in the reverse order of disassembly.

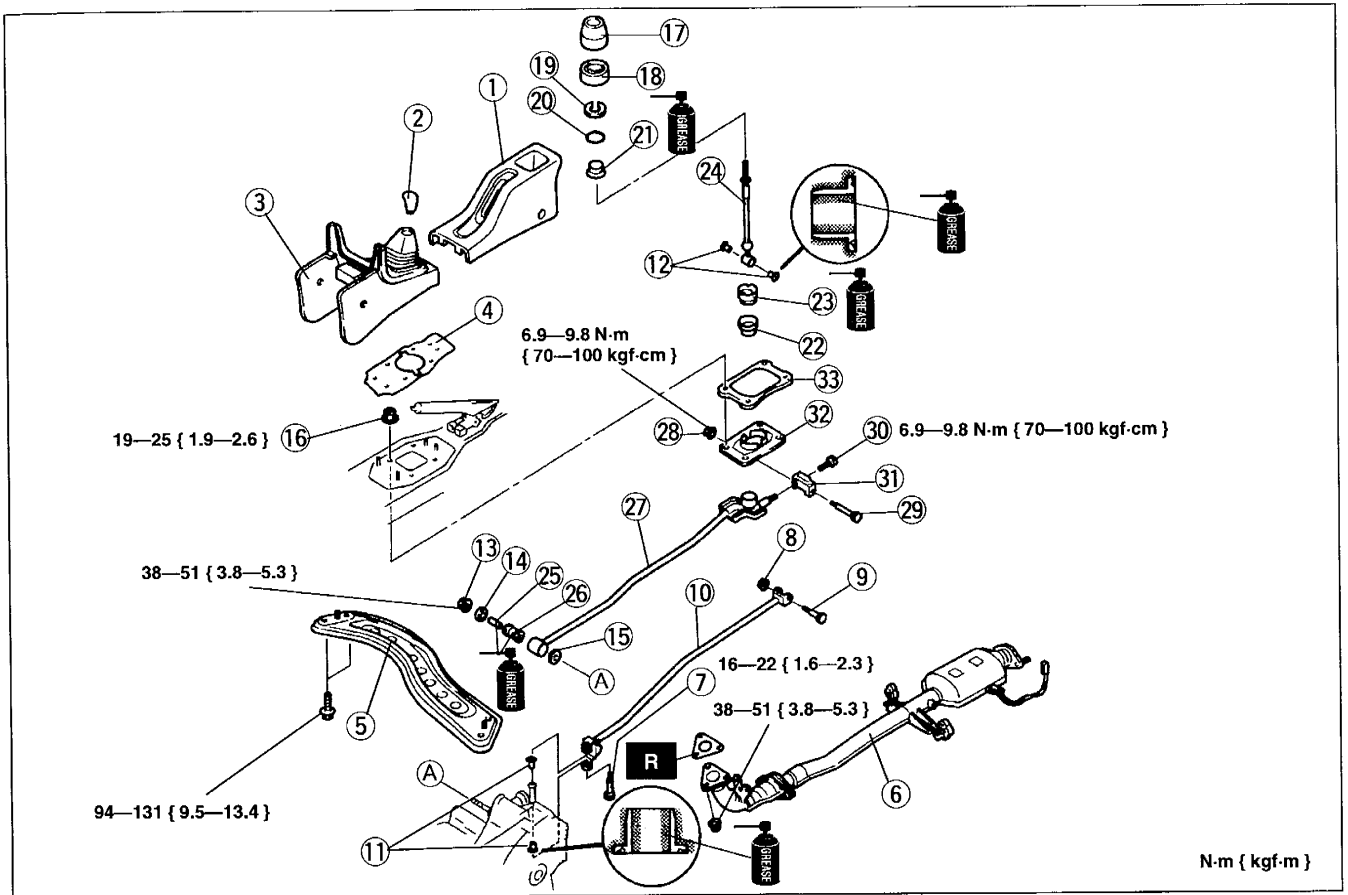

- 1. Rear console
- 2. Shift lever knob
- 3. Front console
- 4. Insulator
- 5. Transverse member
- 6. Front exhaust pipe
- 7. Bolt
- 8. Nut
- 9. Bolt
- 10. Control rod
- 11. Bushings

- 12. Bushings
- 13. Nut
- 14. Washer
- 15. Washer
- 16. Nut (lever bracket)
- 17. Assist boot
- 18. Mounting rubber boot
- 19. Retaining ring
- 20. O-ring
- 21. Upper ball seat
- 22. Boot

- 23. Lower ball seat
- 24. Gear shift lever
- 25. Pipe
- 26. Bushing
- 27. Extension bar
- 28. Nut
- 29. Bolt
- 30. Bolt
- 31. Rubber mount
- 32. Lever bracket
- 33. Insulator



Before beginning any service procedure, refer to section T1 of this manual for air bag system service warnings.

AUTOMATIC TRANSAXLE (FA4A-EL)

<p>MECHANICAL SYSTEM TEST K- 2</p> <p> PREPARATION K- 2</p> <p> MECHANICAL SYSTEM TEST</p> <p> PREPARATION K- 2</p> <p> LINE PRESSURE TEST K- 3</p> <p> STALL TEST K- 5</p> <p> TIME LAG TEST K- 6</p> <p>ROAD TEST K- 8</p> <p> ROAD TEST PREPARATION K- 8</p> <p> SHIFT DIAGRAM K- 8</p> <p> D RANGE TEST K- 9</p> <p> 2 RANGE TEST K-10</p> <p> 1 RANGE TEST K-10</p> <p> P POSITION TEST K-10</p> <p>AUTOMATIC TRANSAXLE FLUID</p> <p> (ATF) K-10</p> <p> ATF K-10</p> <p>THROTTLE CABLE K-12</p> <p> PREPARATION K-12</p> <p> THROTTLE CABLE K-12</p> <p>ELECTRICAL SIGNAL INSPECTION . K-16</p> <p> PREPARATION K-16</p> <p> ELECTRICAL SIGNAL</p> <p> INSPECTION K-17</p> <p>ELECTRICAL SYSTEM</p> <p> COMPONENTS K-24</p> <p> O/D OFF SWITCH K-24</p> <p> TRANSAXLE RANGE SWITCH K-25</p> <p> TRANSAXLE FLUID TEMPERATURE</p> <p> SENSOR K-27</p> <p> INPUT/TURBINE SPEED SENSOR . K-29</p> <p> VEHICLE SPEEDOMETER</p> <p> SENSOR K-29</p> <p> SOLENOID VALVES K-30</p> <p> O/D OFF INDICATOR LIGHT K-32</p> <p> POWERTRAIN CONTROL</p> <p> MODULE K-33</p>	<p>TRANSAXLE K-34</p> <p> TRANSAXLE UNIT</p> <p> (REMOVAL / INSTALLATION) K-34</p> <p> OIL SEAL (TRANSAXLE) K-42</p> <p> CONTROL VALVE BODY (ON-VEHICLE</p> <p> REMOVAL / INSTALLATION) K-43</p> <p>OIL COOLER K-45</p> <p> OIL COOLER K-45</p> <p>DRIVE PLATE K-47</p> <p> PREPARATION K-47</p> <p> DRIVE PLATE K-47</p> <p>SHIFT MECHANISM K-49</p> <p> SHIFT-LOCK K-49</p> <p> EMERGENCY OVERRIDE</p> <p> BUTTON K-49</p> <p> KEY INTERLOCK K-49</p> <p> P POSITION SWITCH K-50</p> <p> SHIFT-LOCK ACTUATOR K-51</p> <p> SELECTOR LEVER K-52</p> <p>ON-BOARD DIAGNOSTIC SYSTEM .. K-59</p> <p> PREPARATION K-59</p> <p> DIAGNOSTIC TROUBLE CODE K-59</p> <p>TROUBLESHOOTING K-74</p> <p> TROUBLESHOOTING NOTES K-74</p> <p> DIAGNOSTIC INDEX K-77</p> <p> QUICK DIAGNOSIS CHART K-78</p> <p> BASIC INSPECTION K-82</p> <p> SYMPTOM TROUBLESHOOTING .. K-83</p>
---	--

MECHANICAL SYSTEM TEST

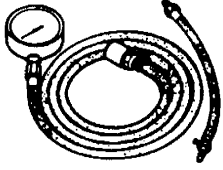
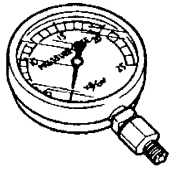
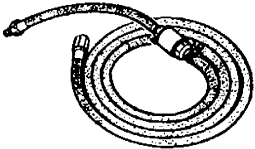
PREPARATION SST

<p>49 0378 400B</p> <p>Oil pressure gauge set</p> 	<p>For oil pressure test</p>	<p>49 B019 902</p> <p>Oil pressure gauge (Part of 49 0378 400B)</p> 	<p>For oil pressure test</p>
<p>49 B019 903</p> <p>Hose (Part of 49 0378 400B)</p> 	<p>For oil pressure test</p>	<p>49 B019 901</p> <p>Oil pressure gauge</p> 	<p>For oil pressure test</p>
<p>49 H019 002</p> <p>Adapter</p> 	<p>For oil pressure test</p>	<p>—</p>	<p>—</p>

MECHANICAL SYSTEM TEST PREPARATION

1. Engage the parking brake and use wheel chocks at the front and rear of the wheels.
2. Check the engine coolant (Refer to section E.)
3. Check the engine oil (Refer to section B.)
4. Check the ATF levels (Refer to page K-10.)
5. Check the idle speed and ignition timing in P position (Refer to section F1, F2.)

LINE PRESSURE TEST Procedure

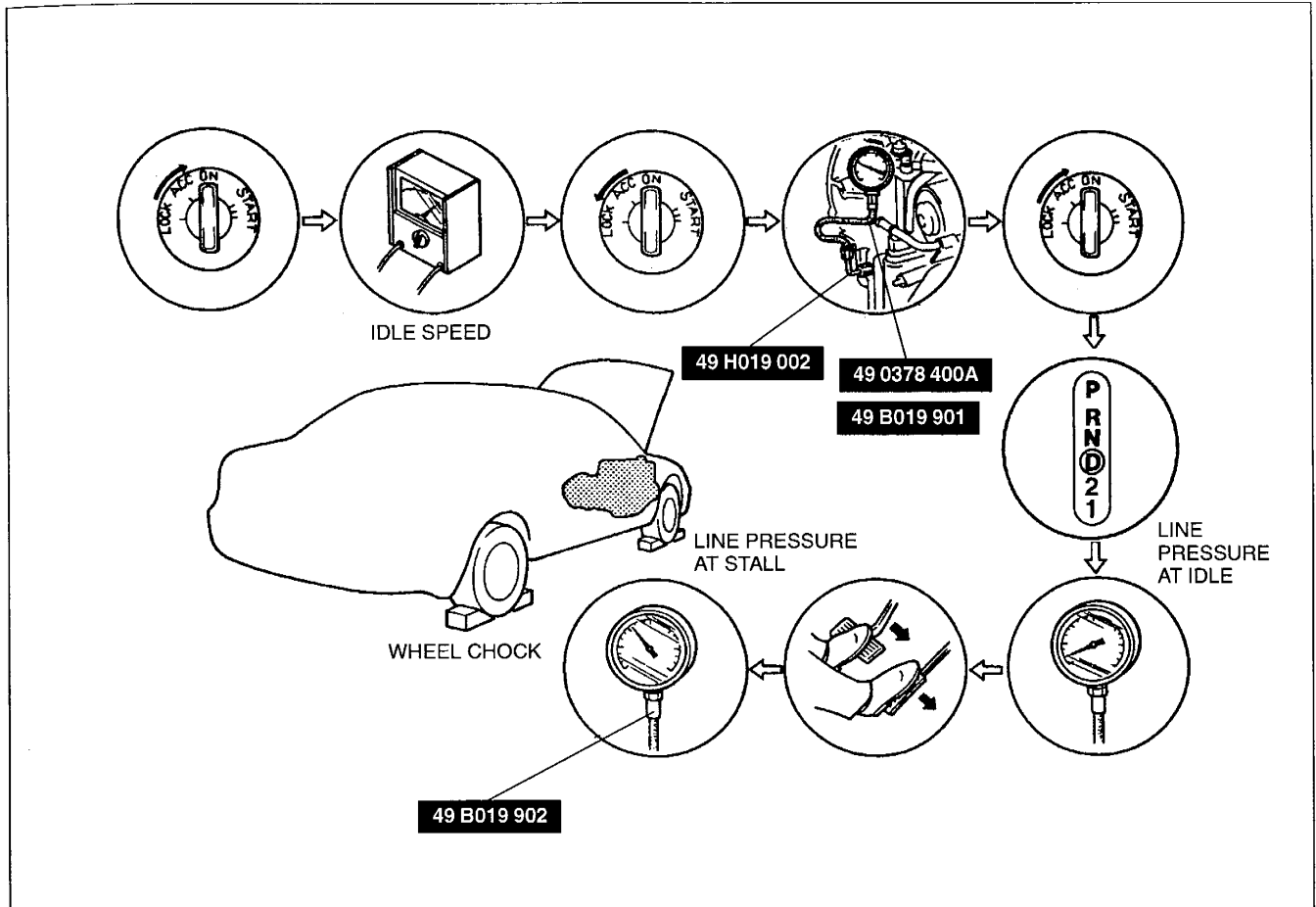

Warning

- **Draining the ATF when it is hot is dangerous. Hot ATF can shoot out when the square-head plug is removed, causing burns and serious injury. Wait until the transaxle and ATF are cool before draining the ATF.**

1. Connect the SSTs (49 H019 002, 49 B019 901, and 49 B019 903) to the line pressure inspection port.
2. Shift the selector lever to D range and read the line pressure at idle.
3. Connect the SST (49 B019 902) to the line pressure inspection port.

Caution

- **If the accelerator pedal is pressed for longer than 5 seconds while the brake pedal is depressed, the transaxle could be damaged. Therefore, do steps 4 and 5 within 5 seconds of each other.**

4. Firmly depress the brake pedal with the left foot, and then gradually depress the accelerator pedal with the right.
5. When the engine speed no longer increases, quickly read the line pressure and release the accelerator.
6. Shift the selector to N position and let the engine idle for 1 minute or more to cool the ATF.
7. Read the line pressure at idle and at the engine stall speed for the remaining ranges in the same manner.
 - (1) 2 range
 - (2) 1 range
 - (3) R position
8. Shift the selector lever to D range and disconnect the solenoid valve connector. (Refer to page K-34.)
9. Read the line pressure at idle and at the engine stall speed in the same manner.
10. Connect the solenoid connector. (Refer to page K-34.)

Specified line pressure:

Range/Position	Line pressure kPa { kgf/cm ² , psi }			
	Idle		Stall	
	Z5	BP	Z5	BP
D, D (solenoid connector disconnected), 2, 1	430—550 { 4.3—5.7 , 62—81 }		920—1,040 { 9.3—10.7 , 140—152 }	
R	730—870 { 7.4—8.9 , 110—120 }		1,500—1,700 { 15.2—17.4 , 217—247 }	

11. Install a new square head plug in the line pressure inspection port.

Tightening torque: 5.0—9.8 N·m { 50—100 kgf·cm , 44—86 in·lbf }

Evaluation of Line Pressure Test

Line pressure	Possible cause
Below specification in R position and all ranges	Worn oil pump Fluid leaking from oil pump, control valve body, or transaxle case Pressure regulator valve sticking Throttle cable misadjusted Throttle valve sticking Throttle modulator valve sticking
Below specification in D, 2, and 1 ranges	Fluid leaking from hydraulic circuit of forward clutch
Below specification in 2 range	Fluid leaking from hydraulic circuit of 2-4 brake band
Below specification in 1 range and R position	Fluid leaking from hydraulic circuit of low and reverse brake
Below specification in D range (solenoid connector disconnected)	Fluid leaking from hydraulic circuit of 3-4 clutch
Below specification in R position	Fluid leaking from hydraulic circuit of reverse clutch
Above specification in R position and all ranges	Throttle valve sticking Throttle modulator valve sticking Pressure regulator valve sticking Throttle cable misadjusted

STALL TEST Procedure

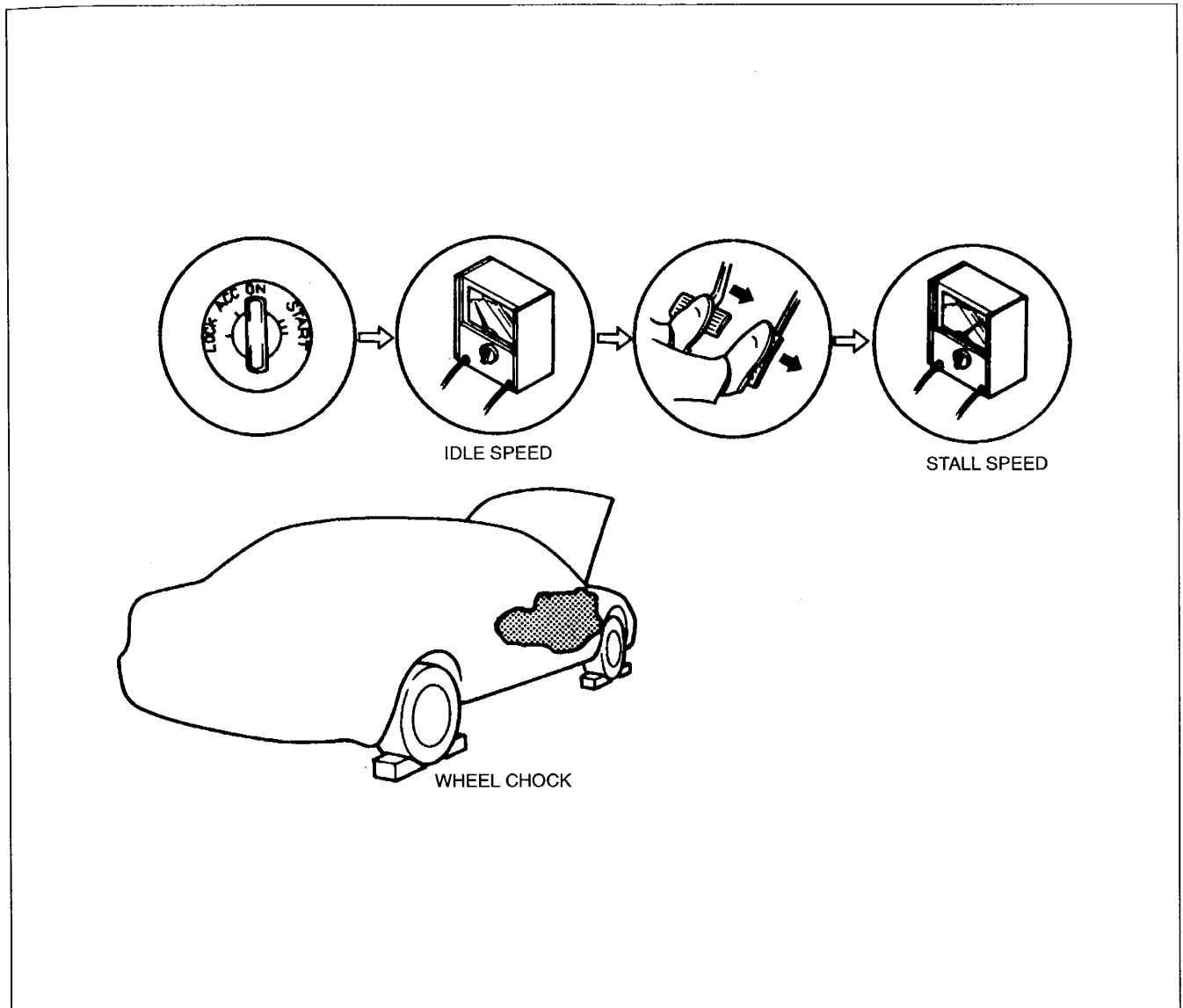

1. Shift the selector lever to D range.

Caution

- If the accelerator pedal is depressed for longer than 5 seconds while the brake pedal is depressed, the transaxle could be damaged. Therefore, do steps 2 and 3 within 5 seconds of each other.
2. Firmly depress the brake pedal with the left foot, and then gradually depress the accelerator pedal with the right.
 3. When the engine speed no longer increases, quickly read the engine speed and release the accelerator.
 4. Shift the selector to N position and let the engine idle for 1 minute or more to cool the ATF.
 5. Perform stall tests for the remaining ranges and position in the same manner.
 - (1) 2 range
 - (2) 1 range
 - (3) R position

Engine stall speed

Z5: 1,950—2,250 rpm
BP: 2,200—2,500 rpm

Evaluation of Stall Test

Condition		Possible Cause	
Above specification	In R position and all ranges	Insufficient line pressure	Worn oil pump
			Oil leakage from oil pump, control valve, and/or transaxle case
			Stuck pressure regulator valve
	In D range	Forward clutch slipping One-way clutch 1 slipping One-way clutch 2 slipping	
In 2 range	2-4 brake band slipping		
In R position	Low and reverse brake slipping Reverse clutch slipping Perform road test to determine whether problem is low and reverse brake or reverse clutch a) Engine braking felt in 1 range... Reverse clutch b) Engine braking not felt in 1 range ... Low and reverse brake		
Below specification in R position and all ranges		Engine out of tune	
		One-way clutch slipping within torque converter	

TIME LAG TEST Procedure

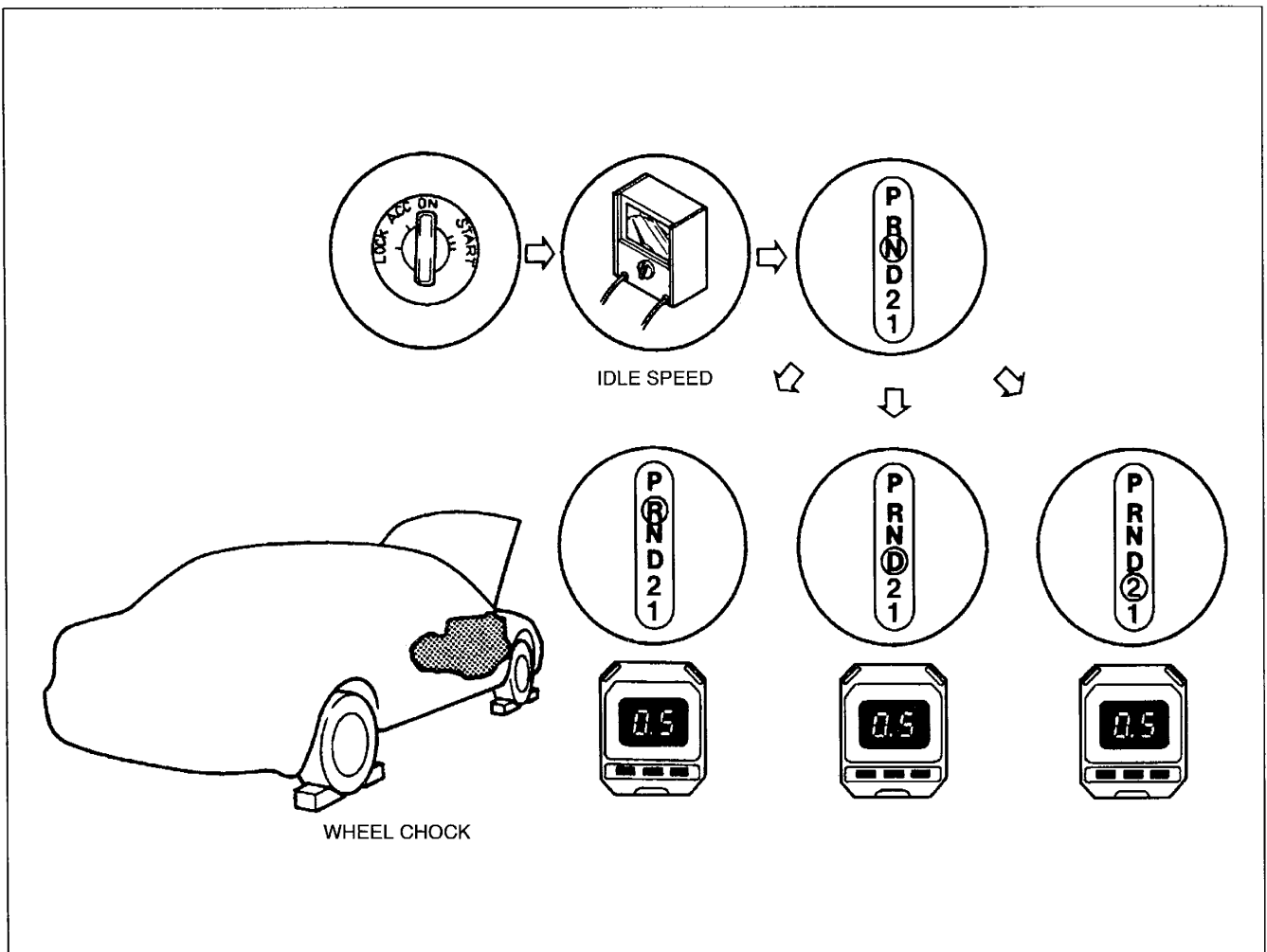

1. Shift the selector from N position to D range.
2. Use a stopwatch to measure the time it takes from shifting until shock is felt.
3. Shift the selector lever to N position and run the engine at idle speed for at least 1 minute.
4. Do the time lag test for the following shifts in the same manner. Make three measurements for each test and average the results.
5. While depressing the brake pedal, perform the test for the following shifts in the same manner.
 - (1) N position→D range
 - (2) N position→2 range
 - (3) N position→R position

Time lag:

- N position→D range ... approx. 0.5—0.6 seconds**
- N position→2 range ... approx. 0.5—0.7 seconds**
- N position→R position ... approx. 0.6—0.7 seconds**

Evaluation of Time Lag Test

Condition		Possible Cause
N position→D range shift	Above specification	Insufficient line pressure Forward clutch slipping One-way clutch 1 slipping One-way clutch 2 slipping
	Below specification	N-D accumulator not operating properly Excessive line pressure
N position→2 range shift	Above specification	Insufficient line pressure Forward clutch slipping 2-4 brake band slipping One-way clutch 1 slipping
	Below specification	1-2 accumulator not operating properly Excessive line pressure
N position→R position shift	Above specification	Insufficient line pressure Low and reverse brake slipping Reverse clutch slipping
	Below specification	N-R accumulator not operating properly Excessive line pressure

K

ROAD TEST

ROAD TEST PREPARATION

1. Check and correct as necessary, the engine coolant, engine oil, and ATF levels before testing.
2. Warm up the engine thoroughly to raise the ATF temperature to operating level (60—70 °C { 140—158 °F }).
3. Check the idle speed and ignition timing in P position. (Refer to section F1, F2.)

SHIFT DIAGRAM

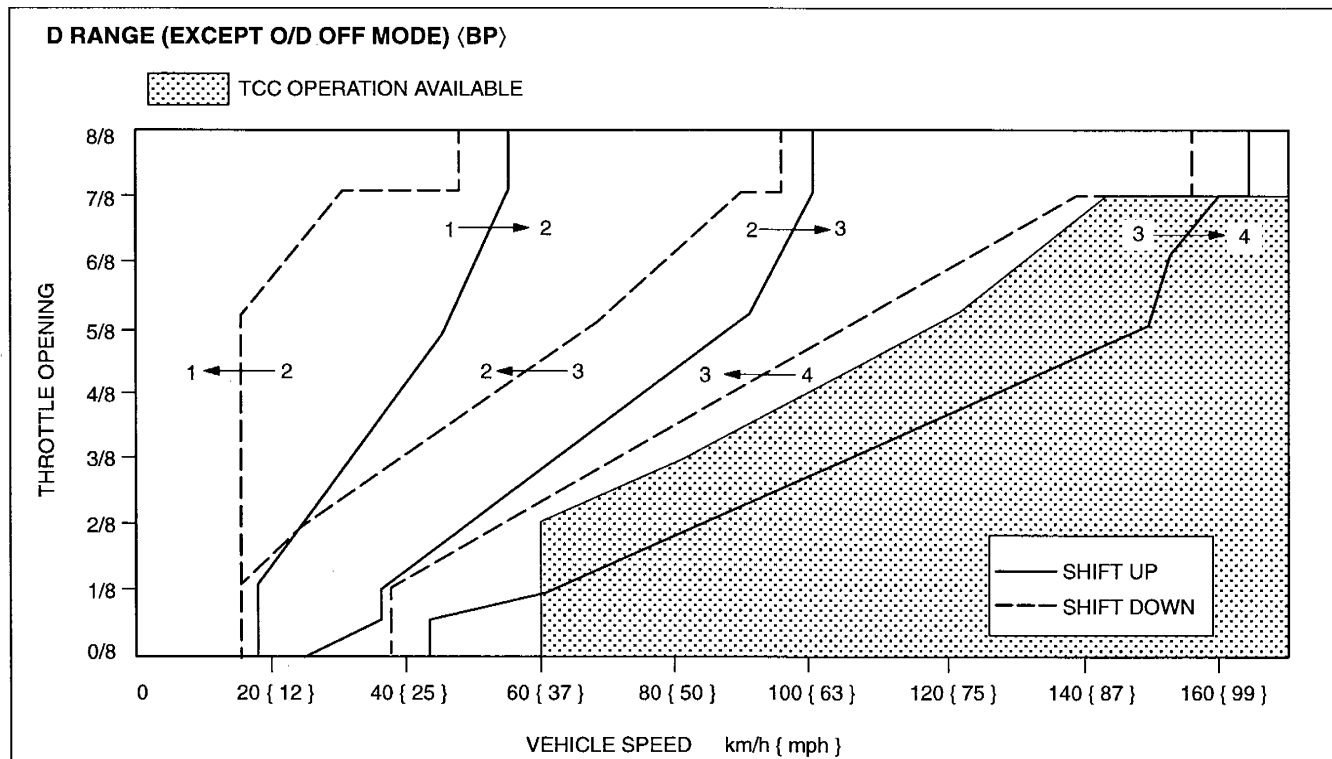
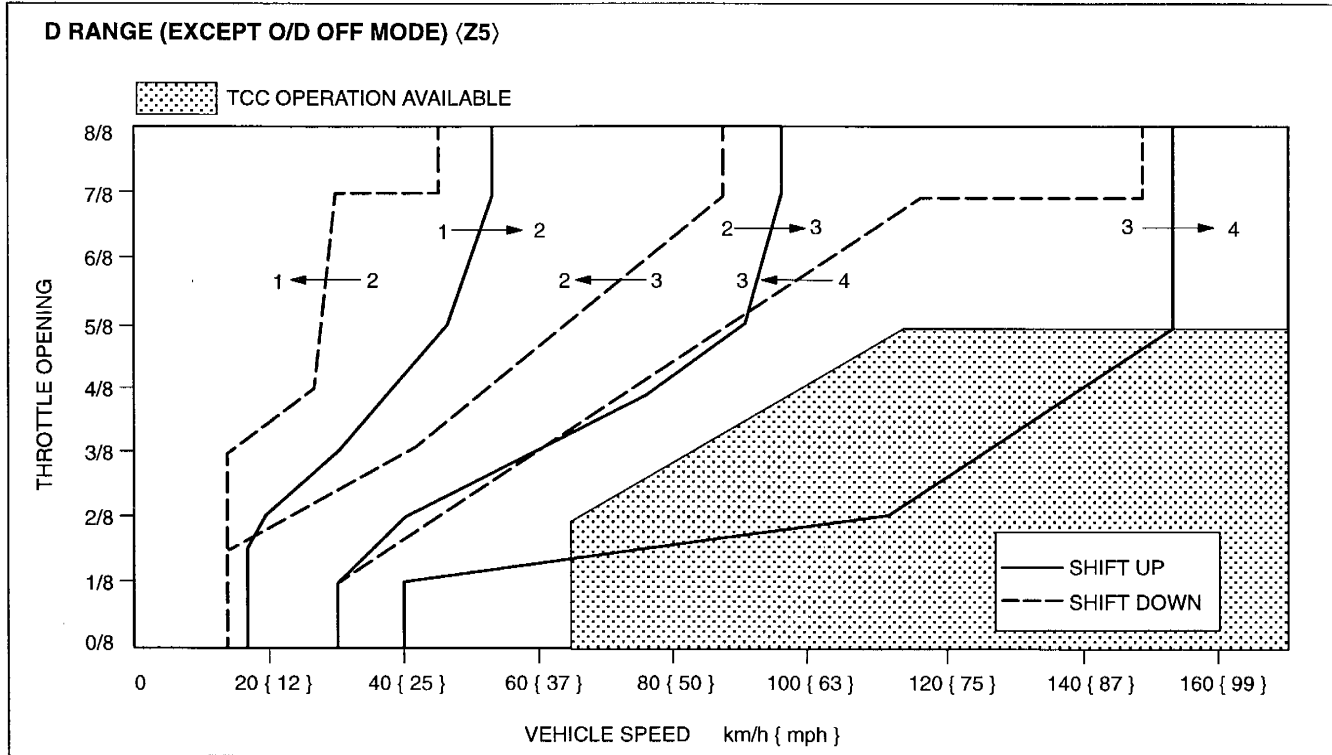

D RANGE TEST

D range (Except O/D OFF mode)

1. Shift the selector lever to D range.
2. Accelerate the vehicle to half throttle and wide open throttle.
3. Verify that 1-2, 2-3, and 3-4 upshifts and downshifts are obtained. The shift points must be as shown in the table below.
4. Drive the vehicle in fourth, third, and second gears and verify that kickdown occurs for 4→3, 4→2, 3→2, 3→1, 2→1, and that the shift points are as shown in the table below.
5. Decelerate the vehicle and verify that engine braking effect is felt in fourth and third gears.

Note

- There is torque converter clutch non-operation in the following conditions.
 1. The engine coolant temperature is below 62 °C { 144 °F }.
 2. The closed throttle position switch is ON.
 3. The brake switch is ON.

6. Drive the vehicle and verify that torque converter clutch operation is obtained.

D range (O/D OFF mode)

1. Turn the O/D OFF switch from OFF to ON.
2. Accelerate the vehicle to half throttle and wide open throttle, and verify that 1-2 and 2-3 upshift and downshift are obtained. The shift points must be as shown in the table below.
3. Drive the vehicle in third and second gears and verify that kickdown occurs for 3→2, 3→1, 2→1, and that the shift points are as shown in the table below.
4. Decelerate the vehicle and verify that engine braking effect is felt in third gear.



Shift Point

Range/Mode	Throttle condition	Shift	Vehicle speed (km/h { mph })		Turbine speed (rpm)		
			Z5	BP	Z5	BP	
D	Wide open throttle	1GR→2GR	52—58 { 32—36 }	53—59 { 33—36 }	5,600—6,200	5,300—5,850	
		2GR→3GR	94—102 { 58—63 }	98—106 { 61—65 }	5,600—6,000	5,400—5,800	
		3GR→4GR	149—159 { 92—99 }	162—172 { 101—106 }	5,750—6,100	5,800—6,100	
	Half throttle	1GR→2GR	33—43 { 20—27 }	33—42 { 21—26 }	3,600—4,600	3,300—4,150	
		2GR→3GR	64—84 { 40—52 }	66—85 { 41—52 }	3,800—4,950	3,650—4,650	
		3GR→4GR	127—152 { 79—94 }	112—142 { 70—88 }	4,900—5,800	4,000—5,050	
		TCC ON (4GR)	127—152 { 79—94 }	92—120 { 57—74 }	4,900—5,800	2,300—2,950	
	Closed throttle position	4GR→3GR	27—33 { 17—20 }	33—39 { 21—24 }	750—850	850—950	
		3GR→1GR	11—17 { 7—11 }	12—18 { 8—11 }	450—650	450—600	
	Kickdown (wide open throttle)	4GR→3GR	143—153 { 87—95 }	151—161 { 94—99 }	3,850—4,100	3,800—4,000	
		3GR→2GR	84—94 { 52—57 }	91—99 { 56—61 }	3,250—3,600	3,250—3,500	
		2GR→1GR	42—48 { 27—29 }	44—50 { 27—31 }	2,500—2,800	2,450—2,700	
	O/D OFF mode	Wide open throttle	1GR→2GR	52—58 { 32—36 }	53—59 { 33—36 }	5,600—6,200	5,300—5,850
			2GR→3GR	94—102 { 58—63 }	98—106 { 61—65 }	5,600—6,000	5,400—5,800
		Half throttle	1GR→2GR	33—42 { 20—27 }	32—41 { 20—25 }	3,600—4,600	3,200—4,050
2GR→3GR			64—84 { 40—52 }	66—85 { 41—52 }	3,800—4,950	3,650—4,650	
Closed throttle position		4GR→3GR	149—155 { 92—96 }	162—168 { 100—104 }	4,050—4,150	4,050—4,150	
		3GR→1GR	11—17 { 7—11 }	12—18 { 8—11 }	450—650	450—600	
Kickdown (wide open throttle)		3GR→2GR	84—92 { 52—57 }	91—99 { 57—61 }	3,250—3,600	3,250—3,500	
		2GR→1GR	42—48 { 27—29 }	44—50 { 27—31 }	2,500—2,800	2,450—2,700	

2 RANGE TEST**2 range**

1. Shift the selector lever to 2 range.
2. Accelerate the vehicle to half throttle and wide open throttle, and verify that second gear is held.
3. Decelerate the vehicle and verify that engine braking effect is felt.

Shift Point

Range	Throttle condition	Shift	Vehicle speed (km/h { mph })		Turbine speed (rpm)	
			Z5	BP	Z5	BP
2	—	4GR→3GR	149—155 { 92—96 }	162—168 { 100—104 }	4,050—4,150	4,050—4,150
		3GR→2GR	93—99 { 58—61 }	97—103 { 60—63 }	3,600—3,800	3,450—3,650

1 RANGE TEST**1 range**

1. Shift the selector lever to 1 range.
2. Accelerate the vehicle with half throttle and wide open throttle, and verify that first gear is held.
3. Decelerate the vehicle and verify that engine braking effect is felt.

Shift Point

Range	Throttle condition	Shift	Vehicle speed (km/h { mph })		Turbine speed (rpm)	
			Z5	BP	Z5	BP
1	—	2GR→1GR	42—48 { 26—29 }	44—50 { 27—31 }	2,500—2,800	2,450—2,700

P POSITION TEST

Shift into P position on a gentle slope, release the brake, and verify that the vehicle does not roll.

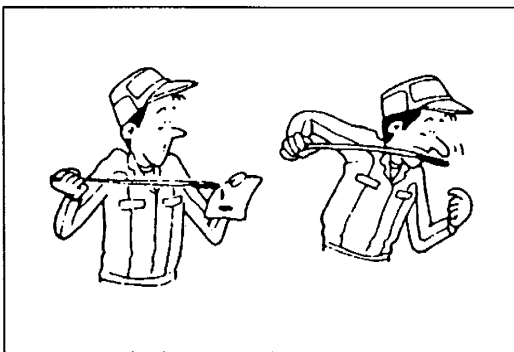
**AUTOMATIC TRANSAXLE FLUID (ATF)****ATF****Inspection****Condition**

One way of determining whether the transaxle should be disassembled is by noting:

1. If the ATF is muddy or varnished.
2. If the ATF smells strange.

ATF condition

Color	Condition
Clear red	Normal
Dark	Powertrain components damaged
Light pink	Water in the ATF
Reddish-brown	Deterioration of the ATF

3. If ATF condition is not OK, repair as follows
 - Dark color condition
Overhaul transaxle and repair or replace parts as necessary.
 - Light pink and/or reddish-brown condition.
Replace ATF.

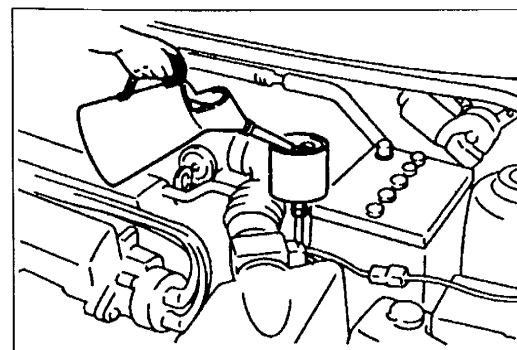
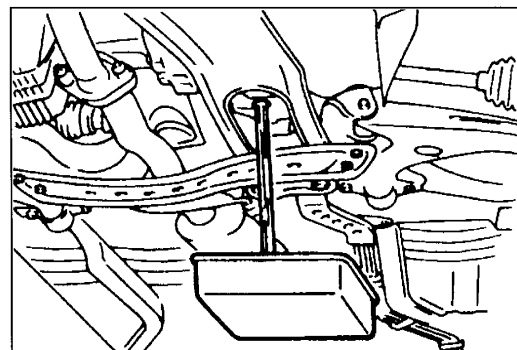
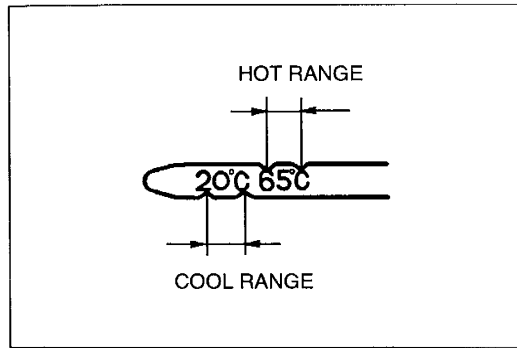
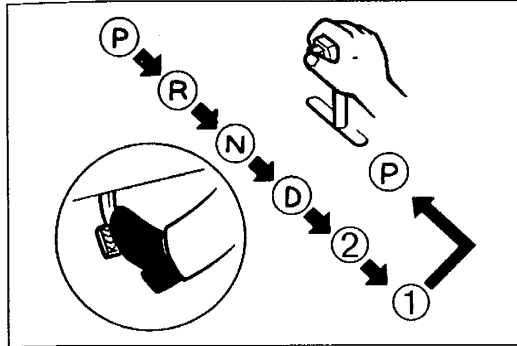
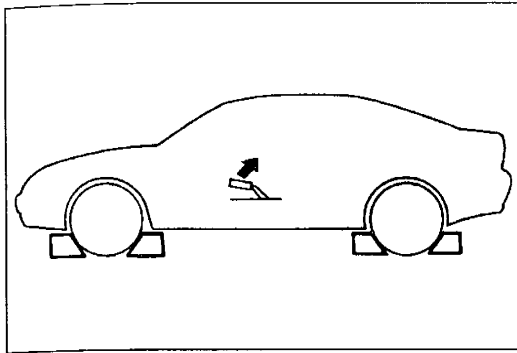

Level

1. Park the vehicle on level ground.
2. Apply the parking brake and position wheel chocks securely to prevent the vehicle from rolling.
3. If necessary, inspect the ATF before warming up the engine. In this case, use the cool range (15—25 °C { 59—77 °F }).
4. Warm up the engine until the ATF reaches 60—70 °C { 140—158 °F }.
5. While depressing the brake pedal, shift the selector lever to each range (P—1), pausing momentarily in each range.
6. Shift back to P position.
7. While the engine is idling, ensure that the dipstick is in the HOT 65 °C { 149 °F } range. Add ATF to the specification if necessary.

ATF type: M-III or Dexron®II

Replacement

1. Remove the dipstick.
2. Remove the drain plug and washer.
3. Drain the ATF into a suitable container.
4. Install a new washer and the drain plug.

Tightening torque:

40—53 N·m { 4.0—5.5 kgf·m , 29—39 ft·lbf }

5. Remove the dipstick and add the specified amount and type of ATF through the oil filler tube.



ATF type: M-III or Dexron®II

Capacity: 4.9 L { 5.2 US qt , 4.3 Imp qt }

6. Install the dipstick.
7. Ensure that the dipstick is in the HOT 65 °C { 149 °F } range.
8. Add ATF to the specified level if necessary.

THROTTLE CABLE

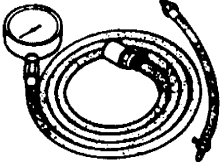
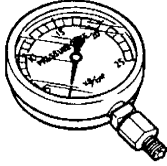
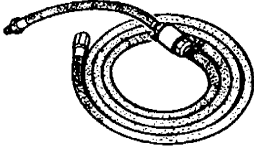
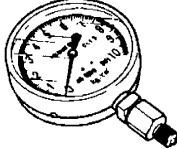
PREPARATION SST

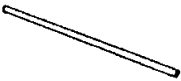
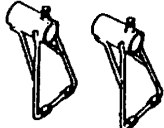
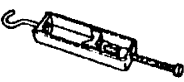
<p>49 0378 400B Oil pressure gauge set</p> 	<p>For adjustment of throttle cable</p>	<p>49 B019 902 Oil pressure gauge (Part of 49 0378 400B)</p> 	<p>For adjustment of throttle cable</p>
<p>49 B019 903 Hose (Part of 49 0378 400B)</p> 	<p>For adjustment of throttle cable</p>	<p>49 B019 901 Oil pressure gauge</p> 	<p>For adjustment of throttle cable</p>
<p>49 H019 002 Adapter</p> 	<p>For adjustment of throttle cable</p>	<p>49 G017 5A0 Support, engine</p> 	<p>For support of engine</p>
<p>49 G017 501 Bar (Part of 49 G017 5A0)</p> 	<p>For support of engine</p>	<p>49 G017 502 Support (Part of 49 G017 5A0)</p> 	<p>For support of engine</p>
<p>49 G017 503 Hook (Part of 49 G017 5A0)</p> 	<p>For support of engine</p>	<p>—</p>	<p>—</p>

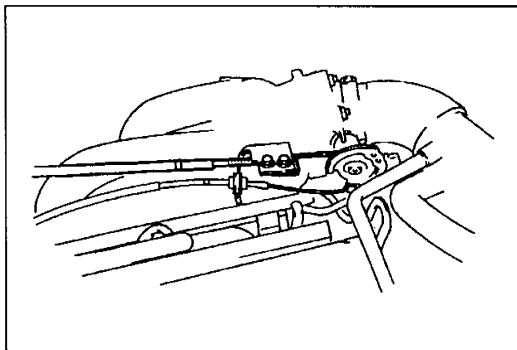

THROTTLE CABLE

Inspection

1. Check the cable and housing for damage.
2. Verify that the accelerator operates smoothly.
3. Replace the throttle cable assembly if necessary.

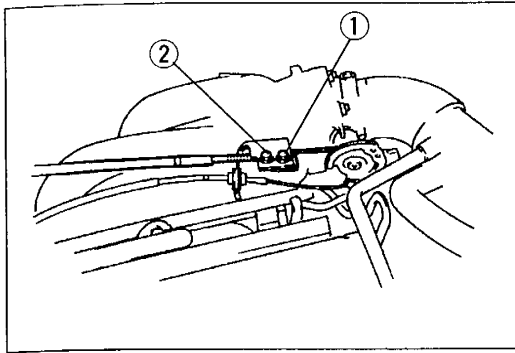

Replacement

1. Remove the throttle cable from the throttle lever (throttle body).

Note

- Loosen bolt ① first.

2. Loosen and remove bolts ① and ②.
3. Remove the throttle cable from the bracket.

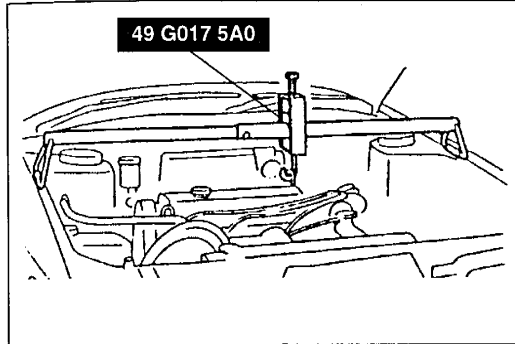

4. Remove the splash shield.
5. Drain the ATF into a container.
6. Suspend the engine by using the **SST**.
7. Remove the transverse member (BP).
8. Remove the engine mounting member.
9. Remove the oil pan and gasket.
10. Remove the control valve body. (Refer to page K-43.)

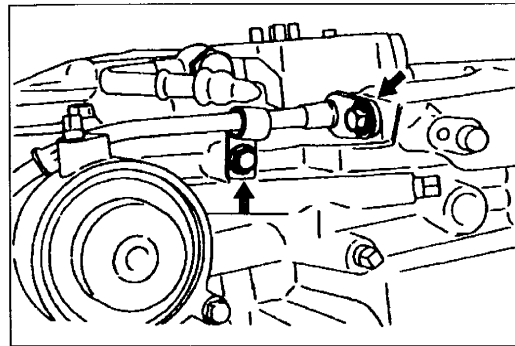

11. Remove the throttle cable from the throttle cam.
12. Remove the mounting bolts and throttle cable from the transaxle.

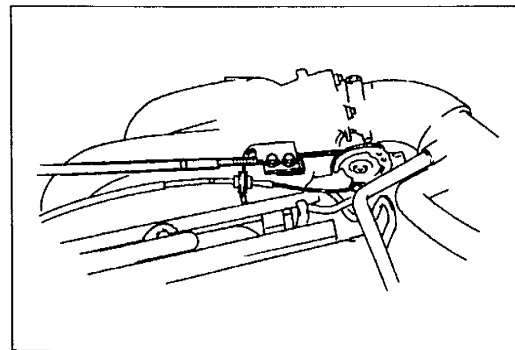

13. Install a new throttle cable to the throttle cam.
14. Connect the throttle cable to the throttle lever (throttle body).

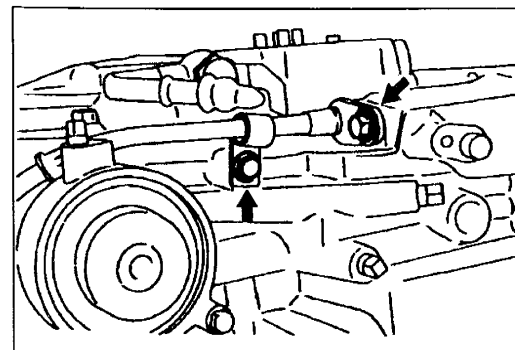

15. Install new bolts in the areas indicated in the figure and tighten them to the specified torque.

Tightening torque:

7.9—10.7 N·m { 80—110 kgf·cm , 70—95 in·lbf }

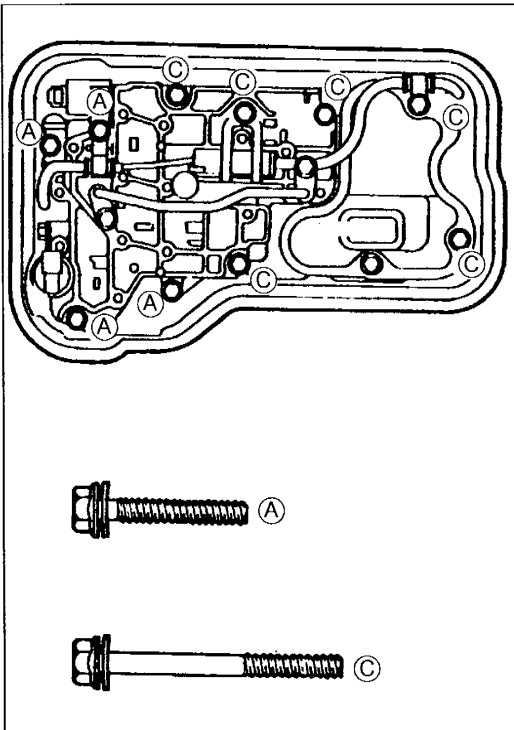

16. Install the control valve body.

Bolt length (measured from below the head)

- Ⓐ: 30 mm { 1.18 in }
- Ⓒ: 50 mm { 1.97 in }

Tightening torque:

7.9—10.7 N·m { 80—110 kgf·cm , 70—95 in·lbf }

Note

- Lightly apply sealant to both sides of the gasket.

17. Install a new gasket and install the oil pan.

Tightening torque:

8.4—10.7 N·m { 85—110 kgf·cm , 74—95 in·lbf }

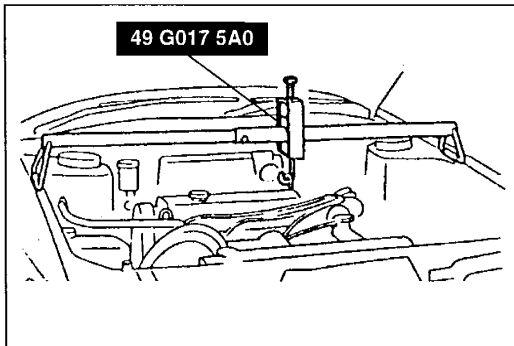

18. Install the engine mounting member.
(Refer to page K-43.)

19. Install the transverse member (BP).

20. Remove the **SST**.

21. Install the splash shield.

22. Add ATF, and with the engine idling, check the ATF level and check for leaks. (Refer to page K-10.)

23. Adjust the throttle cable as follows.

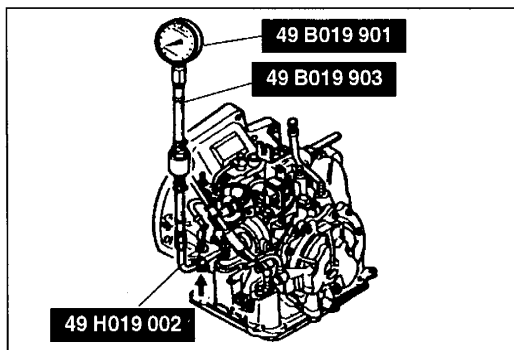

Adjustment

1. Remove the square-head plug L and install the **SSTs**.
2. Shift into P position and start the engine. Warm up the engine to normal operating temperature, and adjust the idle speed if necessary. (Refer to section F1, F2.)

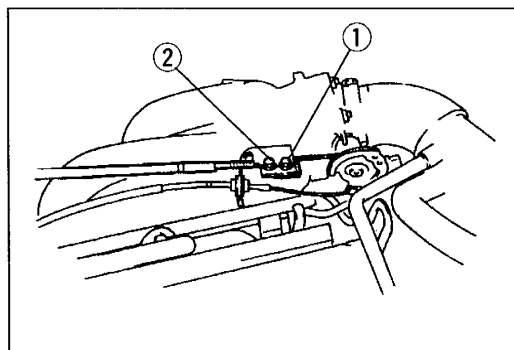

Caution

- Loosen bolt ① first.

3. Loosen bolts ① and ②.

4. Verify that the throttle lever is closed throttle position.

5. Tighten bolt ①.

Tightening torque:

6.9—9.8 N·m { 70—100 kgf·cm , 61—86 in·lbf }

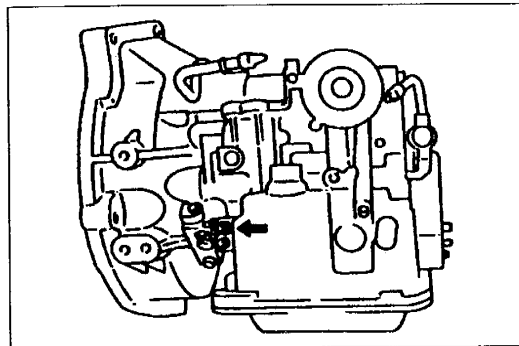
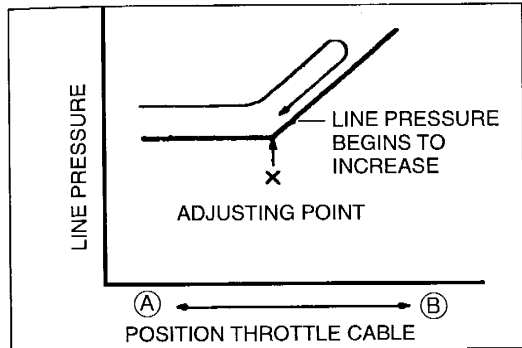
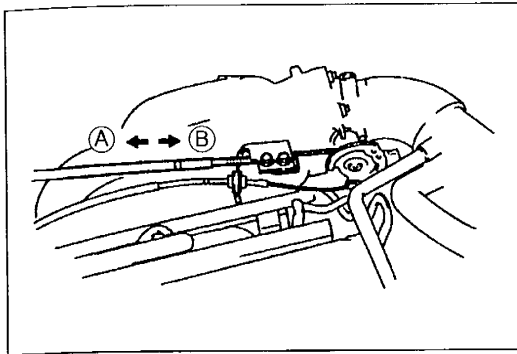

- Pull the throttle cable in the direction of arrow (A) as shown in the figure until the line pressure exceeds the specified pressure.

Caution

- If the line pressure will not decrease to the adjustment pressure, tighten bolt (2) with the line pressure at the closest point (point X) to the adjustment pressure.

- Push the throttle cable in the direction of arrow (B) until the line pressure decreases to the adjustment pressure.

Adjustment pressure:

490 kPa { 5.0 kgf/cm² , 71 psi } (Engine is idling)

- Tighten bolt (2).

Tightening torque:

6.9—9.8 N·m { 70—100 kgf·cm , 61—86 in·lbf }

- Stop the engine and verify that the throttle cable moves smoothly.
- Restart the engine and accelerate it slightly, then run it at idle.
- Verify that the line pressure is within specification.

Specified pressure:

422—558 kPa { 4.3—5.7 kgf/cm² , 62—81 psi }
(Engine is idling)





- If not correct, repeat from step 3.
- Stop the engine.
- Remove the SSTs and install a new square-head plug L.

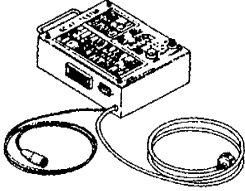

Tightening torque:

5.0—9.8 N·m { 50—100 kgf·cm , 44—86 in·lbf }

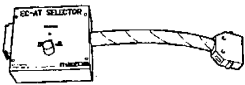
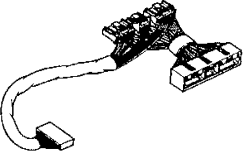
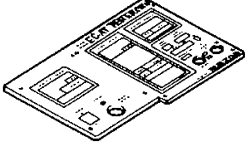
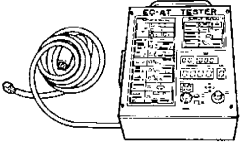
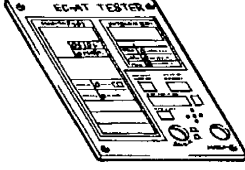
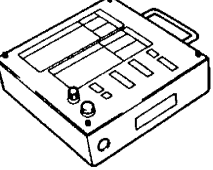
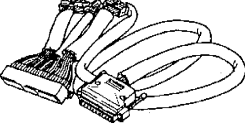
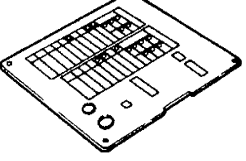
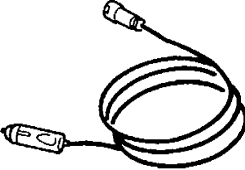
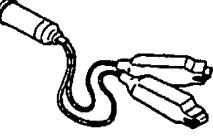
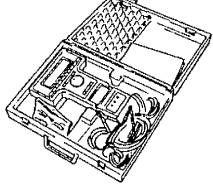
ELECTRICAL SIGNAL INSPECTION

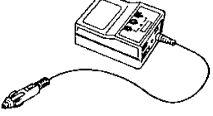
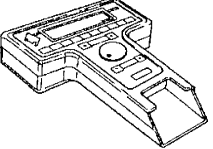
PREPARATION SST

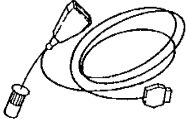
<p>49 G019 901 EC-AT Tester</p> 	<p>For inspection of electrical signal</p>	<p>49 H019 902 Adapter</p> 	<p>For inspection of electrical signal</p>
<p>49 B019 9A1 Adapter</p> 	<p>For inspection of electrical signal</p>	<p>49 B019 915 Harness Adapter</p> 	<p>For inspection of electrical signal</p>
<p>49 B019 905 Panel</p> 	<p>For inspection of electrical signal</p>	<p>49 G019 901B EC-AT Tester</p> 	<p>For inspection of electrical signal</p>
<p>49 B019 904 Panel</p> 	<p>For inspection of electrical signal</p>	<p>49 G019 901C EC-AT Tester</p> 	<p>For inspection of electrical signal</p>
<p>49 B019 913A Harness Adapter</p> 	<p>For inspection of electrical signal</p>	<p>49 E019 903 Panel</p> 	<p>For inspection of electrical signal</p>
<p>49 G019 929 Power Harness</p> 	<p>For inspection of electrical signal</p>	<p>49 D088 008 Harness Adapter Power</p> 	<p>For inspection of electrical signal</p>
<p>49 T088 0A0 NGS set</p> 	<p>For inspection of electrical signal</p>	<p>49 T088 010B Program Card</p> 	<p>For inspection of electrical signal</p>
<p>49 T088 002 Vehicle Interface Module (Part of 49 T088 0A0)</p> 	<p>For inspection of electrical signal</p>	<p>49 T088 001 Control Unit (Part of 49 T088 0A0)</p> 	<p>For inspection of electrical signal</p>

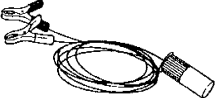
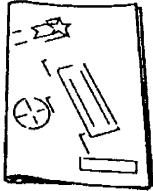
<p>49 T088 004</p> <p>NGS OBDII Adapter (Part of 49 T088 0A0)</p>	 <p>For inspection of electrical signal</p>	<p>49 T088 009</p> <p>Case (Part of 49 T088 0A0)</p>	 <p>For inspection of electrical signal</p>
<p>49 T088 006</p> <p>Battery Hookup Adapter (Part of 49 T088 0A0)</p>	 <p>For inspection of electrical signal</p>	<p>49 T088 008</p> <p>Instruction Manual</p>	 <p>For inspection of electrical signal</p>

ELECTRICAL SIGNAL INSPECTION

Assembly of SST

EC-AT tester (49 G019 901), adapter (49 H019 902), and adapter (49 B019 9A1)

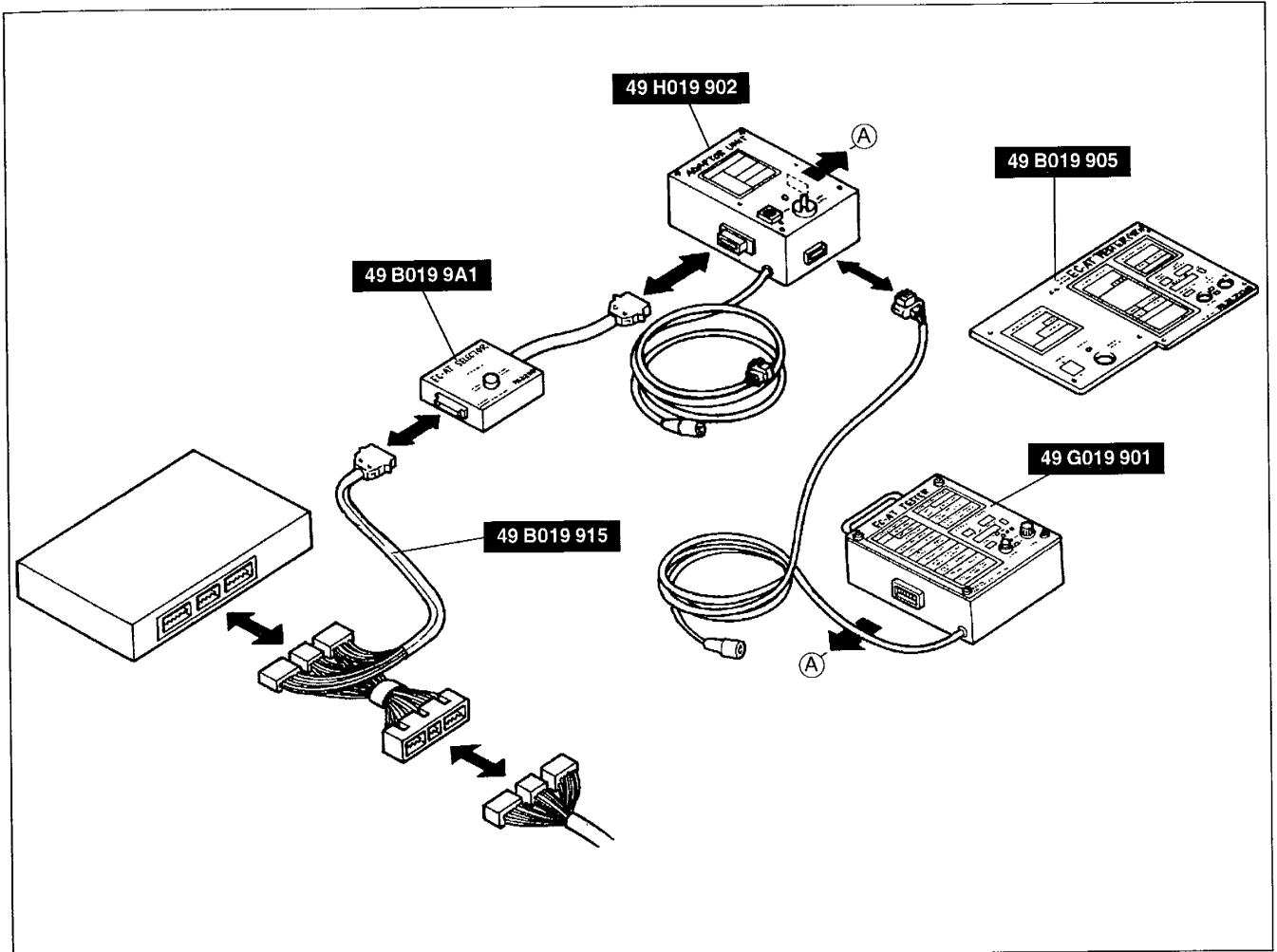

EC-AT tester (49 G019 901B) and adapter (49 B019 9A1)

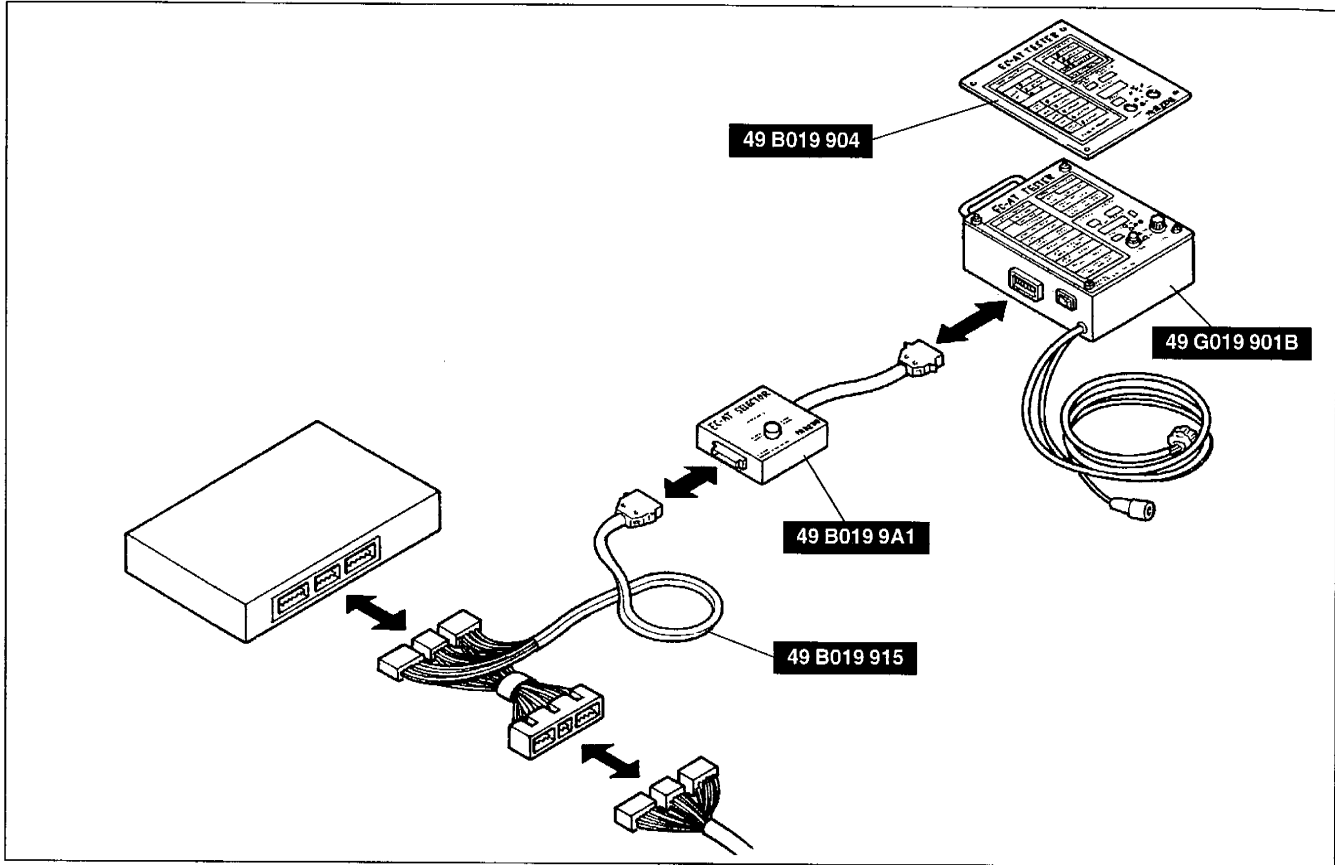

EC-AT tester (49 G019 901C)

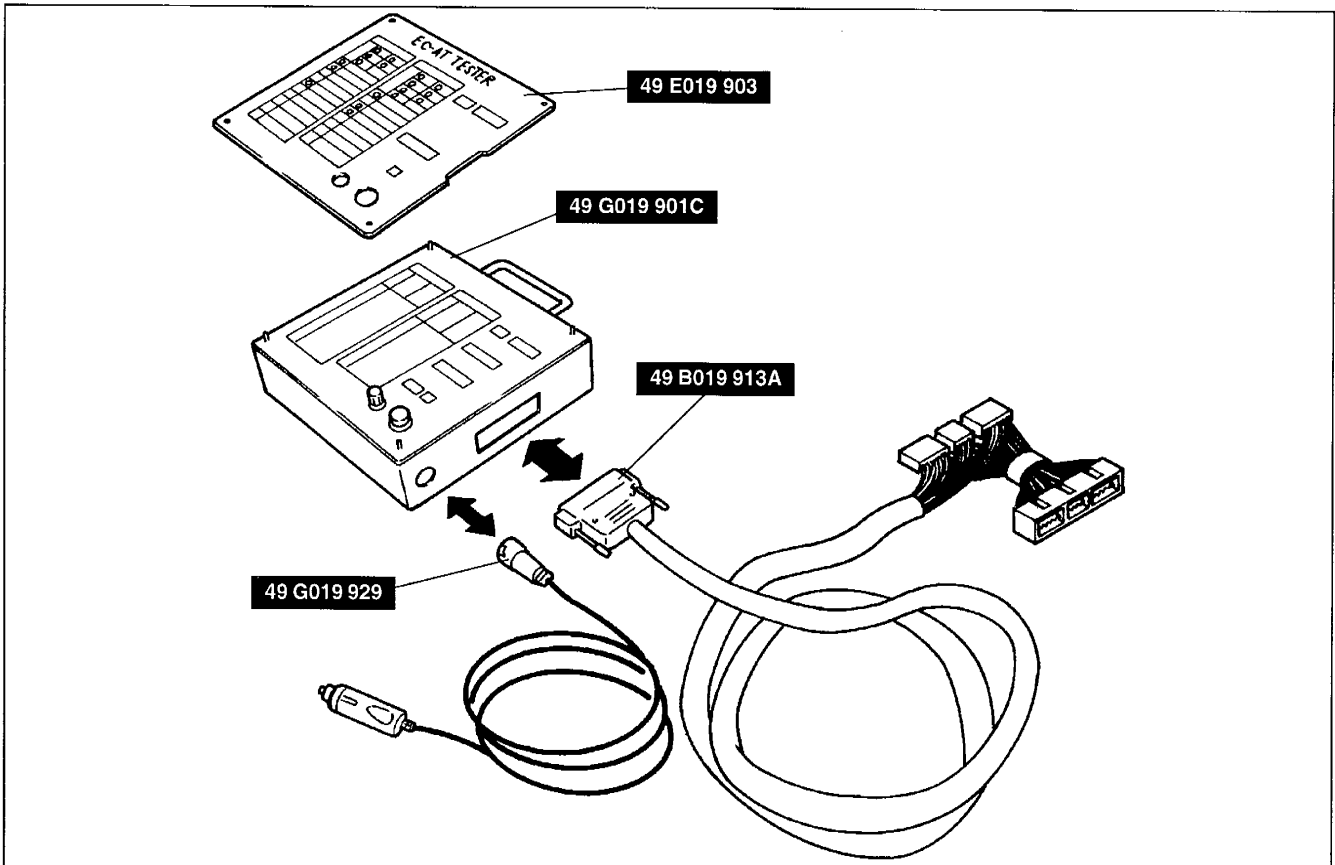

NGS

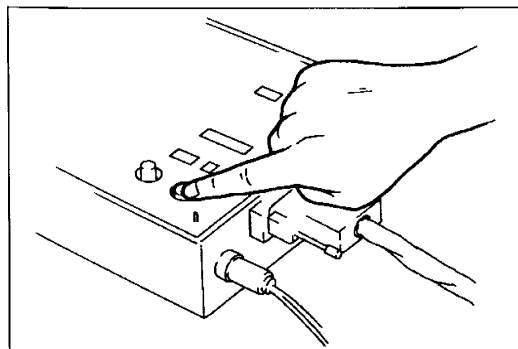
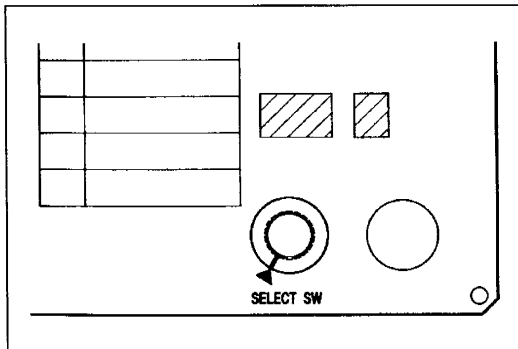
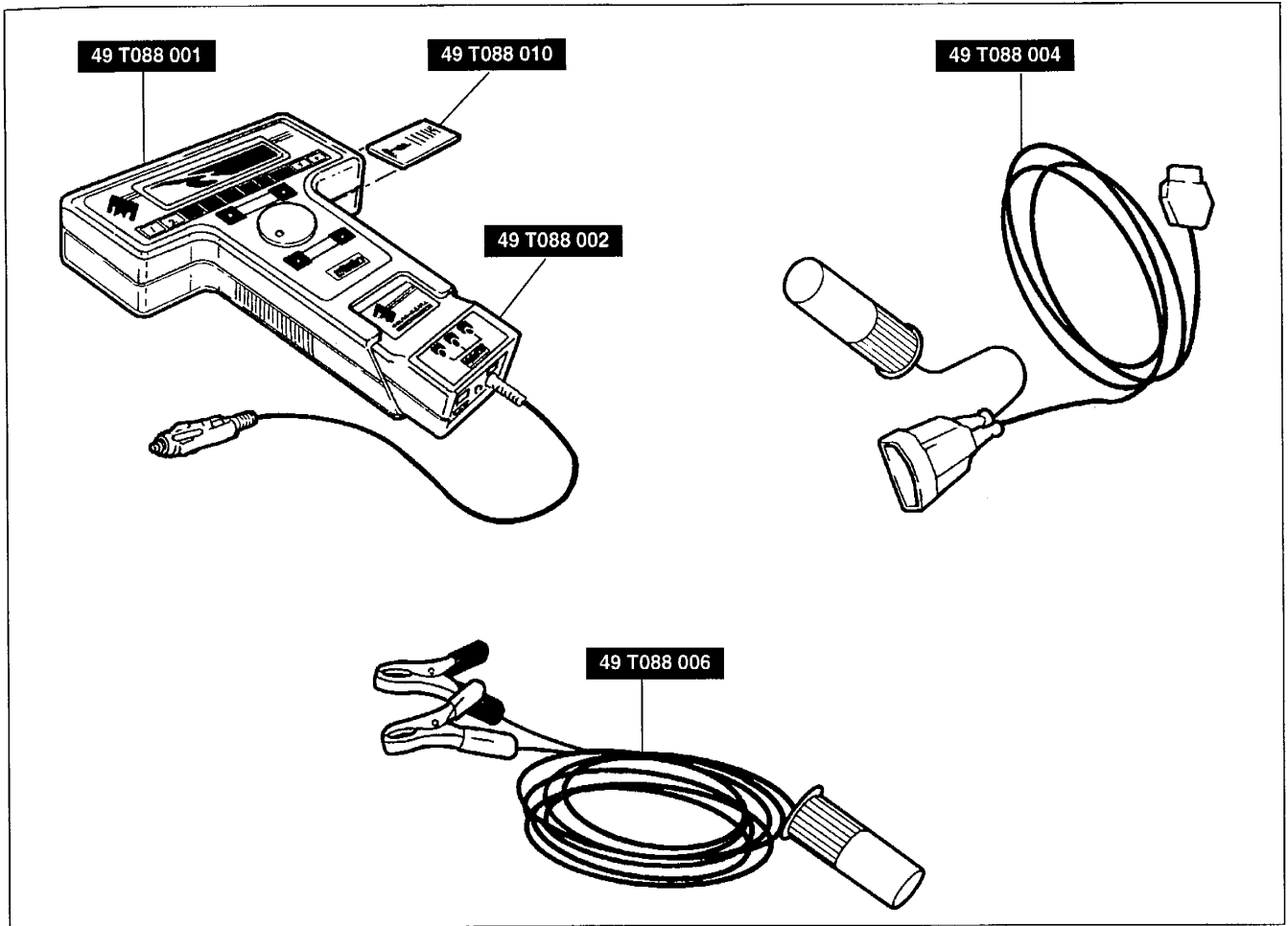

Inspection Procedure

Caution

- Do not connect the NGS to the data link connector 2 when the EC-AT tester is connected to the powertrain control module. Doing so can cause incorrect test results.

When using the EC-AT tester (49 G019 901C)

1. Assemble the SST. (Refer to page K-18.)
2. Turn the EC-AT tester select switch to the ▲ mark on the panel.
3. Turn the ignition switch and the EC-AT tester main switch to ON.
4. Check the indication of the respective light or digital display in each condition, referring to the indication table on the following page.

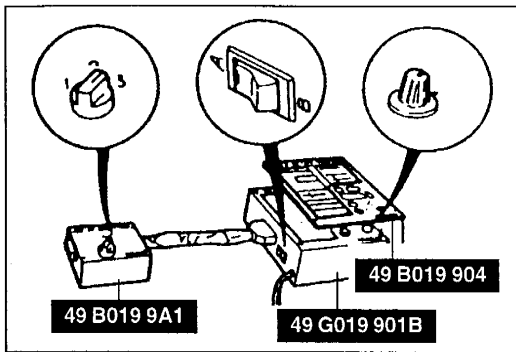

When using the EC-AT tester (49 G019 901B)

1. Assemble the **SST**. (Refer to page K-18.)
2. Set the EC-AT selector switch to position 3.
3. Set the EC-AT tester vehicle switch to the 323 position.
4. Set the EC-AT tester select switch to position A.
5. Turn the ignition switch and the EC-AT tester main switch to ON.
6. Check the indication of the respective light or digital display in each condition, referring to the indication table on the following page.

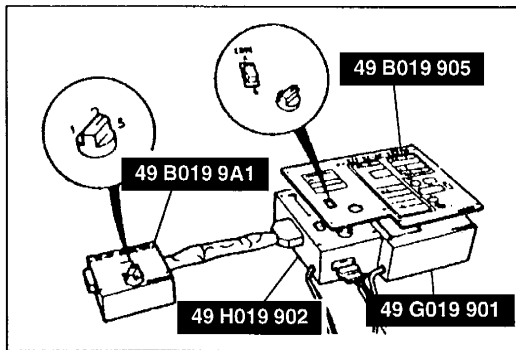

When using the EC-AT tester (49 G019 901) and adapter unit (49 H019 902)

1. Assemble the **SST**. (Refer to page K-17.)
2. Set the EC-AT selector switch to position 3.
3. Set the adapter unit vehicle switch to the 323 position.
4. Set the adapter unit select switch to position A.
5. Turn the ignition switch and the EC-AT tester main switch to ON.
6. Check the indication of the respective light or digital display in each condition, referring to the indication table on the following page.

When using the NGS

1. Assemble the **SST** (NGS). (Refer to page K-19.)
2. Select the PID DATA MONITOR AND RECORD function. (Refer to section F1, F2.)

**Indication Table Of Light And Digital Display
EC-AT tester (49 G019 901)**

Item		Indication	Condition	Possible cause
Input (Light)				
Transaxle range switch (INHIBITOR SW)	P, N	ON	P or N position	Transaxle range switch or wiring
		OFF	R position, all ranges	
	D	ON	D range	
		OFF	Other ranges, all positions	
	2 (S)	ON	2 range	
		OFF	Other ranges, all positions	
	1 (L)	ON	1 range	
		OFF	Other ranges, all positions	
Engine coolant temperature switch (WATER THERMO SW)		Not used		
Transaxle fluid temperature sensor (ATF THERMOSENSOR)		ON	ATF temperature above 130 °C { 266 °F }	Transaxle fluid temperature sensor or wiring
		OF	ATF temperature below 130 °C { 266 °F }	
O/D OFF switch (HOLD SW)		ON	O/D OFF switch released	O/D OFF switch or wiring
		OFF	O/D OFF switch depressed	
Closed throttle position switch (IDLE SW)		ON	Closed throttle position	Closed throttle position switch or wiring
		OFF	Other position	
Brake switch (BRAKE LIGHT SW)		ON	Brake pedal depressed	Brake switch or wiring
		OFF	Brake pedal released	
Input (Digital Display)				
Throttle position sensor voltage (THROTTLE SENSOR V.)		PCM terminal voltage	Constant	Throttle position sensor or wiring
VEHICLE SPEED	km/h	Vehicle speed	Vehicle moving	Vehicle speed sensor, vehicle speedometer sensor, or wiring
DRUM SPEED	rpm	Drum speed	All the time	Input/turbine speed sensor or wiring
Output (Light)				
SOLENOID VALVE	Shift solenoid A (1-2)	ON	2GR, 3GR, or 4GR	Powertrain control module, shift solenoid A, or wiring
		OFF	1GR	
	Shift solenoid B (2-3)	ON	1GR or 2GR	Powertrain control module, shift solenoid B, or wiring
		OFF	3GR or 4GR	
	Shift solenoid C (3-4)	ON	1GR, 2GR, or 4GR	Powertrain control module, shift solenoid C, or wiring
		OFF	3GR	
	TCC (LOCK-UP)	ON	TCC operation	Powertrain control module, TCC solenoid valve, or wiring
		OFF	TCC non-operation	
SHIFT SIGNAL		Not used		
O/D OFF indicator light (HOLD INDICATOR)		Not used		
Output (Digital Display)				
GEAR	1	First gear	—	
	2	Second gear		
	3	Third gear		
	4	Fourth gear		

EC-AT tester (49 G019 901B)

Item		Indication	Condition	Possible cause
Input (Light)				
Transaxle range switch (INHIBITOR SW)	P, N	ON	P or N position	Transaxle range switch or wiring
		OFF	R position, all ranges	
	D	ON	D range	
		OFF	Other ranges, all positions	
	2 (S)	ON	2 range	
		OFF	Other ranges, all positions	
	1 (L)	ON	1 range	
		OFF	Other ranges, all positions	
Engine coolant temperature switch (WATER THERMO SW)		Not used		
Transaxle fluid temperature sensor (ATF THERMOSENSOR)		ON	ATF temperature above 130 °C { 266 °F }	Transaxle fluid temperature sensor or wiring
		OFF	ATF temperature below 130 °C { 266 °F }	
O/D OFF switch (HOLD SW)		ON	O/D OFF switch released	O/D OFF switch or wiring
		OFF	O/D OFF switch depressed	
Closed throttle position switch (IDLE SW)		ON	Closed throttle position	Closed throttle position switch or wiring
		OFF	Other position	
Brake switch (BRAKE LIGHT SW)		ON	Brake pedal depressed	Brake switch or wiring
		OFF	Brake pedal released	
Input (Digital Display)				
Throttle position sensor voltage (THROTTLE SENSOR V.)		PCM terminal voltage	Constant	Throttle position sensor or wiring
VEHICLE SPEED	km/h	Vehicle speed	Vehicle moving	Vehicle speed sensor, vehicle speedometer sensor, or wiring
DRUM SPEED	rpm	Drum speed	All the time	Input/turbine speed sensor or wiring
Output (Light)				
SOLENOID VALVE	Shift solenoid A (1-2)	ON	2GR, 3GR, or 4GR	Powertrain control module, shift solenoid A, or wiring
		OFF	1GR	
	Shift solenoid B (2-3)	ON	1GR or 2GR	Powertrain control module, shift solenoid B, or wiring
		OFF	3GR or 4GR	
	Shift solenoid C (3-4)	ON	1GR, 2GR, or 4GR	Powertrain control module, shift solenoid C, or wiring
		OFF	3GR	
	TCC (LOCK-UP)	ON	TCC operation	Powertrain control module, TCC solenoid valve, or wiring
		OFF	TCC non-operation	
SHIFT SIGNAL		Not used		
O/D OFF indicator light (HOLD INDICATOR)		Not used		
Output (Digital Display)				
GEAR	1	First gear		—
	2	Second gear		
	3	Third gear		
	4	Fourth gear		

EC-AT tester (49 G019 901C)

Item		Indication	Condition	Possible cause
Input (Light)				
TRANSMISSION RANGE SWITCH	P/N	ON	P or N position	Transaxle range switch or wiring
		OFF	R position, all ranges	
	D	ON	D range	
		OFF	Other ranges, all positions	
	2 (S)	ON	2 range	
		OFF	Other ranges, all positions	
	1 (L)	ON	1 range	
		OFF	Other ranges, all positions	
HOLD/O/D OFF SWITCH		ON	O/D OFF switch depressed	O/D OFF switch or wiring
		OFF	O/D OFF switch released	
BRAKE SWITCH		ON	Brake pedal depressed	Brake switch or wiring
		OFF	Brake pedal released	
CLOSED THROTTLE POSITION SWITCH		ON	Closed throttle position	Closed throttle position switch or wiring
		OFF	Other position	
4GR INHIBIT SIGNAL		ON	RESUME/ACCEL switch ON or vehicle speed 8 km/h { 5 mph } lower than preset speed (Driving vehicle cruise control operation)	Cruise control module, switch, or wiring
		OFF	RESUME/ACCEL switch OFF and vehicle speed kept at preset speed (driving vehicle, cruise control operation and not cruise control operation)	
Input (Digital Display)				
THROTTLE POSITION SENSOR (V)		PCM terminal voltage	Constant	Throttle position sensor or wiring
VEHICLE SPEED (km/h)		Vehicle speed	Vehicle moving	Vehicle speed sensor, vehicle speedometer sensor, or wiring
TURBINE SPEED (rpm)		Drum speed	All the time	Input/turbine speed sensor or wiring
Transaxle fluid temperature sensor (TFT SENSOR) (V)		PCM terminal voltage	ATF temperature 10 °C { 50 °F }: ATF temperature 40 °C { 104 °F }	Transaxle fluid temperature sensor or wiring
Output (Light)				
SOLENOID VALVE	Shift solenoid A (SHIFT A)	ON	2GR, 3GR, or 4GR	Powertrain control module, shift solenoid A, or wiring
		OFF	1GR	
	Shift solenoid B (SHIFT B)	ON	1GR or 2GR	Powertrain control module, shift solenoid B, or wiring
		OFF	3GR or 4GR	
	Shift solenoid C (SHIFT C)	ON	1GR, 2GR, or 4GR	Powertrain control module, shift solenoid C, or wiring
		OFF	3GR	
	Torque converter clutch (TCC CONTROL)	ON	TCC operation	Powertrain control module, TCC solenoid valve, or wiring
		OFF	TCC non-operation	
HOLD/O/D OFF INDICATOR LIGHT		ON	O/D OFF mode	Powertrain control module, O/D OFF indicator light, or wiring
		OFF	Except O/D OFF mode	
Output (Digital Display)				
GEAR POSITION		1	First gear	—
		2	Second gear	
		3	Third gear	
		4	Fourth gear	

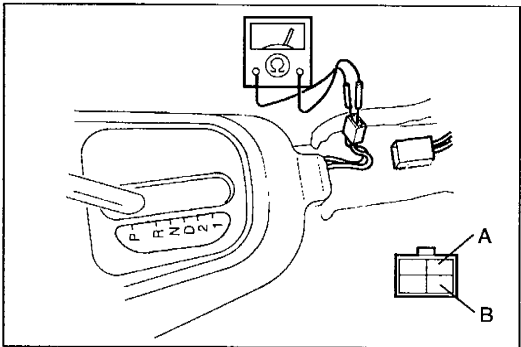
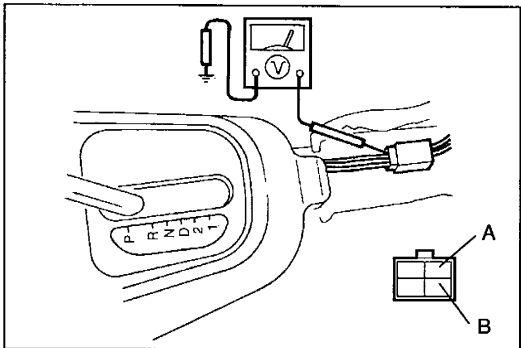
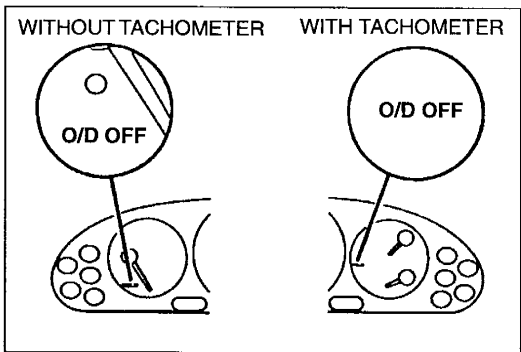

ELECTRICAL SYSTEM COMPONENTS

O/D OFF SWITCH

Inspection

Inspection of operation

1. Turn the ignition switch ON.
2. Verify that the O/D OFF indicator light is not illuminated. Depress the O/D OFF switch and verify that the O/D OFF indicator light illuminates.
3. If not as specified, check the terminal voltage of the O/D OFF switch.

Inspection of voltage

1. Remove the rear console and front console.
2. Turn the ignition switch to ON.
3. Measure the voltage at the O/D OFF switch connector terminals.

B+: Battery positive voltage

Position	Connector terminal	
	A	B
Normal (V)	B+	0
Depressed (V)	0	0

4. If not as specified, check for continuity at the O/D OFF switch.

Inspection of continuity

1. Disconnect the negative battery cable.
2. Disconnect the O/D OFF switch connector.
3. Check for continuity at the O/D OFF switch.

○—○: Continuity

Position	Connector terminal	
	A	B
Normal		
Depressed	○—○	○—○

4. If not as specified, replace the selector lever knob. (Refer to page K-52.)
5. If the switch is OK, check the wiring harness. (O/D OFF switch — Powertrain control module, O/D OFF switch — Body ground.)
6. Connect the O/D OFF switch connector.
7. Install the front console and rear console.
8. Connect the negative battery cable.

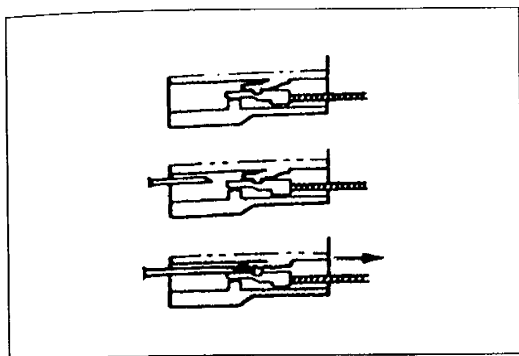

Replacement

1. Disconnect the negative battery cable.
2. Remove the rear console and front console.
3. Remove the indicator panel installation screws.
4. Disconnect the connector and remove the O/D OFF switch terminals.
5. Remove the selector lever knob.
6. Install a new selector lever knob.

Tightening torque:

2.0—2.9 N·m { 20—30 kgf·cm , 18—26 in·lbf }

7. Install the O/D OFF switch terminals and connect the connector.
8. Install the indicator panel installation screws.
(Refer to page K-52.)
9. Install the front console and rear console.
10. Connect the negative battery cable.

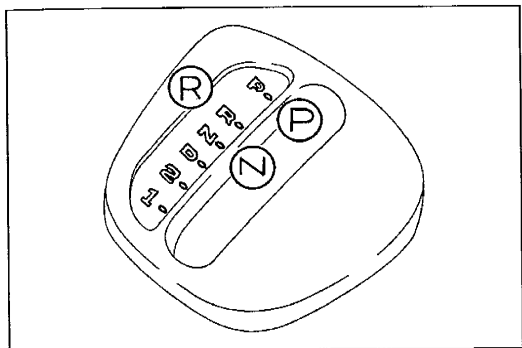

TRANSAXLE RANGE SWITCH

Inspection

Inspection of operation

1. Verify that the starter operates only with the ignition switch at the START position and the selector lever in P and N positions.
2. Verify that the back-up lights illuminate when shifted to R position with the ignition switch in ON position.
3. Verify that the position of the selector lever and the selector indicator light of the instrument cluster are aligned.
4. Check the transaxle range switch, if not as specified.

Inspection of continuity

1. Disconnect the negative battery cable.
2. Remove the battery, air cleaner assembly, and battery carrier.
3. Disconnect the transaxle range switch connector.
4. Check for continuity at the transaxle range switch.

○—○: Continuity

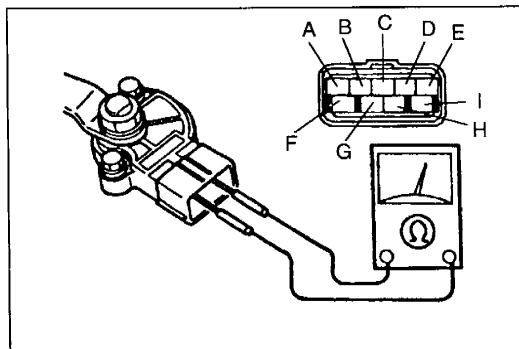

Position Range	Connector terminal								
	A	B	C	D	E	F	G	H	I
P	○				○				
R	○			○					
N	○							○	
D	○	○							
2	○							○	
1	○		○						

5. If not as specified, replace or adjust the transaxle range switch.
6. Connect the transaxle range switch connector.
7. Install the battery carrier, air cleaner assembly, and battery.
8. Connect the negative battery cable.

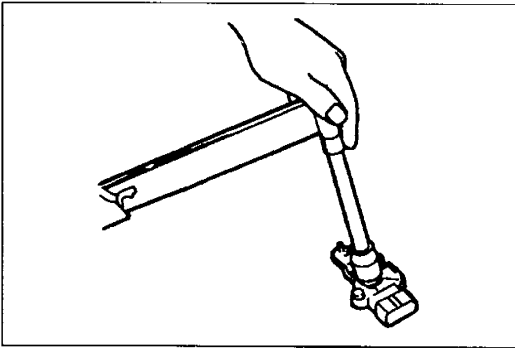
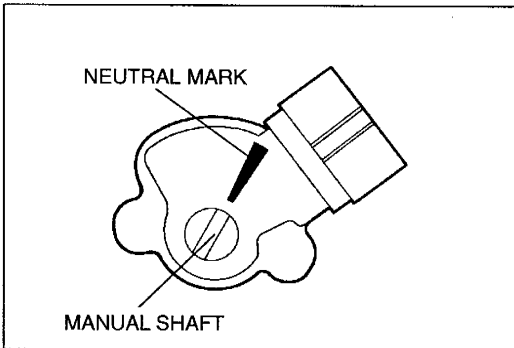
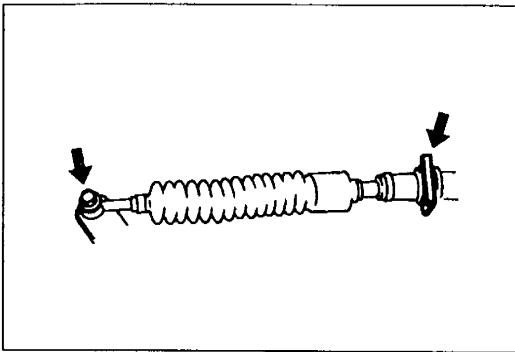

Replacement

1. Disconnect the negative battery cable.
2. Remove the battery, air cleaner assembly, and battery carrier.
3. Disconnect the transaxle range switch connector.
4. Remove the nut and clip, and disconnect the selector cable.
5. Remove the manual shaft nut.
6. Remove the lever.
7. Remove the transaxle range switch.
8. Rotate the manual shaft to the N position.
9. Turn the transaxle range switch so that the neutral mark is in line with the flat, straight surfaces on either side of the manual shaft.
10. Hand-tighten the transaxle range switch bolts.
11. Verify that there is continuity between terminals A and H of the transaxle range switch connector.
12. Tighten the transaxle range switch mounting bolts.

Tightening torque:

7.9—10.7 N·m { 80—110 kgf·cm , 70—95 in·lbf }

13. Install the lever.
14. Tighten the manual shaft nut by using a torque wrench.

Tightening torque:

32—46 N·m { 3.2—4.7 kgf·m , 24—33 ft·lbf }

15. Verify that selector lever range position and transaxle range switch are aligned; then connect the selector cable and install a new clip.
16. Check for continuity at the transaxle range switch. (Refer to page K-25.)
17. Connect the transaxle range switch connector.
18. Install the battery carrier, air cleaner assembly, and battery.
19. Connect the negative battery cable.
20. Check operation of the transaxle range switch. (Refer to page K-25.)

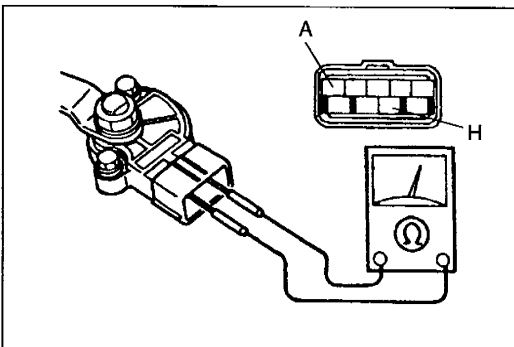

Adjustment

1. Disconnect the negative battery cable.
2. Remove the battery, air cleaner assembly, and battery carrier.
3. Remove the nut and clip, and disconnect the selector cable.
4. Rotate the manual shaft to the N position.
5. Disconnect the transaxle range switch connector.
6. Loosely tighten the transaxle range switch mounting bolts.
7. Connect an ohmmeter between terminals A and H.
8. Adjust the switch to the point where there is continuity between the terminals.

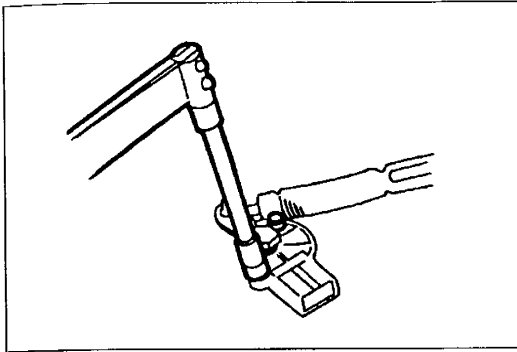

9. Tighten the transaxle range switch mounting bolts.

Tightening torque:

7.9—10.7 N·m { 80—110 kgf·cm , 70—95 in·lbf }

10. Verify that the selector lever range position and transaxle range switch are aligned.
11. Connect the transaxle range switch connector.
12. Connect the selector cable and install the nut and a new clip.
13. Install the battery carrier, air cleaner assembly, and battery.

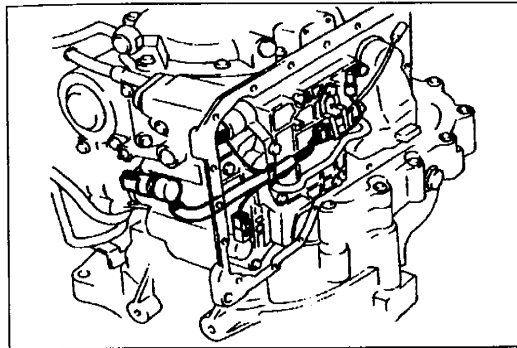

TRANSAXLE FLUID TEMPERATURE SENSOR

Inspection

1. Remove the control valve body. (Refer to page K-43.)

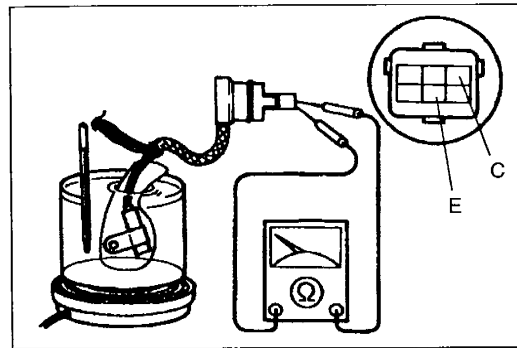

2. Place the transaxle fluid temperature sensor in ATF along with a thermometer as shown, and heat the ATF gradually.
3. Measure the resistance between terminals C and E of the transaxle fluid temperature sensor.

ATF temperature °C { °F }	Resistance (kΩ)
20 { 68 }	21.0—25.0
40 { 104 }	10.0—12.1
60 { 140 }	5.4—6.3
80 { 176 }	3.0—3.4
100 { 212 }	1.7—2.0
120 { 248 }	1.1—1.2
130 { 266 }	0.86—0.92

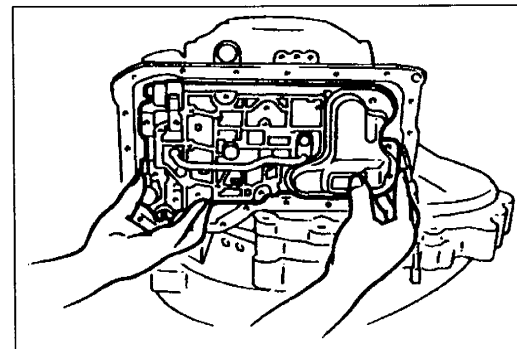

4. If not correct, replace the transaxle fluid temperature sensor.
5. Install the control valve body. (Refer to page K-43.)

TRANSAXLE FLUID TEMPERATURE SENSOR

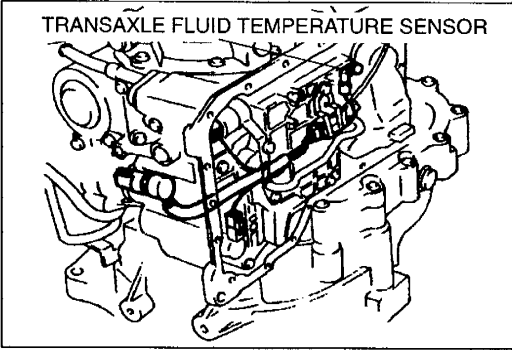
**Replacement**

1. Remove the control valve body.
(Refer to page K-43.)

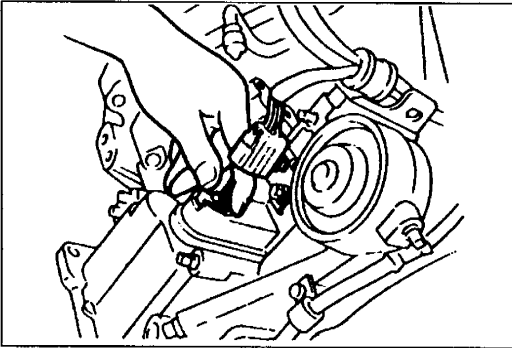

2. Apply ATF to a new O-ring and install it on a new solenoid valve connector.
3. Install the solenoid connector into the transaxle case.

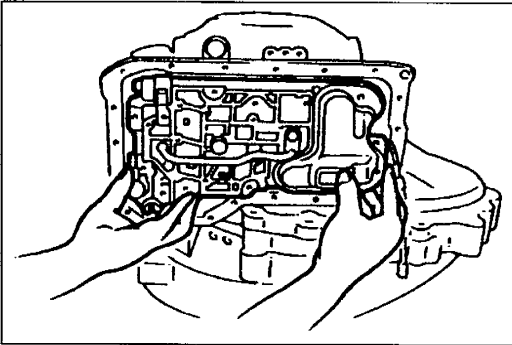

4. Install the control valve body. (Refer to page K-43.)
5. Connect the negative battery cable.
6. Carry out the time lag test and line pressure test.
(Refer to page K-2.)
7. Carry out the road test. (Refer to page K-8.)

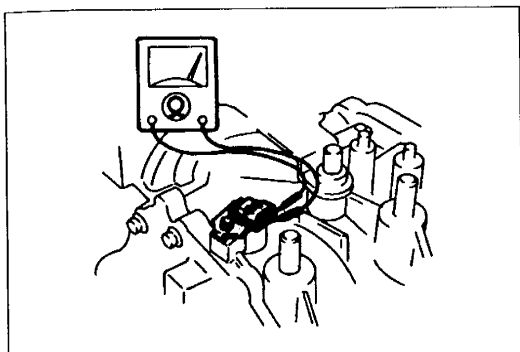
**INPUT/TURBINE SPEED SENSOR****Inspection****Inspection of resistance**

1. Disconnect the negative battery cable.
2. Remove the battery, air cleaner assembly, and battery carrier.
3. Disconnect the input/turbine speed sensor connector.
4. Measure the resistance between the terminals of the input/turbine speed sensor.

Resistance: 200—400 Ω

(ATF temperature: -40—160 °C { -40—320 °F })

5. If not correct, replace the input/turbine speed sensor.
6. Connect the input/turbine speed sensor connector.
7. Install the battery carrier, air cleaner assembly, and battery.
8. Connect the negative battery cable.

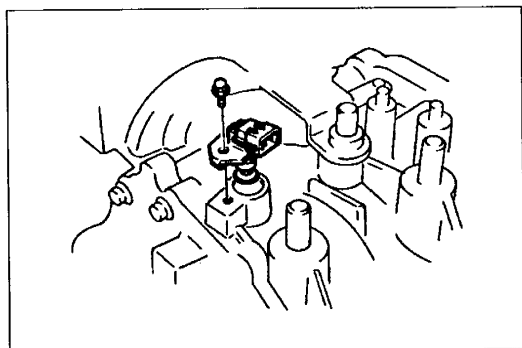
**Replacement**

1. Disconnect the negative battery cable.
2. Remove the battery, air cleaner assembly, and battery carrier.
3. Disconnect the input/turbine speed sensor connector.
4. Remove the input/turbine speed sensor.
5. Apply ATF to a new O-ring and install it on a new input/turbine speed sensor.
6. Install the input/turbine speed sensor.

Tightening torque:

7.9—10.7 N·m { 80—110 kgf·cm , 70—95 in·lbf }

7. Connect the input/turbine speed sensor connector.
8. Install the battery carrier, air cleaner assembly, and battery.
9. Connect the negative battery cable.

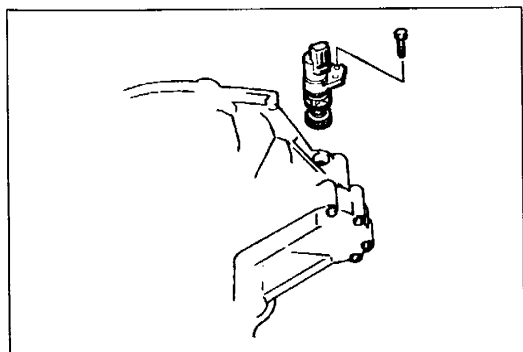
**VEHICLE SPEEDOMETER SENSOR****Inspection****Inspection of voltage**

1. Remove the vehicle speedometer sensor.

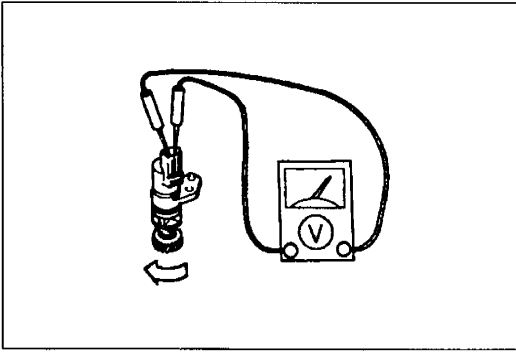

2. Measure the voltage between the terminals of the vehicle speedometer sensor while rotating the driven gear.

Meter needle	Action
Moves slightly under 5 V	Repair wiring harness (Instrument cluster — Vehicle speedometer sensor)
Does not move	Replace vehicle speedometer sensor

3. Install the vehicle speedometer sensor.

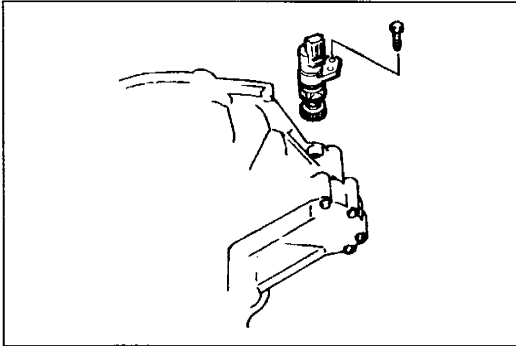

Replacement

1. Disconnect the negative battery cable.
2. Remove the battery, air cleaner assembly, and battery carrier.
3. Disconnect the vehicle speedometer sensor connector.
4. Remove the vehicle speedometer sensor.
5. Apply ATF to a new O-ring and install it on a new vehicle speedometer sensor.
6. Install the vehicle speedometer sensor.

Tightening torque:

7.9—10.7 N·m { 80—110 kgf·cm , 70—95 in·lbf }

7. Connect the vehicle speedometer sensor connector.
8. Install the battery carrier, air cleaner assembly and the battery.
9. Connect the negative battery cable.

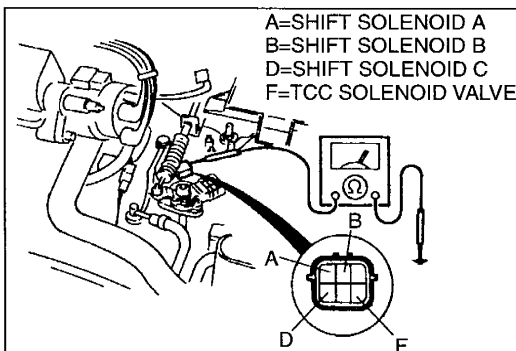

SOLENOID VALVES

Inspection

Inspection of resistance

1. Disconnect the negative battery cable.
2. Remove the battery and air cleaner assembly.
3. Disconnect the solenoid connector.
4. Measure the resistance between each terminal (A, B, D, F) and a ground.

Resistance: 13—27 Ω

5. If not as specified, replace the solenoid valve. (Refer to page K-31.)
6. Connect the solenoid connector.
7. Install the air cleaner assembly and battery.
8. Connect the negative battery cable.

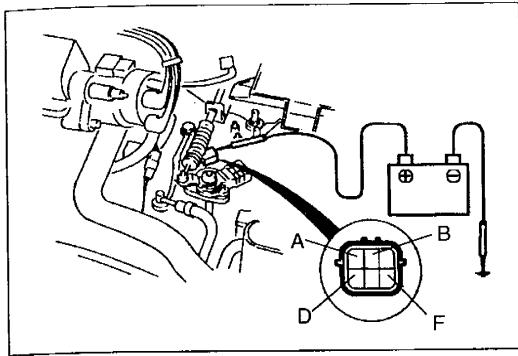
**Inspection of operation**

1. Disconnect the negative battery cable.
2. Disconnect the solenoid connector.
3. Inspect the voltage at terminals A—F and listen for a “click” sound at all solenoid valves.
4. If the “click” is not heard, replace the solenoid valve.

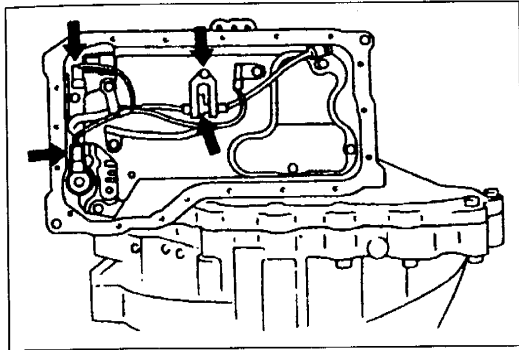
**Replacement**

1. Disconnect the solenoid connector.
2. Remove the control valve body. (Refer to page K-43.)

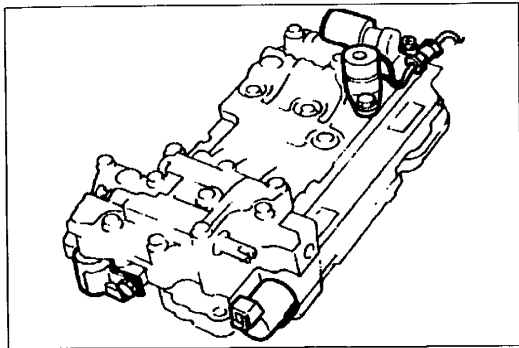

3. Remove the solenoid valve.
4. Apply ATF to a new O-ring and install it, a new solenoid valve, and the oil strainer assembly.

Tightening torque:

7.9—10.7 N·m { 80—110 kgf·cm , 70—95 in·lbf }

5. Install the control valve body. (Refer to page K-43.)

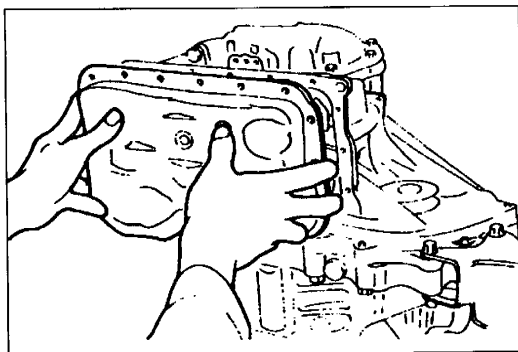

6. Lightly apply silicone sealant to both sides of a new oil pan gasket.
7. Install the new gasket and install the oil pan.

Tightening torque:

8.4—10.7 N·m { 85—110 kgf·cm , 74—95 in·lbf }

8. Connect the solenoid connector.
9. Connect the negative battery cable.
10. Carry out the time lag test and line pressure test. (Refer to page K-2.)
11. Carry out the road test. (Refer to page K-8.)

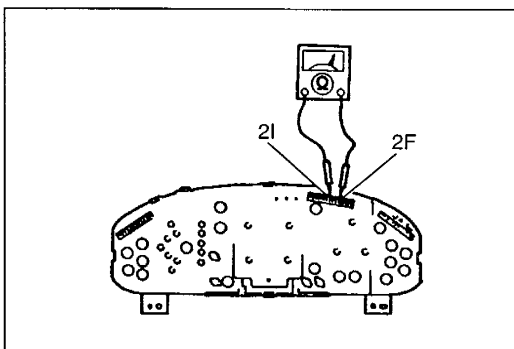
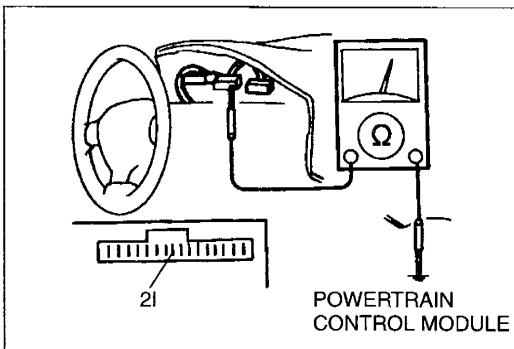
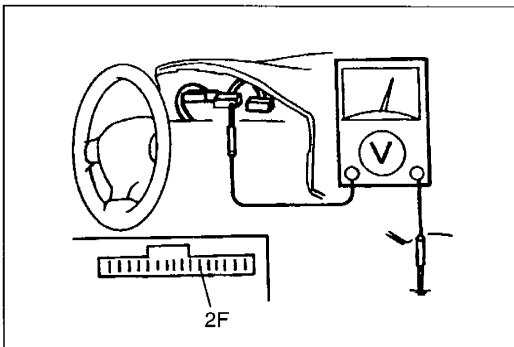
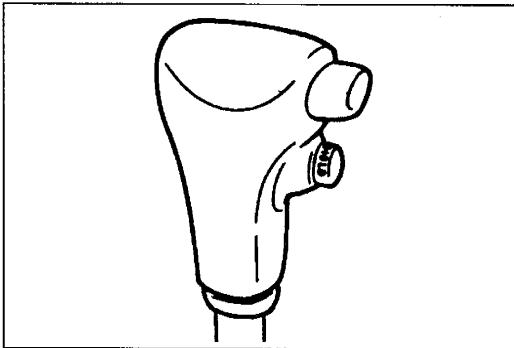
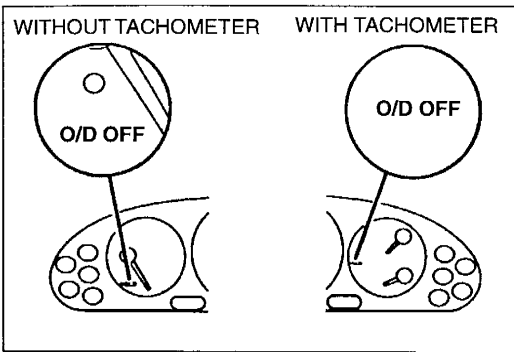

O/D OFF INDICATOR LIGHT

Inspection

Inspection of operation

1. Turn the ignition switch ON.

Note

- The O/D OFF indicator light will flash if a malfunction exists in any of the EC-AT system components.

2. Verify that O/D OFF indicator light is not illuminated.
3. Depress the switch and verify that the O/D OFF indicator light illuminates.
4. If the O/D OFF indicator light function is not as specified, check the O/D OFF switch (page K-24), and then check the terminal voltage of the O/D OFF indicator light.

Inspection of voltage

1. Remove the instrument cluster. (Refer to section T1, T2.)
2. Turn the ignition switch ON.
3. Measure voltage between terminal 2F and the ground.

B+: Battery positive voltage

Voltage	Action
B+	Go to next step
Other	<ul style="list-style-type: none"> • Replace METER fuse • Repair wiring harness (METER fuse — Instrument cluster)

Inspection of continuity

1. Disconnect the negative battery cable.
2. Disconnect the instrument cluster connector.
3. Check for continuity between terminal 2I and powertrain control module terminal 2E.

○—○: Continuity

Condition \ Terminals	2I	2E
O/D OFF switch ON	○—○	○—○
O/D OFF switch OFF		

4. If not correct, check the wiring harness (Instrument cluster — powertrain control module).
5. If correct, go to the next step.
6. Check for continuity between terminals 2I and 2F.

○—○: Continuity

Condition \ Terminals	2I	2F
Normal	○—○	○—○

7. If not correct, replace the instrument cluster or bulb.
8. Install the instrument cluster. (Refer to section T1, T2.)
9. Connect the negative battery cable.

POWERTRAIN CONTROL MODULE

Inspection

Note





- As the powertrain control module is integrated, refer to section F1, F2 for the terminal voltage.

TRANSAXLE

TRANSAXLE UNIT (REMOVAL / INSTALLATION)

Preparation

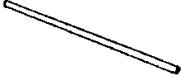
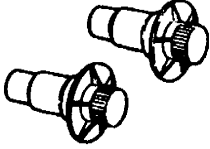
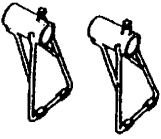
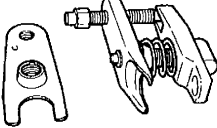
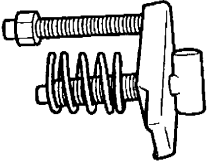
SST

49 G017 5A0 Support, engine 	For support of engine	49 G017 503 Hook (Part of 49 G017 5A0) 	For support of engine
49 G017 501 Bar (Part of 49 G017 5A0) 	For support of engine	49 G030 455 Holder, diff. side gear 	For holding side gear
49 G017 502 Support (Part of 49 G017 5A0) 	For support of engine	49 T028 3A0 Puller, Ball joint set 	For removal of tie-rod end
49 T028 303 Body (Part of 49 T028 3A0) 	For removal of tie-rod end	49 T028 304 Attachment (Part of 49 T028 3A0) 	For removal of tie-rod end

Removal / Installation

The oil pan could contain small chips, shavings, and other particles helpful in checking the condition of the transaxle and diagnosing certain problems.

To ensure that all foreign particles stay in the oil pan, make sure that the transaxle is never tipped completely over while the oil pan is still installed.

1. Disconnect the negative battery cable.
2. Raise the vehicle on a vehicle hoist.
3. Drain the ATF into a container.
4. Remove in the order shown in the figure, referring to **Removal Note**.
5. After removal, remove the oil pan to check the condition of the transaxle.
6. Install the reverse order of removal, referring to **Installation Note**.
7. Fill the transaxle with the specified ATF after installation. (Refer to page K-10.)
8. Check for leakage of ATF from all connecting points.
9. Connector the negative battery cable.
10. Check the operation of the transaxle range switch. (Refer to page K-25.)
11. Check the operation of the selector lever. (Refer to page K-52.)
12. Carry out the mechanical system test. (Refer to page K-2.)

Service item	Test item	Line pressure test	Stall test	Time lag test
Automatic transaxle replacement		○		
Automatic transaxle overhaul		○	○	○
Torque converter replacement		○	○	
Oil pump replacement		○		
Clutch system replacement		○		
Differential replacement		○		

○: Test to be performed after work

13. Carry out the road test. (Refer to page K-8.)

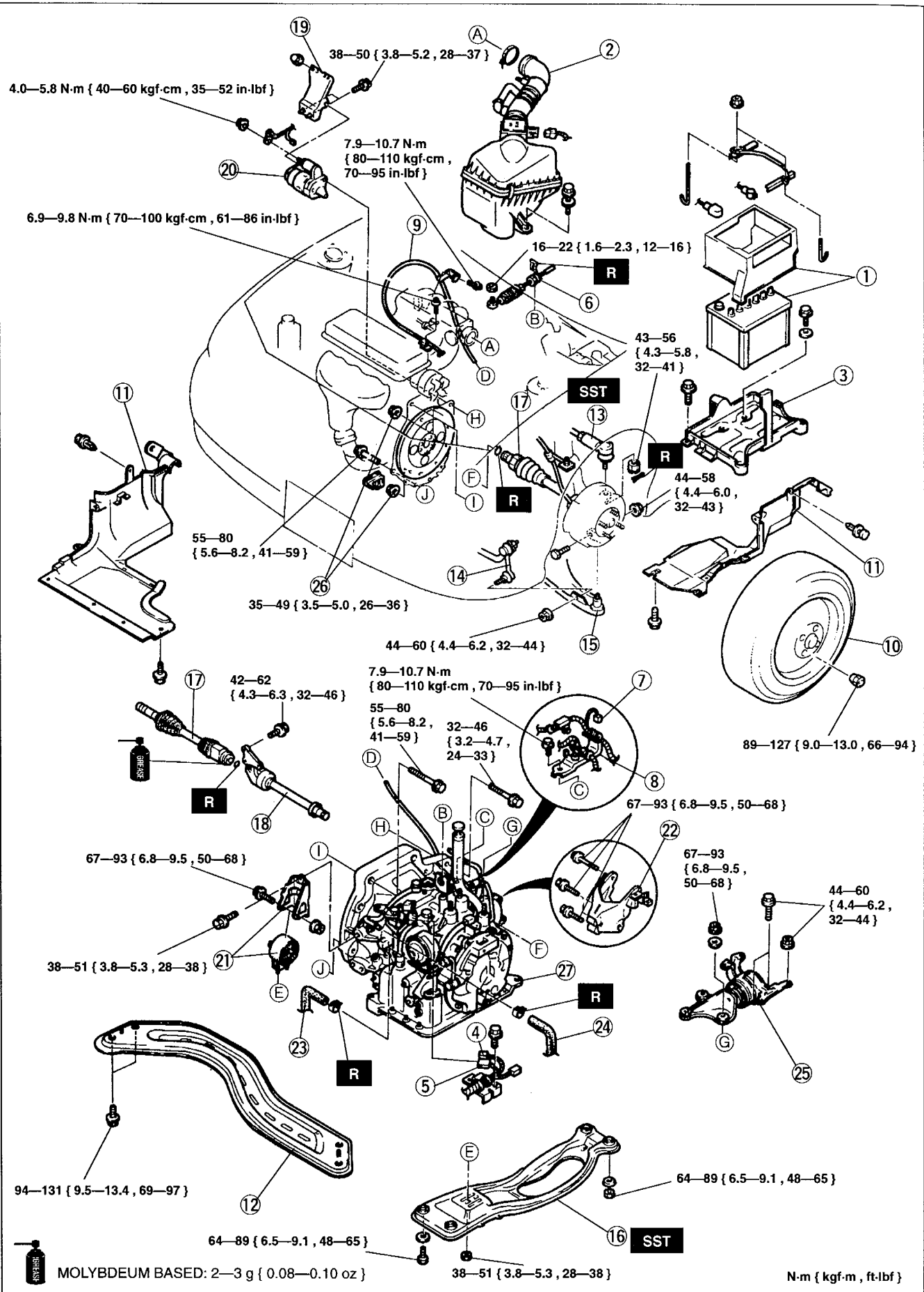

- | | |
|---|-----------|
| 1. Battery and battery cover | |
| 2. Air cleaner assembly | |
| 3. Battery carrier | |
| 4. Solenoid connector | |
| 5. Transaxle range switch connector | |
| 6. Selector cable | |
| 7. Vehicle speedometer sensor connector | |
| 8. Harness bracket | |
| 9. Throttle cable | |
| 10. Wheels and tires | |
| 11. Splash shields | |
| 12. Transverse member (BP) | |
| 13. Tie-rod end | |
| Service | section N |
| 14. Stabilizer control link | |
| 15. Lower arm | |
| Removal note | page K-37 |
| 16. Engine mounting member | |
| Removal note | page K-37 |
| Installation note | page K-41 |
| 17. Drive shaft | |
| Removal note | page K-38 |
| Installation note | page K-40 |
| 18. Joint shaft (BP) | |
| Installation note | page K-40 |
| 19. Manifold bracket | |
| 20. Starter | |
| 21. No.2 engine mount | |
| Installation note | page K-40 |
| 22. No.1 engine mount | |
| Installation note | page K-40 |
| 23. Oil hose (inner) | |
| 24. Oil hose (outer) | |
| 25. No.4 engine mount | |
| Installation note | page K-39 |
| 26. Torque converter nuts | |
| Removal note | page K-38 |
| Installation note | page K-39 |
| 27. Transaxle | |
| Removal note | page K-38 |
| Installation note | page K-39 |

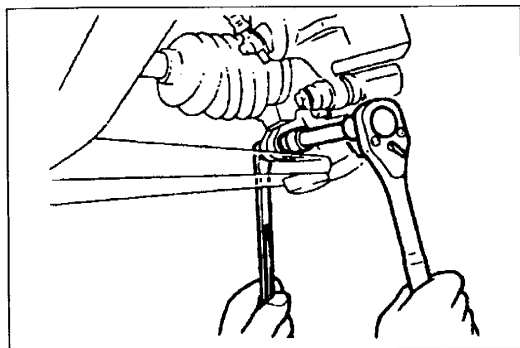

Removal note
Lower arm

1. Remove the clinch bolt from the lower arm ball joints.

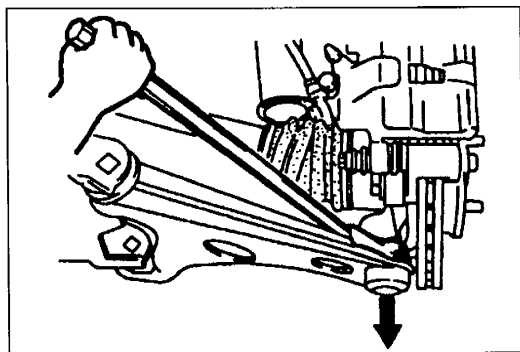

Caution

- Wrap a rag around the ball joint dust seal to protect it from damage.
2. Pry the lower arm out of the knuckle.

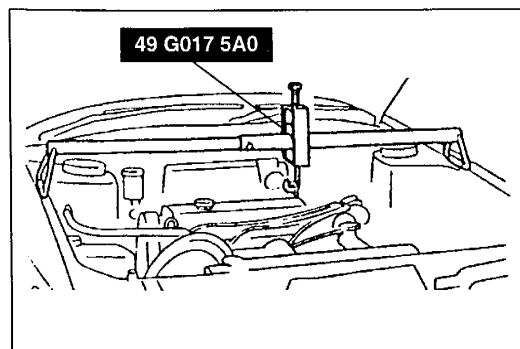

Engine mounting member

1. Support the engine by using the SST before removing the engine mounting member.
2. Remove the engine mounting member.

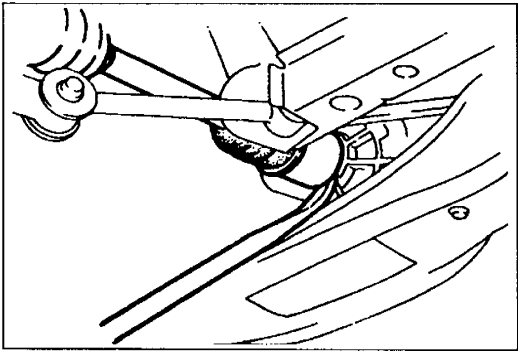

Drive shafts

Caution

- The oil seal is easily damaged by the sharp edges of the drive shaft splines. Do not let the splines contact the oil seal.

1. Separate the right side drive shaft from the transaxle by prying with a bar inserted between the outer ring and the transaxle.
2. Suspend the drive shaft by using a rope.
3. Install the **SST** into the transaxle to hold the side gears.

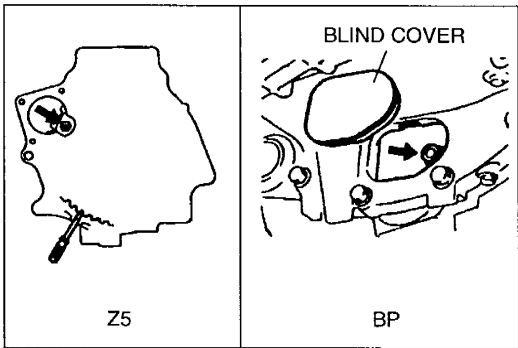
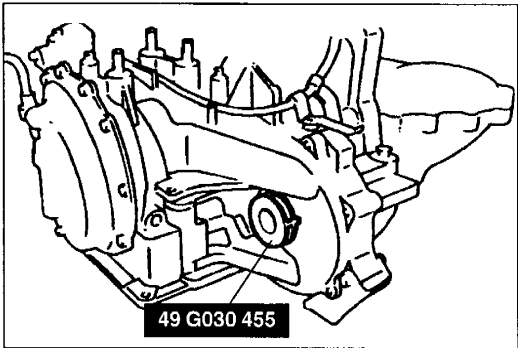

Torque converter nuts

Hold the drive plate and remove the torque converter nuts.

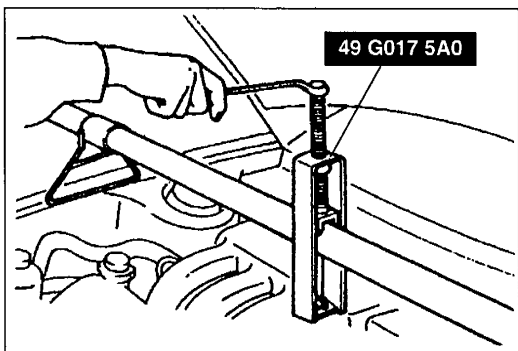

Transaxle

1. Loosen the **SST** and lean the engine toward the transaxle.
2. Support the transaxle on a jack, making sure that it does not fall from the jack.

Caution

- Do not allow the transaxle to lean toward the torque converter side.

3. Remove the transaxle mounting bolts.
4. Remove the transaxle.

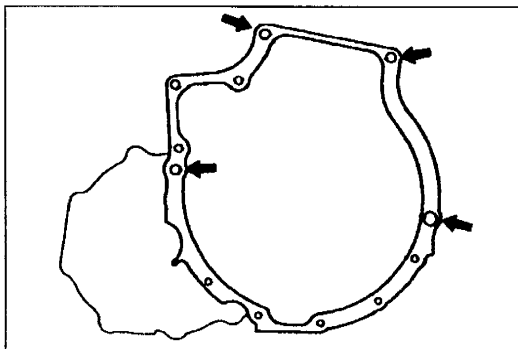

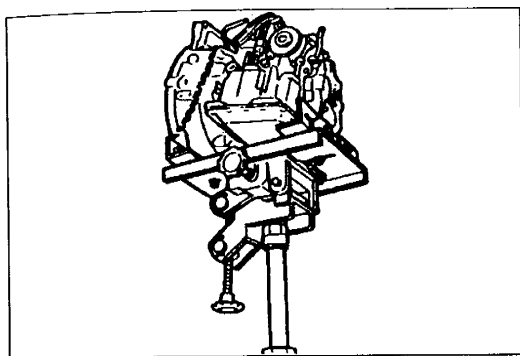

Installation note
Transaxle

1. Set the transaxle on a jack and make sure that it does not fall.

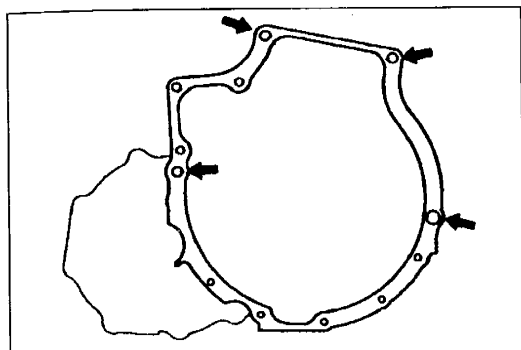

2. Install the transaxle mounting bolts.

Tightening torque:

55—80 N·m { 5.6—8.2 kgf·m , 41—59 ft·lbf }

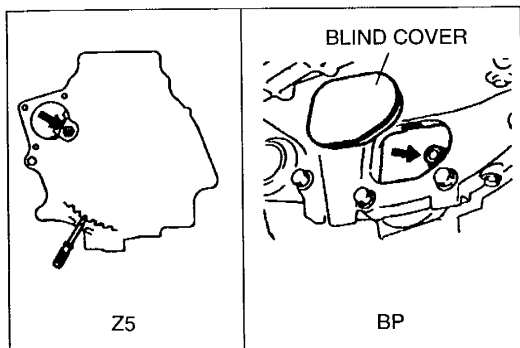

Torque converter nuts

Hold the drive plate and install the torque converter nuts.

Tightening torque:

35—49 N·m { 3.5—5.0 kgf·m , 26—36 ft·lbf }

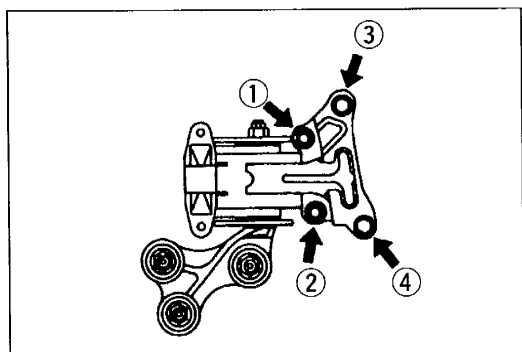

No.4 engine mount

1. Install the No.4 engine mount.
2. Hand-tighten the nuts of transaxle side.
3. Tighten the nuts and bolts of the body side, as shown in the figure.

Tightening torque:

44—60 N·m { 4.4—6.2 kgf·m , 32—44 ft·lbf }

4. Tighten the nuts on the transaxle side.

Tightening torque:

67—93 N·m { 6.8—9.5 kgf·m , 50—68 ft·lbf }

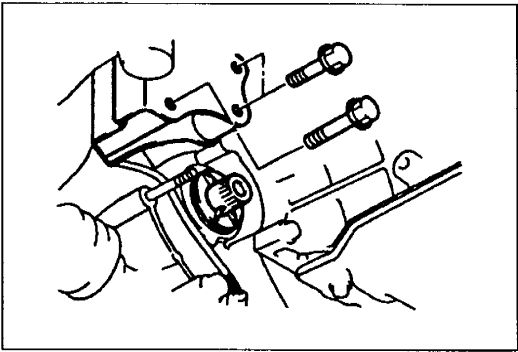

No.1 engine mount

Caution

- Misaligning the bolts will cause damage to the bolt holes.

1. Use the **SST** (49 G017 5A0) to make sure the transaxle bolt holes and the No.1 engine mount meet evenly.
2. After the 3 bolts are set in the holes, tighten the bolts to the specified torque.

Tightening torque:

67—93 N·m { 6.8—9.5 kgf·m , 50—68 ft·lbf }

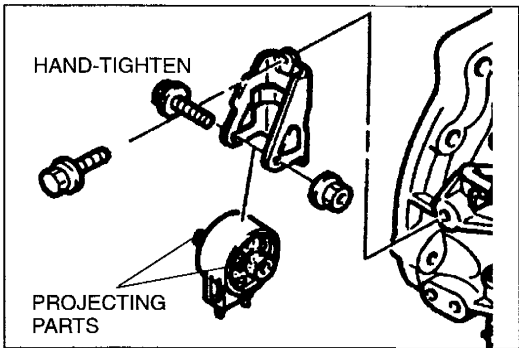

No.2 engine mount

1. Install the engine mount bracket to the transaxle, as shown in the figure.

Tightening torque:

38—51 N·m { 3.8—5.3 kgf·m , 28—38 ft·lbf }

2. Hand-tighten the nuts and bolts of the engine mount rubber.

Tightening torque:

67—93 N·m { 6.8—9.5 kgf·m , 50—68 ft·lbf }

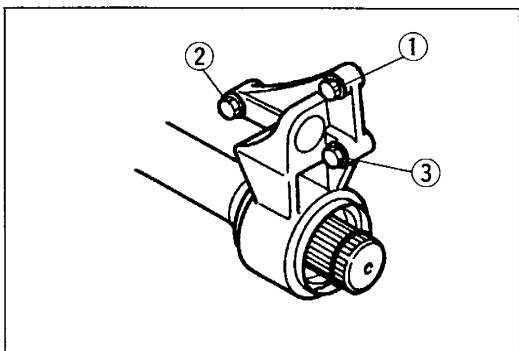

Joint shaft (BP)

1. Insert the joint shaft to the transaxle.
2. Install the joint shaft to the cylinder block and tighten the bolts in the order shown.

Tightening torque:

42—62 N·m { 4.3—6.3 kgf·m , 32—46 ft·lbf }

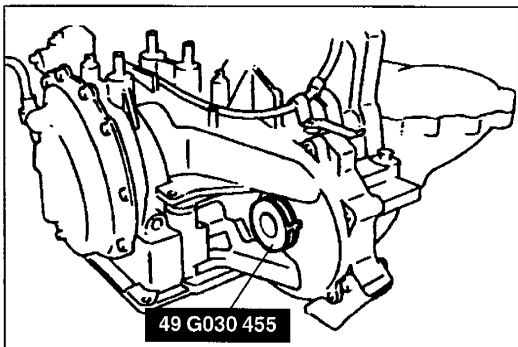

Drive shafts

1. Inspect the oil seal for damage.

Caution

- The oil seal is easily damaged by the sharp edges of the drive shaft splines. Do not let the splines contact the oil seal.

2. Remove the **SST** from the transaxle case.

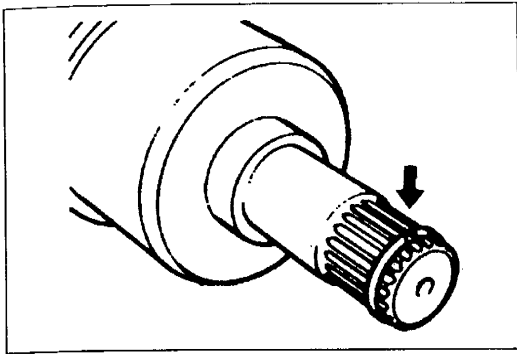

3. Install the clip with the ends facing upward.
(Refer to section N.)

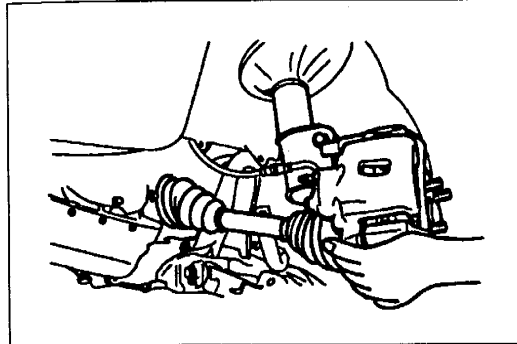

4. Apply ATF to the oil seal lip. Install the drive shaft.
5. Verify that the drive shaft is correctly seated by pulling on the shaft. It must not slide out.

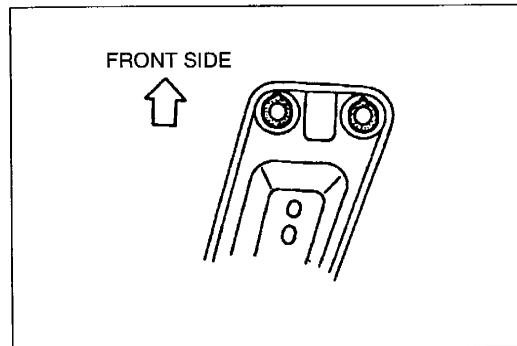

Engine mounting member

Note

- Verify that the engine mount rubbers are installed as shown.
- Put the No.2 engine mount stud bolts in the installation holes when installing the engine mounting member.

1. Install the bolts and nuts as shown.

Tightening torque

- Ⓐ: 64—89 N·m { 6.5—9.1 kgf·m , 48—65 ft·lbf }
- Ⓑ: 38—51 N·m { 3.8—5.3 kgf·m , 28—38 ft·lbf }

2. Tighten the No.2 engine mount rubber nut and bolt.

Tightening torque:

- 67—93 N·m { 6.8—9.5 kgf·m , 50—68 ft·lbf }

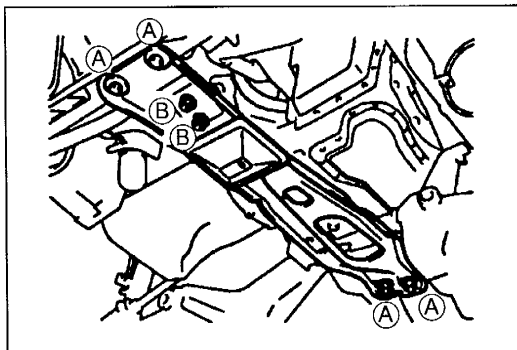

3. Remove the SST (49 G017 5A0).



OIL SEAL (TRANSAXLE)

Preparation

SST

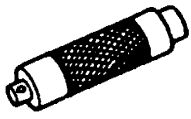
<p>49 G030 795</p> <p>Installer, oil seal</p> 	<p>For installation of oil seal</p>	<p>49 G030 796</p> <p>Body (Part of 49 G030 795)</p> 	<p>For installation of oil seal</p>
<p>49 G030 797</p> <p>Handle (Part of 49 G030 795)</p> 	<p>For installation of oil seal</p>	<p>—</p>	<p>—</p>

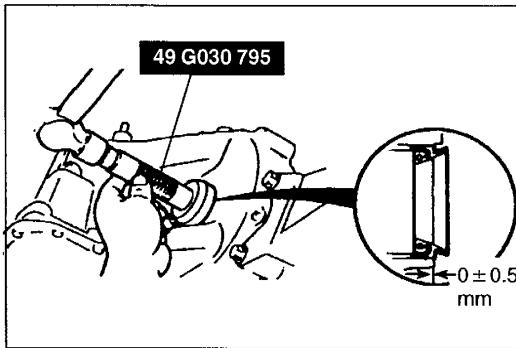



On-vehicle Replacement

1. Remove the drive shaft and joint shaft. (Refer to page K-34.)
2. Remove the oil seal.
3. Using the **SST** and a hammer, tap a new oil seal in evenly until the **SST** contacts the transaxle case.
4. Coat the lip of the oil seal with ATF.
5. Install the drive shaft and joint shaft. (Refer to page K-34.)
6. Carry out the line pressure test. (Refer to page K-3.)
7. Carry out the road test. (Refer to page K-8.)

CONTROL VALVE BODY (ON-VEHICLE REMOVAL / INSTALLATION)

Preparation

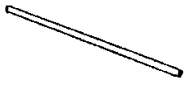
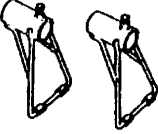
SST

<p>49 G017 5A0</p> <p>Support, engine</p> 	<p>For support of engine</p>	<p>49 G017 501</p> <p>Bar (Part of 49 G017 5A0)</p> 	<p>For support of engine</p>
<p>49 G017 502</p> <p>Support (Part of 49 G017 5A0)</p> 	<p>For support of engine</p>	<p>49 G017 503</p> <p>Hook (Part of 49 G017 5A0)</p> 	<p>For support of engine</p>

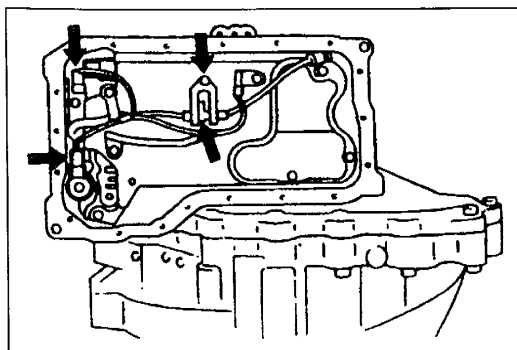
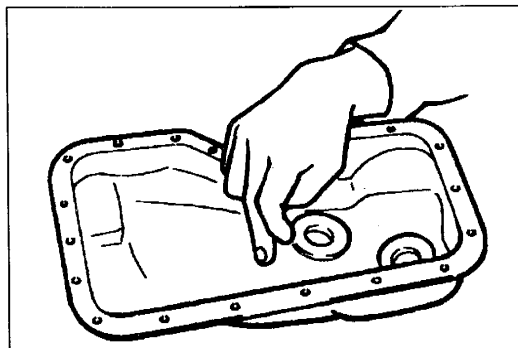
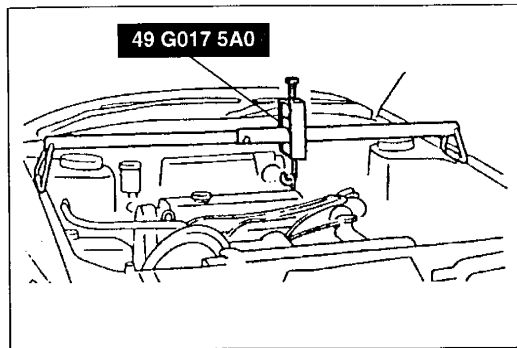

On-vehicle Removal

Warning

- Using compressed air can cause dirt and other particles to fly out, causing injury to the eyes. Wear eye protection when using compressed air to clean components.

1. Clean the transaxle exterior thoroughly with a steam cleaner or cleaning solvent before removal.
2. Disconnect the negative battery cable.
3. Support the engine by using the **SST**.
4. Jack up the vehicle and support it with safety stands.
5. Drain the ATF into a container.
6. Remove the transverse member. (BP)
7. Remove the engine mounting member.
8. Remove the oil pan and gasket.

9. Disconnect the solenoid connectors.

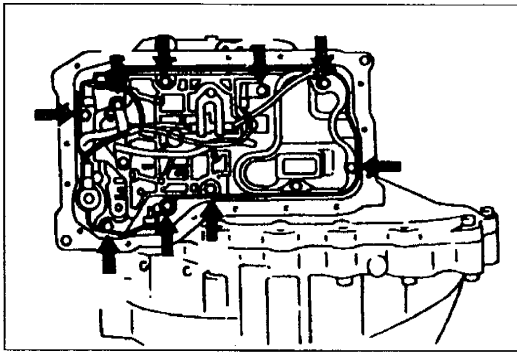

10. Remove the bolts as shown in the figure.
11. Remove the control valve body.

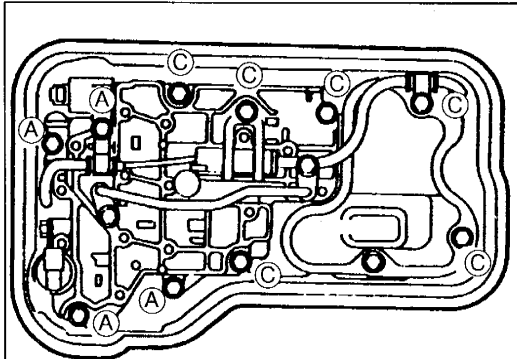

On-vehicle Installation

1. Install the control valve body as shown.

Tightening torque:

7.9—10.7 N·m { 80—110 kgf·cm , 70—95 in·lbf }

2. Connect the solenoid connectors.
3. Apply a thin coat of silicone sealant to both sides of a new gasket.
4. Install the gasket and the oil pan.

Tightening torque:

7.9—10.7 N·m { 80—110 kgf·cm , 70—95 in·lbf }

Bolt length (measured from below the head)

Ⓐ: 30 mm { 1.18 in }

Ⓒ: 50 mm { 1.97 in }

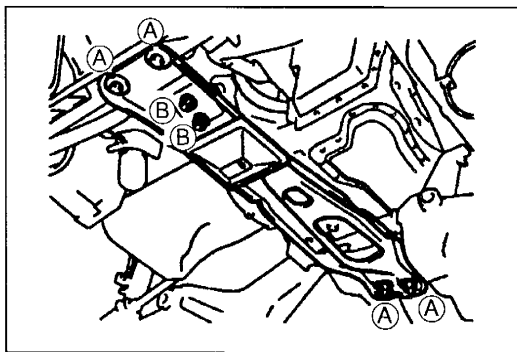
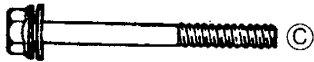

5. Install the engine mounting member.
6. Loosely install bolts Ⓐ and Ⓑ.

Tightening torque

Ⓐ: 64—89 N·m { 6.5—9.1 kgf·m , 48—65 ft·lbf }

Ⓑ: 38—51 N·m { 3.8—5.2 kgf·m , 28—37 ft·lbf }

7. Install the transverse member. (BP)

Tightening torque:

94—131 N·m { 9.5—13.4 kgf·m , 69—97 ft·lbf }

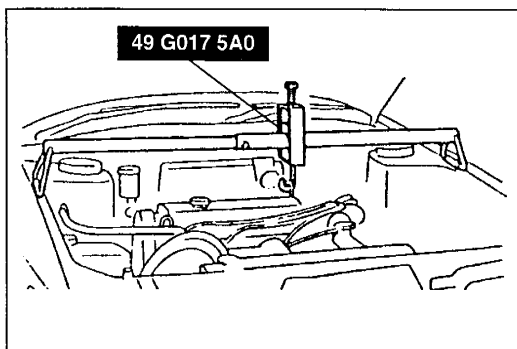

8. Remove the **SST** from the engine.
9. Pour in ATF and, with the engine idling, check the ATF level and check for leaks. (Refer to page K-10.)
10. Carry out the time lag test and line pressure test. (Refer to page K-2.)
11. Carry out the road test. (Refer to page K-8.)

OIL COOLER

OIL COOLER

Removal / Installation

1. Disconnect the negative battery cable.
2. Remove in the order shown in the figure.
3. Install in the reverse order of removal, referring to **Installation Note**.
4. Add ATF to the specified level.
5. Connect the negative battery cable.
6. Inspect for oil leakage from the oil pipes and oil hoses.
7. Inspect the ATF level and condition. (Refer to page K-10.)
8. Carry out the line pressure test. (Refer to page K-2.)
9. Carry out the road test. (Refer to page K-8.)

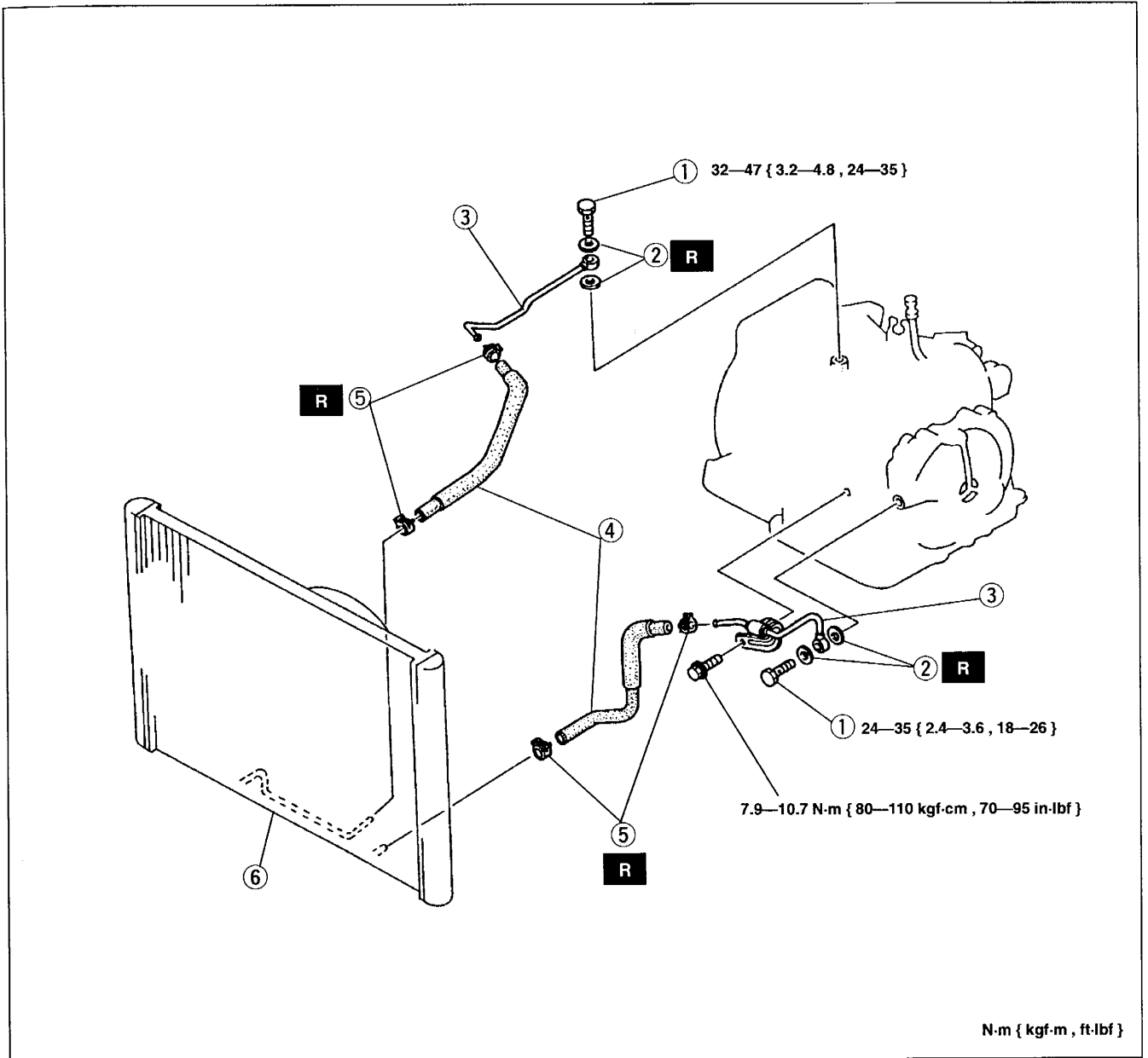

- 1. Connector bolts
- 2. Washers
- 3. Oil pipe
- 4. Oil hose

- 5. Hose clamp
- 6. Radiator

Installation note page K-46

Service section E

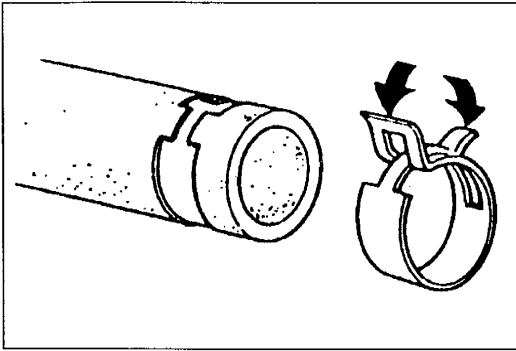

**Installation note****Oil hose**

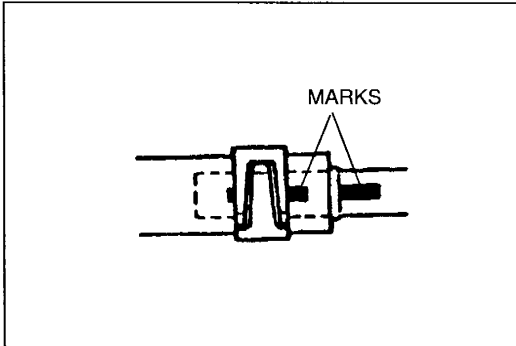
1. Align the marks, and slide the oil hose onto the oil pipe until it is fully seated as shown.
2. Install the hose clamp onto the hose. If reusing the hose, install the new hose clamp exactly into the mark left by the previous hose clamp.
3. Verify that the hose clamp does not interfere with any other parts.

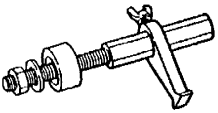
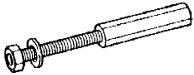

DRIVE PLATE

**PREPARATION
SST**

<p>49 E011 1A0 Brake set, ring gear</p> 	<p>For holding drive plate</p>	<p>49 E011 103 Shaft (Part of 49 E011 1A0)</p> 	<p>For holding drive plate</p>
<p>49 E011 104 Collar (Part of 49 E011 1A0)</p> 	<p>For holding drive plate</p>	<p>49 E011 105 Stopper (Part of 49 E011 1A0)</p> 	<p>For holding drive plate</p>

**DRIVE PLATE
Removal / Installation**

1. Remove in the order shown in the figure, referring to **Removal Note**.
2. Install in the reverse order of removal, referring to **Installation Note**.

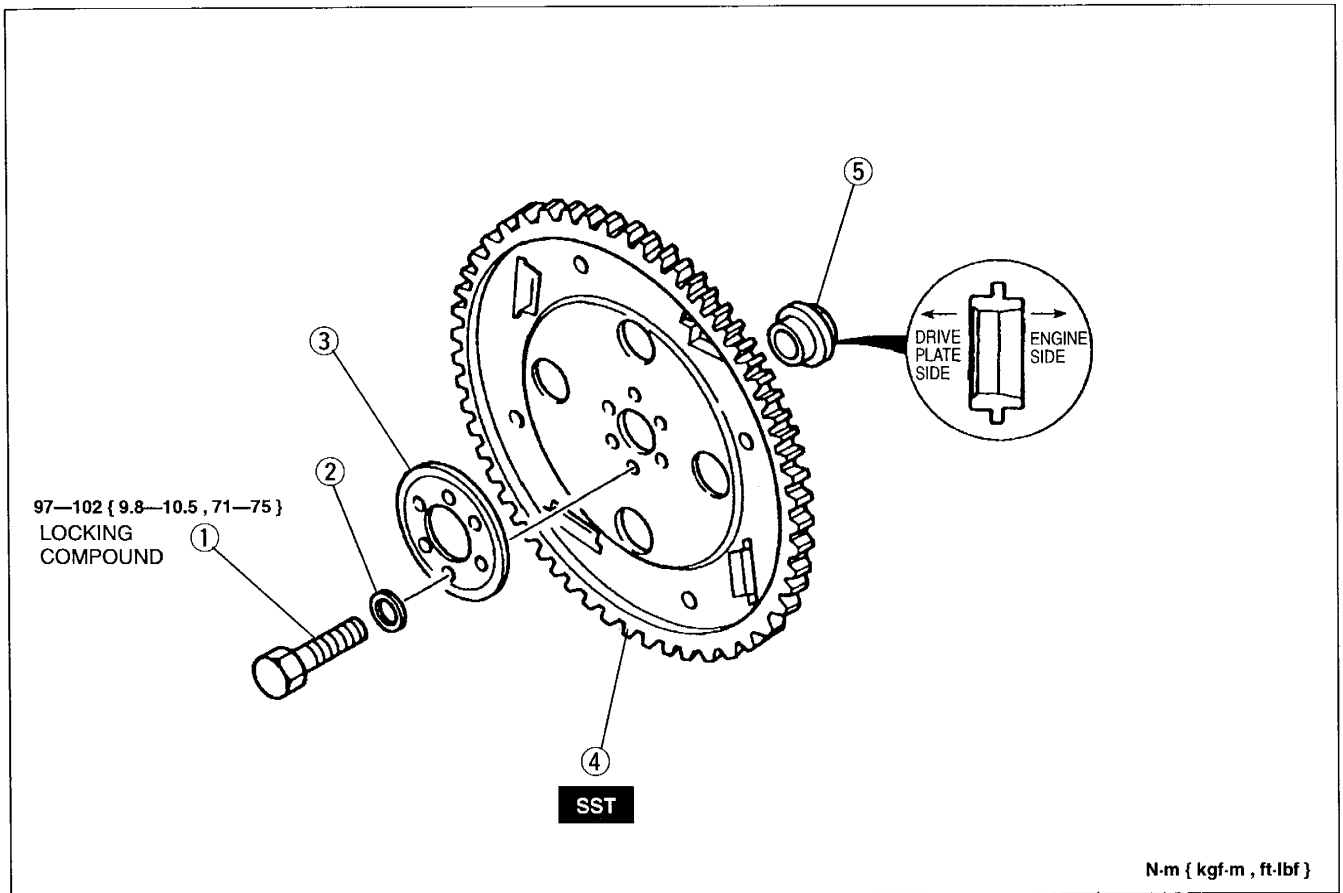

1. Bolts
2. Washers
3. Backing plate

4. Drive plate
Removal note page K-48
Installation note page K-48
5. Adapter

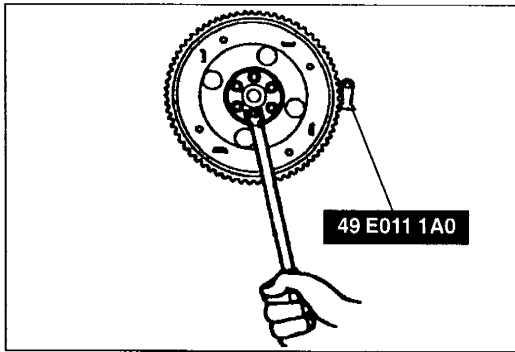
**Removal note****Drive plate**

1. Set the **SST** against the drive plate.
2. Remove the bolts and the drive plate.

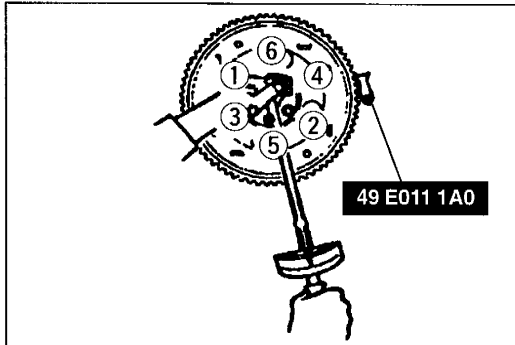
**Installation note****Drive plate**

1. Set the **SST** against the drive plate.
2. Gradually tighten the drive plate mounting bolts in the order shown.

Tightening torque:

97—102 N·m { 9.8—10.5 kgf·m , 71—75 ft·lbf }

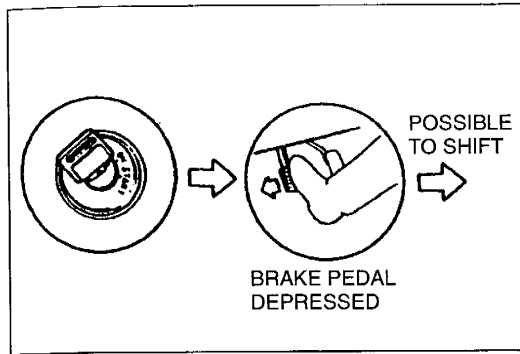

SHIFT MECHANISM

SHIFT-LOCK

Inspection

1. Turn the ignition switch to ON (engine OFF).
2. Verify that the selector lever is in P position.
3. Without the brake pedal depressed, verify that the selector lever cannot be shifted from P position.
4. Depress the brake pedal and verify that the selector lever can be shifted from P position.
5. If not as specified, check the P position switch continuity and/or shift-lock actuator terminal voltage and continuity. (Refer to pages K-51.)

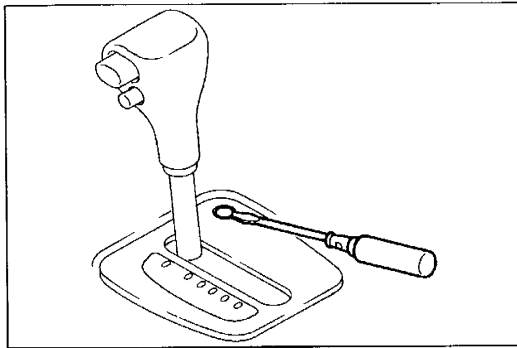

EMERGENCY OVERRIDE BUTTON

Inspection

1. Turn the ignition switch to OFF.
2. Verify that the selector lever is in P position.
3. Without the brake pedal depressed, verify that the selector lever cannot be shifted from P position.
4. Remove the cover on the indicator panel by using a screwdriver.
5. Insert a screwdriver into the emergency override button and push down. Verify that the selector lever can be shifted from P position.
6. If not as specified, replace the emergency override button.

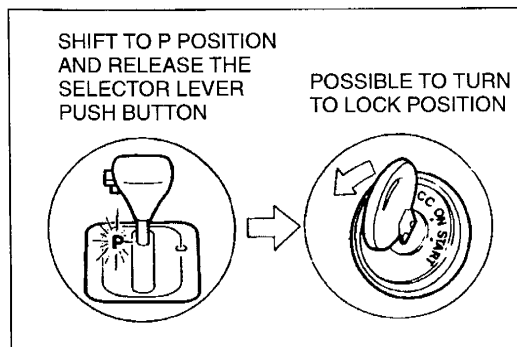
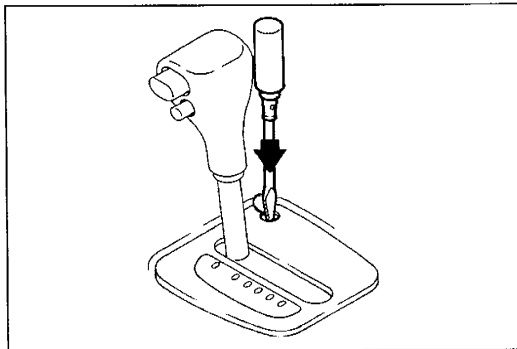

KEY INTERLOCK

Inspection

1. Turn the ignition switch to ON (engine OFF).
2. Shift the selector lever to R position.
3. Verify that the ignition key cannot be turned to LOCK position.
4. Shift the selector lever to P position.
5. Verify that the ignition key can be turned to LOCK position.
6. If not as specified, inspect and repair as necessary.

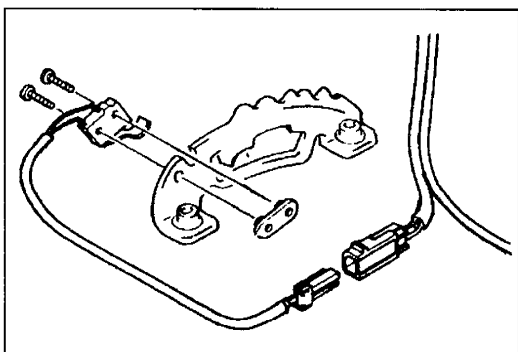
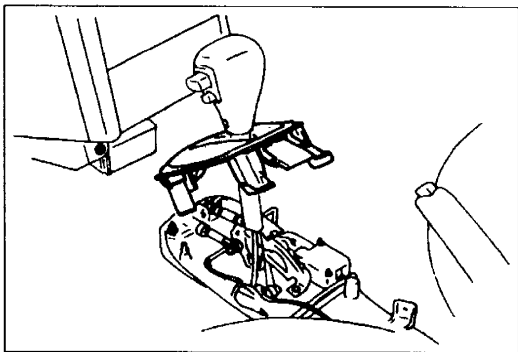
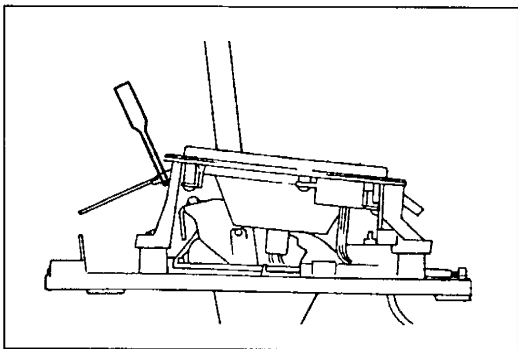
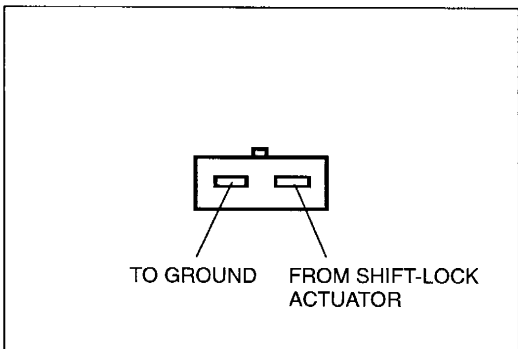
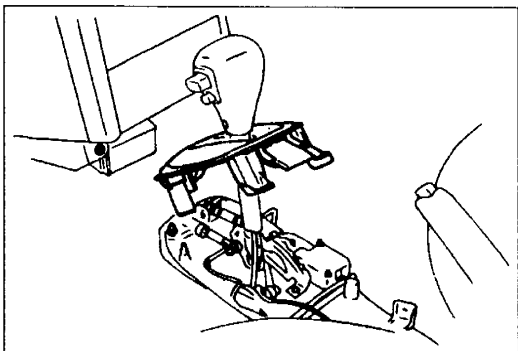

P POSITION SWITCH

Inspection

1. Disconnect the negative battery cable.
2. Remove the rear console and front console.
3. Remove the indicator panel screws and lift up the indicator panel.
4. Disconnect the P position switch connector.
5. Check for continuity between the terminals.

Position/Range	Selector lever release button	Continuity
P	Released	Yes
	Depressed	No
Except P	—	No

6. If not as specified, replace the P position switch.
7. Connect the connector.
8. Install and adjust the indicator panel.
(Refer to page K-52.)
9. Install the front console and rear console.
10. Connect the negative battery cable.
11. Check for correct operation of the shift-lock system.
(Refer to page K-49.)

Replacement

1. Disconnect the negative battery cable.
2. Remove the rear console and front console.
3. Remove the indicator panel screws and lift up the indicator panel.
4. Disconnect the connector.
5. Remove the P position switch.
6. Install a new P position switch.
7. Connect the connector.
8. Install and adjust the indicator panel.
(Refer to page K-52.)
9. Install the front console and rear console.
10. Connect the negative battery cable.
11. Check for correct operation of the shift-lock system.
(Refer to page K-49.)

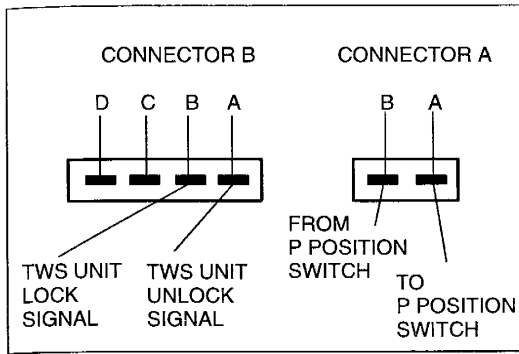

SHIFT-LOCK ACTUATOR

Inspection

1. Remove the rear console and front console.
2. Shift the selector lever to P position.
3. Turn the ignition switch to ON (engine OFF), and check for terminal voltage and continuity, referring to the chart on page K-51 as follows.

B+: Battery positive voltage

Check terminal		⊖ Probe connected to		Measurement type	Condition	Measurement value
Connector	Terminal	Connector	Terminal			
B	A	Body		Voltage (V)	Brake pedal released→depressed	0→B+
B	B	Body		Voltage (V)	Except P position→P position	0→B+
A	A	B	B	Continuity	Selector lever release button released	Continuity
A	B	B	B	Continuity	Constant	Continuity

4. If not as specified, repair the wiring harness and/or replace the shift-lock actuator.
5. Install the front console and rear console.
6. Verify correct operation of the shift-lock system. (Refer to page K-49.)

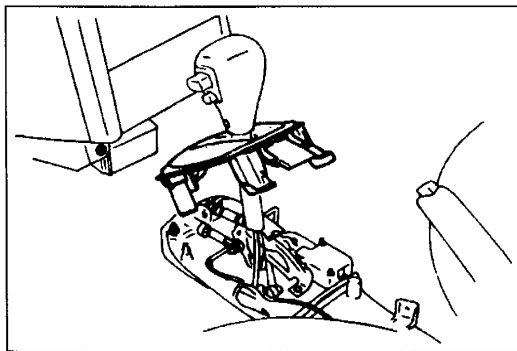

Replacement

1. Disconnect the negative battery cable.
2. Remove the rear console and front console.
3. Remove the indicator screws and lift up the indicator panel.
4. Disconnect the shift-lock actuator connector.
5. Disconnect the P position switch connector.
6. Remove the shift-lock actuator.
7. Install a new shift-lock actuator.

Tightening torque:

1.3—1.8 N·m { 13—19 kgf·cm , 12—16 in·lbf }

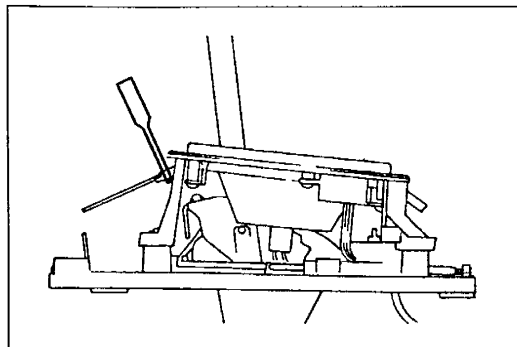

8. Connect the P position switch connector.
9. Connect the shift-lock actuator connector.
10. Install and adjust the indicator panel. (Refer to page K-52.)
11. Install the front console and rear console.
12. Connect the negative battery cable.
13. Verify correct operation of the shift-lock system. (Refer to page K-49.)

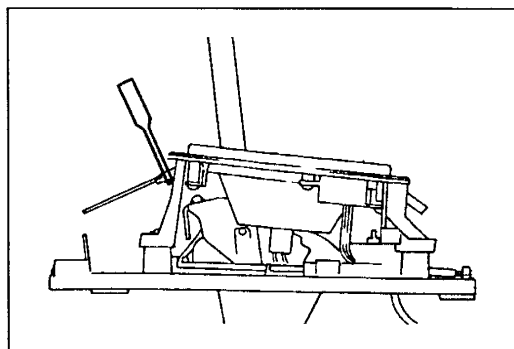
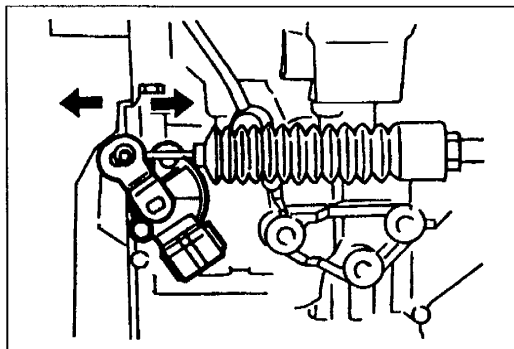
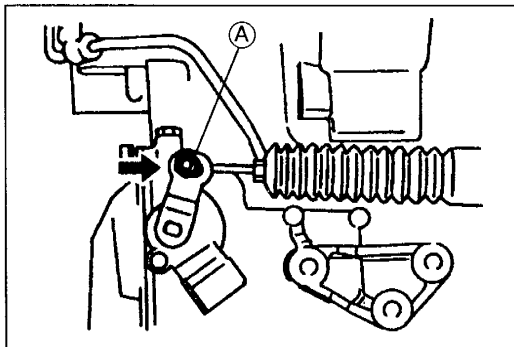
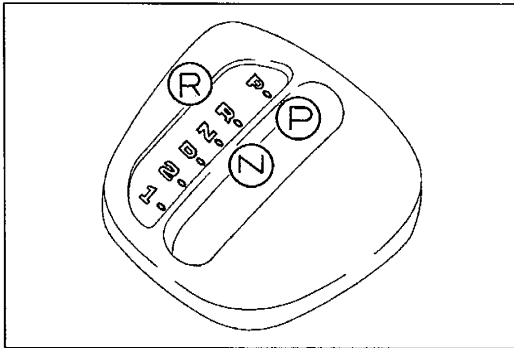
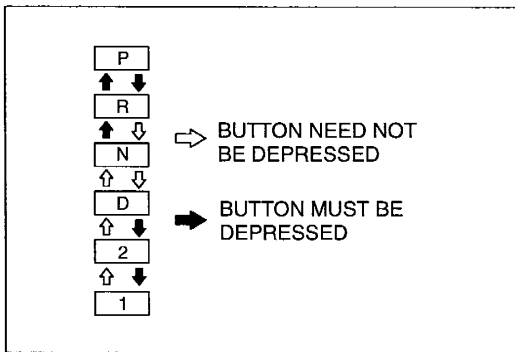

SELECTOR LEVER

Inspection

1. Turn the ignition switch to ON (engine OFF).
2. With the brake pedal depressed, verify that there is a "click" at each range when shifted in the pattern shown.
3. Verify that the selector lever can only be shifted as shown.
4. Verify that there is a "click" at each range position when shifted from P position to 1 range.
5. Verify that the position of the selector lever and the selector illumination light are aligned.
6. If not as specified, adjust the indicator panel as follows.
7. Verify that the vehicle operates in each selected range.

Adjustment

Selector cable

1. Remove the battery, air cleaner assembly, and battery carrier.
2. Shift the selector lever to P position.
3. Loosen nut (A) as shown in the figure.
4. Push the selector cable in the direction of the arrow until it doesn't move any further.
5. Position the selector cable so that there is no load in the direction of the arrows, and tighten the nut.

Tightening torque:

16—22 N·m { 1.6—2.3 kgf·m , 12—16 ft·lbf }

6. Install the battery carrier, air cleaner assembly, and battery.
7. Shift the selector lever from P position to 1 range, and make sure that there is no interference from other components in that area.

Indicator panel

1. Shift the selector lever to P position.
2. Loosen the indicator panel screws.
3. Align the alignment screw in the slider with the holes in the indicator panel. Install suitable heavy-gauge wire to hold the slider.

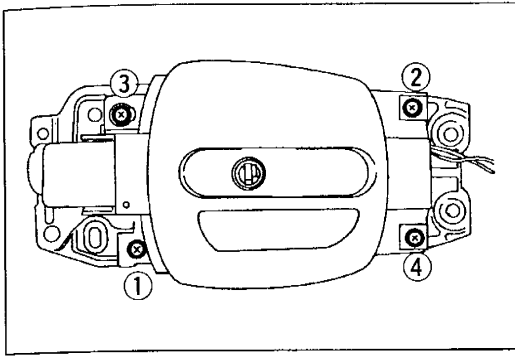

4. Tighten the indicator panel screws in the order shown in the figure.

Tightening torque:

2.0—2.9 N·m { 20—30 kgf·cm , 18—26 in·lbf }

5. Remove the wire.
6. Verify that the selector lever properly aligns with the indicator in all ranges and positions.

Removal / Installation

1. Disconnect the negative battery cable.
2. Remove in the order shown in the figure.
3. Install in the reverse order of removal, referring to **Installation Note**.
4. Connect the negative battery cable.
5. Verify correct operation of the shift-lock system. (Refer to page K-49.)

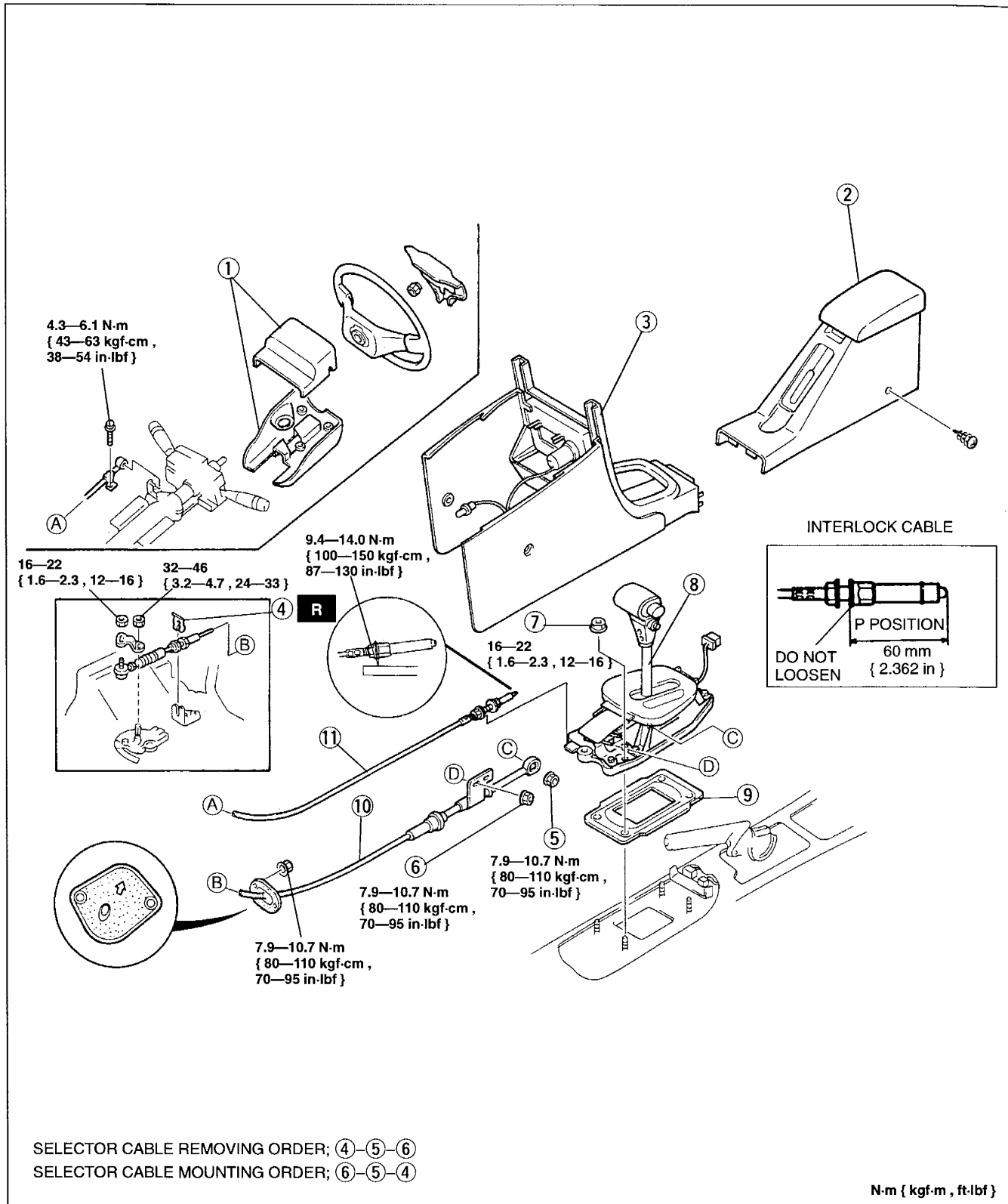

- | | |
|-----------------------------------|--|
| 1. Steering column cover | 8. Selector lever |
| 2. Rear console | Inspection page K-52 |
| 3. Front console | Adjustment page K-52 |
| 4. Clip | Disassembly / Assembly page K-57 |
| Installation note page K-56 | 9. Insulator |
| 5. Nut | 10. Selector cable |
| 6. Nut | 11. Interlock cable |
| Installation note page K-55 | Installation note page K-55 |
| 7. Nut | |

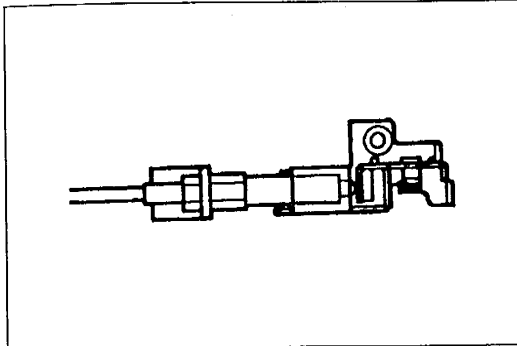

Installation note
Interlock cable

- Shift the selector lever from P position to 1 range.
- Install the interlock cable so that the tip touches the operating lever.

Caution

- Do not damage the outer sleeve (A) when pulling or turning the interlock cable.

- Install the interlock cable into the bracket groove, then tighten the nut.

Tightening torque:

9.9—14.0 N·m { 100—150 kgf·cm , 87—130 in·lbf }

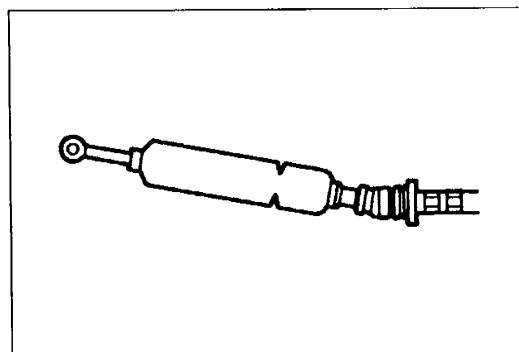
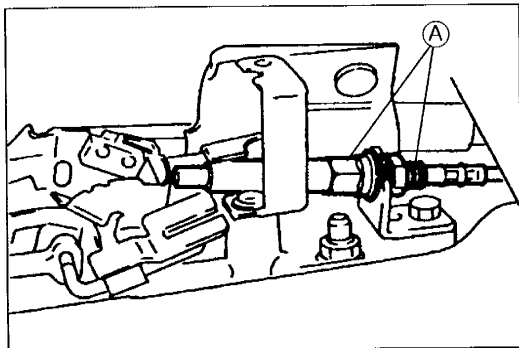

Nut

- Shift the selector lever and manual shaft to P position.

Caution

- Bending the selector cable in the manner shown in the figure will damage the cable and cause it to become loose during shifting. When handling and installing the selector cable, hold it straight.

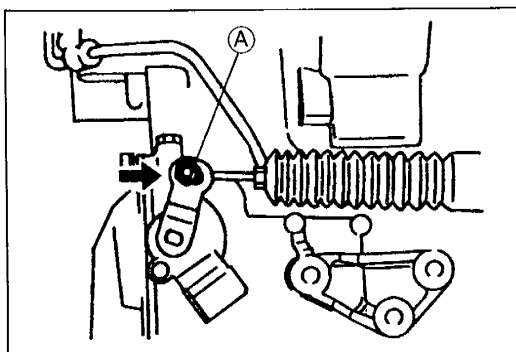

- After verifying that the selector cable boot is not twisted, install the selector cable to the selector lever, then tighten nut (A).

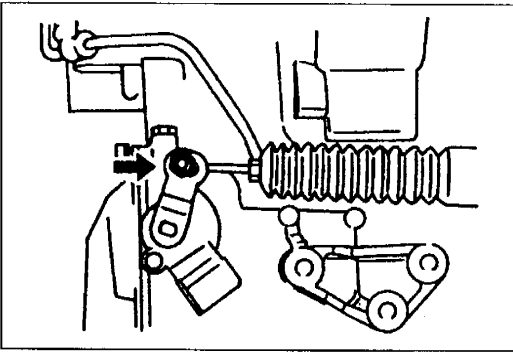

3. Push the selector cable in the direction of the arrow until it doesn't move any further.

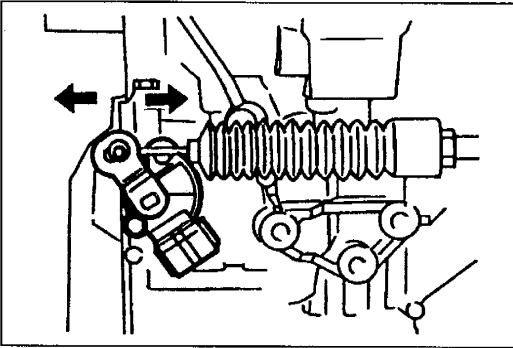

4. Position the selector cable so that there is no load in the direction of the arrows, and tighten the nut.

Tightening torque:

16—22 N·m { 1.6—2.3 kgf·m , 12—16 ft·lbf }

5. Shift the selector lever from P position to 1 range, and make sure that there is no interference from other components in that area.

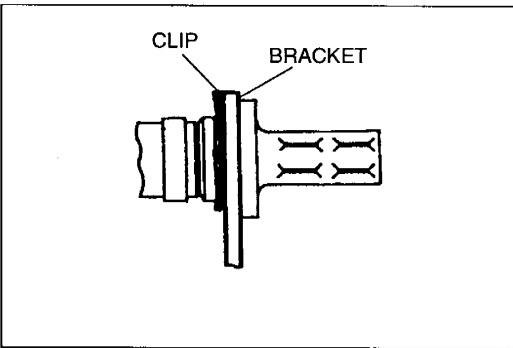

Clip

Install a new clip flush to the selector cable bracket.

Disassembly / Assembly

1. Disassemble in the order shown in the figure, referring to **Disassembly Note**.
2. Assemble in the reverse order of disassembly, referring to **Assembly Note**.

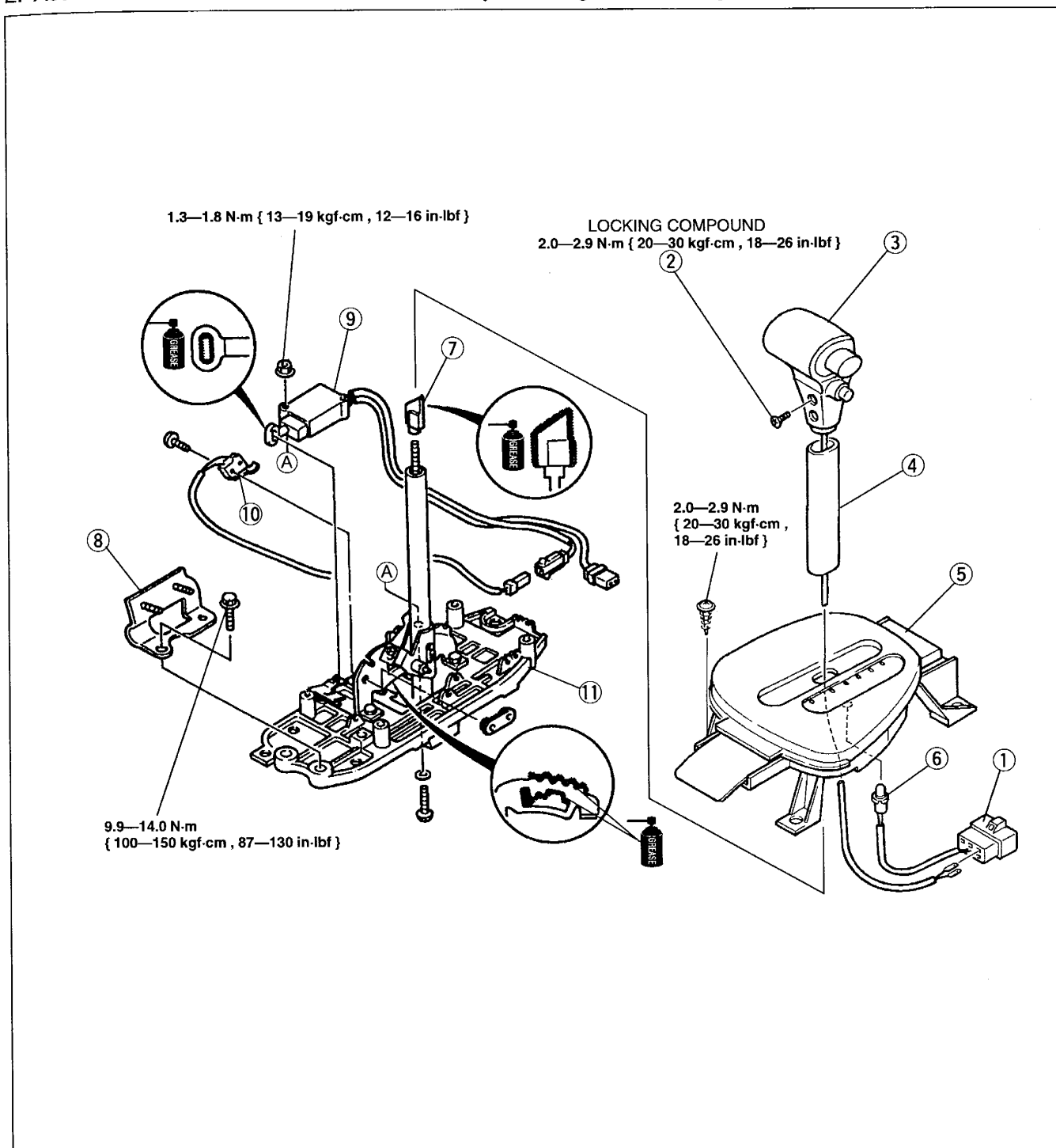

1. Connector
Disassembly note page K-58
2. Screws
3. Selector lever knob
4. Cover
5. Indicator panel
Assembly note page K-58
6. Selector illumination light

7. Cam
Assembly note page K-58
8. Selector cable bracket
9. Shift-lock actuator
Inspection page K-51
10. P position switch
Inspection page K-50
11. Selector lever

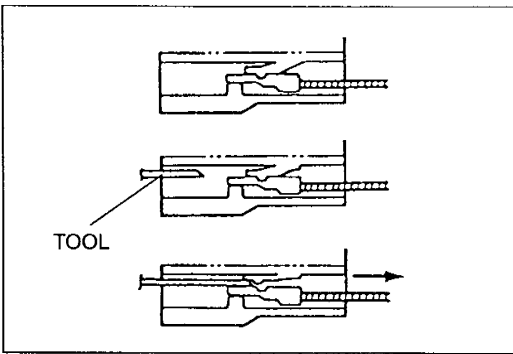
**Disassembly note****Connector**

1. Insert a thin piece of metal from the terminal side of the connector, and press down the terminal locking tab.
2. Pull the terminal out of the connector.

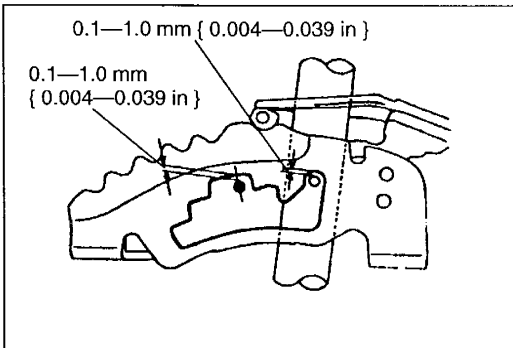
**Assembly note****Cam**

1. Loosely install the cam to the push rod.
2. Adjust the clearance between the guide plate and the guide pin by turning the cam.
3. Clearance can be made smaller by turning the cam clockwise.
4. Install the selector lever knob and verify that the clearance is as specified.
5. If the clearance is not as specified, repeat from Step 2.
6. Remove the selector lever knob.
7. Apply grease to the cam as shown.

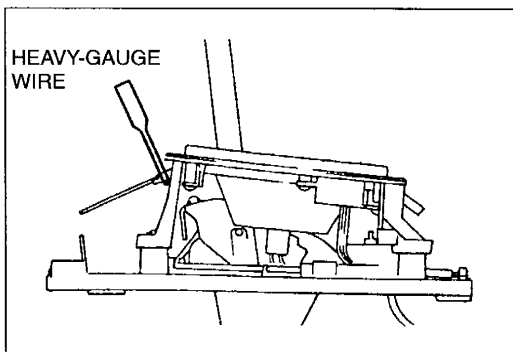
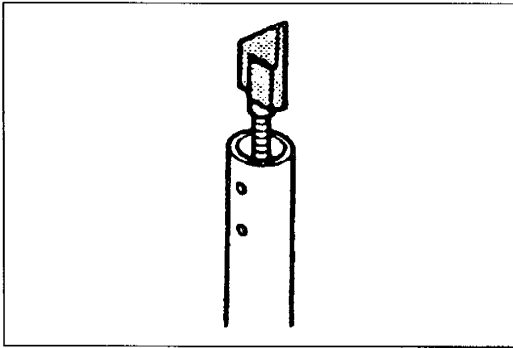
**Indicator panel**

1. Shift the selector lever to P position.
2. Align the alignment screws in the slider with the holes in the indicator panel. Install heavy-gauge wire to hold the slider.
3. Temporary install the indicator panel to the selector lever bracket.

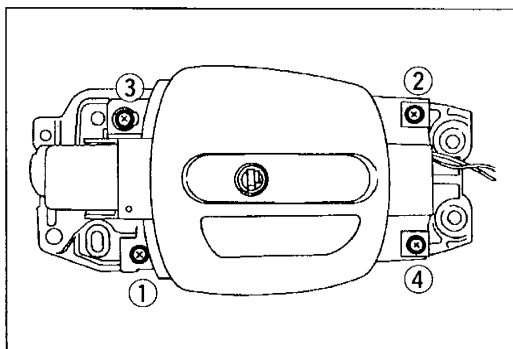

4. Tighten the indicator panel screws in the order shown in the figure.



Tightening torque:

2.0—2.9 N·m { 20—30 kgf·cm , 18—26 in·lbf }

5. Remove the wire.
6. Verify that the selector lever properly aligns with the indicator panel in all ranges and positions.

ON-BOARD DIAGNOSTIC SYSTEM

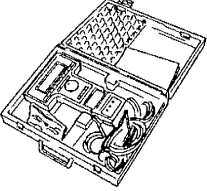
PREPARATION
SST

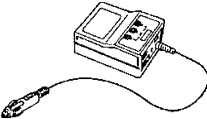
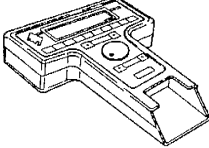
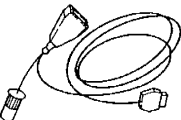
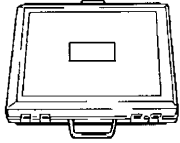
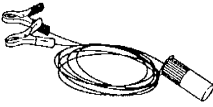
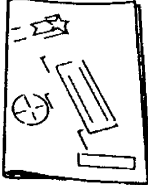
<p>49 T088 0A0 NGS set</p> 	<p>For diagnosis of EC-AT</p>	<p>49 T088 010B Program Card</p> 	<p>For diagnosis of EC-AT</p>
<p>49 T088 002 Vehicle Interface Module (Part of 49 T088 0A0)</p> 	<p>For diagnosis of EC-AT</p>	<p>49 T088 001 Control unit (Part of 49 T088 0A0)</p> 	<p>For diagnosis of EC-AT</p>
<p>49 T088 004 NGS OBDII Adapter (Part of 49 T088 0A0)</p> 	<p>For diagnosis of EC-AT</p>	<p>49 T088 009 Case (Part of 49 T088 0A0)</p> 	<p>For diagnosis of EC-AT</p>
<p>49 T088 006 Battery Hookup Adapter (Part of 49 T088 0A0)</p> 	<p>For diagnosis of EC-AT</p>	<p>49 T088 008 Instruction Manual</p> 	<p>For diagnosis of EC-AT</p>

**DIAGNOSTIC TROUBLE CODE
Inspection Procedure**

1. Connect the **SST** (NGS) to the data link connector 2 and battery.
2. Turn the ignition switch to **ON**.
3. Check the diagnostic trouble code(s).
(Refer to section F1, F2.)
4. If a diagnostic trouble code(s) is displayed, check for the cause by using the number on the diagnostic trouble code table. (Repair as necessary.)
5. Following repairs, do the After-Repair procedure to verify that there are no remaining codes.

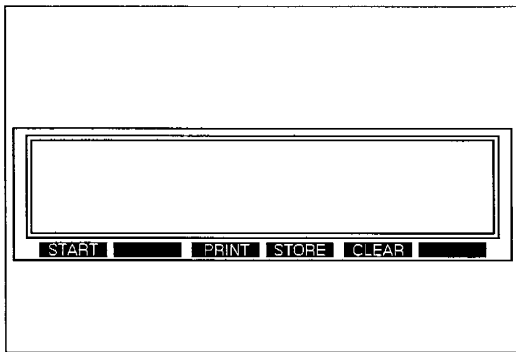
**After-Repair Procedure**

1. Cancel the diagnostic trouble code memory by using the **SST** (NGS). (Refer to section F1, F2.)
2. Remove the **SST** (NGS) from the data link connector 2.

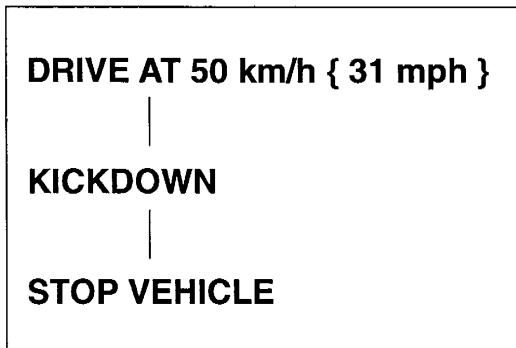

3. Drive the vehicle at 50 km/h { 31 mph }, and depress the accelerator pedal fully to activate kickdown. Stop the vehicle gradually.

4. Connect the **SST** (NGS) to the data link connector 2 and battery.
5. Turn the ignition switch to ON.
6. Verify that no diagnostic trouble codes are displayed. (Refer to section F1, F2.)
7. Remove the **SST** from the data link connector 2.

Troubleshooting

- If a diagnostic trouble code is shown on the **SST**, check for the cause by using the chart related to the code shown.

Diagnostic Trouble Code

Code No.	Display on the NGS	Condition	Page
P0705	TRANS RANGE SENSOR — CKT MALFUNCTION	Transaxle Range Switch	K-62
P0710	TRANS FLUID TEMP SENS — CKT MALFUNCTION	Transaxle Fluid Temperature Sensor	K-63
P0715	INPUT/TSS CIRCUIT MALFUNCTION	Input/Turbine Speed Sensor	K-64
P0731	GEAR 1 INCORRECT RATIO	Gear 1 Incorrect Ratio	K-65
P0732	GEAR 2 INCORRECT RATIO	Gear 2 Incorrect Ratio	K-66
P0733	GEAR 3 INCORRECT RATIO	Gear 3 Incorrect Ratio	K-67
P0734	GEAR 4 INCORRECT RATIO	Gear 4 Incorrect Ratio	K-68
P0740	TORQUE CONV CLUTCH SYS — MALFUNCTION	Torque Converter Clutch System Malfunction	K-69
P0750	SHIFT SOLENOID A — MALFUNCTION	Shift Solenoid A	K-70
P0755	SHIFT SOLENOID B — MALFUNCTION	Shift Solenoid B	K-71
P0760	SHIFT SOLENOID C — MALFUNCTION	Shift Solenoid C	K-72
P1743	SOLENOID TCC — OPEN OR SHORT	Torque converter clutch solenoid valve	K-73

DIAGNOSTIC TROUBLE CODE P0705		TRANS RANGE SENSOR — CKT MALFUNCTION (Transaxle Range Switch)				
DETAILS		No input signal or input of two or more signals from transaxle range switch				
POSSIBLE CAUSE		<ul style="list-style-type: none"> • Transaxle range switch malfunction • Damaged wiring or connectors between transaxle range switch and powertrain control module • Powertrain control module malfunction 				
STEP	INSPECTION	ACTION				
1	Are powertrain control module or transaxle range switch connections at the connector(s) and connector pins OK?	Yes	Go to next step			
		No	Repair or replace connector(s) Inspection step 6 <ul style="list-style-type: none"> • Yes: Go to next step • No: End of flowchart 			
2	Check EC-AT tester display <ul style="list-style-type: none"> • Connect the EC-AT tester to powertrain control module • Are transaxle range switch range and EC-AT tester display correct? ↗ page K-16	Yes	Go to step 6			
				Item	Indication	Condition
					P/N	ON
				OFF		R position, all ranges
				D	ON	D range
					OFF	Other ranges, all positions
		2	ON	2 range		
			OFF	Other ranges, all positions		
		1	ON	1 range		
			OFF	Other ranges, all positions		
3	Check for continuity between terminals of transaxle range switch and powertrain control module <ul style="list-style-type: none"> • Disconnect negative battery cable • Disconnect transaxle range switch and powertrain control module connectors • Is there continuity between the terminals? 	Yes	Go to next step			
		No	Repair or replace connectors and wiring Go to step 2 <ul style="list-style-type: none"> • When Yes, go to step 6 • When No, go to next step 			
4	Check for continuity between terminals of the transaxle range switch as follows <ul style="list-style-type: none"> • Disconnect negative battery cable • Disconnect transaxle range switch connector • Is there continuity between the terminals? 	Yes	Go to next step			
		No	Repair or adjust transaxle range switch ↗ page K-25 Go to step 2 <ul style="list-style-type: none"> • When Yes, go to step 6 • When No, go to next step 			
5	Check for continuity between terminals of transaxle range switch and main relay <ul style="list-style-type: none"> • Disconnect negative battery cable • Disconnect transaxle range switch and main relay • Is there continuity between the terminals? 	Yes	Go to next step			
		No	Repair or replace connectors and wiring			
6	After diagnostic trouble code has been cleared, re-check if diagnostic trouble code is shown ↗ page K-60	Yes	Replace powertrain control module ↗ section F1, F2			
		No	Problem is a temporary poor connection of wiring or connectors, and should be investigated further			

DIAGNOSTIC TROUBLE CODE P0710		TRANS FLUID TEMP SENS — CKT MALFUNCTION (Transaxle Fluid Temperature Sensor)	
DETAILS		Powertrain control module input voltage is less than 0.09 V or over 5.0 V	
POSSIBLE CAUSE		<ul style="list-style-type: none"> • Transaxle fluid temperature sensor malfunction • Damaged wiring or connectors between transaxle fluid temperature sensor and powertrain control module • Powertrain control module malfunction 	
STEP	INSPECTION	ACTION	
1	Are powertrain control module or transaxle fluid temperature sensor connections at the connector(s) and connector pins OK?	Yes	Go to next step
		No	Repair or replace connector(s) Inspection step 5 <ul style="list-style-type: none"> • Yes: Go to next step • No: End of flowchart
2	Check EC-AT tester display <ul style="list-style-type: none"> • Connect EC-AT tester to powertrain control module • Is transaxle fluid temperature sensor voltage correct? Voltage ATF temp. 20 °C { 68 °F } : Approx. 4.0 V 130 °C { 266 °F } : Approx. 1.5 V ⓘ page K-16	Yes	Go to step 5
		No	Go to next step
3	Check for continuity between terminals of transaxle fluid temperature sensor and powertrain control module <ul style="list-style-type: none"> • Disconnect negative battery cable • Disconnect transaxle fluid temperature sensor and powertrain control module connectors • Is there continuity between terminals? 	Yes	Go to next step
		No	Repair or replace connectors and wiring Go to step 2 <ul style="list-style-type: none"> • When Yes, go to step 5 • When No, go to next step
4	Measure resistance between the transaxle fluid temperature sensor terminals <ul style="list-style-type: none"> • Disconnect negative battery cable • Disconnect transaxle fluid temperature sensor connector • Is resistance between terminals correct? Resistance ATF temp. 20 °C { 68 °F } : 21.0—25.0 kΩ 40 °C { 104 °F } : 10.0—12.1 kΩ 80 °C { 176 °F } : 3.0—3.4 kΩ ⓘ page K-27	Yes	Go to next step
		No	Replace transaxle fluid temperature sensor ⓘ page K-27
5	After diagnostic trouble code has been cleared, re-check if diagnostic trouble code is shown ⓘ page K-60	Yes	Replace powertrain control module ⓘ section F1, F2
		No	Problem is a temporary poor connection of wiring or connectors, and should be investigated further

DIAGNOSTIC TROUBLE CODE P0715		INPUT/TSS CIRCUIT MALFUNCTION (Input/Turbine Speed Sensor)	
DETAILS		Signal from input/turbine speed sensor is not input to powertrain control module when vehicle is moving.	
POSSIBLE CAUSE		<ul style="list-style-type: none"> • Input/turbine speed sensor malfunction • Damaged harness or connectors between input/turbine speed sensor and powertrain control module • Powertrain control module malfunction 	
STEP	INSPECTION	ACTION	
1	Are powertrain control module or input/turbine speed sensor connection at the connector(s) and connector pins OK?	Yes	Go to next step
		No	Repair or replace connector(s) Inspection step 5 <ul style="list-style-type: none"> • Yes: Go to next step • No: End of flowchart
2	Check EC-AT tester display <ul style="list-style-type: none"> • Connect EC-AT tester to powertrain control module • Is speed indicated on EC-AT tester after engine is started and vehicle is idling? 🔍 page K-16	Yes	Go to step 5
		No	Go to next step
3	Check for continuity between terminals of input/turbine speed sensor and powertrain control module <ul style="list-style-type: none"> • Disconnect negative battery cable • Disconnect input/turbine speed sensor and powertrain control module connectors • Is there continuity between terminals? 	Yes	Go to next step
		No	Repair or replace connectors and wiring Go to step 2 <ul style="list-style-type: none"> • When Yes, go to step 5 • When No, go to next step
4	Measure resistance between input/turbine speed sensor terminals <ul style="list-style-type: none"> • Disconnect negative battery cable • Disconnect input/turbine speed sensor connector • Is resistance between terminals correct? Resistance: 200—400 Ω 🔍 page K-29	Yes	Go to next step
		No	Replace input/turbine speed sensor 🔍 page K-29
5	After diagnostic trouble code has been cleared, re-check if diagnostic trouble code is shown 🔍 page K-60	Yes	Replace powertrain control module 🔍 section F1, F2
		No	Problem is a temporary poor connection of wiring or connectors, and should be investigated further

DIAGNOSTIC TROUBLE CODE P0731		GEAR 1 INCORRECT RATIO (Gear 1 Incorrect Ratio)	
DETAILS		Powertrain control module output solenoid pattern of first gear when gear ratio is other than first gear	
POSSIBLE CAUSE		<ul style="list-style-type: none"> • ATF level low • Solenoid valve malfunction • Line pressure low • Control valve stuck • Powertrain control module malfunction 	
STEP	INSPECTION	ACTION	
1	Is diagnostic trouble code P0750, P0755, or P0760 indicated? ☞ page K-59	Yes	Refer to flowchart for diagnostic trouble code P0750, P0755, or P0760 and, then troubleshoot ☞ page K-70, 71, 72
		No	Go to next step
2	Are amount and condition (color) of ATF OK? Check for ATF leakage at transaxle connection and gasket Color ① Transparent red: Normal ② Black: Defective part in powertrain ③ Light red: Water mixed in fluid ④ Reddish brown: Deteriorated ATF ☞ page K-10	Yes	Go to next step
		No	Adjust ATF amount or replace ATF if necessary • If ATF color is ②, measure line pressure at idle when pressure is less than specification, go to step 4 • If ATF color is ③ or ④, replace ATF
3	Is turbine speed OK under following conditions? • EC-AT tester connected to powertrain control module • Throttle is 2/8 open, and vehicle speed is 20 km/h { 12 mph } in D range (Except O/D OFF mode) Turbine speed Z5: 2,150 rpm BP: 2,000 rpm ☞ page K-16	Yes	Go to step 8
		No	Above specification: Go to next step Below specification: Go to step 6
4	Check line pressure in D range (Except O/D OFF mode) • Is line pressure OK? Line pressure when in D range (Except O/D OFF mode) Idling: 430—550 kPa { 4.3—5.7 kgf/cm ² , 62—81 psi } Stalled: 920—1,040 kPa { 9.3—10.7 kgf/cm ² , 140—152 psi } ☞ page K-3	Yes	Go to next step
		No	Repair or replace any defective parts • Line pressure is low only when in D or 2 range: ATF leakage in forward clutch circuit ☞ Automatic Transaxle Workshop Manual FA4A-EL
5	Check stall speed in D range (Except O/D OFF mode) • Is stall speed OK? Stall speed when in D range (Except O/D OFF mode) Z5: 1,950—2,250 rpm BP: 2,200—2,500 rpm ☞ page K-5	Yes	Go to next step
		No	Repair or replace any defective parts • High in all range: Shifting of forward clutch, one-way clutch 1 • High in D range: Shifting of one-way clutch 2
6	Inspect operation of shift solenoid A, B, C • Disconnect negative battery cable • Disconnect solenoid connector • Is it operating OK? ☞ page K-30	Yes	Go to next step ☞ Automatic Transaxle Workshop Manual FA4A-EL
		No	Replace shift solenoid A, B, or C ☞ page K-30 Go to step 2 • When Yes, go to step 8 • When No, go to next step
7	Check operation of each valve and inspect return spring • Is each valve operating OK and is return spring OK?	Yes	Go to next step
		No	Repair or replace control valve and replace return spring ☞ Automatic Transaxle Workshop Manual FA4A-EL
8	After diagnostic trouble code has been cleared, re-check if diagnostic trouble code is shown ☞ page K-60	Yes	Replace powertrain control module ☞ section F1, F2
		No	Problem is a temporary slip of clutch, and should be investigated further

DIAGNOSTIC TROUBLE CODE P0732		GEAR 2 INCORRECT RATIO (Gear 2 Incorrect Ratio)	
DETAILS		Powertrain control module output solenoid pattern of second gear when gear ratio is other than second gear	
POSSIBLE CAUSE		<ul style="list-style-type: none"> • ATF level low • Forward clutch slippage • 2-4 brake band slippage • Solenoid valve malfunction 	<ul style="list-style-type: none"> • Line pressure low • One-way clutch 1 slippage • Control valve stuck • Powertrain control module malfunction
STEP	INSPECTION	ACTION	
1	Is diagnostic trouble code P0750, P0755, or P0760 indicated? 📖 page K-59	Yes	Refer to flowchart for diagnostic trouble code P0750, P0755, or P0760 and then troubleshoot 📖 page K-70, 71, 72
		No	Go to next step
2	Are amount and condition (color) of ATF OK? Check for ATF leakage at transaxle connection and gasket Color ① Transparent red: Normal ② Black: Defective part in powertrain ③ Light red: Water mixed in fluid ④ Reddish brown: Deteriorated ATF 📖 page K-10	Yes	Go to next step
		No	Adjust ATF amount or replace ATF if necessary • If ATF color is ②, measure line pressure at idle when pressure is less than specification, go to step 4 • If ATF color is ③ or ④, replace ATF
3	Is turbine speed OK under following conditions? • EC-AT tester connected to powertrain control module • Throttle is 2/8 open, and vehicle speed is 20 km/h { 12 mph } is 2 range Turbine speed Z5: 1,200 rpm BP: 1,100 rpm 📖 page K-16	Yes	Go to step 8
		No	Above specification: Go to next step Below specification: Go to step 6
4	Check line pressure in D, 2 range • Is line pressure OK? Line pressure when in D, 2 range Idling: 430-550 kPa { 4.3-5.7 kgf/cm ² , 62-81 psi } Stalled: 920-1,040 kPa { 9.3-10.7 kgf/cm ² , 140-152 psi } 📖 page K-3	Yes	Go to next step
		No	Repair or replace any defective parts • ATF leakage in 2-4 brake band circuit • ATF leakage in forward clutch circuit 📖 Automatic Transaxle Workshop Manual FA4A-EL
5	Check stall speed in D, 2 range • Is stall speed OK? Stall speed when in D, 2 range Z5: 1,950-2,250 rpm BP: 2,200-2,500 rpm 📖 page K-5	Yes	Go to next step
		No	Repair or replace any defective parts • 2-4 brake band slipping • Forward clutch slipping 📖 Automatic Transaxle Workshop Manual FA4A-EL
6	Inspect operation of shift solenoid A, B, C • Disconnect negative battery cable • Disconnect solenoid connector • Is it operating OK? 📖 page K-30	Yes	Go to next step
		No	Replace shift solenoid A, B, or C 📖 page K-30 Go to step 2 • When Yes, go to step 8 • When No, go to next step
7	Check operation of each valve and inspect return spring • Is each valve operating OK and is return spring OK?	Yes	Go to next step
		No	Repair or replace control valve and replace return spring 📖 Automatic Transaxle Workshop Manual FA4A-EL
8	After diagnostic trouble code has been cleared, re-check if diagnostic trouble code is shown 📖 page K-60	Yes	Replace the powertrain control module 📖 section F1, F2
		No	Problem is a temporary slip of clutch, and should be investigated further

DIAGNOSTIC TROUBLE CODE P0733		GEAR 3 INCORRECT RATIO (Gear 3 Incorrect Ratio)	
DETAILS		Powertrain control module output solenoid pattern of third gear when gear ratio is other than third gear	
POSSIBLE CAUSE		<ul style="list-style-type: none"> • ATF level low • Forward clutch slippage • 3-4 clutch slippage • Solenoid valve malfunction 	<ul style="list-style-type: none"> • Line pressure low • One-way clutch 1 slippage • Control valve stuck • Powertrain control module malfunction
STEP	INSPECTION	ACTION	
1	Is diagnostic trouble code P0750, P0755, or P0760 indicated? 📖 page K-59	Yes	Refer to flowchart for diagnostic trouble code P0750, P0755, or P0760 and then troubleshoot 📖 page K-70, 71, 72
		No	Go to next step
2	Are amount and condition (color) of ATF OK? Check for ATF leakage at transaxle connection and gasket Color ① Transparent red: Normal ② Black: Defective part in powertrain ③ Light red: Water mixed in fluid ④ Reddish brown: Deteriorated ATF 📖 page K-10	Yes	Go to next step
		No	Adjust ATF amount or replace ATF if necessary • If ATF color is ②, measure line pressure at idle when pressure is less than specification, go to step 4. • If ATF color is ③ or ④, replace ATF
3	Is turbine speed OK under following conditions? • Solenoid connector disconnected • EC-AT tester connected to powertrain control module • Throttle is 2/8 open, and vehicle speed is 20 km/h {12 mph} in third gear in D range Turbine speed Z5: 800 rpm BP: 750 rpm 📖 page K-16	Yes	Go to step 8
		No	Above specification: Go to next step Below specification: Go to step 6
4	Check line pressure when solenoid connector is disconnected • Solenoid connector disconnected • Is line pressure OK? Line pressure when third gear in D range Idling: 430-550 kPa { 4.3-5.7 kgf/cm ² , 62-81 psi } Stalled: 920-1,040 kPa { 9.3-10.7 kgf/cm ² , 140-152 psi } 📖 page K-3	Yes	Go to next step
		No	Repair or replace any defective parts • ATF leakage in 3-4 clutch 📖 Automatic Transaxle Workshop Manual FA4A-EL
5	Check stall speed when solenoid connector is disconnected • Solenoid connector disconnected • Is stall speed OK? Stall speed when third gear in D range Z5: 1,950-2,250 rpm BP: 2,200-2,500 rpm 📖 page K-5	Yes	Go to next step
		No	Repair or replace any defective parts • 3-4 clutch slipping 📖 Automatic Transaxle Workshop Manual FA4A-EL
6	Inspect operation of shift solenoid A, B, C • Disconnect negative battery cable • Disconnect solenoid connector • Is it operating OK? 📖 page K-30	Yes	Go to next step
		No	Replace shift solenoid A, B, or C 📖 page K-30 Go to step 2 • When Yes, go to step 8 • When No, go to next step
7	Check operation of each valve and inspect return spring • Is each valve operating OK and is return spring OK?	Yes	Go to next step
		No	Repair or replace control valve and replace return spring 📖 Automatic Transaxle Workshop Manual FA4A-EL
8	After diagnostic trouble code has been cleared, re-check if diagnostic trouble code is shown 📖 page K-60	Yes	Replace powertrain control module 📖 section F1, F2
		No	Problem is a temporary slip of clutch, and should be investigated further

DIAGNOSTIC TROUBLE CODE P0734		GEAR 4 INCORRECT RATIO (Gear 4 Incorrect Ratio)	
DETAILS		Powertrain control module outputs solenoid pattern of fourth gear when gear ratio is other than fourth gear.	
POSSIBLE CAUSE		<ul style="list-style-type: none"> • ATF level low • 2–4 brake band slippage • Control valve stuck • Powertrain control module malfunction 	<ul style="list-style-type: none"> • Line pressure low • 3–4 clutch slippage • Solenoid valve malfunction
STEP	INSPECTION	ACTION	
1	Is diagnostic trouble code P0750, P0755, or P0760 indicated? 📖 page K–59	Yes	Refer to flowchart for diagnostic trouble code P0750, P0755, or P0760, and then troubleshoot 📖 page K–70, 71, 72
		No	Go to next step
2	Are amount and condition (color) of ATF OK? Check for ATF leakage at transaxle connection and gasket Color ① Transparent red: Normal ② Black: Defective part in powertrain ③ Light red: Water mixed in fluid ④ Reddish brown: Deteriorated ATF 📖 page K–10	Yes	Go to next step
		No	Adjust ATF amount or replace ATF if necessary • If ATF color is ②, measure line pressure at idle when pressure is less than specification, repair or replace any defective parts • If ATF color is ③ or ④, replace ATF
3	Is diagnostic trouble code P0732 (Gear 2 incorrect ratio) indicated? 📖 page K–59	Yes	Refer to flowchart for diagnostic trouble code P0732 (Gear 2 incorrect ratio), and then troubleshoot 📖 page K–66
		No	Go to next step
4	Is diagnostic trouble code P0733 (Gear 3 incorrect ratio) indicated? 📖 page K–59	Yes	Refer to flowchart for diagnostic trouble code P0733 (Gear 3 incorrect ratio), and then troubleshoot 📖 page K–67
		No	Go to next step
5	Inspect operation of shift solenoid A, B, C • Disconnect negative battery cable • Disconnect solenoid connector • Is it operating OK? 📖 page K–30	Yes	Go to next step
		No	Replace shift solenoid A, B, or C 📖 page K–30 Inspection step 7 • Yes: Go to next step • No: End of flowchart
6	Check operation of each valve and inspect return spring • Is each valve operating OK and is return spring OK?	Yes	Go to next step
		No	Repair or replace control valve and replace return spring 📖 Automatic Transaxle Workshop Manual FA4A-EL
7	After diagnostic trouble code has been cleared, re-check if diagnostic trouble code is shown 📖 page K–60	Yes	Replace powertrain control module 📖 section F1, F2
		No	Problem is a temporary slip of clutch, and should be investigated further

DIAGNOSTIC TROUBLE CODE P0740		TORQUE CONV CLUTCH SYS — MALFUNCTION (Torque Converter Clutch System Malfunction)	
DETAILS	Signal output by powertrain control module for torque converter clutch operation, but no torque converter clutch obtained		
POSSIBLE CAUSE	<ul style="list-style-type: none"> • ATF level low • Torque converter clutch slippage • Torque converter clutch solenoid valve malfunction 	<ul style="list-style-type: none"> • Powertrain control module malfunction • Line pressure low • Control valve stuck 	
STEP	INSPECTION		ACTION
1	Are amount and condition (color) of ATF OK? Check for ATF leakage at transaxle connection and gasket Color ① Transparent red: Normal ② Black: Defective part in powertrain ③ Light red: Water mixed in fluid ④ Reddish brown: Deteriorated ATF 📖 page K-10	Yes	Go to next step
		No	Adjust ATF amount or replace ATF if necessary • If ATF color is ②, disassemble transaxle and repair or replace any defective parts as necessary • If ATF color is ③ or ④, replace ATF
2	Check line pressure in D range (Except O/D OFF mode) • Is line pressure OK? Line pressure when in D range (Except O/D OFF mode) Idling: 430—550 kPa { 4.3—5.7 kgf/cm ² , 62—81 psi } Stalled: 920—1,040 kPa { 9.3—10.7 kgf/cm ² , 140—152 psi } 📖 page K-3	Yes	Go to next step
		No	Repair or replace any defective parts • ATF leakage in transaxle case, oil pump, control valve 📖 Automatic Transaxle Workshop Manual FA4A-EL
3	Inspect operation of solenoid valve • Disconnect negative battery cable • Disconnect solenoid connector • Is it operating OK? 📖 page K-30	Yes	Go to next step
		No	Replace torque converter clutch solenoid valve 📖 page K-30
4	Check operation of each valve and inspect return spring • Is each valve operating OK and is return spring OK?	Yes	Go to next step
		No	Repair or replace control valve and replace return spring 📖 Automatic Transaxle Workshop Manual FA4A-EL
5	Check difference between engine speed and turbine speed during torque converter clutch operation in fourth gear • Connect EC-AT tester to powertrain control module • Check difference between engine speed and turbine speed during torque converter clutch operation in fourth gear Is there a difference between engine speed and turbine speed? 📖 page K-16	Yes	Replace torque converter 📖 Automatic Transaxle Workshop Manual FA4A-EL
		No	Go to next step
6	After diagnostic trouble code has been cleared, re-check if diagnostic trouble code is shown 📖 page K-60	Yes	Replace powertrain control module 📖 section F1, F2
		No	Problem is a temporary slip of clutch, and should be investigated further

DIAGNOSTIC TROUBLE CODE P0750		SHIFT SOLENOID A—MALFUNCTION (Shift Solenoid A)	
DETAILS	<ul style="list-style-type: none"> • Damaged wiring or connectors between shift solenoid A and powertrain control module • Short or open circuit in shift solenoid A • Short or open circuit in powertrain control module internal transistor 		
POSSIBLE CAUSE	<ul style="list-style-type: none"> • Damaged wiring or connectors between shift solenoid A and powertrain control module • Short or open circuit in shift solenoid A • Short or open circuit in powertrain control module internal transistor 		
STEP	INSPECTION		ACTION
1	Are powertrain control module or shift solenoid A connections at connector(s) and connector pins OK?	Yes	Go to next step
		No	Repair or replace connector(s) Inspection step 5 • Yes: Go to next step • No: End of flowchart
2	Check EC-AT tester display <ul style="list-style-type: none"> • Connect EC-AT tester to powertrain control module • Is light for shift solenoid A normally off and illuminated when valve is on? ⓘ page K-16	Yes	Go to step 5
		No	Go to next step
3	Check for continuity between terminals of shift solenoid A and powertrain control module <ul style="list-style-type: none"> • Disconnect negative battery cable • Disconnect solenoid connector and powertrain control module connector • Is there continuity between terminals? 	Yes	Go to next step
		No	Repair or replace connectors and wiring Go to step 2 • When Yes , go to step 5 • When No , go to next step
4	Measure resistance at shift solenoid A terminal <ul style="list-style-type: none"> • Disconnect negative battery cable • Disconnect solenoid connector • Is resistance correct? Resistance: 13—27 Ω ⓘ page K-30	Yes	Go to next step
		No	Replace shift solenoid A ⓘ page K-30
5	After diagnostic trouble code has been cleared, re-check if diagnostic trouble code is shown ⓘ page K-60	Yes	Replace powertrain control module ⓘ section F1, F2
		No	Problem is a temporary poor connection of wiring or connectors, and should be investigated further

DIAGNOSTIC TROUBLE CODE P0755		SHIFT SOLENOID B—MALFUNCTION (Shift Solenoid B)	
DETAILS	<ul style="list-style-type: none"> • Damaged wiring or connectors between shift solenoid B and powertrain control module • Short or open circuit in shift solenoid B • Short or open circuit in powertrain control module internal transistors 		
POSSIBLE CAUSE	<ul style="list-style-type: none"> • Damaged wiring or connectors between shift solenoid B and powertrain control module • Short or open circuit in shift solenoid B • Short or open circuit in powertrain control module internal transistors 		
STEP	INSPECTION		ACTION
1	Are powertrain control module or shift solenoid B connections at connector(s) and connector pins OK?	Yes	Go to next step
		No	Repair or replace connector(s) Inspection step 5 • Yes: Go to next step • No: End of flowchart
2	Check EC-AT tester display • Connect EC-AT tester to powertrain control module • Is light for shift solenoid B normally off and illuminated when valve is on? ⓘ page K-16	Yes	Go to step 5
		No	Go to next step
3	Check for continuity between terminals of shift solenoid B and powertrain control module • Disconnect negative battery cable • Disconnect solenoid connector and powertrain control module connector • Is there continuity between terminals?	Yes	Go to next step
		No	Repair or replace connectors and wiring Go to step 2 • When Yes, go to step 5 • When No, go to next step
4	Measure resistance at shift solenoid B terminal • Disconnect negative battery cable • Disconnect solenoid connector • Is resistance correct? Resistance: 13—27 Ω ⓘ page K-30	Yes	Go to next step
		No	Replace shift solenoid B ⓘ page K-30
5	After diagnostic trouble code has been cleared, re-check if diagnostic trouble code is shown ⓘ page K-60	Yes	Replace powertrain control module ⓘ section F1, F2
		No	Problem is a temporary poor connection of wiring or connectors, and should be investigated further

DIAGNOSTIC TROUBLE CODE P0760		SHIFT SOLENOID C—MALFUNCTION (Shift Solenoid C)	
DETAILS	<ul style="list-style-type: none"> • Damaged wiring or connectors between shift solenoid C and powertrain control module • Short or open circuit in shift solenoid C • Short or open circuit in powertrain control module internal transistor 		
POSSIBLE CAUSE	<ul style="list-style-type: none"> • Damaged wiring or connectors between shift solenoid C and powertrain control module • Short or open circuit in shift solenoid C • Short or open circuit in powertrain control module internal transistor 		
STEP	INSPECTION		ACTION
1	Are powertrain control module or shift solenoid C connections at connector(s) and connector pins OK?	Yes	Go to next step
		No	Repair or replace connector(s) Inspection step 5 <ul style="list-style-type: none"> • Yes: Go to next step • No: End of flowchart
2	Check EC-AT tester display <ul style="list-style-type: none"> • Connect EC-AT tester to powertrain control module • Is light for shift solenoid C normally off and illuminated when valve is on? ⓘ page K-16	Yes	Go to step 5
		No	Go to next step
3	Check for continuity between terminals of shift solenoid C and powertrain control module <ul style="list-style-type: none"> • Disconnect negative battery cable • Disconnect solenoid connector and powertrain control module connector • Is there continuity between terminals? 	Yes	Go to next step
		No	Repair or replace connectors and wiring Go to step 2 <ul style="list-style-type: none"> • When Yes, go to step 5 • When No, go to next step
4	Measure resistance at shift solenoid C terminal <ul style="list-style-type: none"> • Disconnect negative battery cable • Disconnect solenoid connector • Is resistance correct? Resistance: 13—27 Ω ⓘ page K-30	Yes	Go to next step
		No	Replace shift solenoid C ⓘ page K-30
5	After diagnostic trouble code has been cleared, re-check if diagnostic trouble code is shown ⓘ page K-60	Yes	Replace powertrain control module ⓘ section F1, F2
		No	Problem is a temporary poor connection of wiring or connectors, and should be investigated further

DIAGNOSTIC TROUBLE CODE P1743		SOLENOID TCC—OPEN OR SHORT (Torque converter clutch solenoid valve)	
DETAILS		<ul style="list-style-type: none"> • Damaged wiring or connectors between torque converter clutch solenoid valve and powertrain control module • Short or open circuit in torque converter clutch solenoid valve • Short or open circuit in powertrain control module internal transistors 	
POSSIBLE CAUSE		<ul style="list-style-type: none"> • Damaged wiring or connectors between torque converter clutch solenoid valve and powertrain control module • Short or open circuit in torque converter clutch solenoid valve • Short or open circuit in powertrain control module internal transistor 	
STEP	INSPECTION		ACTION
1	Are transaxle control module or torque converter clutch solenoid valve connections at connector(s) and connector pins OK?	Yes	Go to next step
		No	Repair or replace connector(s) Inspection step 5 • Yes: Go to next step • No: End of flowchart
2	Check EC-AT tester display • Connect EC-AT tester to powertrain control module • Is light for torque converter clutch solenoid valve normally off and illuminated when valve is on? ☞ page K-16	Yes	Go to step 5
		No	Go to next step
3	Check for continuity between terminals of torque converter clutch solenoid valve and powertrain control module • Disconnect negative battery cable • Disconnect solenoid connector and powertrain control module connector • Is there continuity between terminals?	Yes	Go to next step
		No	Repair or replace connectors and wiring Go to step 2 • When Yes, go to step 5 • When No, go to next step
4	Measure resistance at torque converter clutch solenoid valve terminal • Disconnect negative battery cable • Disconnect solenoid connector • Is resistance correct? Resistance: 13—27 Ω ☞ page K-30	Yes	Go to next step
		No	Replace torque converter clutch solenoid valve ☞ page K-30
5	After diagnostic trouble code has been cleared, re-check if diagnostic trouble code is shown ☞ page K-60	Yes	Replace powertrain control module ☞ section F1, F2
		No	Problem is a temporary poor connection of wiring or connectors, and should be investigated further

TROUBLESHOOTING

TROUBLESHOOTING NOTES

Work Flow

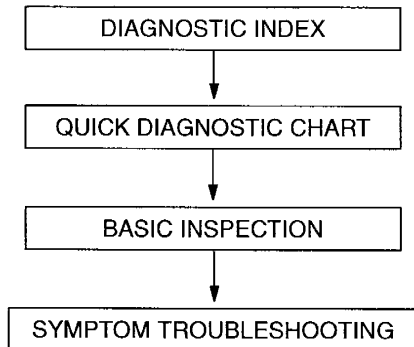

- Choose the item that most closely corresponds to the actual symptom. (Refer to page K-77.)
- Estimate possible causes and verify which is effective for diagnosis in the mechanical system test. (Refer to page K-78.)
- Quickly decide the cause of the problem and check the part which might be the symptom. (Refer to page K-82.)
- Determine the cause of the trouble by using the “DIAGNOSTIC INDEX”. (Refer to page K-83.)

Usage

Diagnostic index

- The diagnostic index describes each troubleshooting item which is shown in the “SYMPTOM TROUBLESHOOTING CHART”.
- This helps with symptom troubleshooting.

TROUBLESHOOTING ITEM		DESCRIPTION	PAGE
No.	TROUBLE		
1	Vehicle does not move	Vehicle does not move when accelerator pedal depressed after being shifted to D, 2, 1 ranges and/or R position. Engine speed increases.	K-83
2	Poor acceleration	Vehicle speed slowly increases during acceleration. Engine speed increases but the torque is not transmitted to the driving wheels.	K-86
3	Shifting not possible	Single range shift (1-2, 2-3, or 3-4) only. Slip occurs inside the transaxle and engine speed increases.	K-87
4	Shift point high or low	Shift points do not match shift diagram. Shift occurs frequently.	K-92
5	Excessive shift shock	Strong shift shock felt when shifted while cruising.	K-93
6	Excessive select shock	Strong shift shock felt at idle when shifted to each range.	K-97
7	Engine speed flares up	Engine flares up temporarily while cruising or when shifted.	K-101
8	Torque converter clutch operation not possible	Torque converter clutch does not operation when vehicle speed reaches torque converter clutch range.	K-105
9	Engine stalls on deceleration	Strong shift shock on deceleration. Engine stops at the end of deceleration.	K-106
10	No engine braking	Engine speed drops to idle but vehicle does not slow down when accelerator pedal released during cruising at medium to high speed.	K-107
11	Engine starts in all ranges and R position	—	K-108
12	Vehicle moves in P or N position	—	K-108
13	Engine does not start	Starter does not work.	section

Quick diagnosis chart

- It helps you to quickly determine the relationship between the symptom and its cause in conjunction with other problems which may occur at the same time.
- The "Inspection method" section helps you to choose the most effective way to deal with the problem.

PART WHICH MAY BE THE SYMPTOM		PARTS WHICH MAY BE THE CAUSE OF PROBLEMS																																																																														
1	Vehicle does not move																																																																															
2	Poor acceleration																																																																															
3	Shift not possible																																																																															
4	Shift point high or low																																																																															
5	Excessive shift shock																																																																															
6	Excessive select shock																																																																															
7	Engine speed flares up																																																																															
8	Torque converter clutch operation not possible																																																																															
9	Engine stalls																																																																															
10	No engine braking																																																																															
11	Engine starts in all ranges and R position																																																																															
12	Vehicle moves in P or N position																																																																															
13	Engine does not start																																																																															
No.	Item	Electrical system components																																																																														
Symptom		ATX outer parts									ATX inner parts																																																																					
		Selector lever			Throttle cable			Transaxle range switch			Throttle position sensor			Input/turbine speed sensor			Vehicle speedometer sensor			Brake switch			O/D OFF switch			Engine coolant temperature sensor			Transaxle fluid temperature sensor																																																			
Inspection method		Cause of trouble																																																																														
		Selector lever misadjusted			Selector cable misadjusted			Throttle cable misadjusted			P, N position signal is not input			D, S, L ranges and R position signal is not input			Misadjusted			VTA signal is not input			Misadjusted			Throttle position sensor malfunction			Signal is not input			Input/turbine speed sensor malfunction			Poor ground			Signal is not input			Vehicle speedometer sensor malfunction			Signal is not input			Brake switch malfunction			Signal is not input			O/D OFF switch malfunction			Signal is not input			Engine coolant temperature sensor malfunction			Signal is not input			Transaxle fluid temperature sensor malfunction			Transaxle fluid temperature sensor malfunction			Shift solenoid A (Open or short)			Shift solenoid B (Open or short)			Shift solenoid C (Open or short)			Torque converter clutch solenoid valve (Open or short)
Item	Result																																																																															
Stall test	Above specification in all ranges and R position																																																																															
	Above specification in D range																																																																															
	Above specification in 2 range																																																																															
Time lag test	Above specification in R position	Engine braking felt in 1 range																																																																														
	Below specification in R position	Engine braking not felt in 1 range																																																																														
	Below specification in all ranges and R position																																																																															
	N→D select	Above specification																																																																														
Line pressure test	Below specification in all ranges and R positions																																																																															
	Below specification in D, 2, and 1 ranges																																																																															
	Below specification in 1 range and R position																																																																															
Diagnostic trouble code	Below specification in R position																																																																															
	Below specification in 2 range																																																																															
	Below specification when solenoid connector is disconnected																																																																															
	Above specification in all ranges and R position																																																																															
	O/D OFF indicator light flashes																																																																															

① CHOOSE THE ACTUAL SYMPTOM

③ DETERMINE THE CAUSE OF THE TROUBLE DETERMINED AT PROCEDURE ②, BASED ON THE RESULT OF THE MECHANICAL SYSTEM TEST

THE PART CAUSING TROUBLE, AS DETERMINED FROM THE RESULT OF THE MECHANICAL SYSTEM TEST.

Basic inspection

- Basic inspection helps you to quickly and easily decide the cause of the problem. It also helpful to inspect the trouble part which might cause many symptoms.

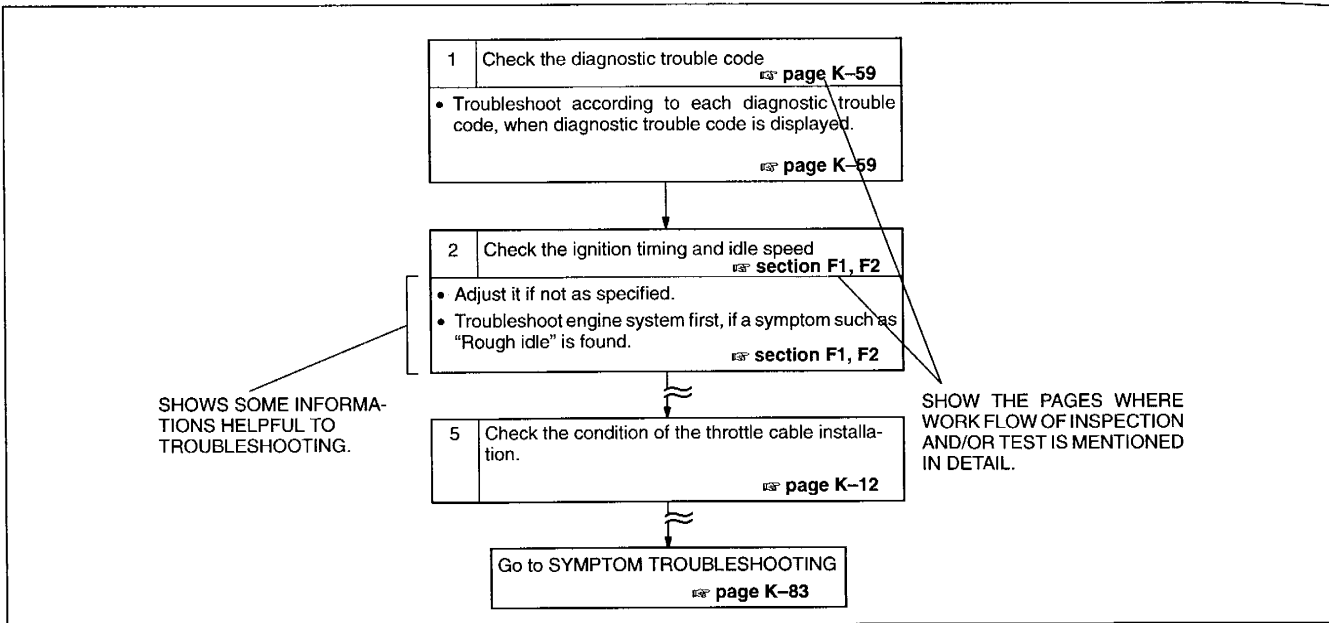

Symptom troubleshooting chart

- This shows the necessary procedures to follow in the form of a flow chart.
- This chart helps you to quickly and accurately pinpoint the problem after determining the symptom.

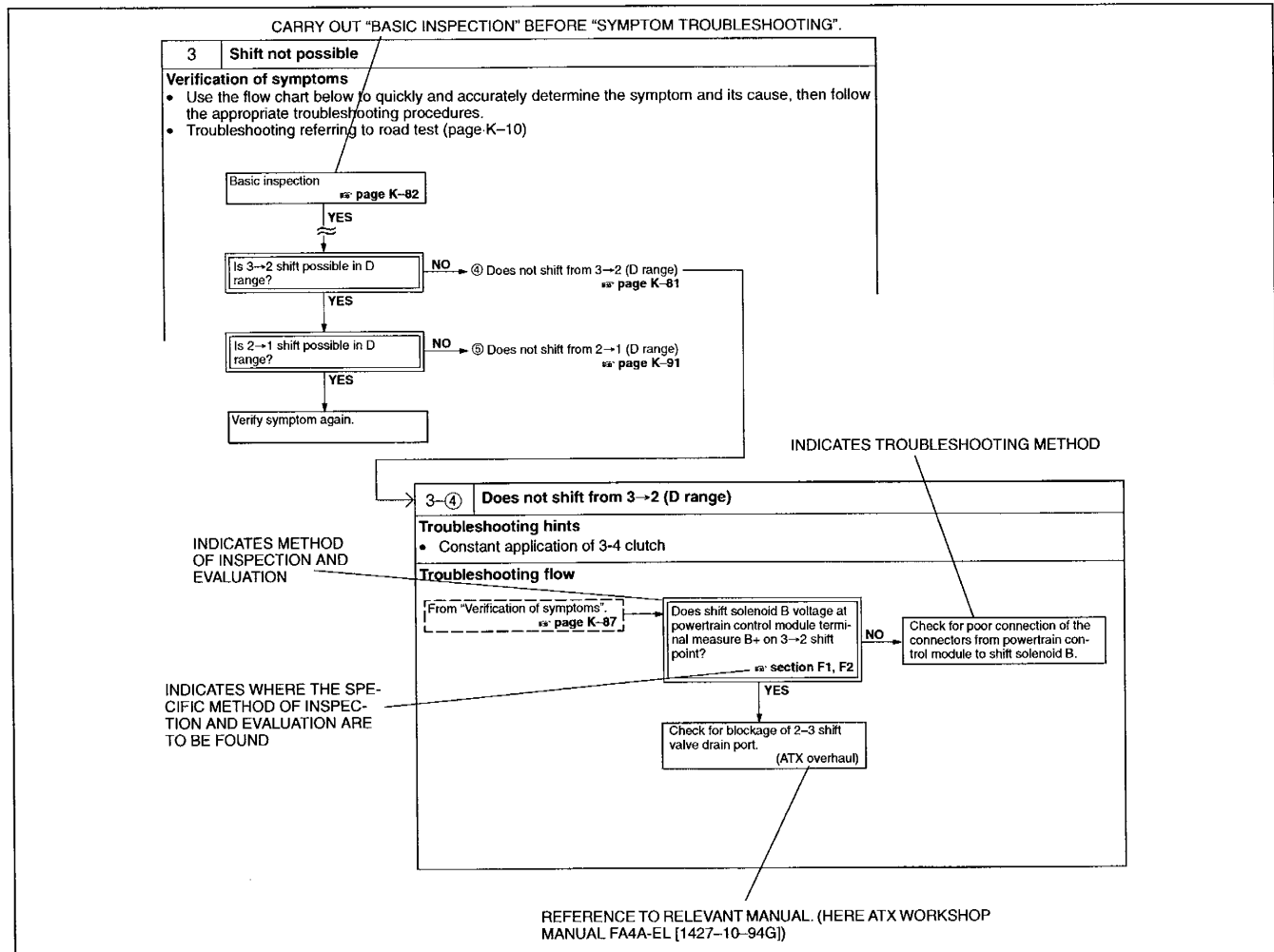

DIAGNOSTIC INDEX

TROUBLESHOOTING ITEM		DESCRIPTION	PAGE
No.	TROUBLE		
1	Vehicle does not move	Vehicle does not move when accelerator pedal depressed after being shifted to D, 2, 1 ranges and/or R position. Engine speed increases.	K-83
2	Poor acceleration	Vehicle speed slowly increases during acceleration. Engine speed increases but the torque is not transmitted to the driving wheels.	K-86
3	Shifting not possible	Single range shift (1-2, 2-3, or 3-4) only. Slip occurs inside the transaxle and engine speed increases.	K-87
4	Shift point high or low	Shift points do not match shift diagram. Shift occurs frequently.	K-92
5	Excessive shift shock	Strong shift shock felt when shifted while cruising.	K-93
6	Excessive select shock	Strong shift shock felt at idle when shifted to each range.	K-97
7	Engine speed flares up	Engine flares up temporarily while cruising or when shifted.	K-101
8	Torque converter clutch operation not possible	Torque converter clutch does not operation when vehicle speed reaches torque converter clutch range.	K-105
9	Engine stalls on deceleration	Strong shift shock on deceleration. Engine stops at the end of deceleration.	K-106
10	No engine braking	Engine speed drops to idle but vehicle does not slow down when accelerator pedal released during cruising at medium to high speed.	K-107
11	Engine starts in all ranges and R position	—	K-108
12	Vehicle moves in P or N position	—	K-108
13	Engine does not start	Starter does not work.	section F1, F2
14	NGS display "LINK COMMUNICATION ERROR"	—	section F1, F2

													Vehicle does not move	1	
													Poor acceleration	2	
													Shifting not possible	3	
													Shift point high or low	4	
													Excessive shift shock	5	
													Excessive select shock	6	
													Engine speed flares up	7	
													Torque converter clutch operation not possible	8	
													Engine stalls	9	
													No engine braking	10	
													Engine starts in all ranges and R position	11	
													Vehicle moves in P or N position	12	
													Engine does not start	13	
Hydraulic system components													Item	No.	
													Symptom		
													Cause of trouble		
													Inspection method		
													Result		
													Item		
													Stall test		
													Time lag test		
													Line pressure test		
<input type="checkbox"/>	<input type="checkbox"/>	<input type="checkbox"/>	<input type="checkbox"/>	<input type="checkbox"/>	<input type="checkbox"/>	<input type="checkbox"/>	<input type="checkbox"/>	<input type="checkbox"/>	<input type="checkbox"/>	<input type="checkbox"/>	<input type="checkbox"/>	<input type="checkbox"/>	Oil pump malfunction	Above specification in all ranges and R position	
<input type="checkbox"/>	<input type="checkbox"/>	<input type="checkbox"/>	<input type="checkbox"/>	<input type="checkbox"/>	<input type="checkbox"/>	<input type="checkbox"/>	<input type="checkbox"/>	<input type="checkbox"/>	<input type="checkbox"/>	<input type="checkbox"/>	<input type="checkbox"/>	<input type="checkbox"/>	Stopped up	Above specification in D range	
<input type="checkbox"/>	<input type="checkbox"/>	<input type="checkbox"/>	<input type="checkbox"/>	<input type="checkbox"/>	<input type="checkbox"/>	<input type="checkbox"/>	<input type="checkbox"/>	<input type="checkbox"/>	<input type="checkbox"/>	<input type="checkbox"/>	<input type="checkbox"/>	<input type="checkbox"/>	ATF leakage	Above specification in 2 range	Above specification in R position
<input type="checkbox"/>	<input type="checkbox"/>	<input type="checkbox"/>	<input type="checkbox"/>	<input type="checkbox"/>	<input type="checkbox"/>	<input type="checkbox"/>	<input type="checkbox"/>	<input type="checkbox"/>	<input type="checkbox"/>	<input type="checkbox"/>	<input type="checkbox"/>	<input type="checkbox"/>	Stopped up	Engine braking felt in 1 range	
<input type="checkbox"/>	<input type="checkbox"/>	<input type="checkbox"/>	<input type="checkbox"/>	<input type="checkbox"/>	<input type="checkbox"/>	<input type="checkbox"/>	<input type="checkbox"/>	<input type="checkbox"/>	<input type="checkbox"/>	<input type="checkbox"/>	<input type="checkbox"/>	<input type="checkbox"/>	ATF leakage	Engine braking not felt in 1 range	Below specification in all ranges and R position
<input type="checkbox"/>	<input type="checkbox"/>	<input type="checkbox"/>	<input type="checkbox"/>	<input type="checkbox"/>	<input type="checkbox"/>	<input type="checkbox"/>	<input type="checkbox"/>	<input type="checkbox"/>	<input type="checkbox"/>	<input type="checkbox"/>	<input type="checkbox"/>	<input type="checkbox"/>	Stopped up	Above specification	
<input type="checkbox"/>	<input type="checkbox"/>	<input type="checkbox"/>	<input type="checkbox"/>	<input type="checkbox"/>	<input type="checkbox"/>	<input type="checkbox"/>	<input type="checkbox"/>	<input type="checkbox"/>	<input type="checkbox"/>	<input type="checkbox"/>	<input type="checkbox"/>	<input type="checkbox"/>	ATF leakage	Below specification	N→D select
<input type="checkbox"/>	<input type="checkbox"/>	<input type="checkbox"/>	<input type="checkbox"/>	<input type="checkbox"/>	<input type="checkbox"/>	<input type="checkbox"/>	<input type="checkbox"/>	<input type="checkbox"/>	<input type="checkbox"/>	<input type="checkbox"/>	<input type="checkbox"/>	<input type="checkbox"/>	2-4 brake band apply pressure	Above specification	N→2 select
<input type="checkbox"/>	<input type="checkbox"/>	<input type="checkbox"/>	<input type="checkbox"/>	<input type="checkbox"/>	<input type="checkbox"/>	<input type="checkbox"/>	<input type="checkbox"/>	<input type="checkbox"/>	<input type="checkbox"/>	<input type="checkbox"/>	<input type="checkbox"/>	<input type="checkbox"/>	ATF leakage	Below specification	N→R select
<input type="checkbox"/>	<input type="checkbox"/>	<input type="checkbox"/>	<input type="checkbox"/>	<input type="checkbox"/>	<input type="checkbox"/>	<input type="checkbox"/>	<input type="checkbox"/>	<input type="checkbox"/>	<input type="checkbox"/>	<input type="checkbox"/>	<input type="checkbox"/>	<input type="checkbox"/>	2-4 brake band release pressure stopped up	Above specification	Below specification in all ranges and R position
<input type="checkbox"/>	<input type="checkbox"/>	<input type="checkbox"/>	<input type="checkbox"/>	<input type="checkbox"/>	<input type="checkbox"/>	<input type="checkbox"/>	<input type="checkbox"/>	<input type="checkbox"/>	<input type="checkbox"/>	<input type="checkbox"/>	<input type="checkbox"/>	<input type="checkbox"/>	Stopped up	Below specification in D, 2, and 1 ranges	
<input type="checkbox"/>	<input type="checkbox"/>	<input type="checkbox"/>	<input type="checkbox"/>	<input type="checkbox"/>	<input type="checkbox"/>	<input type="checkbox"/>	<input type="checkbox"/>	<input type="checkbox"/>	<input type="checkbox"/>	<input type="checkbox"/>	<input type="checkbox"/>	<input type="checkbox"/>	ATF leakage	Below specification in 1 range and R position	Below specification in R position
<input type="checkbox"/>	<input type="checkbox"/>	<input type="checkbox"/>	<input type="checkbox"/>	<input type="checkbox"/>	<input type="checkbox"/>	<input type="checkbox"/>	<input type="checkbox"/>	<input type="checkbox"/>	<input type="checkbox"/>	<input type="checkbox"/>	<input type="checkbox"/>	<input type="checkbox"/>	Stopped up	Below specification in 2 range	
<input type="checkbox"/>	<input type="checkbox"/>	<input type="checkbox"/>	<input type="checkbox"/>	<input type="checkbox"/>	<input type="checkbox"/>	<input type="checkbox"/>	<input type="checkbox"/>	<input type="checkbox"/>	<input type="checkbox"/>	<input type="checkbox"/>	<input type="checkbox"/>	<input type="checkbox"/>	ATF leakage	Below specification when solenoid connector is disconnected	Above specification in all ranges and R position
<input type="checkbox"/>	<input type="checkbox"/>	<input type="checkbox"/>	<input type="checkbox"/>	<input type="checkbox"/>	<input type="checkbox"/>	<input type="checkbox"/>	<input type="checkbox"/>	<input type="checkbox"/>	<input type="checkbox"/>	<input type="checkbox"/>	<input type="checkbox"/>	<input type="checkbox"/>	Hydraulic circuit of torque converter from ATF leakage	O/D OFF indicator light flashes	
<input type="checkbox"/>	<input type="checkbox"/>	<input type="checkbox"/>	<input type="checkbox"/>	<input type="checkbox"/>	<input type="checkbox"/>	<input type="checkbox"/>	<input type="checkbox"/>	<input type="checkbox"/>	<input type="checkbox"/>	<input type="checkbox"/>	<input type="checkbox"/>	<input type="checkbox"/>	Sticking	Diagnostic trouble code	
<input type="checkbox"/>	<input type="checkbox"/>	<input type="checkbox"/>	<input type="checkbox"/>	<input type="checkbox"/>	<input type="checkbox"/>	<input type="checkbox"/>	<input type="checkbox"/>	<input type="checkbox"/>	<input type="checkbox"/>	<input type="checkbox"/>	<input type="checkbox"/>	<input type="checkbox"/>	No application to manual plate		
<input type="checkbox"/>	<input type="checkbox"/>	<input type="checkbox"/>	<input type="checkbox"/>	<input type="checkbox"/>	<input type="checkbox"/>	<input type="checkbox"/>	<input type="checkbox"/>	<input type="checkbox"/>	<input type="checkbox"/>	<input type="checkbox"/>	<input type="checkbox"/>	<input type="checkbox"/>	Throttle valve sticking		
<input type="checkbox"/>	<input type="checkbox"/>	<input type="checkbox"/>	<input type="checkbox"/>	<input type="checkbox"/>	<input type="checkbox"/>	<input type="checkbox"/>	<input type="checkbox"/>	<input type="checkbox"/>	<input type="checkbox"/>	<input type="checkbox"/>	<input type="checkbox"/>	<input type="checkbox"/>	Throttle modulator valve sticking		
<input type="checkbox"/>	<input type="checkbox"/>	<input type="checkbox"/>	<input type="checkbox"/>	<input type="checkbox"/>	<input type="checkbox"/>	<input type="checkbox"/>	<input type="checkbox"/>	<input type="checkbox"/>	<input type="checkbox"/>	<input type="checkbox"/>	<input type="checkbox"/>	<input type="checkbox"/>	Pressure regulator valve sticking		
<input type="checkbox"/>	<input type="checkbox"/>	<input type="checkbox"/>	<input type="checkbox"/>	<input type="checkbox"/>	<input type="checkbox"/>	<input type="checkbox"/>	<input type="checkbox"/>	<input type="checkbox"/>	<input type="checkbox"/>	<input type="checkbox"/>	<input type="checkbox"/>	<input type="checkbox"/>	Spring malfunction		
<input type="checkbox"/>	<input type="checkbox"/>	<input type="checkbox"/>	<input type="checkbox"/>	<input type="checkbox"/>	<input type="checkbox"/>	<input type="checkbox"/>	<input type="checkbox"/>	<input type="checkbox"/>	<input type="checkbox"/>	<input type="checkbox"/>	<input type="checkbox"/>	<input type="checkbox"/>	Sticking		
<input type="checkbox"/>	<input type="checkbox"/>	<input type="checkbox"/>	<input type="checkbox"/>	<input type="checkbox"/>	<input type="checkbox"/>	<input type="checkbox"/>	<input type="checkbox"/>	<input type="checkbox"/>	<input type="checkbox"/>	<input type="checkbox"/>	<input type="checkbox"/>	<input type="checkbox"/>	Sticking		
<input type="checkbox"/>	<input type="checkbox"/>	<input type="checkbox"/>	<input type="checkbox"/>	<input type="checkbox"/>	<input type="checkbox"/>	<input type="checkbox"/>	<input type="checkbox"/>	<input type="checkbox"/>	<input type="checkbox"/>	<input type="checkbox"/>	<input type="checkbox"/>	<input type="checkbox"/>	Draining blocked		
<input type="checkbox"/>	<input type="checkbox"/>	<input type="checkbox"/>	<input type="checkbox"/>	<input type="checkbox"/>	<input type="checkbox"/>	<input type="checkbox"/>	<input type="checkbox"/>	<input type="checkbox"/>	<input type="checkbox"/>	<input type="checkbox"/>	<input type="checkbox"/>	<input type="checkbox"/>	Draining blocked		

1	Vehicle does not move																													
2	Poor acceleration																													
3	Shifting not possible																													
4	Shift point high or low																													
5	Excessive shift shock																													
6	Excessive select shock																													
7	Engine speed flares up																													
8	Torque converter clutch operation not possible																													
9	Engine stalls																													
10	No engine braking																													
11	Engine starts in all ranges and R position																													
12	Vehicle moves in P or N positions																													
13	Engine does not start																													
No.	Item	Hydraulic system components										Powertrain system																		
	Symptom	Control valve body					Converter housing					Torque converter		Forward clutch		Coasting clutch		Reverse clutch												
		3-4 shift valve																												
	Inspection method	Sticking	Draining port is blocked up	Bypass valve not operating properly	3-2 timing valve not operating properly	Low reducing valve sticking	Torque converter clutch control valve sticking	Shift solenoid A sticking	Shift solenoid B sticking	Shift solenoid C sticking	Torque converter clutch solenoid valve sticking	1-2 accumulator not operating properly	2-3 accumulator not operating properly	N-D accumulator not operating properly	N-R accumulator not operating properly	Torque converter clutch piston worn	Burnt	Worn, defaced	Spring malfunction	Dished plate malfunction	Worn, defaced	Spring malfunction	Dished plate malfunction	Worn, defaced	Spring malfunction	Dished plate malfunction				
		Item	Result																											
	Stall test	Above specification in all ranges and R position																												
		Above specification in D range																												
		Above specification in 2 range																												
	Above specification in R position	Engine braking felt in 1 range																												
		Engine braking not felt in 1 range																												
	Below specification in all ranges and R position																													
	Time lag test	N→D select		Above specification																										
		Below specification																												
		N→2 select		Above specification																										
	Below specification																													
	N→R select	Above specification																												
		Below specification																												
	Line pressure test	Below specification in all ranges and R position																												
		Below specification in D, 2, and 1 ranges																												
		Below specification in 1 range and R position																												
		Below specification in R position																												
		Below specification in 2 range																												
		Below specification when solenoid connector is disconnected																												
	Above specification in all ranges and R position																													
	Diagnostic trouble code	O/D OFF indicator light flashes																												

<input type="checkbox"/>	<input type="checkbox"/>	<input type="checkbox"/>	<input type="checkbox"/>	<input type="checkbox"/>	<input type="checkbox"/>	<input type="checkbox"/>	<input type="checkbox"/>	<input type="checkbox"/>	<input type="checkbox"/>	Vehicle does not move	1																									
<input type="checkbox"/>	<input type="checkbox"/>	<input type="checkbox"/>	<input type="checkbox"/>	<input type="checkbox"/>	<input type="checkbox"/>	<input type="checkbox"/>	<input type="checkbox"/>	<input type="checkbox"/>	<input type="checkbox"/>	Poor acceleration	2																									
<input type="checkbox"/>	<input type="checkbox"/>	<input type="checkbox"/>	<input type="checkbox"/>	<input type="checkbox"/>	<input type="checkbox"/>	<input type="checkbox"/>	<input type="checkbox"/>	<input type="checkbox"/>	<input type="checkbox"/>	Shifting not possible	3																									
<input type="checkbox"/>	<input type="checkbox"/>	<input type="checkbox"/>	<input type="checkbox"/>	<input type="checkbox"/>	<input type="checkbox"/>	<input type="checkbox"/>	<input type="checkbox"/>	<input type="checkbox"/>	<input type="checkbox"/>	Shift point high or low	4																									
<input type="checkbox"/>	<input type="checkbox"/>	<input type="checkbox"/>	<input type="checkbox"/>	<input type="checkbox"/>	<input type="checkbox"/>	<input type="checkbox"/>	<input type="checkbox"/>	<input type="checkbox"/>	<input type="checkbox"/>	Excessive shift shock	5																									
<input type="checkbox"/>	<input type="checkbox"/>	<input type="checkbox"/>	<input type="checkbox"/>	<input type="checkbox"/>	<input type="checkbox"/>	<input type="checkbox"/>	<input type="checkbox"/>	<input type="checkbox"/>	<input type="checkbox"/>	Excessive select shock	6																									
<input type="checkbox"/>	<input type="checkbox"/>	<input type="checkbox"/>	<input type="checkbox"/>	<input type="checkbox"/>	<input type="checkbox"/>	<input type="checkbox"/>	<input type="checkbox"/>	<input type="checkbox"/>	<input type="checkbox"/>	Engine speed flares up	7																									
<input type="checkbox"/>	<input type="checkbox"/>	<input type="checkbox"/>	<input type="checkbox"/>	<input type="checkbox"/>	<input type="checkbox"/>	<input type="checkbox"/>	<input type="checkbox"/>	<input type="checkbox"/>	<input type="checkbox"/>	Torque converter clutch operation not possible	8																									
<input type="checkbox"/>	<input type="checkbox"/>	<input type="checkbox"/>	<input type="checkbox"/>	<input type="checkbox"/>	<input type="checkbox"/>	<input type="checkbox"/>	<input type="checkbox"/>	<input type="checkbox"/>	<input type="checkbox"/>	Engine stalls	9																									
<input type="checkbox"/>	<input type="checkbox"/>	<input type="checkbox"/>	<input type="checkbox"/>	<input type="checkbox"/>	<input type="checkbox"/>	<input type="checkbox"/>	<input type="checkbox"/>	<input type="checkbox"/>	<input type="checkbox"/>	No engine braking	10																									
<input type="checkbox"/>	<input type="checkbox"/>	<input type="checkbox"/>	<input type="checkbox"/>	<input type="checkbox"/>	<input type="checkbox"/>	<input type="checkbox"/>	<input type="checkbox"/>	<input type="checkbox"/>	<input type="checkbox"/>	Engine starts in all ranges and R position	11																									
<input type="checkbox"/>	<input type="checkbox"/>	<input type="checkbox"/>	<input type="checkbox"/>	<input type="checkbox"/>	<input type="checkbox"/>	<input type="checkbox"/>	<input type="checkbox"/>	<input type="checkbox"/>	<input type="checkbox"/>	Vehicle moves in P or N positions	12																									
<input type="checkbox"/>	<input type="checkbox"/>	<input type="checkbox"/>	<input type="checkbox"/>	<input type="checkbox"/>	<input type="checkbox"/>	<input type="checkbox"/>	<input type="checkbox"/>	<input type="checkbox"/>	<input type="checkbox"/>	Engine does not start	13																									
Powertrain system										Item	No.																									
<table border="1"> <tr> <td colspan="2">3-4 clutch</td> <td colspan="2">2-4 brake band</td> <td colspan="2">Low and reverse brake</td> </tr> <tr> <td>Worn, defaced</td> <td>Spring malfunction</td> <td>Brake band worn, defaced</td> <td>Spring malfunction</td> <td>Piston stem long stroke</td> <td>Piston stem short stroke</td> </tr> <tr> <td>Worn defaced</td> <td>One-way clutch 1 slipping</td> <td>One-way clutch 2 slipping</td> <td></td> <td></td> <td></td> </tr> </table>										3-4 clutch		2-4 brake band		Low and reverse brake		Worn, defaced	Spring malfunction	Brake band worn, defaced	Spring malfunction	Piston stem long stroke	Piston stem short stroke	Worn defaced	One-way clutch 1 slipping	One-way clutch 2 slipping				Symptom		Cause of trouble		Inspection method		Result		Item
										3-4 clutch		2-4 brake band		Low and reverse brake																						
Worn, defaced	Spring malfunction	Brake band worn, defaced	Spring malfunction	Piston stem long stroke	Piston stem short stroke																															
Worn defaced	One-way clutch 1 slipping	One-way clutch 2 slipping																																		
Stall test		Time lag test		Line pressure test																																
<input type="checkbox"/>	<input type="checkbox"/>	<input type="checkbox"/>	<input type="checkbox"/>	<input type="checkbox"/>	<input type="checkbox"/>	<input type="checkbox"/>	<input type="checkbox"/>	<input type="checkbox"/>	<input type="checkbox"/>	Above specification in all ranges and R position	Stall test																									
<input type="checkbox"/>	<input type="checkbox"/>	<input type="checkbox"/>	<input type="checkbox"/>	<input type="checkbox"/>	<input type="checkbox"/>	<input type="checkbox"/>	<input type="checkbox"/>	<input type="checkbox"/>	<input type="checkbox"/>	Above specification in D range																										
<input type="checkbox"/>	<input type="checkbox"/>	<input type="checkbox"/>	<input type="checkbox"/>	<input type="checkbox"/>	<input type="checkbox"/>	<input type="checkbox"/>	<input type="checkbox"/>	<input type="checkbox"/>	<input type="checkbox"/>	Above specification in 2 range																										
<input type="checkbox"/>	<input type="checkbox"/>	<input type="checkbox"/>	<input type="checkbox"/>	<input type="checkbox"/>	<input type="checkbox"/>	<input type="checkbox"/>	<input type="checkbox"/>	<input type="checkbox"/>	<input type="checkbox"/>	Engine braking felt in 1 range	Stall test																									
<input type="checkbox"/>	<input type="checkbox"/>	<input type="checkbox"/>	<input type="checkbox"/>	<input type="checkbox"/>	<input type="checkbox"/>	<input type="checkbox"/>	<input type="checkbox"/>	<input type="checkbox"/>	<input type="checkbox"/>	Engine braking not felt in 1 range																										
<input type="checkbox"/>	<input type="checkbox"/>	<input type="checkbox"/>	<input type="checkbox"/>	<input type="checkbox"/>	<input type="checkbox"/>	<input type="checkbox"/>	<input type="checkbox"/>	<input type="checkbox"/>	<input type="checkbox"/>	Above specification in R position																										
<input type="checkbox"/>	<input type="checkbox"/>	<input type="checkbox"/>	<input type="checkbox"/>	<input type="checkbox"/>	<input type="checkbox"/>	<input type="checkbox"/>	<input type="checkbox"/>	<input type="checkbox"/>	<input type="checkbox"/>	Below specification in all ranges and R position	Time lag test																									
<input type="checkbox"/>	<input type="checkbox"/>	<input type="checkbox"/>	<input type="checkbox"/>	<input type="checkbox"/>	<input type="checkbox"/>	<input type="checkbox"/>	<input type="checkbox"/>	<input type="checkbox"/>	<input type="checkbox"/>	Above specification																										
<input type="checkbox"/>	<input type="checkbox"/>	<input type="checkbox"/>	<input type="checkbox"/>	<input type="checkbox"/>	<input type="checkbox"/>	<input type="checkbox"/>	<input type="checkbox"/>	<input type="checkbox"/>	<input type="checkbox"/>	Below specification																										
<input type="checkbox"/>	<input type="checkbox"/>	<input type="checkbox"/>	<input type="checkbox"/>	<input type="checkbox"/>	<input type="checkbox"/>	<input type="checkbox"/>	<input type="checkbox"/>	<input type="checkbox"/>	<input type="checkbox"/>	Above specification	Time lag test																									
<input type="checkbox"/>	<input type="checkbox"/>	<input type="checkbox"/>	<input type="checkbox"/>	<input type="checkbox"/>	<input type="checkbox"/>	<input type="checkbox"/>	<input type="checkbox"/>	<input type="checkbox"/>	<input type="checkbox"/>	Below specification																										
<input type="checkbox"/>	<input type="checkbox"/>	<input type="checkbox"/>	<input type="checkbox"/>	<input type="checkbox"/>	<input type="checkbox"/>	<input type="checkbox"/>	<input type="checkbox"/>	<input type="checkbox"/>	<input type="checkbox"/>	Above specification	Time lag test																									
<input type="checkbox"/>	<input type="checkbox"/>	<input type="checkbox"/>	<input type="checkbox"/>	<input type="checkbox"/>	<input type="checkbox"/>	<input type="checkbox"/>	<input type="checkbox"/>	<input type="checkbox"/>	<input type="checkbox"/>	Below specification																										
<input type="checkbox"/>	<input type="checkbox"/>	<input type="checkbox"/>	<input type="checkbox"/>	<input type="checkbox"/>	<input type="checkbox"/>	<input type="checkbox"/>	<input type="checkbox"/>	<input type="checkbox"/>	<input type="checkbox"/>	Above specification	Time lag test																									
<input type="checkbox"/>	<input type="checkbox"/>	<input type="checkbox"/>	<input type="checkbox"/>	<input type="checkbox"/>	<input type="checkbox"/>	<input type="checkbox"/>	<input type="checkbox"/>	<input type="checkbox"/>	<input type="checkbox"/>	Below specification																										
<input type="checkbox"/>	<input type="checkbox"/>	<input type="checkbox"/>	<input type="checkbox"/>	<input type="checkbox"/>	<input type="checkbox"/>	<input type="checkbox"/>	<input type="checkbox"/>	<input type="checkbox"/>	<input type="checkbox"/>	Below specification in all ranges and R position	Line pressure test																									
<input type="checkbox"/>	<input type="checkbox"/>	<input type="checkbox"/>	<input type="checkbox"/>	<input type="checkbox"/>	<input type="checkbox"/>	<input type="checkbox"/>	<input type="checkbox"/>	<input type="checkbox"/>	<input type="checkbox"/>	Below specification in D, 2, and 1 ranges																										
<input type="checkbox"/>	<input type="checkbox"/>	<input type="checkbox"/>	<input type="checkbox"/>	<input type="checkbox"/>	<input type="checkbox"/>	<input type="checkbox"/>	<input type="checkbox"/>	<input type="checkbox"/>	<input type="checkbox"/>	Below specification in 1 range and R position																										
<input type="checkbox"/>	<input type="checkbox"/>	<input type="checkbox"/>	<input type="checkbox"/>	<input type="checkbox"/>	<input type="checkbox"/>	<input type="checkbox"/>	<input type="checkbox"/>	<input type="checkbox"/>	<input type="checkbox"/>	Below specification in R position																										
<input type="checkbox"/>	<input type="checkbox"/>	<input type="checkbox"/>	<input type="checkbox"/>	<input type="checkbox"/>	<input type="checkbox"/>	<input type="checkbox"/>	<input type="checkbox"/>	<input type="checkbox"/>	<input type="checkbox"/>	Below specification in 2 range																										
<input type="checkbox"/>	<input type="checkbox"/>	<input type="checkbox"/>	<input type="checkbox"/>	<input type="checkbox"/>	<input type="checkbox"/>	<input type="checkbox"/>	<input type="checkbox"/>	<input type="checkbox"/>	<input type="checkbox"/>	Below specification when solenoid connector is disconnected																										
<input type="checkbox"/>	<input type="checkbox"/>	<input type="checkbox"/>	<input type="checkbox"/>	<input type="checkbox"/>	<input type="checkbox"/>	<input type="checkbox"/>	<input type="checkbox"/>	<input type="checkbox"/>	<input type="checkbox"/>	Above specification in all ranges and R position	Line pressure test																									
<input type="checkbox"/>	<input type="checkbox"/>	<input type="checkbox"/>	<input type="checkbox"/>	<input type="checkbox"/>	<input type="checkbox"/>	<input type="checkbox"/>	<input type="checkbox"/>	<input type="checkbox"/>	<input type="checkbox"/>	Below specification																										
<input type="checkbox"/>	<input type="checkbox"/>	<input type="checkbox"/>	<input type="checkbox"/>	<input type="checkbox"/>	<input type="checkbox"/>	<input type="checkbox"/>	<input type="checkbox"/>	<input type="checkbox"/>	<input type="checkbox"/>	O/D OFF indicator light flashes	Diagnostic trouble code																									
<input type="checkbox"/>	<input type="checkbox"/>	<input type="checkbox"/>	<input type="checkbox"/>	<input type="checkbox"/>	<input type="checkbox"/>	<input type="checkbox"/>	<input type="checkbox"/>	<input type="checkbox"/>	<input type="checkbox"/>	Diagnostic trouble code																										

BASIC INSPECTION

- Check the following before carrying out symptom troubleshooting.
- When a symptom is found while carrying out basic inspection, do the troubleshooting procedure on the page referred to at the bottom of each section.

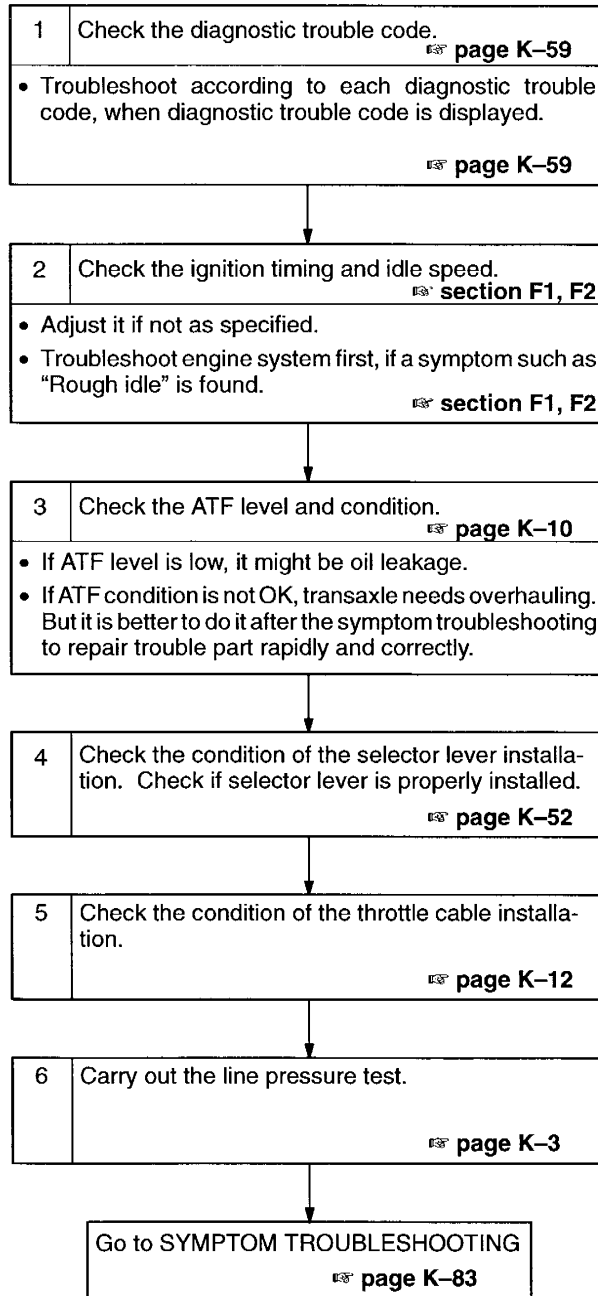

SYMPTOM TROUBLESHOOTING

1 Vehicle does not move

Verification of symptoms

Use the flow chart below to quickly and accurately determine the symptom and its cause, then follow the appropriate troubleshooting procedures.

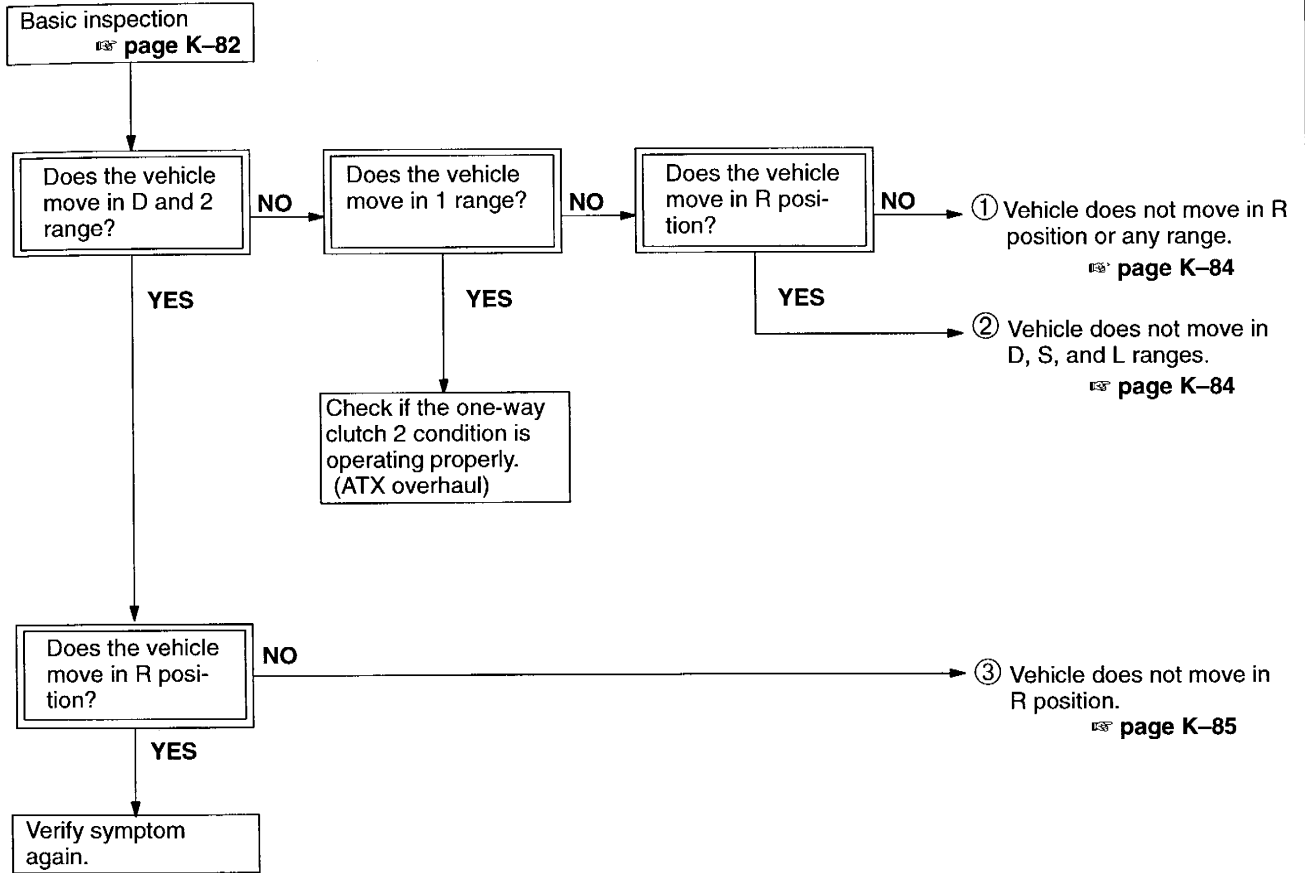

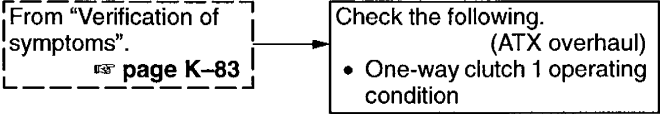
1-①	Vehicle does not move in R position or any range
Troubleshooting hints <ul style="list-style-type: none">• Throttle pressure below specification	
Troubleshooting flow  <pre>graph LR; A["From "Verification of symptoms". page K-83"] --> B["Check the following. (ATX overhaul)"]; B --> C["• One-way clutch 1 operating condition"]</pre>	

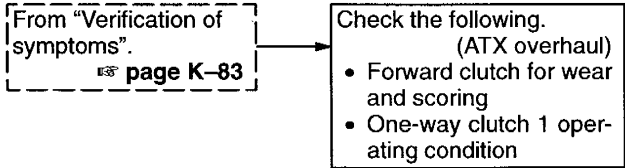
1-②	Vehicle does not move in D, 2, and 1 ranges
Troubleshooting hints <ul style="list-style-type: none">• Forward clutch slipping• One-way clutch 1 slipping	
Troubleshooting flow  <pre>graph LR; A["From "Verification of symptoms". page K-83"] --> B["Check the following. (ATX overhaul)"]; B --> C["• Forward clutch for wear and scoring"]; B --> D["• One-way clutch 1 operating condition"]</pre>	

1-③ Vehicle does not move in R position

Troubleshooting hints

- Low and reverse brake slipping
- Reverse clutch slipping
- Forward clutch burnt

Troubleshooting flow

From "Verification of symptoms".
page K-83

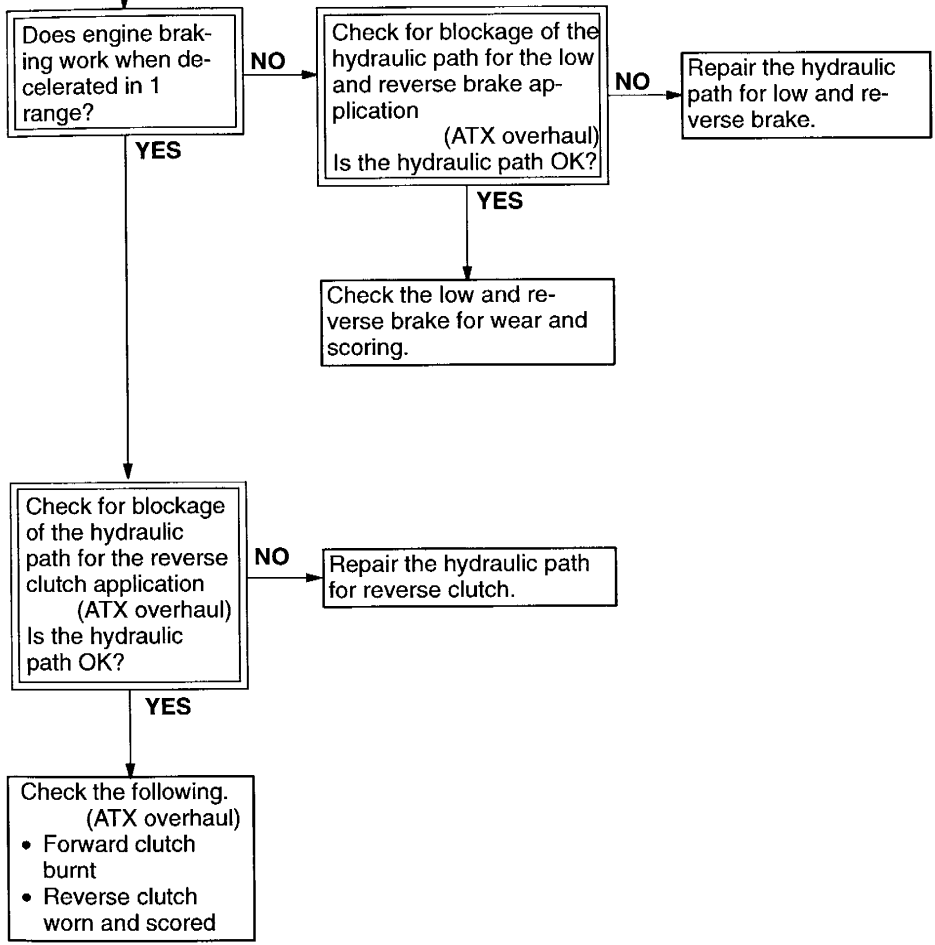

2 **Poor acceleration**

Troubleshooting hints

- Causes involving “3. Shifting not possible”
- Trouble with the engine system
- Braking effect
- High resistance due to damage of the transaxle

Troubleshooting flow

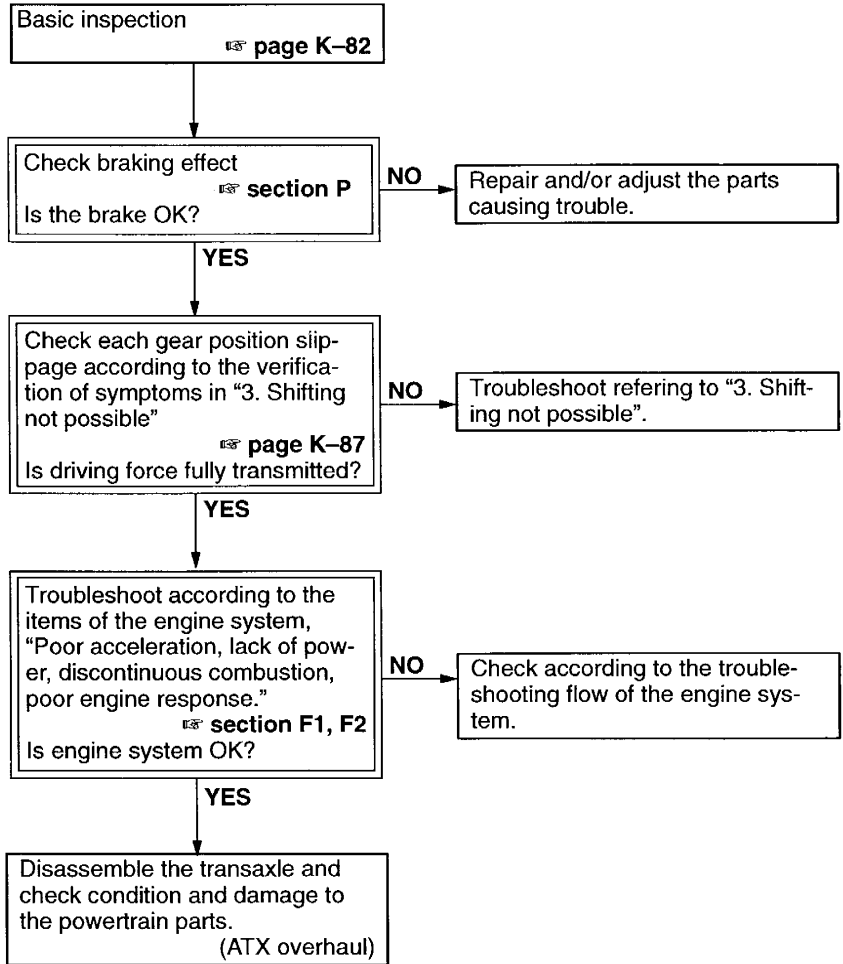

3 Shifting not possible

Verification of symptoms

- Use the flow chart below to quickly and accurately determine the symptom and its cause, then follow the appropriate troubleshooting procedures.
- Troubleshoot referring to road test (Refer to page K-8)

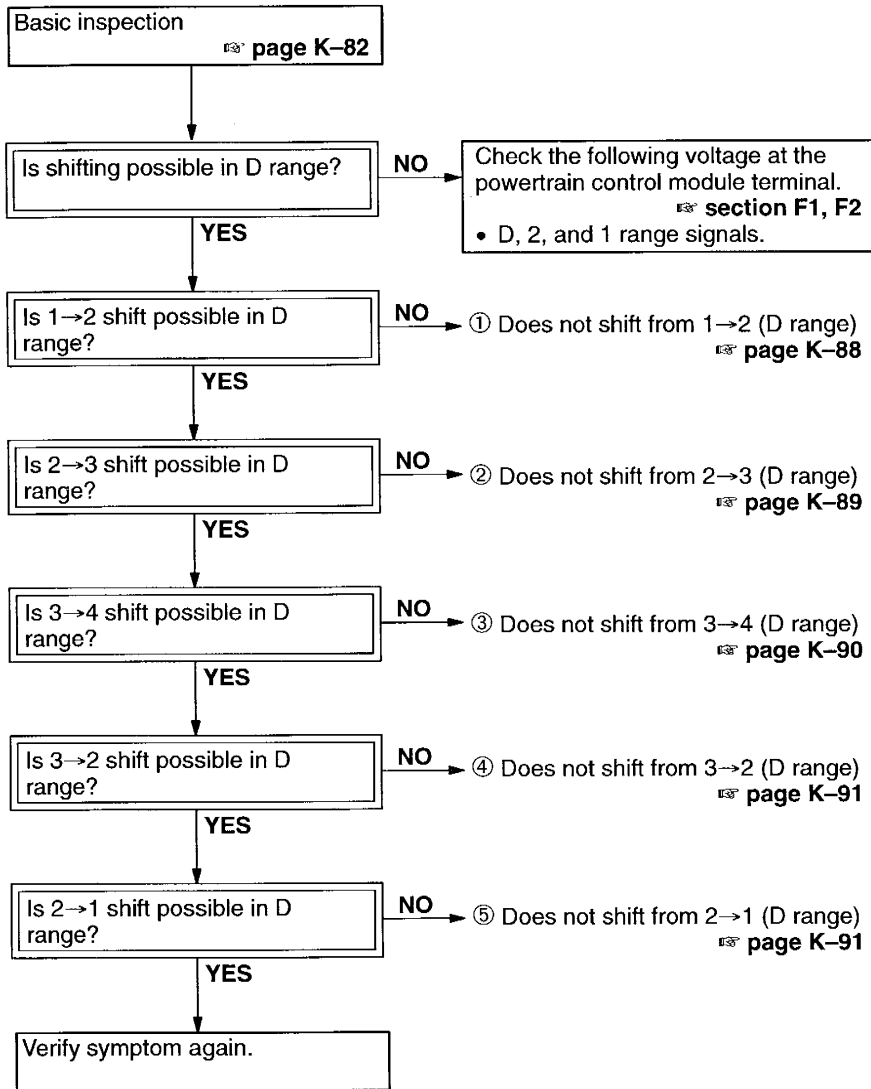

3-① Does not shift from 1→2 (D range)

Troubleshooting hints

- Malfunction of powertrain control module input signal
- No application of 2-4 brake band

Troubleshooting flow

From "Verification of symptoms"
☞ page K-87

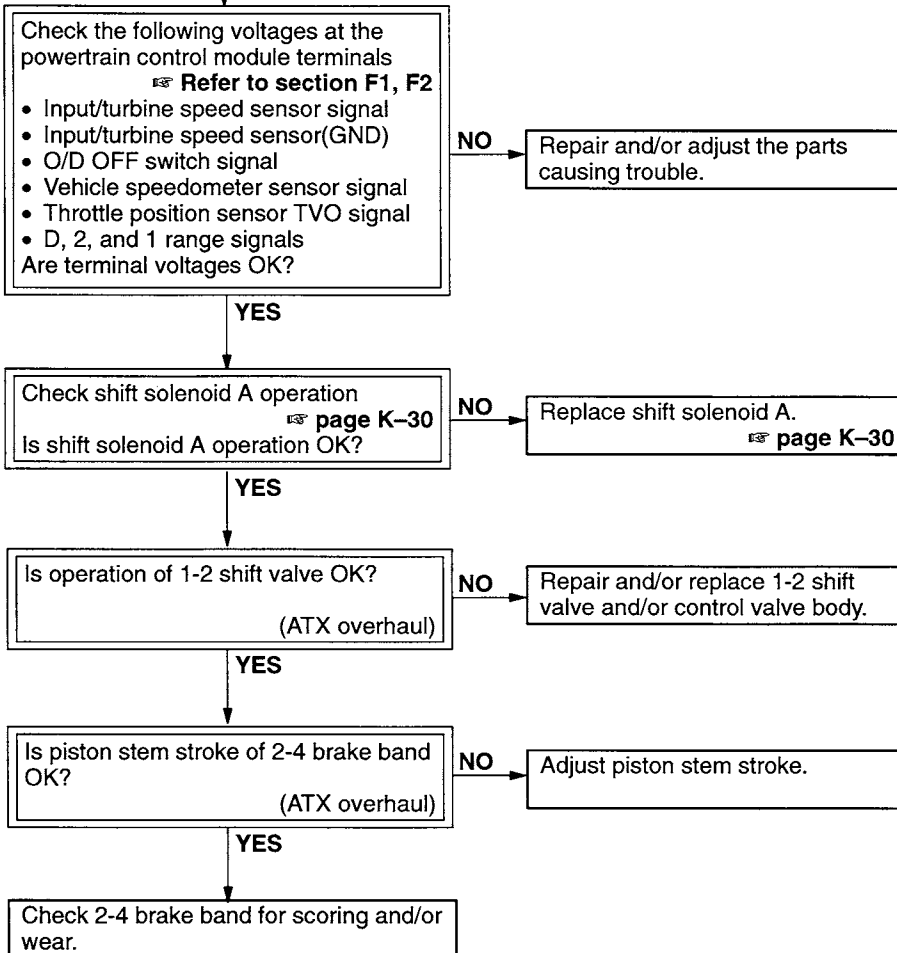

3-② Does not shift from 2→3 (D range)

Troubleshooting hints

- Malfunction of powertrain control module input signal
- No application of 3-4 clutch

Troubleshooting flow

From "Verification of symptoms"
page K-87

Does the vehicle start in third gear when solenoid valve connector is disconnected and all solenoid valves are OFF?

NO

Check shift solenoid B operation
page K-30
Is shift solenoid B operation OK?

NO

Replace shift solenoid B.
page K-30

YES

Check the following voltages at the powertrain control module terminals

- Input/turbine speed sensor signal
- Input/turbine speed sensor (GND)
- O/D OFF switch signal
- Vehicle speedometer sensor signal

Are terminal voltages OK?

NO

Repair and/or adjust the parts causing trouble.

YES

Check for poor connection of the connectors from powertrain control module to each part listed above.

YES

Check condition of 2-3 shift valve operation
(ATX overhaul)
Is 2-3 shift valve OK?

NO

Repair and/or replace 1-2 shift valve or control valve body.

YES

Check the following.
(ATX overhaul)

- Blockage of hydraulic path for 3-4 clutch application
- Scoring of 3-4 clutch friction element
- ATF leakage from the hydraulic path for 3-4 clutch application

3-③ Does not shift from 3→4 (D range)

Troubleshooting hints

- No drainage of 2-4 brake band released pressure
- Powertrain control module judges that fourth gear shifting is not possible

Troubleshooting flow

From "Verification of symptoms".
☞ page K-87

Do shift solenoids A voltages at powertrain control module terminals measure B+ at 3→4 shift point?
☞ section F1, F2

YES

NO

Check the following voltages at the powertrain control module terminals
☞ section F1, F2

- Engine coolant temperature sensor signal
- Transaxle fluid temperature sensor signal
- O/D OFF switch signal
- Throttle position sensor TVO signal
- D, 2, and 1 range signals
- Input/turbine speed sensor signal
- Input/turbine speed sensor (GND)

Are terminal voltages OK?

NO

Repair and/or adjust the parts causing trouble.

YES

Check for poor connection of connectors from powertrain control module to each part listed above.

Check operation of shift solenoid C
☞ page K-30
 Is operation of shift solenoid C OK?

YES

NO

Replace shift solenoid C.
☞ page K-30

Check operation of shift solenoid C.
 (ATX overhaul)

3- ④	Does not shift from 3→2 (D range)
Troubleshooting hints	
<ul style="list-style-type: none"> • Constant application of 3-4 clutch 	
Troubleshooting flow	
<div style="display: flex; justify-content: space-between; align-items: flex-start;"> <div style="border: 1px dashed black; padding: 5px; width: 20%;"> From "Verification of symptoms". <small>ES</small> page K-87 </div> <div style="width: 60%; text-align: center;"> <div style="border: 1px solid black; padding: 5px; width: 80%; margin: 0 auto;"> Does shift solenoid B voltage at powertrain control module terminal measure B+ on 3→2 shift point? <small>ES</small> section F1, F2 </div> <div style="display: flex; justify-content: center; margin-top: 5px;"> NO YES </div> <div style="border: 1px solid black; padding: 5px; width: 80%; margin: 0 auto; margin-top: 10px;"> Check for blockage of 2-3 shift valve drain port. (ATX overhaul) </div> </div> <div style="width: 15%; text-align: right;"> <div style="border: 1px solid black; padding: 5px; width: 80%; margin: 0 auto;"> Check for poor connection of the connectors from powertrain control module to shift solenoid B. </div> </div> </div>	

3- ⑤	Does not shift from 2→1 (D range)
Troubleshooting hints	
<ul style="list-style-type: none"> • No drainage of 2-4 brake band applied pressure 	
Troubleshooting flow	
<div style="display: flex; justify-content: space-between; align-items: center;"> <div style="border: 1px dashed black; padding: 5px; width: 20%;"> From "Verification of symptoms". <small>ES</small> page K-87 </div> <div style="width: 70%; text-align: center;"> <div style="border: 1px solid black; padding: 5px; width: 80%; margin: 0 auto;"> Check blockage of 1-2 shift valve drain port. (ATX overhaul) </div> </div> </div>	

4

Shift point high or low

Troubleshooting hints

- Powertrain control module selects wrong mode

Troubleshooting flow

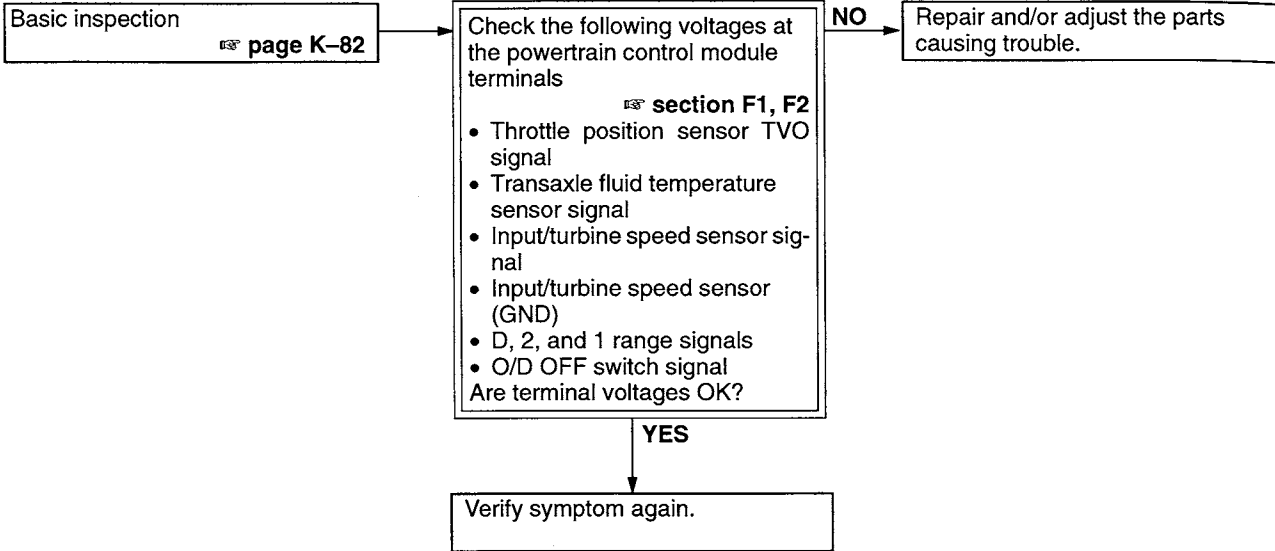

5 Excessive shift shock

Verification of symptoms

- Use the flow chart below to quickly and accurately determine the symptom and its cause, then follow the appropriate troubleshooting procedures.
- Troubleshoot referring to road test. (Refer to page K-8)

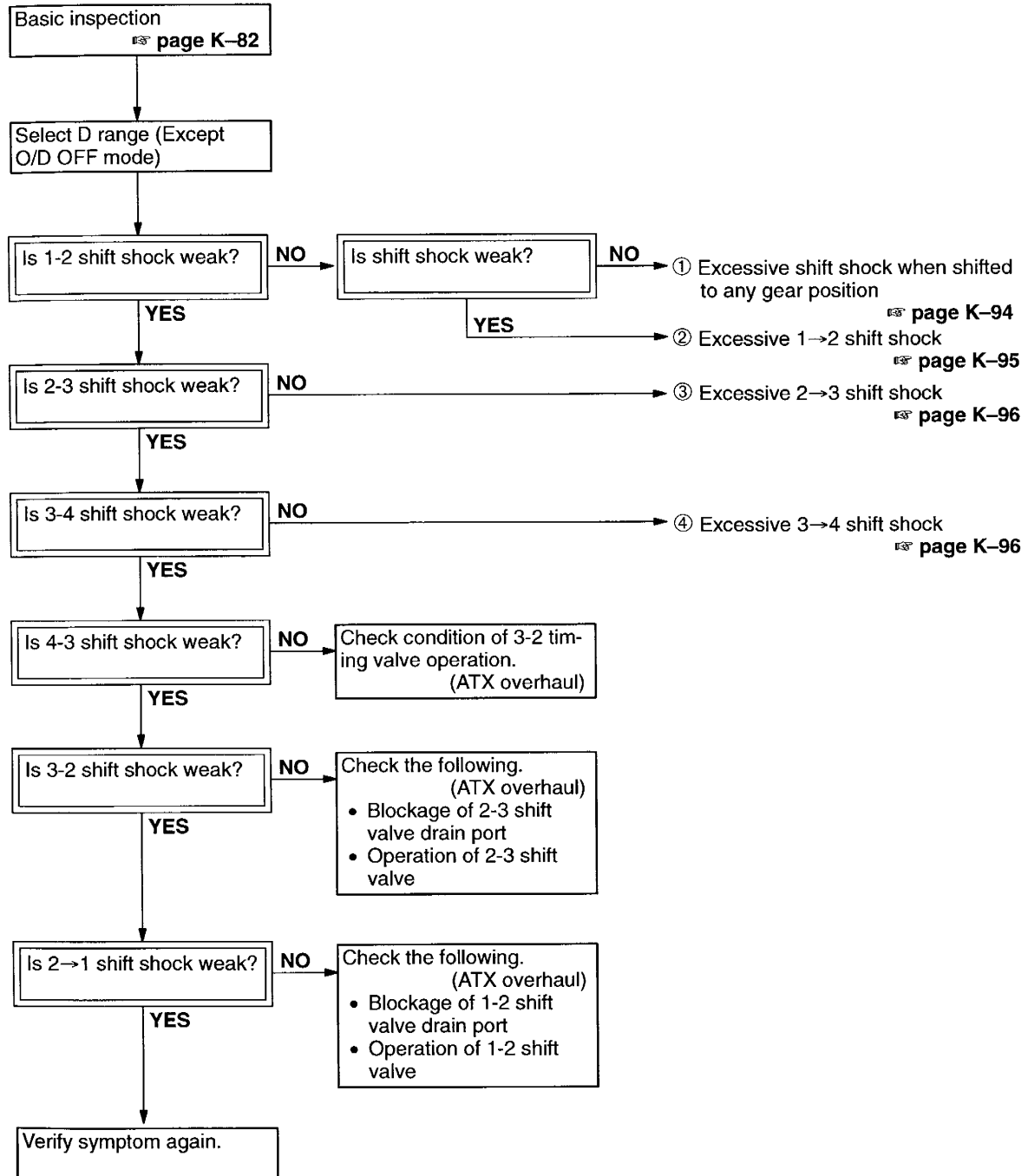

5-① Excessive shift shock when shifted to any gear position

Troubleshooting hints

- Powertrain control module input signal malfunction
- Torque converter clutch not released

Troubleshooting flow

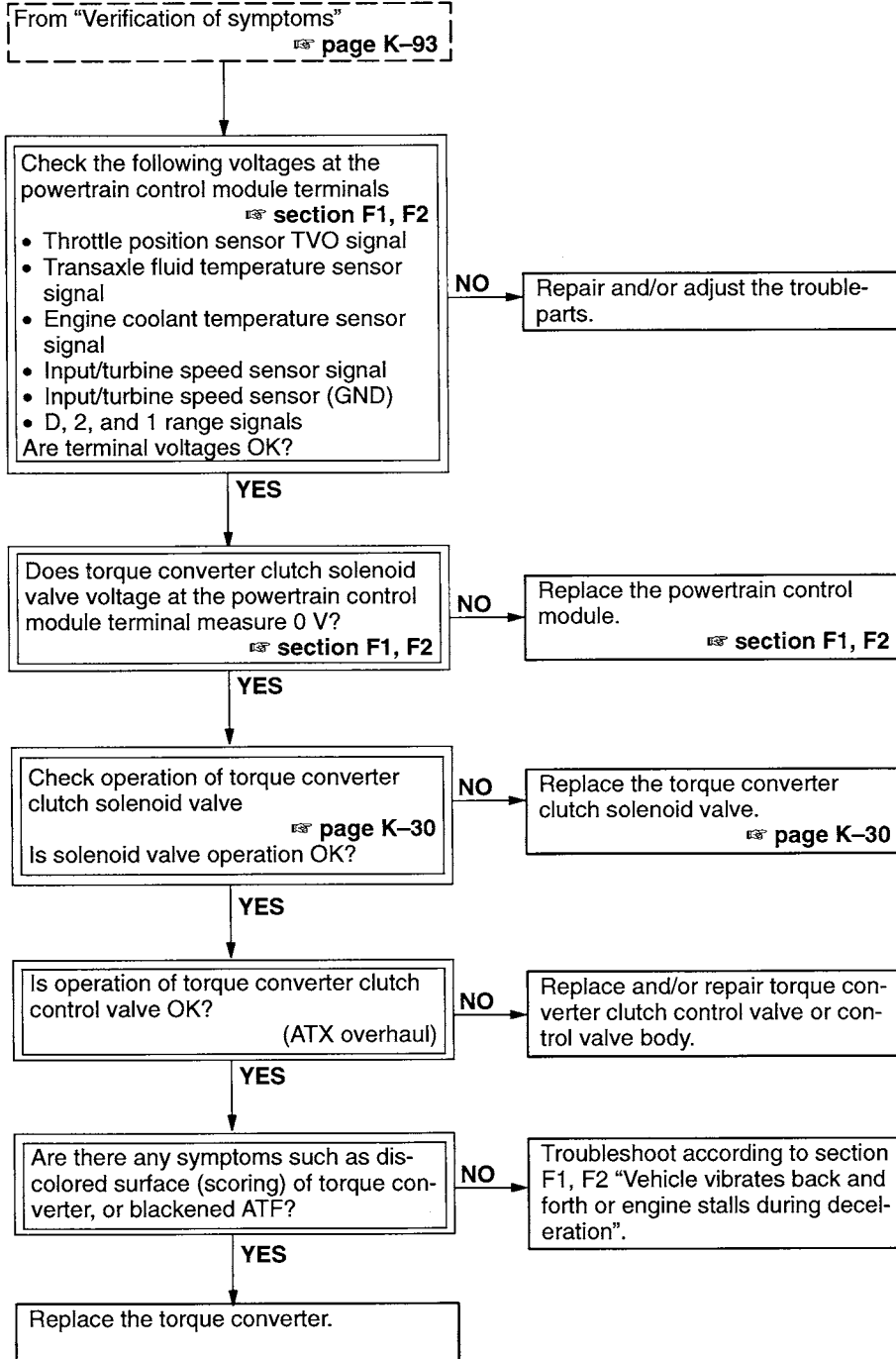

5- ② Excessive 1→2 shift shock

Troubleshooting hints

- Malfunction of 1-2 accumulator operation
- Blockage of hydraulic path for 2-4 brake application
- Damage to return spring of 2-4 brake band

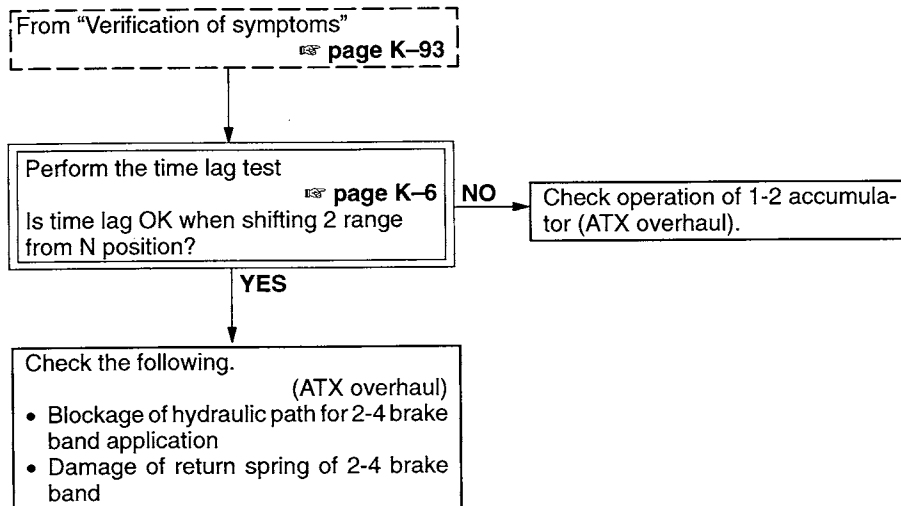
Troubleshooting flow

5- ③ Excessive 2→3 shift shock

Troubleshooting hints

- Malfunction of 2-3 accumulator operation
- Malfunction of bypass valve
- Late release of 2-4 brake band
- Early/late release of 3-4 clutch application
- 3-4 clutch worn and/or scored

Troubleshooting flow

From "Verification of symptoms"

☞ page K-93

Check the following.

(ATX overhaul)

- Operation of 2-3 accumulator
- Bypass valve
- Blockage of hydraulic path for 2-4 brake band release
- 3-4 clutch worn and/or scored
- Damage to 3-4 clutch return spring
- Blockage of hydraulic path for 3-4 clutch application

5- ④ Excessive 3→4 shift shock

Troubleshooting hints

- Late drainage of 2-4 brake band pressure
- 2-4 brake band worn and/or scored

Troubleshooting flow

From "Verification of symptoms"

☞ page K-93

Check the following.

(ATX overhaul)

- Blockage of 3-4 shift valve drain port
- Operation of 3-4 shift valve
- 2-4 brake band for wear and/or scoring

6

Excessive select shock

Verification of symptoms

- Use the flow chart below to quickly and accurately determine the symptom and its cause, then follow the appropriate troubleshooting procedures.

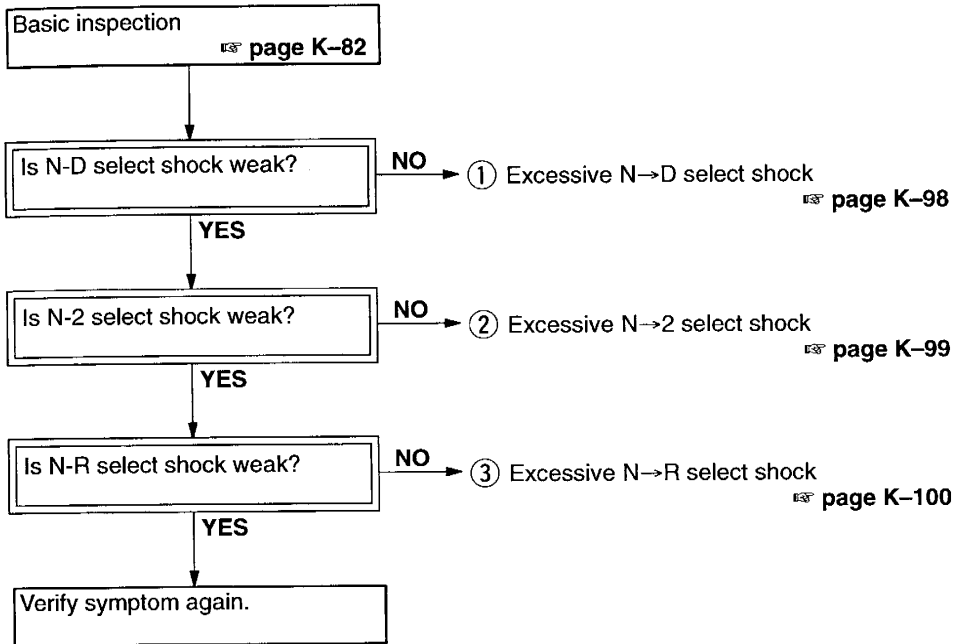

6-① Excessive N→D select shock

Troubleshooting hints

- Powertrain control module input signal malfunction
- Malfunction of N-D accumulator operation
- Damage to forward clutch dish plate
- Damage to forward clutch return spring

Troubleshooting flow

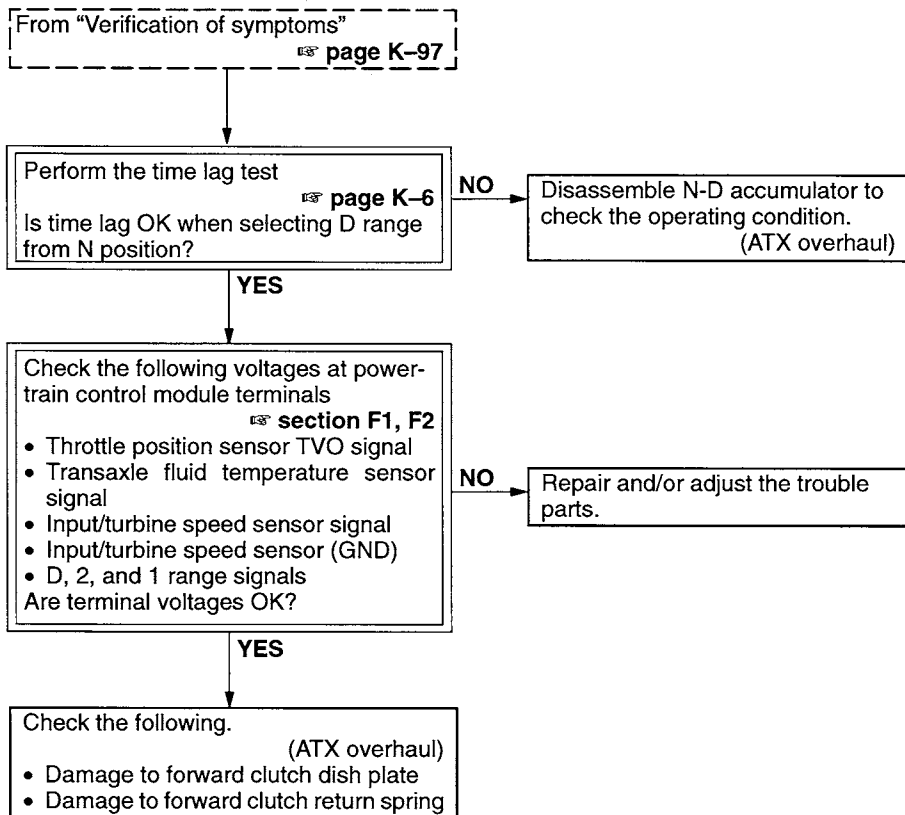

6-② Excessive N→2 select shock

Troubleshooting hints

- Malfunction of 1-2 accumulator operation
- Piston stem short stroke of 2-4 brake band
- Damage to 2-4 brake band return spring
- Damage to coasting clutch dish plate.

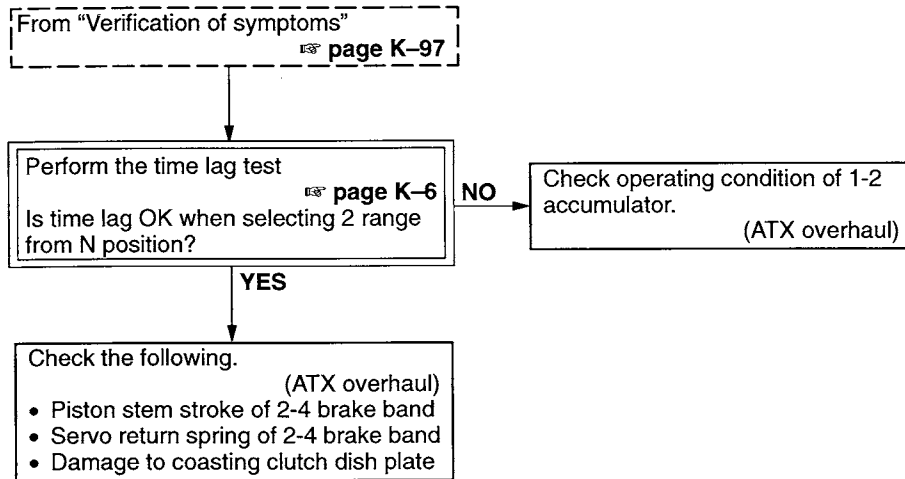
Troubleshooting flow

6-③ Excessive N→R select shock

Troubleshooting hints

- Damage to low and reverse brake dish plate
- Malfunction of N-R accumulator operation

Troubleshooting flow

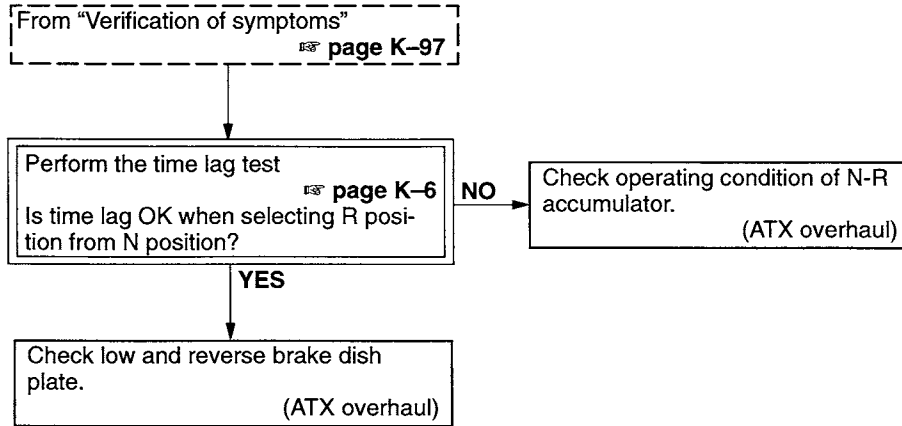

7 Engine speed flares up

Verification of symptoms

- Use the flow chart below to quickly and accurately determine the symptom and its cause, then follow the appropriate troubleshooting procedures.
- Troubleshoot referring to road test (Refer to page K-8)

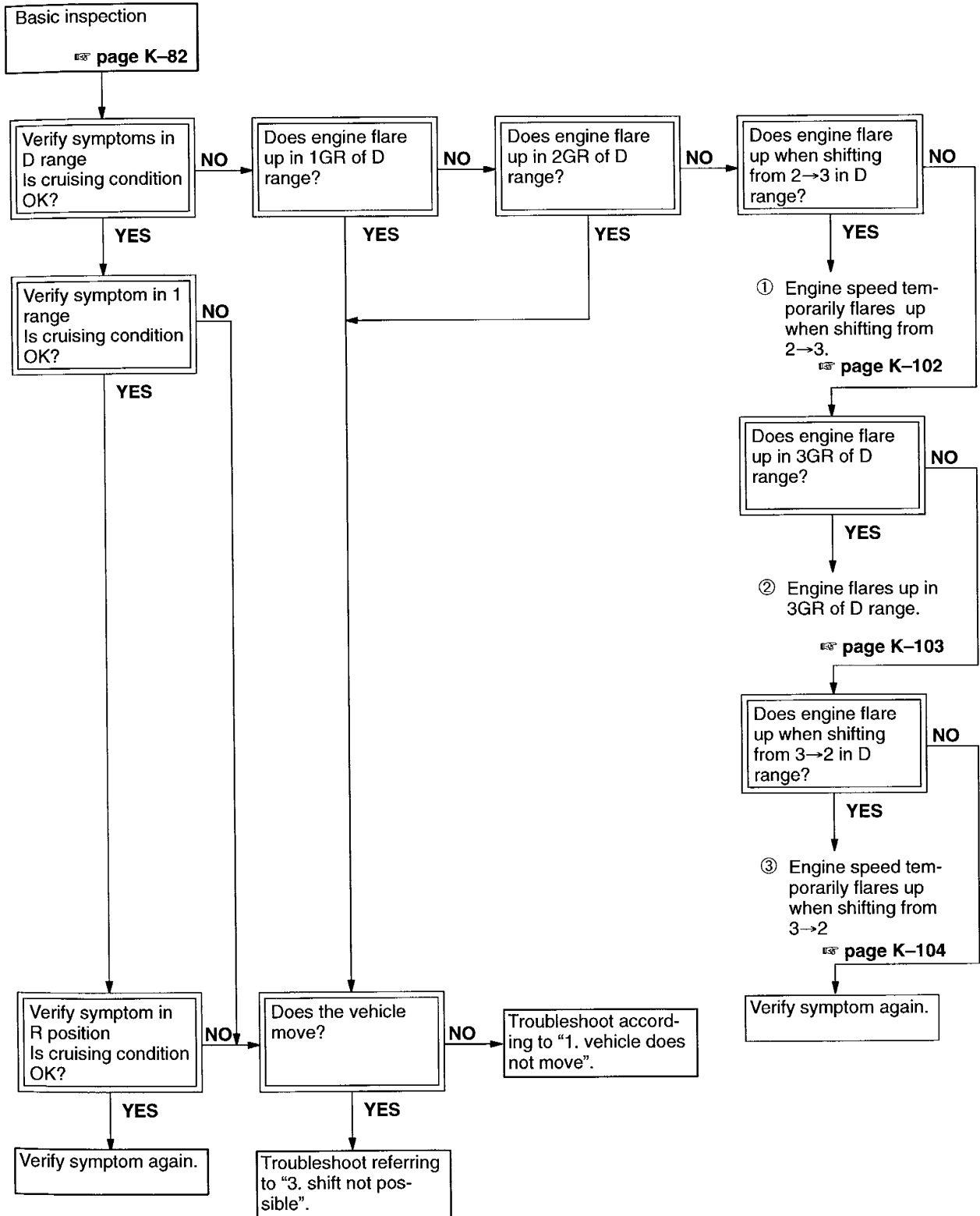

7-① Engine speed temporarily flares up when shifting from 2→3

Troubleshooting hints

- Late application of 3-4 clutch
- 3-4 clutch worn
- Malfunction of bypass valve operation

Troubleshooting flow

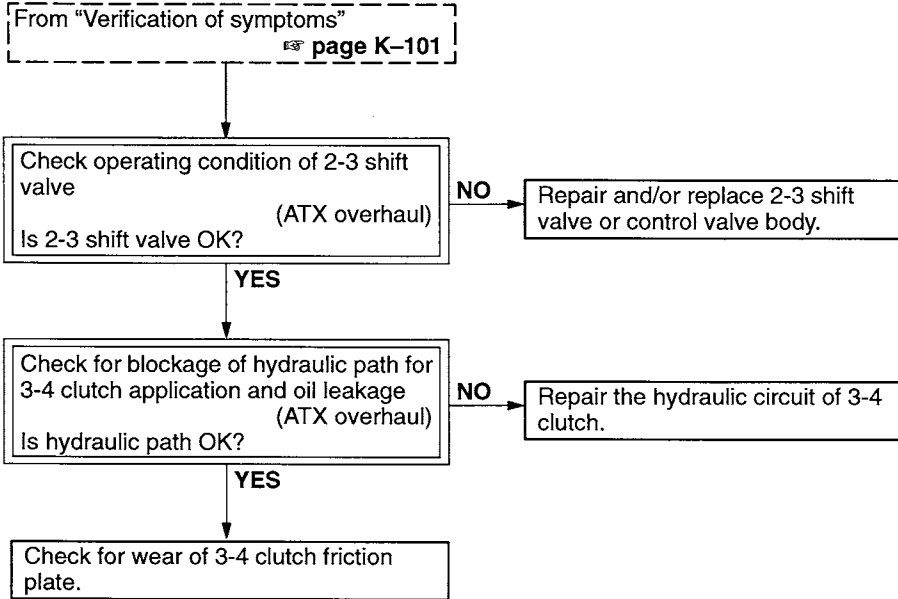

7-② Engine speed flares up in 3GR of D and S range

Troubleshooting hints

- No application of 3-4 clutch (in first gear condition)

Troubleshooting flow

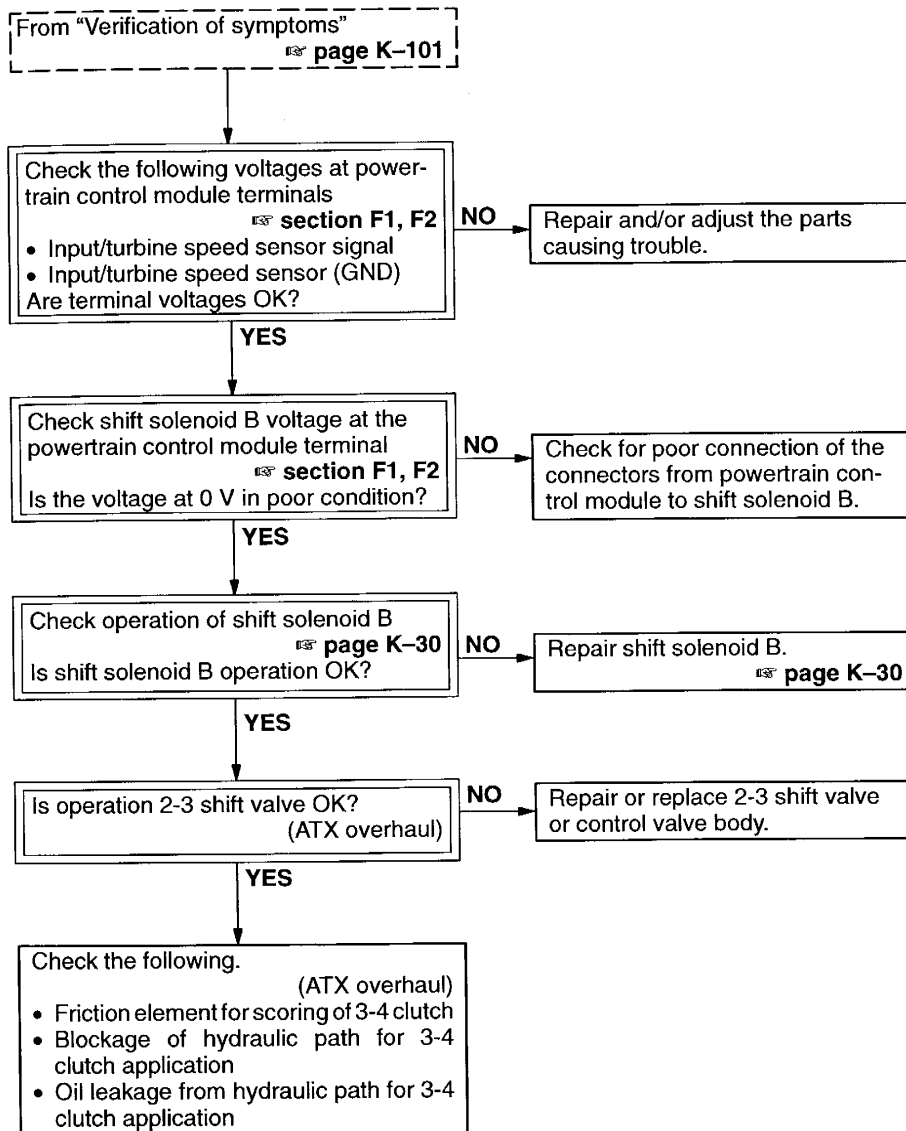

7- ③ Engine speed temporarily flares up when shifting from 3→2

Troubleshooting hints

- Late application of 2-4 brake band

Troubleshooting flow

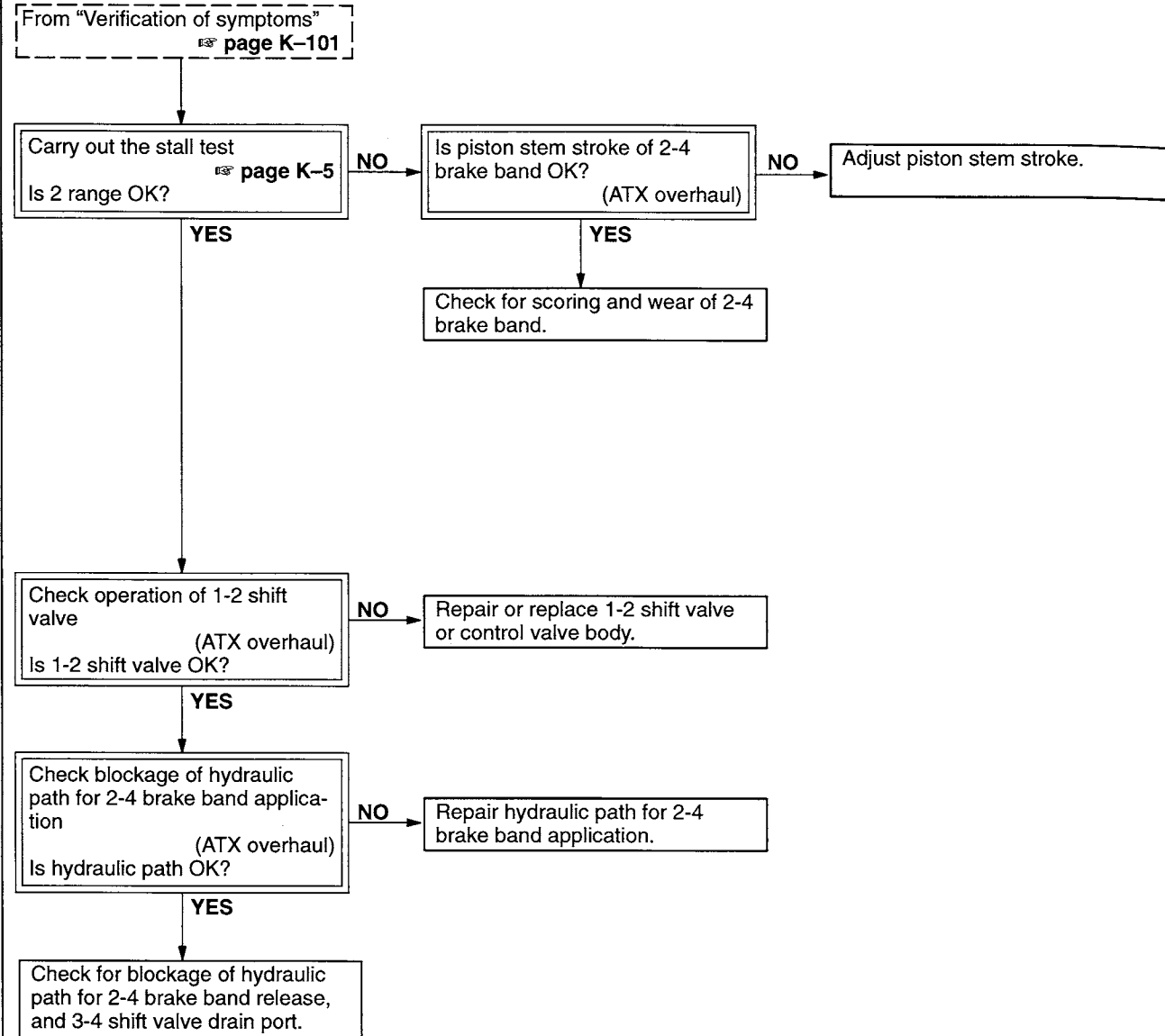

8

Torque converter clutch operation not possible

Troubleshooting hints

- Torque converter pressure low
- No application of torque converter clutch
- Transaxle control module inhibits torque converter clutch operation

Troubleshooting flow

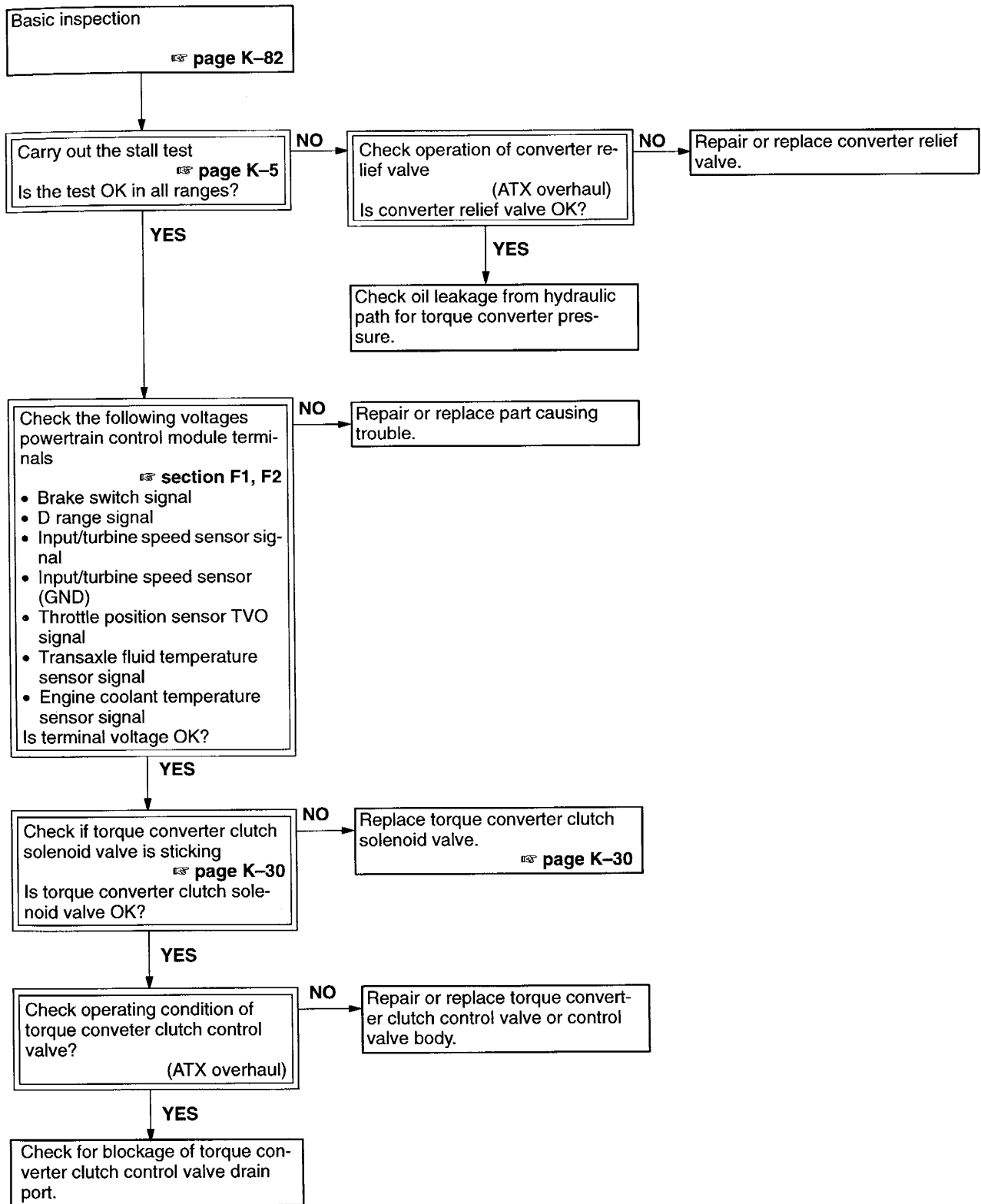

9

Engine stalls

Troubleshooting hints

- Constant application of torque converter clutch piston

Troubleshooting flow

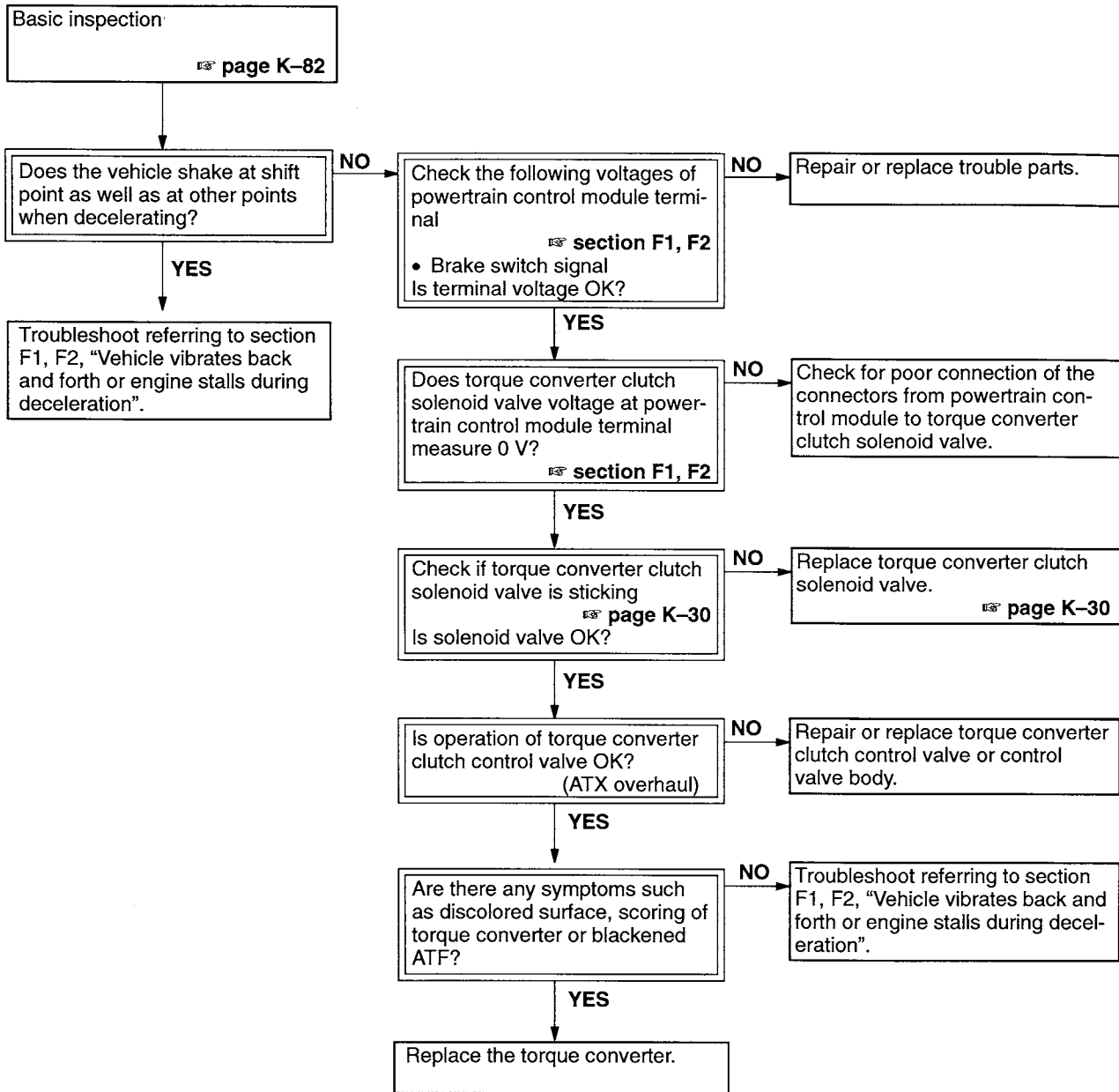

10	No engine braking
<p>Verification of symptoms</p> <p>Use the flowchart below to quickly and accurately determine the symptom and its cause, then follow the appropriate troubleshooting procedures.</p>	
<div style="border: 1px solid black; padding: 5px; width: fit-content; margin: 0 auto;">Basic inspection <small>ES</small> page K-82</div>	
<pre> graph TD A[Basic inspection <small>ES</small> page K-82] --> B{Are there any symptoms found such as engine flare?} B -- YES --> C[Troubleshoot according to appli- cable item for each symptom.] B -- NO --> D{Does engine braking work in 2 and 1 ranges?} D -- YES --> E[Verify symptom again.] D -- NO --> F[① No engine braking in 2 and 1 ranges <small>ES</small> page K-107] </pre>	

10- ①	No engine braking in 2 and 1 ranges mode
<p>Troubleshooting hints</p> <ul style="list-style-type: none"> • No application of coasting clutch 	
<p>Troubleshooting flow</p>	
<div style="border: 1px dashed black; padding: 5px; width: fit-content; margin: 0 auto;">From "Verification of symptoms" <small>ES</small> page K-107</div> <div style="border: 1px solid black; padding: 5px; width: fit-content; margin: 0 auto; margin-top: 10px;"> <p>Check the following. (ATX overhaul)</p> <ul style="list-style-type: none"> • Blockage of hydraulic path for coasting clutch application • Friction element for wear and scoring of coasting clutch </div>	

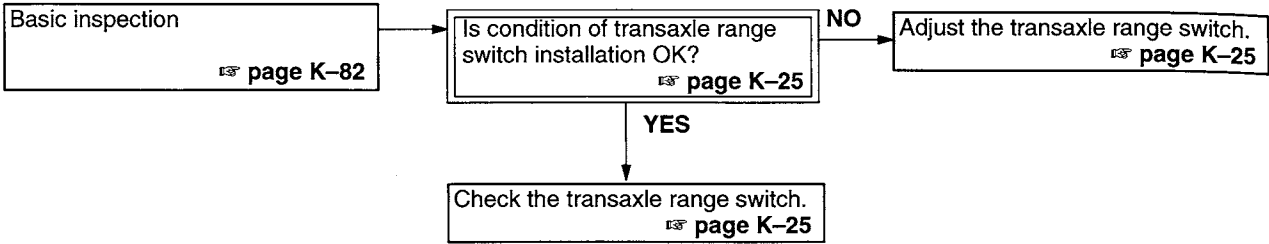
11	Will start in positions other than P or N positions
Troubleshooting hints	
<ul style="list-style-type: none"> • Damage inside transaxle range switch 	
Troubleshooting flow	
 <pre> graph LR A[Basic inspection page K-82] --> B{Is condition of transaxle range switch installation OK? page K-25} B -- NO --> C[Adjust the transaxle range switch. page K-25] B -- YES --> D[Check the transaxle range switch. page K-25] </pre>	

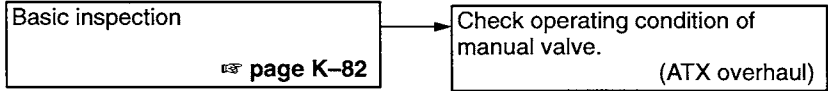
12	Vehicle moves in P or N position
Troubleshooting hints	
<ul style="list-style-type: none"> • No transaxle of selector lever movement to manual valve 	
Troubleshooting flow	
 <pre> graph LR A[Basic inspection page K-82] --> B[Check operating condition of manual valve. (ATX overhaul)] </pre>	

Before beginning any service procedure, refer to section T1 of this manual for air bag system service warnings.

FRONT AND REAR AXLES

OUTLINE	M- 2
SPECIFICATIONS	M- 2
GENERAL PROCEDURES	M- 2
FRONT AXLE	M- 3
PREPARATION	M- 3
WHEEL HUB, STEERING KNUCKLE	M- 4
REAR AXLE	M- 9
PREPARATION	M- 9
WHEEL HUB, HUB SPINDLE	M- 9
DRIVE SHAFT	M-13
PREPARATION	M-13
JOINT SHAFT	M-14
DRIVE SHAFT	M-18

OUTLINE

SPECIFICATIONS

Item	Engine		Z5		BP	
	Transaxle		MTX	ATX	MTX	ATX
Front axle						
Wheel bearing type	Angular ball bearing					
Maximum wheel bearing play	mm { in }	0.05 { 0.002 }				
Rear axle						
Wheel bearing type	Unitized angular ball bearing					
Maximum wheel bearing play	mm { in }	0.05 { 0.002 }				
Drive shaft						
Joint type	Wheel side	Bell joint				
	Differential side	Tripod joint				
Length of joint (Between center of joint)	Right side	380.5 { 14.98 }		429.9 { 16.93 }		
	Left side	397.5 { 15.65 }	393.5 { 15.49 }	372.4 { 14.66 }	390.3 { 15.37 }	
Shaft diameter	Right side	23 { 0.91 }				
	Left side					
Length of joint shaft	mm { in }	372.4 { 14.66 }	375.4 { 14.78 }	339.6 { 13.37 }	326.9 { 12.87 }	
Joint shaft diameter	26 { 1.0 }					

GENERAL PROCEDURES

Removal / Installation, Disassembly / Assembly

- The numbers in the structural view indicate the removal and disassembly order. For installation and assembly, follow the reverse order.

Wheels and tires

- The removal and installation procedures for the wheels and tires are not mentioned in this section. If you must remove a wheel, retighten it to **89—127 N·m { 9.0—13.0 kgf·m , 66—94 ft·lbf }**.

Brake lines

Caution

- **Brake fluid will damage painted surfaces. If brake fluid does get on a painted surface, wipe it off immediately.**
- Tighten the brake pipe flare nut by using the **SST (49 0259 770B)**. Be sure to modify the brake pipe flare nut tightening torque to allow for use of a torque wrench-SST combination. (Refer to section GI "Torque Formulas".)
- If a brake line(s) has been disconnected anytime during the procedure, add brake fluid, bleed the brakes, and inspect for leakage after the procedure has been completed.

FRONT AXLE

PREPARATION
SST

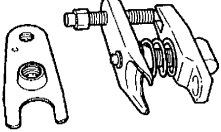
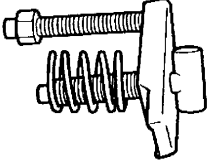
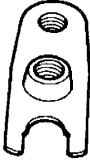
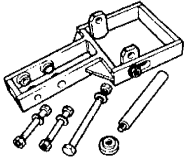
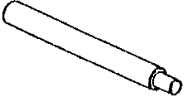
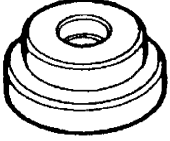
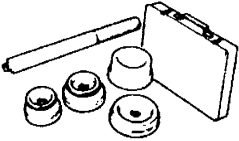
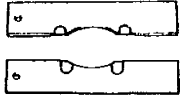
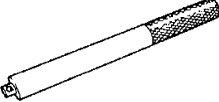
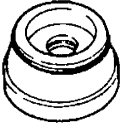
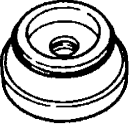
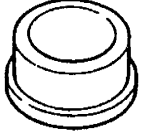
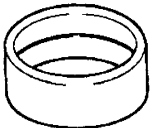
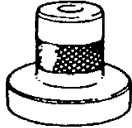
<p>49 T028 3A0 Puller set, ball joint</p> 	<p>For removal of hub bolt</p>	<p>49 T028 303 Body (Part of 49 T028 3A0)</p> 	<p>For removal of hub bolt</p>
<p>49 T028 304 Attachment (Part of 49 T028 3A0)</p> 	<p>For removal of hub bolt</p>	<p>49 B026 1A0 Puller set, wheel hub</p> 	<p>For removal of wheel bearing</p>
<p>49 G033 102 Handle (Part of 49 B026 1A0)</p> 	<p>For removal of wheel hub</p>	<p>49 G030 727 Attachment (Part of 49 B026 1A0)</p> 	<p>For removal of wheel hub</p>
<p>49 F027 0A1 Installer set, bearing</p> 	<p>For installation of wheel hub assembly and wheel bearing</p>	<p>49 F026 103 Puller, wheel hub</p> 	<p>For removal of wheel hub</p>
<p>49 F027 003 Handle (Part of 49 F027 0A1)</p> 	<p>For removal of front bearing</p>	<p>49 F027 005 Attachment 62 (Part of 49 F027 0A1)</p> 	<p>For removal of wheel bearing</p>
<p>49 F027 007 Attachment 72 (Part of 49 F027 0A1)</p> 	<p>For installation of wheel bearing</p>	<p>49 F027 009 Attachment 68 & 77 (Part of 49 F027 0A1)</p> 	<p>For installation of wheel bearing</p>
<p>49 E033 101 Installer, dust cover</p> 	<p>For installation of dust cover</p>	<p>49 V001 795 Installer, oil seal</p> 	<p>For installation of oil seal</p>

M

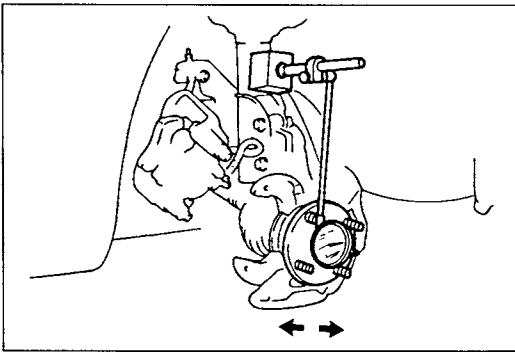

WHEEL HUB, STEERING KNUCKLE

Preinspection

Wheel bearing play

1. Remove the brake caliper assembly and disc plate.
2. Position a dial indicator against the wheel hub. Push and pull the wheel hub by hand in the axial direction and measure the wheel bearing play.
3. If the bearing play exceeds the specification, check and adjust the locknut torque or replace the wheel bearing if necessary. (Refer to page M-5.)

Max. wheel bearing play: 0.05 mm { 0.002 in }

On-vehicle service

Wheel hub bolt replacement

1. Remove the hub bolt by using the SSTs.

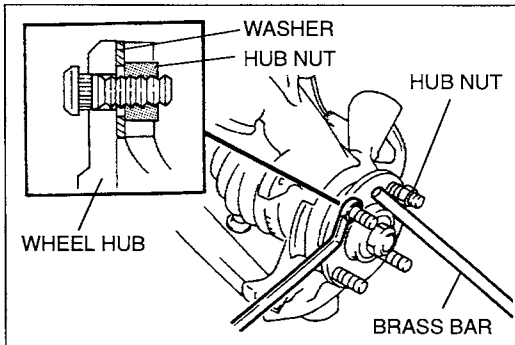
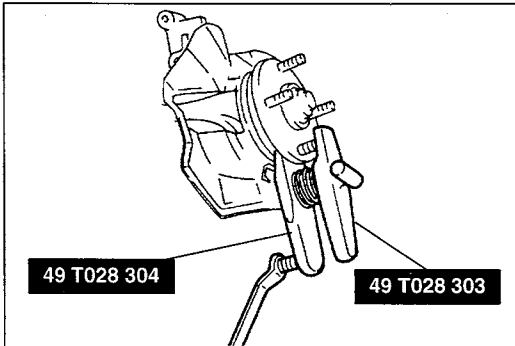

2. As shown in the figure, install the hub bolt into the wheel hub and set a washer and hub nut in the hub bolt.
3. Tighten the hub nut while holding the wheel hub by using the brass bar.

Removal / Inspection / Installation

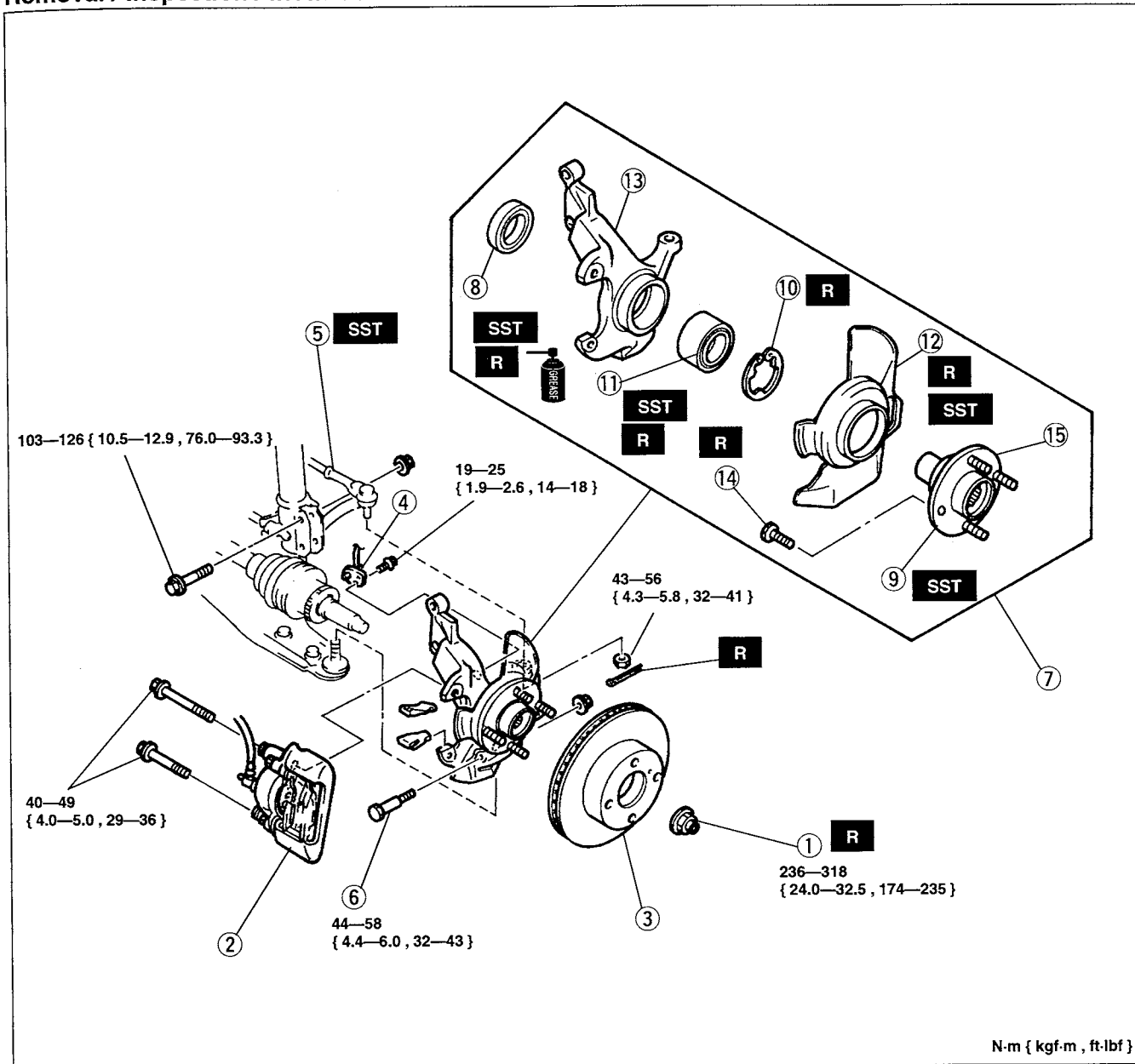

- | | |
|---|---|
| <p>1. Locknut
Removal Note page M-6
Installation Note page M-8</p> <p>2. Brake caliper assembly
Service section P</p> <p>3. Disc plate
Service section P</p> <p>4. ABS wheel-speed sensor
Service section P</p> <p>5. Tie-rod end
Service section N</p> <p>6. Lower arm ball joint bolt</p> <p>7. Front wheel hub, steering knuckle
Inspect wheel hub for damage and rough rotation</p> <p>8. Oil seal
Installation Note page M-8</p> | <p>9. Wheel hub assembly
Removal Note page M-6
Installation Note page M-8</p> <p>10. Snap ring</p> <p>11. Wheel bearing
Removal Note page M-6
Installation Note page M-7</p> <p>12. Dust cover
Removal Note page M-6
Installation Note page M-7</p> <p>13. Steering knuckle
Inspect for cracks and damage</p> <p>14. Hub bolt
Removal Note page M-7
Installation Note page M-7</p> <p>15. Wheel hub</p> |
|---|---|

N-m { kgf-m , ft-lbf }

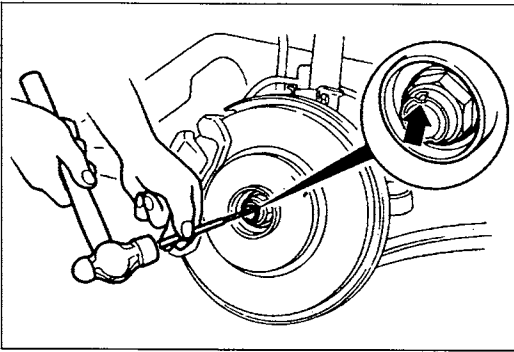
**Removal note****Locknut**

1. Raise the staked portion of the locknut by using a chisel.
2. Lock the hub by applying the brakes.
3. Remove the locknut.

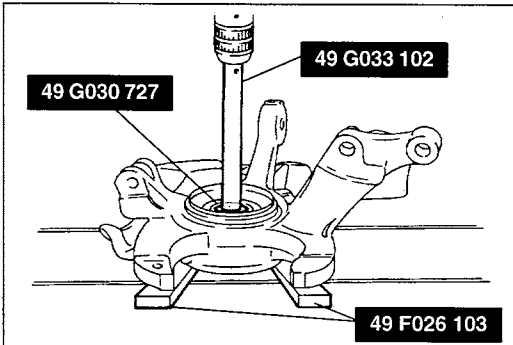
**Wheel hub assembly**

1. Remove the front wheel hub assembly by using the SSTs.

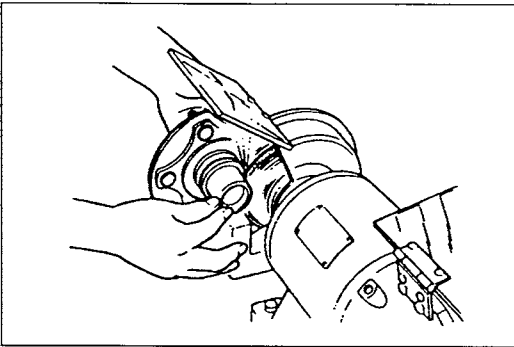

2. If the bearing inner race remains on the front wheel hub assembly, grind a section of the bearing inner race until approximately **0.5 mm { 0.02 in }** remains. Then remove it by using a chisel.

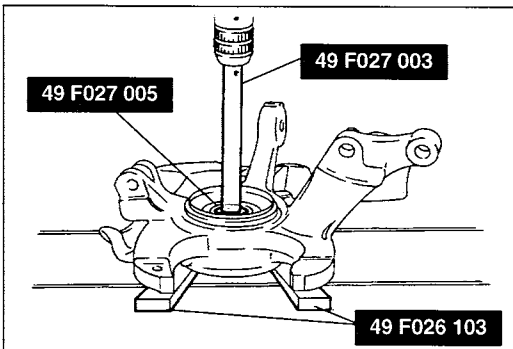
**Wheel bearing**

Press out the wheel bearing by using the SSTs.

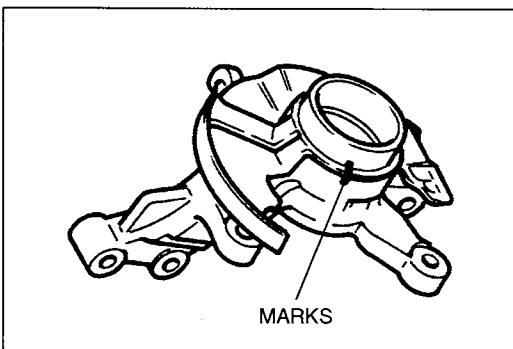
**Dust cover****Note**

- The dust cover does not need to be removed unless you are replacing it.

1. Mark the dust cover and steering knuckle for proper reassembly.
2. Remove the dust cover by using a chisel.

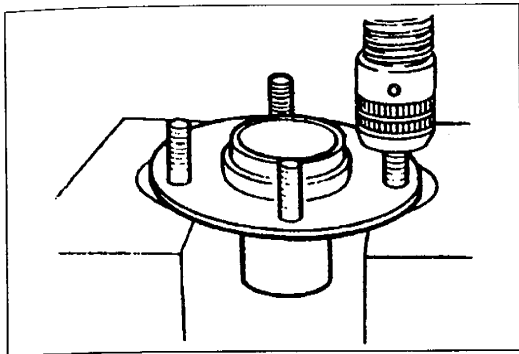

Hub bolt

Note

- The hub bolts do not need to be removed unless you are replacing them.

Press out the hub bolts.

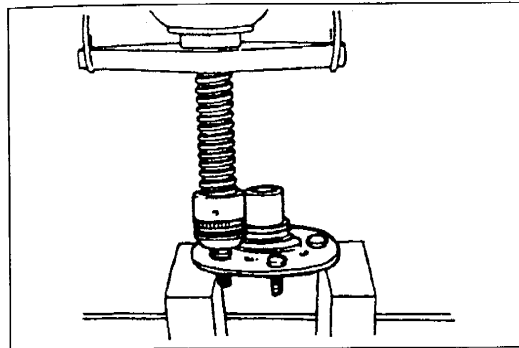

Installation note

Hub bolt

Press in new hub bolts.

M

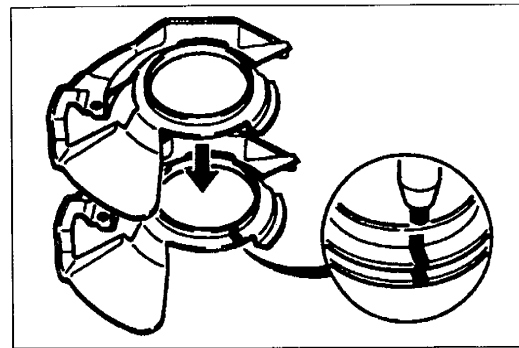

Dust cover

1. Mark the new dust cover in the same manner as the one removed.

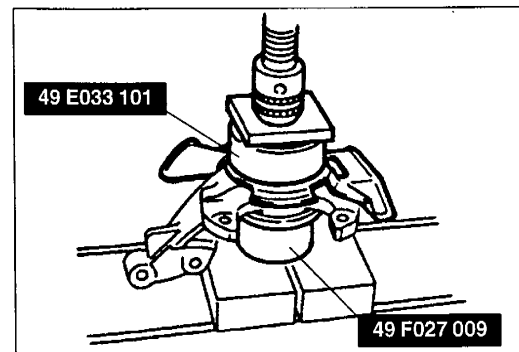

2. Align the marks of the new dust cover and the steering knuckle.

3. Press in the dust cover by using a steel plate and the SSTs.

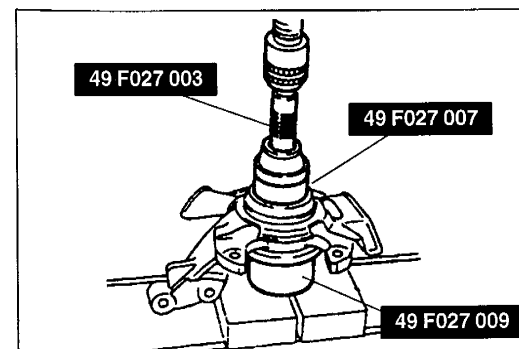

Wheel bearing

Press in the new wheel bearing by using the SSTs.

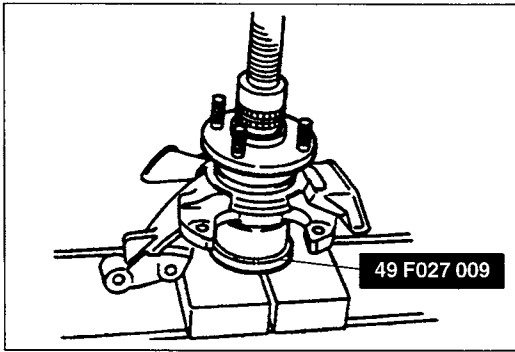

Wheel hub assembly

Press in the front wheel hub assembly by using the **SST**.

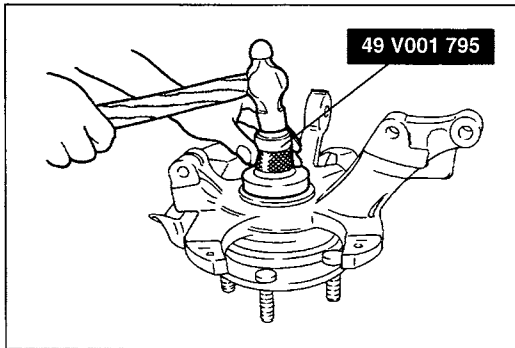

Oil seal

1. Using the **SST** and a hammer, tap a new oil seal in evenly until the **SST** contacts the steering knuckle.
2. Coat the lip of the oil seal with grease.

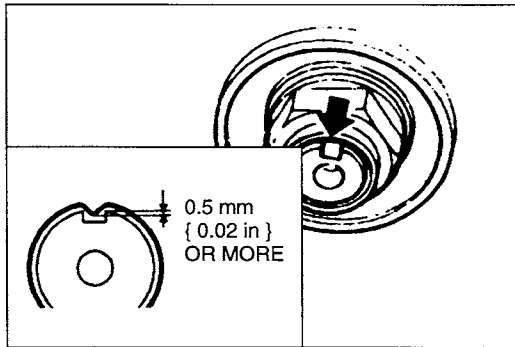

Locknut

Install a new locknut and stake it as shown.

Tightening torque

Front: 236—318 N·m



{ 24.0—32.5 kgf·m , 174—235 ft·lbf }

Rear: 177—235 N·m

{ 18.0—24.0 kgf·m , 131—173 ft·lbf }

REAR AXLE

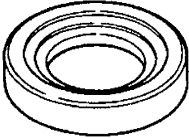
PREPARATION
SST

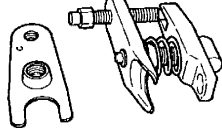
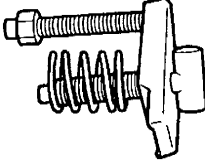
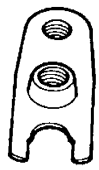
<p>49 B026 103</p> <p>Installer, sensor rotor</p> 	<p>For installation of ABS sensor rotor</p>	<p>49 0259 770B</p> <p>Wrench, flare nut</p> 	<p>For removal of brake pipe</p>
<p>49 T028 3A0</p> <p>Puller set, ball joint</p> 	<p>For removal of hub bolt</p>	<p>49 T028 303</p> <p>Body (Part of 49 T028 3A0)</p> 	<p>For removal of hub bolt</p>
<p>49 T028 304</p> <p>Attachment (Part of 49 T028 3A0)</p> 	<p>For removal of hub bolt</p>	<p>—</p>	<p>—</p>

M

WHEEL HUB, HUB SPINDLE

Preinspection

Wheel bearing play

Refer to page M-4

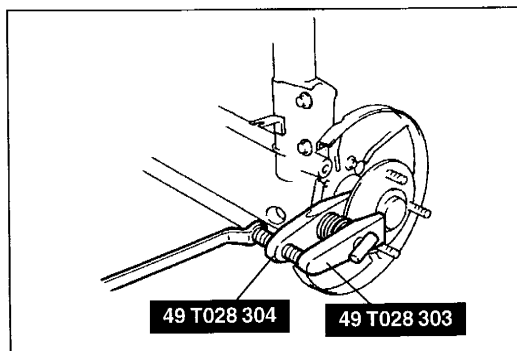

On-vehicle service

Hub bolt replacement

1. Remove the hub bolt by using the SSTs.

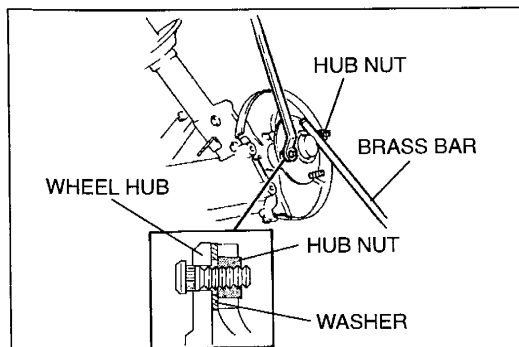

2. As shown in the figure, install the hub bolt into the wheel hub and set a washer and hub nut in the hub bolt.
3. Tighten the hub nut while holding the wheel hub by using the brass bar.

Removal / Inspection / Installation Disc brake model

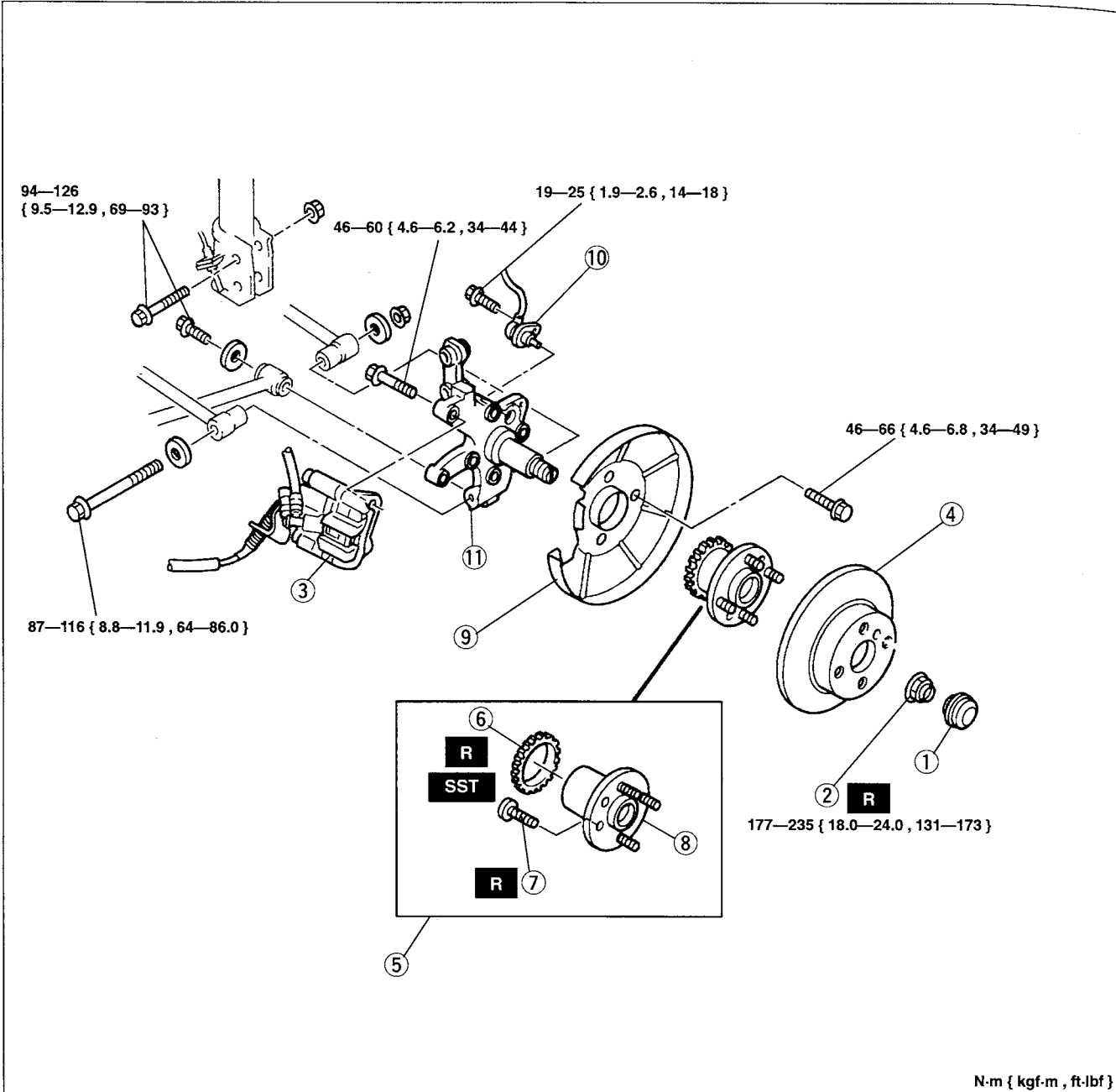

- | | |
|--|---|
| <p>1. Hub cap</p> <p>2. Locknut
Removal Note page M-6
Installation Note page M-8</p> <p>3. Brake caliper assembly
Service section P</p> <p>4. Disc plate
Service section P</p> <p>5. Wheel hub assembly
Inspect for damage
Inspect bearing for damage and rough rotation</p> | <p>6. ABS sensor rotor
Removal Note page M-11
Installation Note page M-11
Service section P</p> <p>7. Hub bolt
Removal Note page M- 7
Installation Note page M- 7</p> <p>8. Wheel hub</p> <p>9. Dust cover
Inspect for damage and cracks</p> <p>10. ABS wheel-speed sensor
Service section P</p> <p>11. Hub spindle
Inspect for damage and cracks</p> |
|--|---|

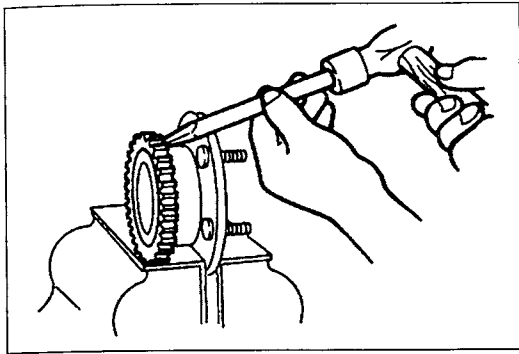

Removal note
ABS sensor rotor

Note

- The sensor rotor does not need to be removed unless you are replacing it.

Remove the sensor rotor by using a chisel.

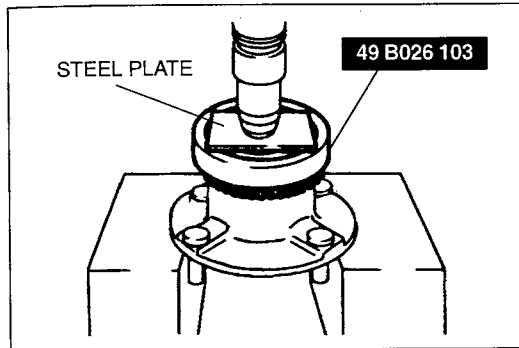

Installation note
ABS sensor rotor

1. Install a new rear ABS sensor rotor onto the wheel hub.

Note

- The ABS sensor rotor can be installed in either direction.

2. Using a steel plate and the **SST**, press the rotor on until it is flush with the wheel hub.



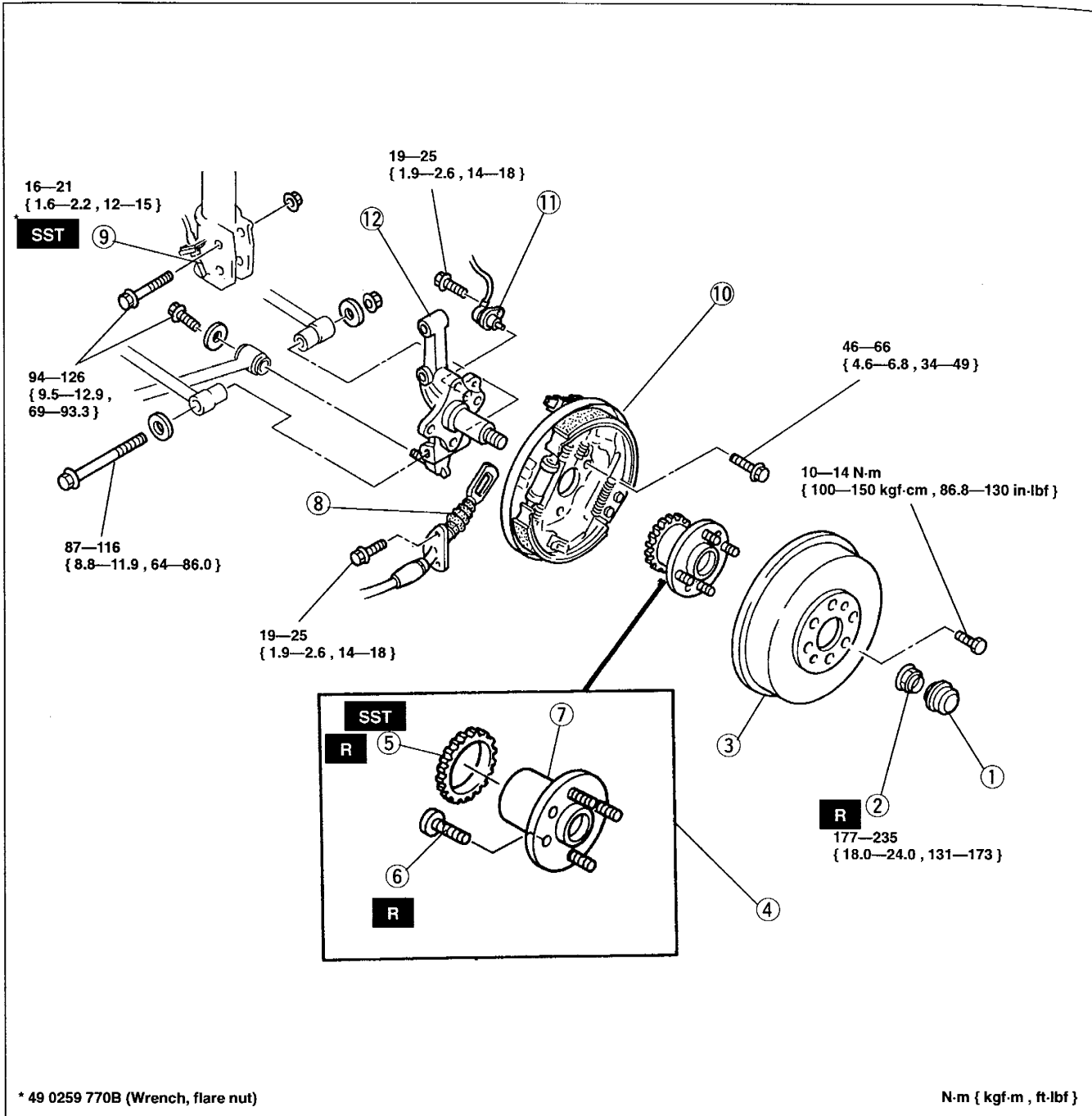

Drum brake model

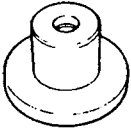
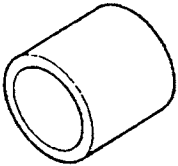

- | | |
|---|--|
| <p>1. Hub cap</p> <p>2. Locknut
Removal Note page M- 6
Installation Note page M- 8</p> <p>3. Brake drum
Service section P</p> <p>4. Wheel hub assembly
Inspect for damage
Inspect bearing for damage
and rough rotation</p> <p>5. ABS sensor rotor
Removal Note page M-11
Installation Note page M-11</p> | <p>6. Hub bolt
Removal Note page M-7
Installation Note page M-7</p> <p>7. Wheel hub</p> <p>8. Parking brake cable</p> <p>9. Brake pipe
Service section P</p> <p>10. Rear brake assembly
Service section P</p> <p>11. ABS wheel-speed sensor
Service section P</p> <p>12. Hub spindle
Inspect for damage and cracks</p> |
|---|--|

DRIVE SHAFT

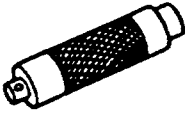
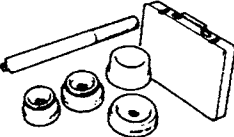
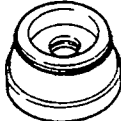
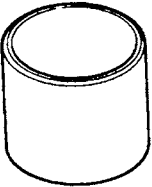
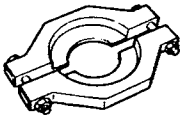
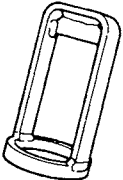
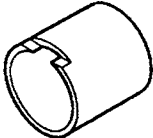
PREPARATION
SST

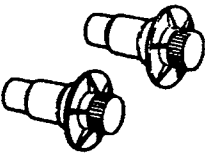
<p>49 F026 102</p> <p>Installer, bearing</p>		<p>For removal of bearing</p>	<p>49 W027 003</p> <p>Installer, bearing</p>	 <p>For installation of dust seal</p>
<p>49 G030 795</p> <p>Installer oil seal</p>		<p>For installation of dust seal</p>	<p>49 G030 797</p> <p>Handle (Part of 49 G030 795)</p>	 <p>For installation of dust seal</p>
<p>49 F027 0A1</p> <p>Installer set, bearing</p>		<p>For installation of bearing</p>	<p>49 F027 005</p> <p>Attachment 62 (Part of 49 F027 0A1)</p>	 <p>For installation of bearing</p>
<p>49 B025 004</p> <p>Installer, dust, boot</p>		<p>For installation of dust seal</p>	<p>49 H027 002</p> <p>Remover, bearing</p>	 <p>For removal of joint shaft bearing</p>
<p>49 B025 003</p> <p>Installer, sensor rotor</p>		<p>For installation of sensor rotor</p>	<p>49 H034 201</p> <p>Support block</p>	 <p>For removal of bearing</p>
<p>49 B025 006</p> <p>Installer, sensor rotor</p>		<p>For installation of sensor rotor</p>	<p>49 G030 455</p> <p>Holder, diff. side gear</p>	 <p>For holding side gear</p>

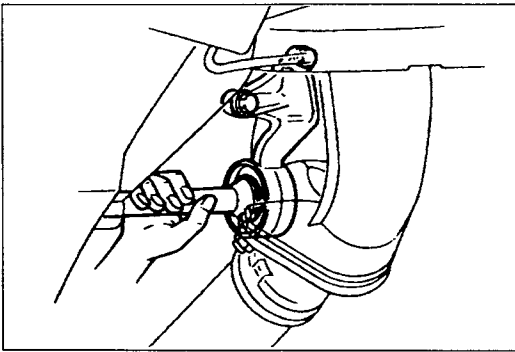

JOINT SHAFT Preinspection Joint shaft

1. Verify that the joint shaft is not twisted or cracked. Replace it if necessary.
2. Turn the joint shaft by hand and verify that the bearing rotates smoothly and freely. Replace it if necessary.

Removal / Installation

- After installation, fill the transaxle with the specified amount and type of ATF, and inspect for oil leakage. (Refer to section J, K.)

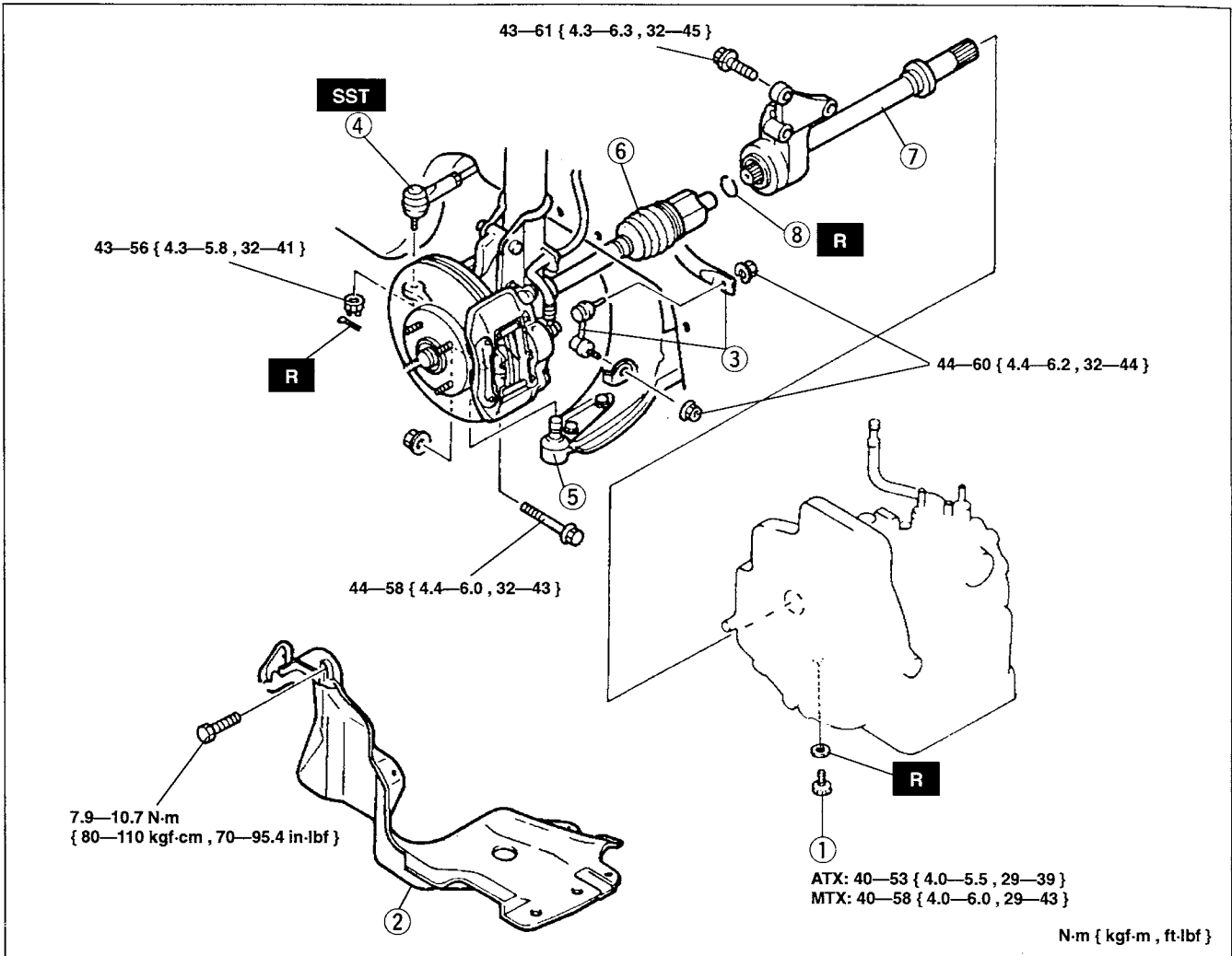

1. Drain plug
2. Splash shield(s)
3. Stabilizer control link
4. Tie-rod end
Service section N
5. Lower arm ball joint
6. Drive shaft and axle assembly
Removal Note page M-15
Installation Note page M-15

7. Joint shaft
Removal Note page M-15
Installation Note page M-15
Disassembly / Inspection /
Assembly page M-16
8. Clip
Installation Note page M-15

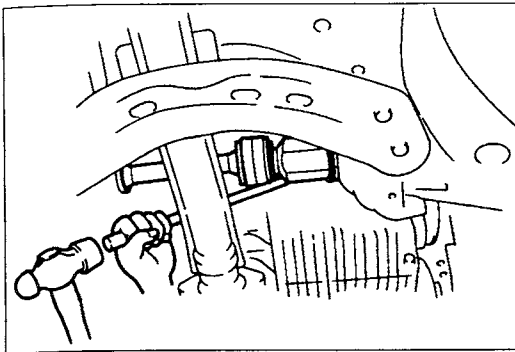

Removal note

Drive shaft and axle assembly

Separate the right-side drive shaft from the joint shaft by hammering on a brass or copper bar inserted between them.

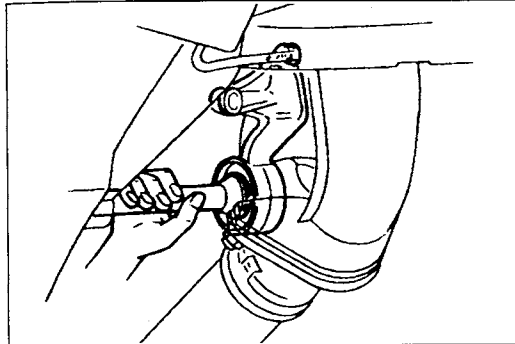

Joint shaft

Pull the joint shaft straight out.

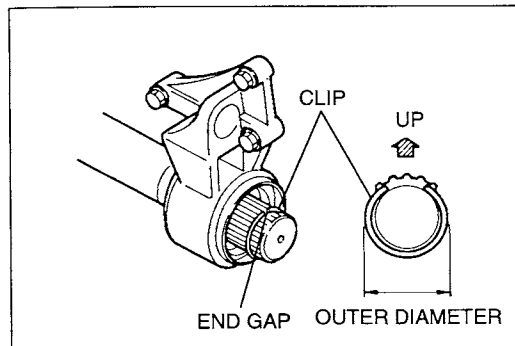

Installation note

Clip

1. Install a new clip so that the opening is facing upwards.
2. Measure the outer diameter of the clip after installing, and replace the clip if it exceeds the specification.

Outer diameter: 30 mm { 1.181 in } max.

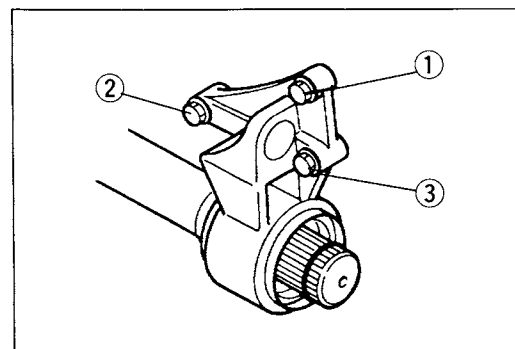

Joint shaft

Tighten the bolts in the order shown.

Tightening torque:

43—61 N·m { 4.3—6.3 kgf·m , 32—45 ft·lbf }

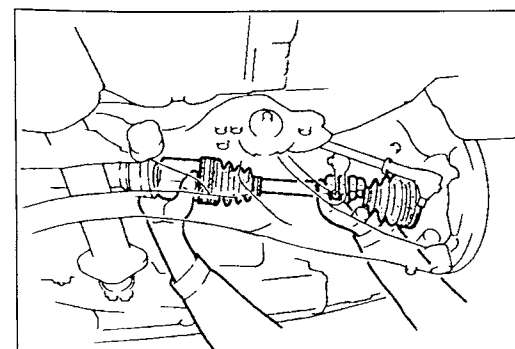

Drive shaft and axle assembly

1. Push the drive shaft onto the joint shaft.
2. After installation, pull the front hub outward to verify that the drive shaft is securely held by the clip.

Disassembly / Inspection / Assembly

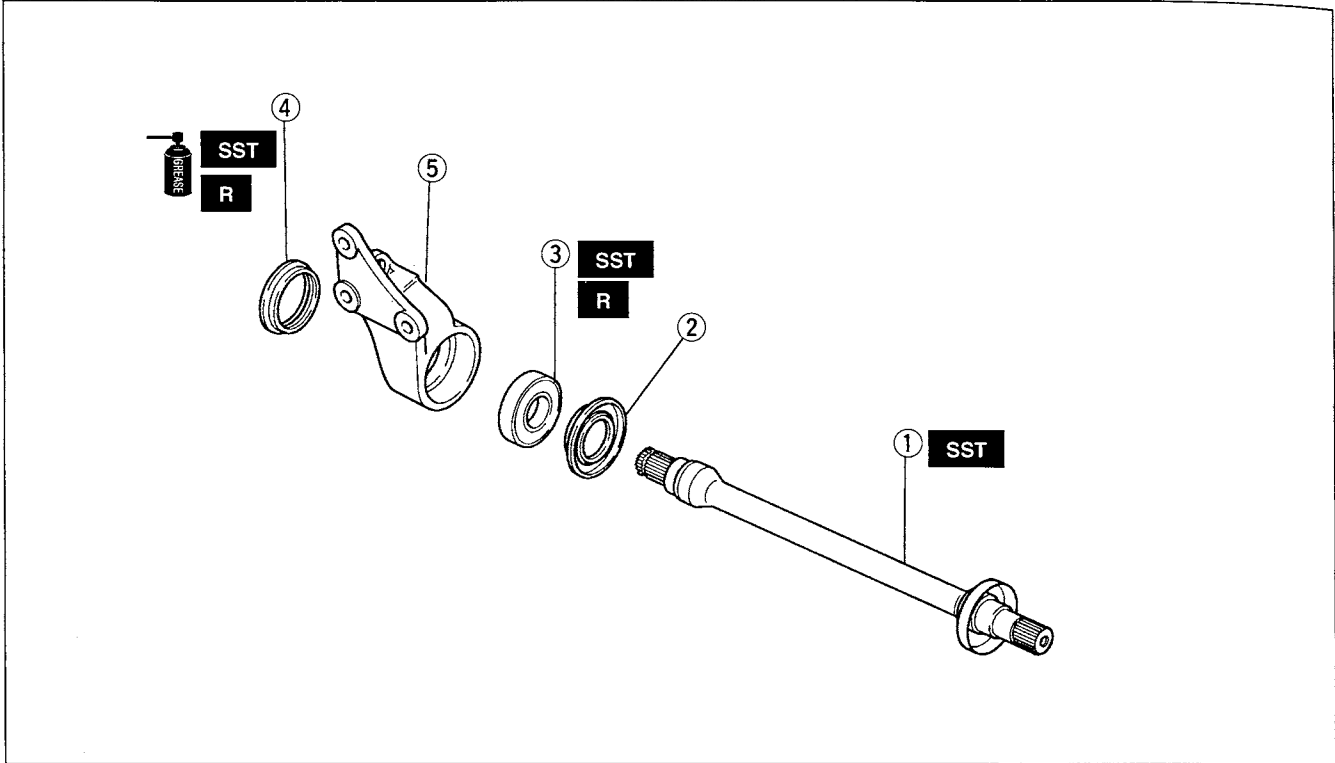

- | | |
|--|---|
| <p>1. Joint shaft
Inspect splines for damage and wear
Disassembly Note below
Assembly Note page M-17</p> <p>2. Dust seal (differential side)
Assembly Note page M-17</p> | <p>3. Bearing
Disassembly Note below
Assembly Note page M-17</p> <p>4. Dust seal (drive shaft side)
Assembly Note page M-17</p> <p>5. Bracket</p> |
|--|---|

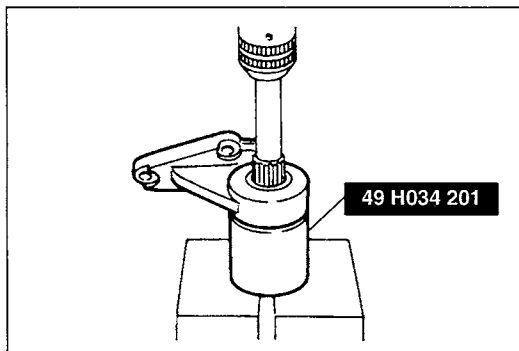

Disassembly note Joint shaft

While holding the joint shaft, press it out by using the SST.

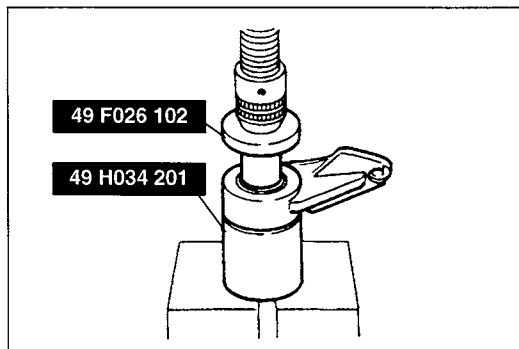

Bearing

If the bearing remains on the bracket, press out the bearing by using the SSTs.

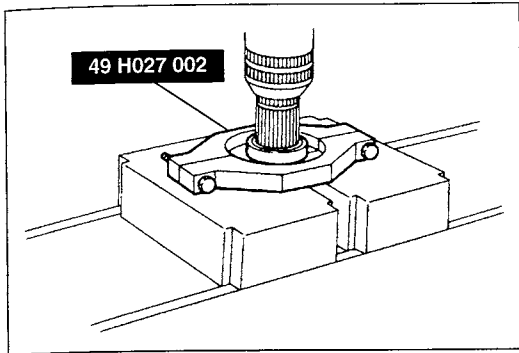

If the bearing remains on the shaft, while holding the joint shaft, press it out by using the **SST**.

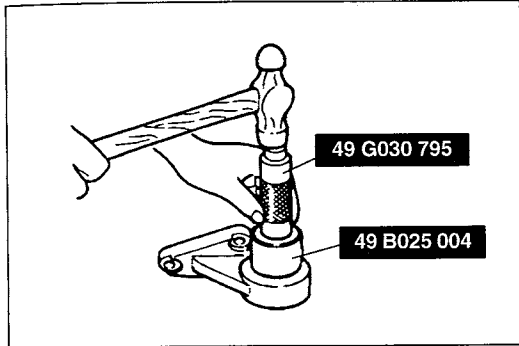

Assembly note
Dust seal (drive shaft side)

Tap in the new drive shaft side dust seal by using the **SSTs**.

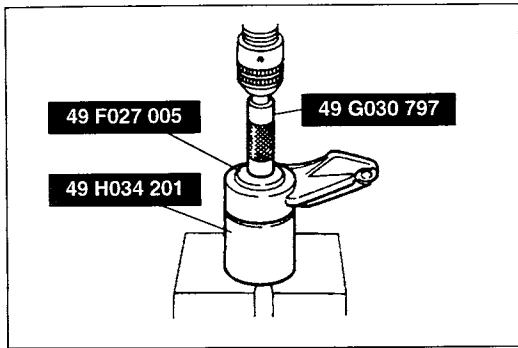

Bearing

Press in the new bearing by using the **SSTs**.

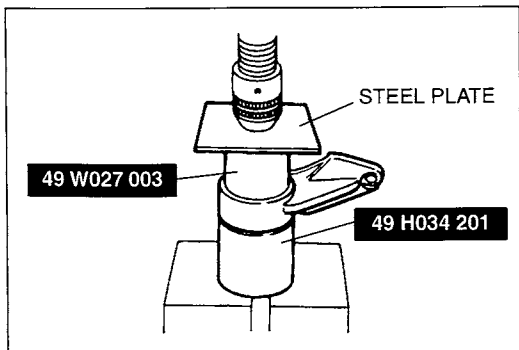

Dust seal (differential side)

Press in the new differential side dust seal by using a steel plate and the **SSTs**.

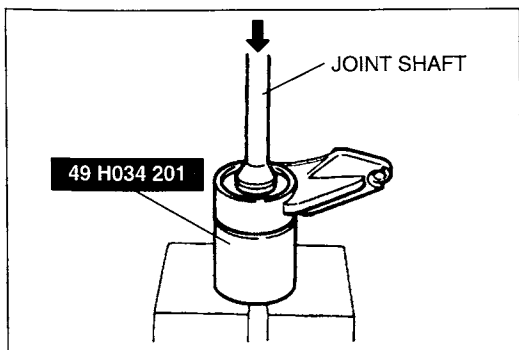

Joint shaft

Press in the joint shaft by using the **SST**.

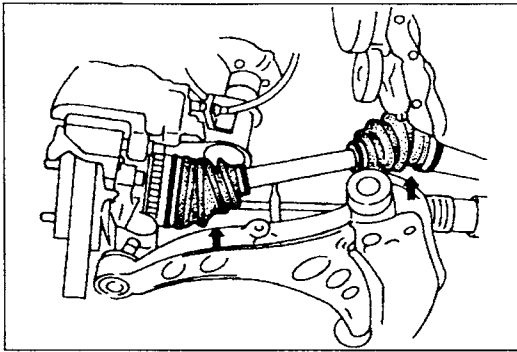

DRIVE SHAFT Preinspection Drive shaft

1. Check the drive shaft dust boot for cracks, damage, leaking grease, and loose boot bands.
2. Check the drive shaft for bending, cracks, and wear of joints or splines.
3. Repair or replace the drive shaft if necessary.

Removal / Installation

- After installation, fill the transaxle with the specified amount and type of oil, and inspect for oil leakage. (Refer to section J, K.)

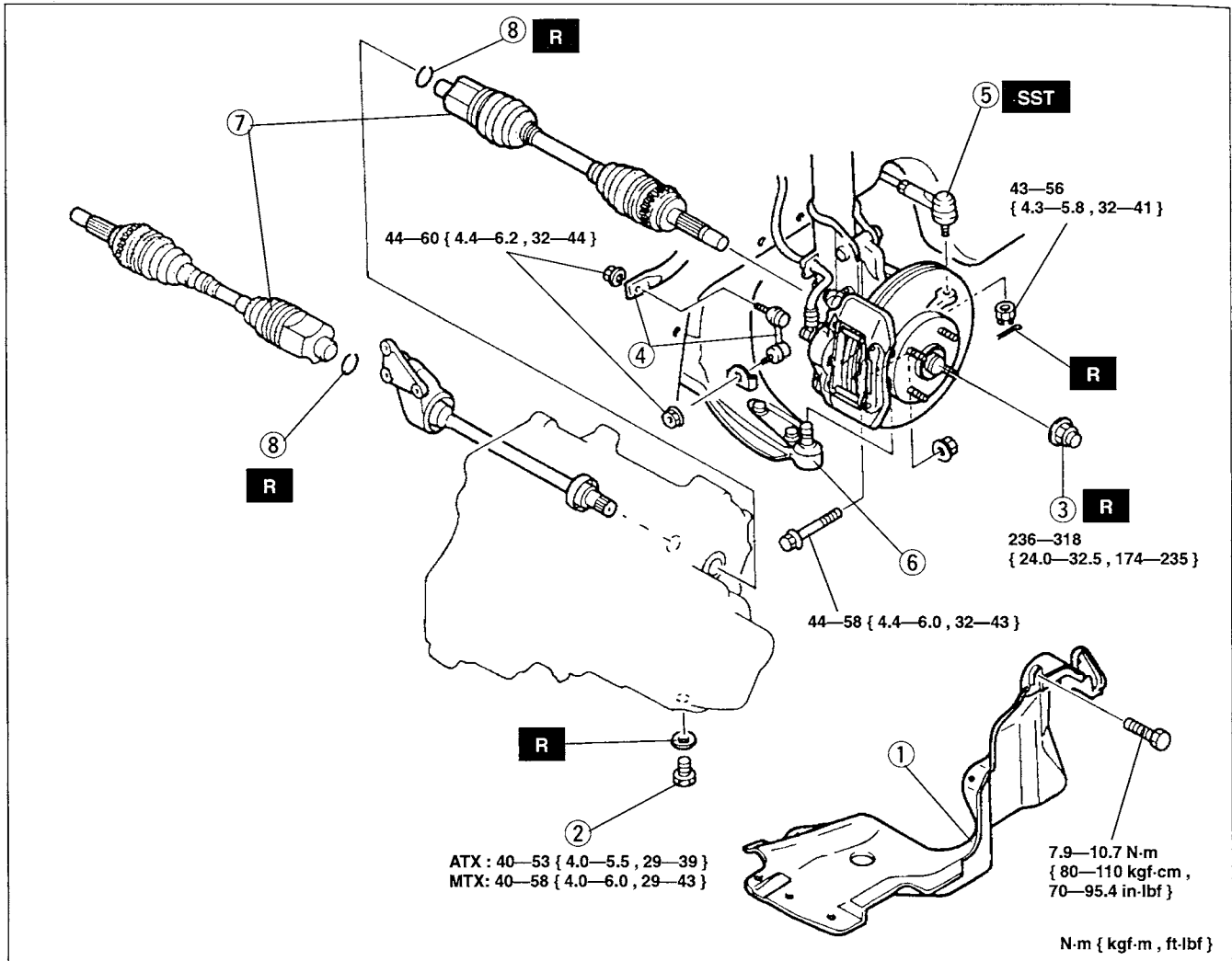

- | | |
|--|--|
| <ol style="list-style-type: none"> 1. Splash shield 2. Drain plug 3. Locknut Removal Note page M-6 Installation Note page M-8 4. Stabilizer control link Service section R 5. Tie-rod end Service section N | <ol style="list-style-type: none"> 6. Lower arm ball joint Service section R 7. Drive shaft Removal Note page M-19 Installation Note page M-19 Disassembly / Inspection /
Assembly page M-20 8. Clip Installation Note page M-15 |
|--|--|

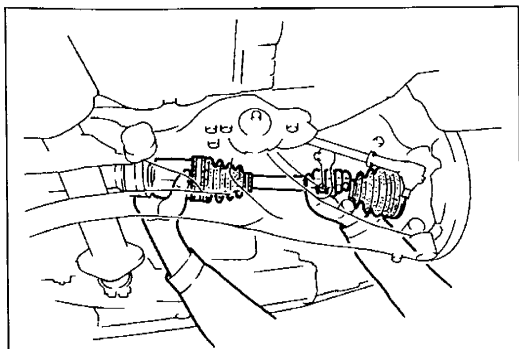
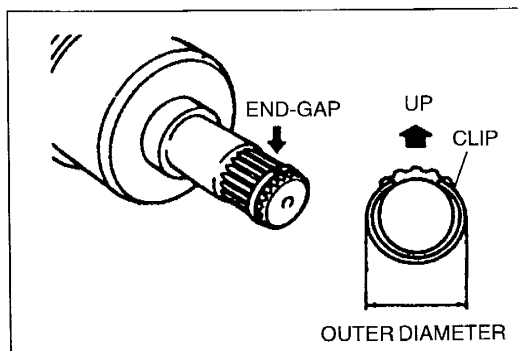
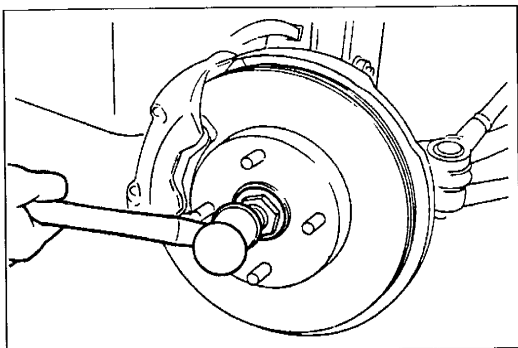
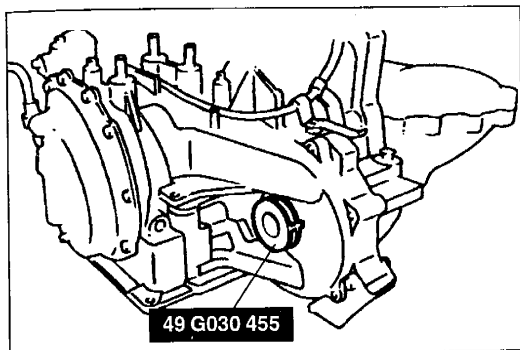
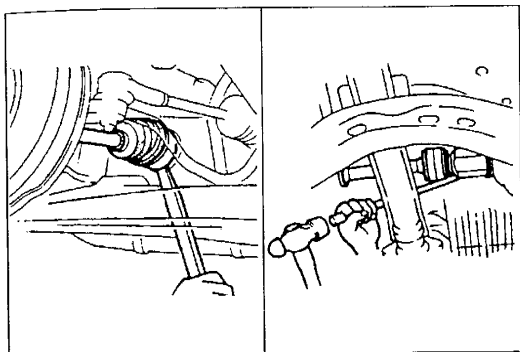

Removal note Drive shaft

Caution

- The sharp edges of the drive shaft snap ring can slice or puncture the oil seal. Be careful when removing the drive shaft from the transaxle.

1. Separate the left-side drive shaft from the transaxle by prying with a bar inserted between the outer ring and the transaxle, as shown in the figure.
2. Separate the right-side drive shaft from the joint shaft by hammering on a brass or copper bar inserted between them.
3. Install the **SST** into the transaxle to hold the side gears. (except F25M-R).

Note

- If the drive shaft will not come out of the front wheel hub easily, install an already discarded nut onto the drive shaft so that the nut is flush with the end of the drive shaft. Tap the nut with a copper hammer to loosen the drive shaft from the front wheel hub.

Installation note Drive shaft

1. Install a new clip onto the drive shaft.
2. Measure the outer diameter of the clip after installing, and replace the clip if it exceeds the specification.

Outer diameter

- BP engine MTX: 30 mm { 1.181 in }
- Other models: 27 mm { 1.063 in }

Caution

- The sharp edges of the drive shaft snap ring can slice or puncture the oil seal. Be careful when installing the drive shaft to the transaxle.
3. Push the drive shaft into the transaxle (left side) or joint shaft (right side).
 4. After installation, pull the front hub outward to confirm that the drive shaft is securely held by the clip.

Disassembly / Inspection / Assembly

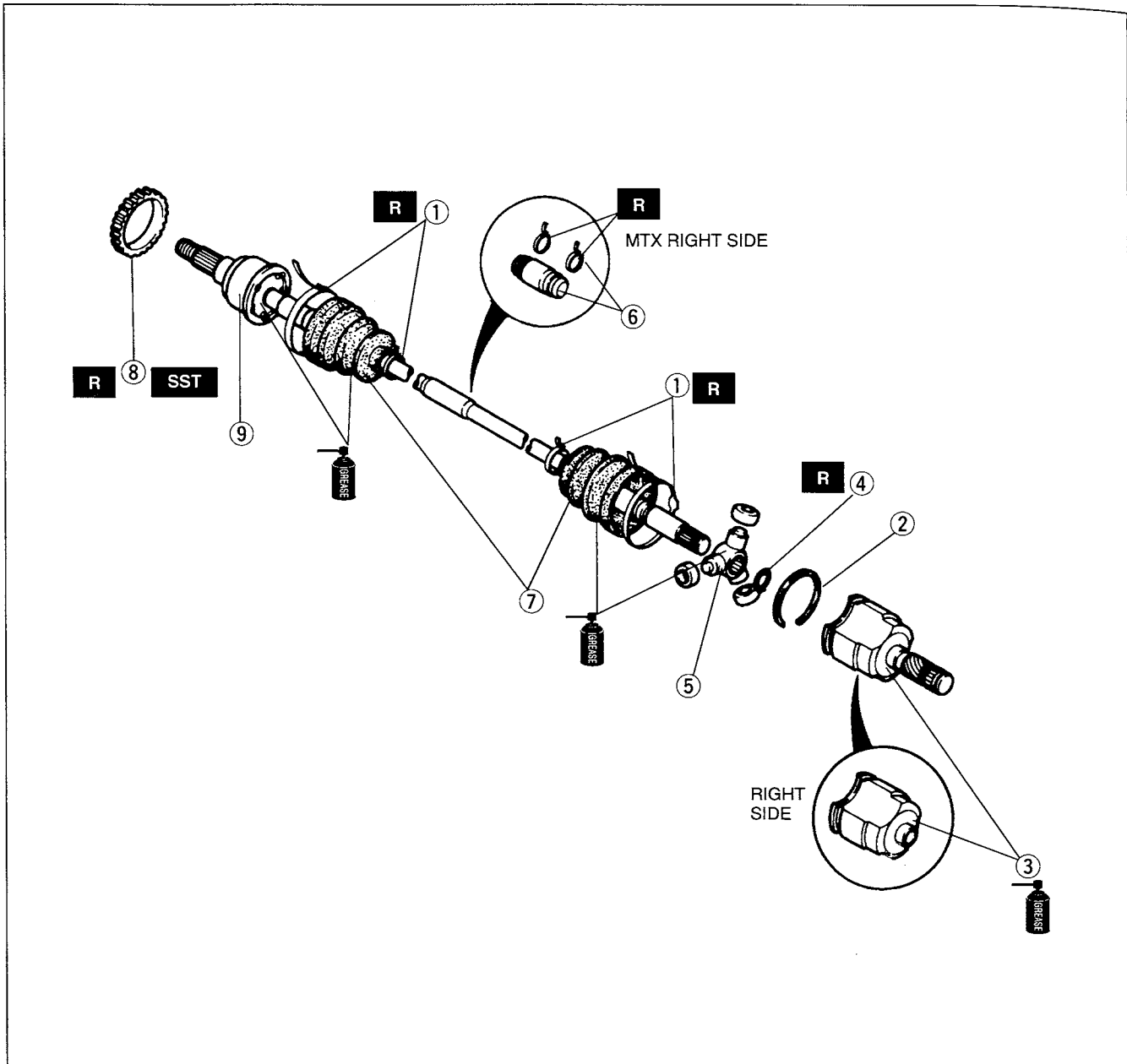

- | | |
|--|-----------|
| 1. Boot band | |
| Disassembly Note | page M-21 |
| Assembly Note | page M-23 |
| 2. Stopper ring | |
| 3. Outer ring | |
| Disassembly Note | page M-21 |
| Inspect inside bore for wear, corrosion, and scoring | |
| Assembly Note | page M-23 |
| 4. Snap ring | |
| Disassembly Note | page M-21 |
| Assembly Note | page M-23 |
| 5. Tripod joint | |
| Disassembly Note | page M-21 |
| Inspect for damage and wear | |
| Assembly Note | page M-23 |
| 6. Dynamic damper | |
| Assembly Note | page M-22 |
| 7. Boot | |
| Disassembly Note | page M-21 |
| Inspect for damage | |
| Assembly Note | page M-22 |
| 8. ABS sensor rotor | |
| Disassembly Note | page M-22 |
| Assembly Note | page M-22 |
| 9. Shaft and ball joint assembly | |
| Inspect splines for damage and wear | |
| Inspect wheel-side joint for excessive play and rough rotation | |

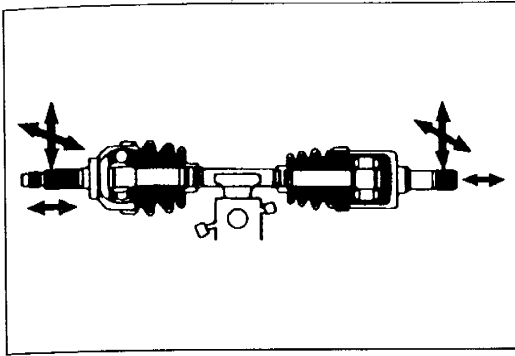

Preinspection Drive shaft assembly

1. Move the joint the directions shown to check for excessive play and rough rotation. Replace the drive shaft if necessary.
2. Inspect boot for cracks, damage, and grease leakage. Replace it if necessary.

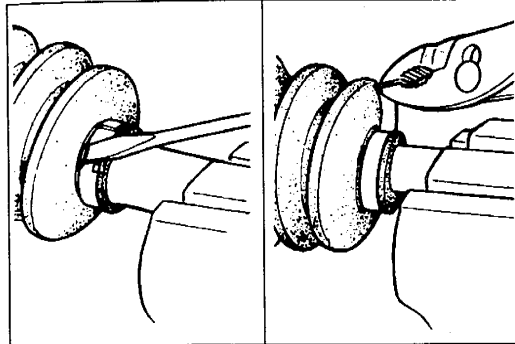

Disassembly note Boot band

Note

- The boot band does not need to be removed unless you are replacing it.

1. Pry up the locking clips of the boot band.
2. Remove the boot band by using pliers.

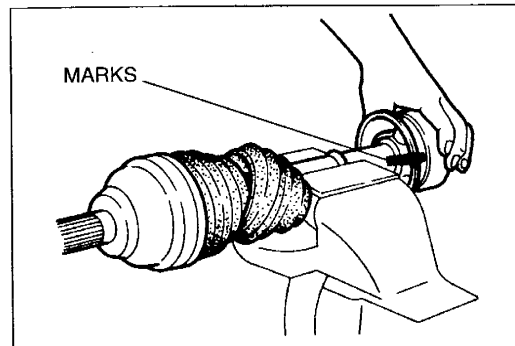

Outer ring

1. Mark the outer ring and the shaft for proper reassembly.
2. Remove the outer ring, being careful to keep the free rings from dropping.

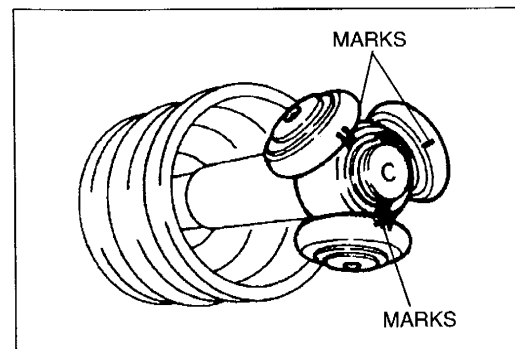

Snap ring/Tripod joint

1. Mark the shaft, tripod joint, and free rings for proper reassembly.
2. Remove the snap ring by using snap-ring pliers.
3. Remove the tripod joint from the shaft by using a bar and a hammer.

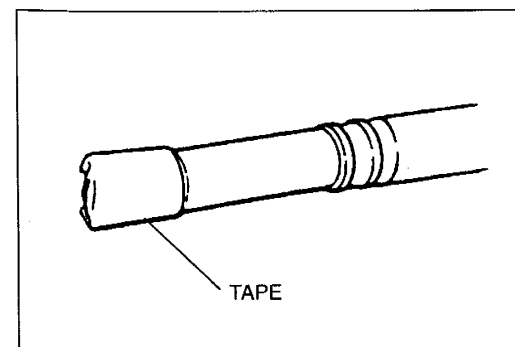

Boot

Note

- The wheel-side boot does not need to be removed unless you are replacing it.

Wrap the splines of the shaft with tape to prevent damaging the boot.

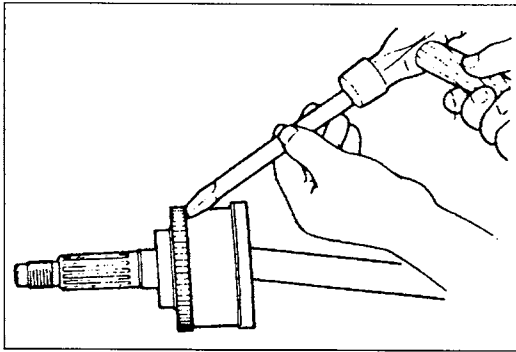

ABS sensor rotor

Note

- The sensor rotor does not need to be removed unless you are replacing it.

Tap the ABS sensor rotor off of the drive shaft by using a chisel.

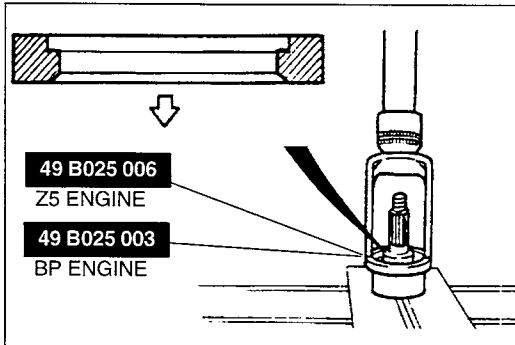

Assembly note

ABS sensor rotor

Set a new ABS sensor rotor on the drive shaft in the direction shown, and press it onto the shaft assembly by using the SST.

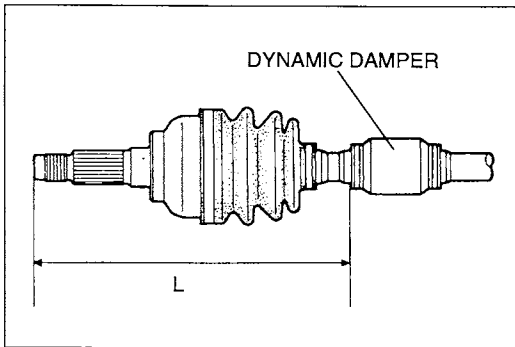

Dynamic damper

1. Install the dynamic damper as shown in the figure.

Length L

Z5 engine: 292—298 mm { 11.5—11.7 in }

BP engine: 247—253 mm { 9.73—9.96 in }

2. Install the new boot band onto the dynamic damper.

Standard length: 292—298 mm { 11.5—11.7 in }

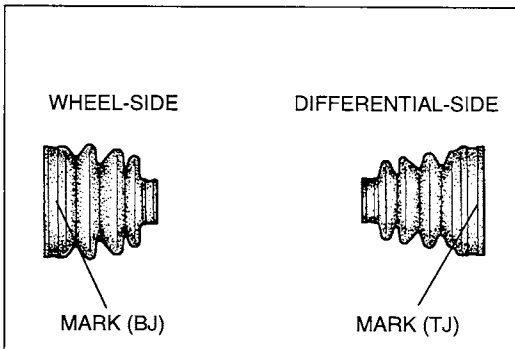

Boot

Note

- The initials TJ and BJ are stamped on the wheel-side and differential-side boots respectively.

1. Wrap the splines of the differential-side shaft, and install the wheel-side and differential-side boots.

2. Fill the wheel side boot with the grease supplied in the boot kit.

Grease amount

Z5 engine: 60—90 g { 2.1—3.2 oz }

BP engine: 80—100 g { 2.8—3.5 oz }

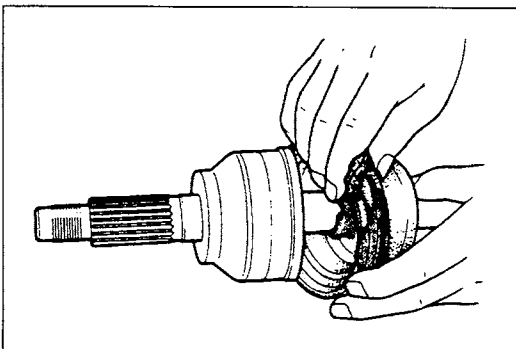

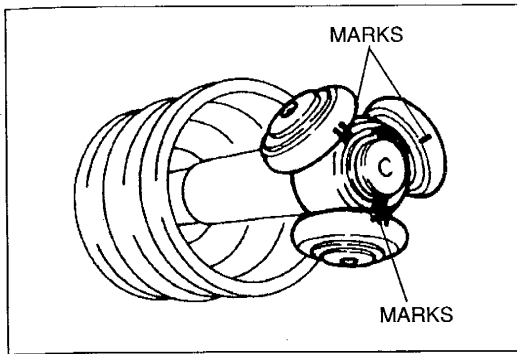

Tripod joint/Outer ring/Snap ring

1. Fill the outer ring and differential-side boot with the grease supplied in the boot kit.

Grease amount

Z5 engine: 115—135 g { 4.06—4.77 oz }

BP engine: 135—155 g { 4.77—5.47 oz }

2. Align the marks and install the tripod joint and free rings.
3. Install a new snap ring by using snap-ring pliers.
4. While supporting the free rings, install the outer ring.

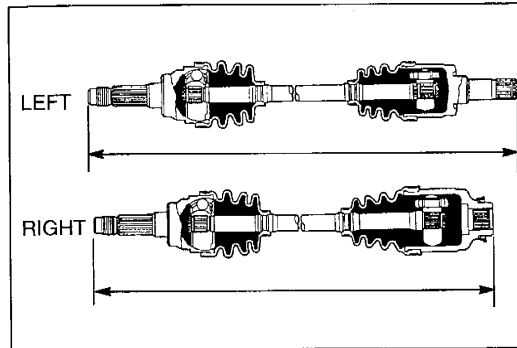

Boot band

1. Verify that the boots are not dented or twisted.
2. Set the drive shaft to the standard length.

Standard length

mm { in }

		Right	Left
Z5 engine	ATX	595.5—605.5 { 23.44—23.84 }	649.5—659.5 { 25.57—25.96 }
	MTX		653.5—663.5 { 25.73—26.12 }
BP engine	ATX	640.5—650.5 { 25.22—25.61 }	647.3—657.3 { 25.48—25.88 }
	MTX		633.4—643.4 { 24.94—25.33 }

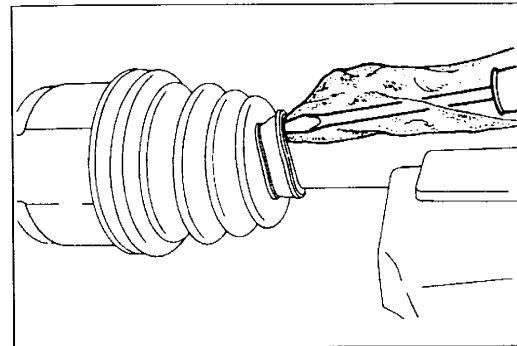

3. Release any trapped air from inside the boot by using a rag-covered screwdriver.
4. Verify that the drive shaft length is within the standard.
5. If the drive shaft length is not within the standard, return to step 1.

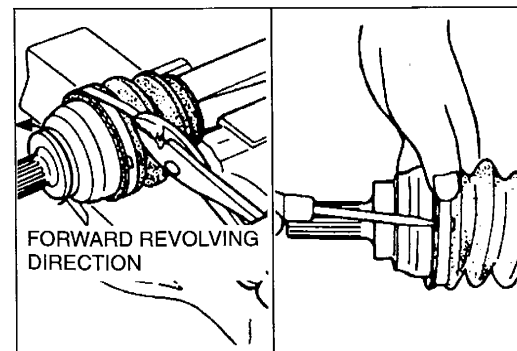

6. Fold the new bands back by pulling on the ends with pliers, so that the ends of the bands are pointing opposite the forward revolving direction of the shaft.
7. Lock the ends of the bands by bending the locking clips.

Before beginning any service procedure, refer to section T1 of this manual for air bag system service warnings.

STEERING SYSTEM

- OUTLINE N- 2
- SPECIFICATIONS N- 2
- GENERAL PROCEDURES N- 2
- ENGINE SPEED SENSING POWER STEERING .. N- 3
- PREPARATION N- 3
- AIR BLEEDING N- 5
- POWER STEERING FLUID N- 6
- STEERING WHEEL AND COLUMN N- 8
- STEERING GEAR AND LINKAGE N-12
- POWER STEERING OIL PUMP N-24

OUTLINE

SPECIFICATIONS

Item		Specification
Steering wheel	Outer diameter mm { in }	380 { 15.0 } or 370 { 14.6 }
	Lock-to-lock turns	3.07
Steering gear	Type	Rack and pinion
	Rack stroke mm { in }	138 { 5.43 }
Steering column and shaft	Shaft type	Collapsible
Power assist system		Engine speed sensing
Power steering fluid	Type	Dexron®II or M-III
	Fluid capacity L { US qt , Imp qt }	1.3 { 1.4 , 1.1 }

GENERAL PROCEDURES

Removal / Installation, Disassembly / Assembly

- The numbers in the structural view indicate the removal and disassembly order. For installation and assembly, follow the reverse order.

Wheels and Tires

- The removal and installation procedures for the wheels and tires are not mentioned in this section. If you must remove a wheel, retighten it to **89—127 N·m { 9.0—13.0 kgf·m , 66—94 ft·lbf }**.

Suspension

- Tighten any part of the suspension that uses rubber bushings only after the vehicle has been lowered and unloaded.

Power Steering Components

- If a power steering fluid line(s) has been disconnected anytime during the procedure, add ATF (Dexron®II or M-III), bleed the fluid line(s), and inspect for leakage after the procedure has been completed.







Undercover

- The removal and installation procedures for the undercover are not mentioned in this section.

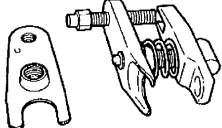
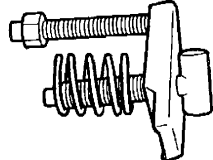
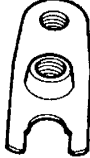
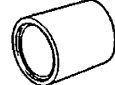

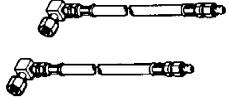

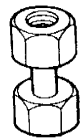
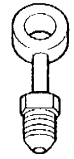
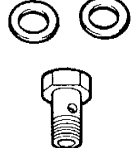

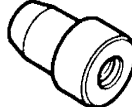
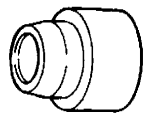

ENGINE SPEED SENSING POWER STEERING

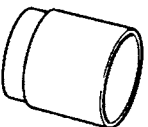
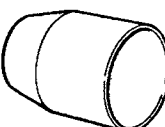
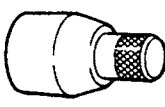
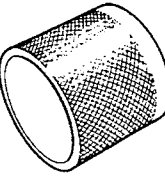
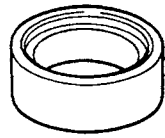

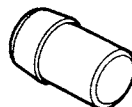



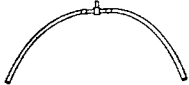

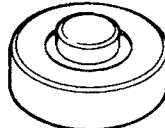
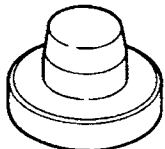
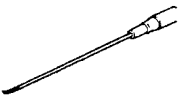
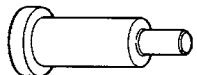
PREPARATION

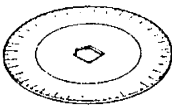
SST

<p>49 T028 3A0</p> <p>Puller set, ball joint</p> 	<p>For removal of ball joint</p>	<p>49 T028 303</p> <p>Body (Part of 49 T028 3A0)</p> 	<p>For removal of ball joint</p>
<p>49 T028 304</p> <p>Attachment (Part of 49 T028 3A0)</p> 	<p>For removal of ball joint</p>	<p>49 F034 201</p> <p>Installer, dust boot</p> 	<p>For installation of tie-rod end boot</p>
<p>49 1232 670A</p> <p>Gauge set, power steering</p> 	<p>For inspection of power steering fluid pressure</p>	<p>49 1232 672</p> <p>Gauge (Part of 49 1232 670A)</p> 	<p>For inspection of power steering fluid pressure</p>
<p>49 1232 673</p> <p>Body, valve (Part of 49 1232 670A)</p> 	<p>For inspection of power steering fluid pressure</p>	<p>49 H002 671</p> <p>Adapter, power steering gauge</p> 	<p>For inspection of power steering fluid pressure</p>
<p>49 G032 3A4</p> <p>Adapter, power steering gauge</p> 	<p>For inspection of power steering fluid pressure</p>	<p>49 G032 351</p> <p>Adapter (Part of 49 G032 3A4)</p> 	<p>For inspection of power steering pressure</p>
<p>49 G032 352</p> <p>Adapter (Part of 49 G032 3A4)</p> 	<p>For inspection of power steering fluid pressure</p>	<p>49 G032 353</p> <p>Bolt (Part of 49 G032 3A4)</p> 	<p>For inspection of power steering fluid pressure</p>
<p>49 B032 307</p> <p>Wrench, outer box</p> 	<p>For removal and installation of outer box</p>	<p>49 B032 308</p> <p>Remover body, rod seal</p> 	<p>For removal of oil seal</p>
<p>49 B032 309</p> <p>Installer body, pinion seal</p> 	<p>For installation of pinion seal</p>	<p>49 B032 310</p> <p>Protector, pinion seal</p> 	<p>For installation of pinion seal</p>

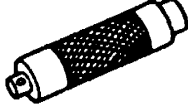
N

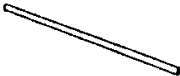
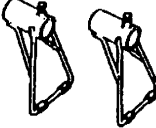
<p>49 B032 311</p> <p>Protector, slipper seal</p>		<p>For installation of pinion shaft</p>	<p>49 B032 312</p> <p>Protector, slipper seal</p>		<p>For installation of seal ring</p>
<p>49 B032 313</p> <p>Protector, outer box</p>		<p>For installation of outer box</p>	<p>49 B032 314</p> <p>Slipper seal former</p>		<p>For form of seal ring</p>
<p>49 B032 316</p> <p>Support block, plug</p>		<p>For removal of oil seal & bearing</p>	<p>49 B032 317</p> <p>Remover, bearing & oil seal</p>		<p>For removal of oil seal & bearing</p>
<p>49 B032 318</p> <p>Guide, rod seal</p>		<p>For installation of inner guide & oil seal</p>	<p>49 B032 319</p> <p>Protector body, rod seal</p>		<p>For installation of inner guide & oil seal</p>
<p>49 B032 320</p> <p>Wrench</p>		<p>For removal and installation of locknut</p>	<p>49 B032 321</p> <p>Adapter</p>		<p>For check of cylinder air-tightness</p>
<p>49 G032 317</p> <p>Hose</p>		<p>For check of cylinder air-tightness</p>	<p>49 F032 303</p> <p>Handle</p>		<p>For removal of oil seal</p>
<p>49 B032 330</p> <p>Installer, bearing</p>		<p>For installation of plug bearing</p>	<p>49 B032 331</p> <p>Installer, oil seal</p>		<p>For installation of oil seal</p>
<p>49 B032 332</p> <p>Remover, oil seal</p>		<p>For removal of pinion oil seal</p>	<p>49 B032 305</p> <p>Holder, power steering pump</p>		<p>For disassembly / assembly of power steering oil pump</p>

<p>49 D032 316 Protractor</p> 	<p>For installation of adjusting cover</p>	<p>49 0180 510B Attachment, preload</p> 	<p>For inspection of pinion preload</p>
<p>49 H032 321A Hex-head wrench</p> 	<p>For removal and installation of adjusting cover</p>	<p>49 H032 301 Wrench</p> 	<p>For removal tie rod</p>
<p>49 G030 797 Handle</p> 	<p>For installation of pinion seal</p>	<p>49 G017 5A0 Support, engine</p> 	<p>For support of engine</p>
<p>49 G017 501 Bar (Part of 49 G017 5A0)</p> 	<p>For support of engine</p>	<p>49 G017 502 Support (Part of 49 G017 5A0)</p> 	<p>For support of engine</p>
<p>49 G017 503 Hook (Part of 49 G017 5A0)</p> 	<p>For support of engine</p>	<p>—</p>	<p>—</p>

N

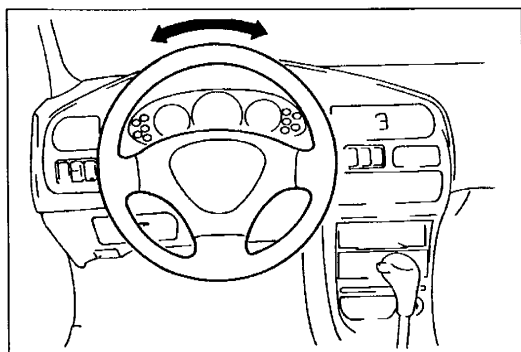

AIR BLEEDING

1. Check the fluid level.
2. Jack up the vehicle and support it on safety stands.
3. Turn the steering wheel fully left and right several times with the engine not running.
4. Recheck the fluid level. If it has dropped, add fluid.
5. Repeat steps 3 and 4 until the fluid level stabilizes.
6. Lower the vehicle.
7. Start the engine and let it idle.
8. Turn the steering wheel fully left and right several times.
9. Verify that the fluid is not foamy and that the fluid level has not dropped.
10. Add fluid if necessary and repeat steps 8 and 9.

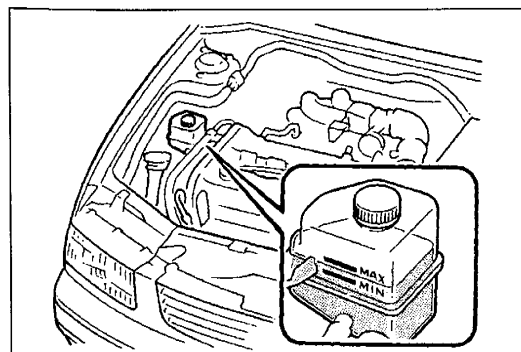

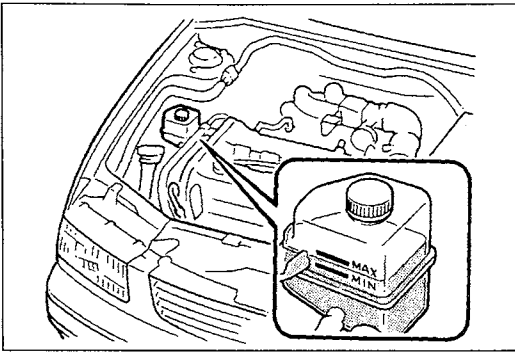

POWER STEERING FLUID

Inspection

Fluid level

Check the power steering fluid level. Add the specified power steering fluid if necessary.

Fluid specification: ATF Dexron® II or M-III

Fluid leakage

Caution

- Never hold the steering wheel to the extreme left or right for more than 5 seconds with the engine running. This could damage the power steering pump.

Start the engine and let it idle. Turn the steering wheel fully left and right to apply fluid pressure. Inspect the points shown in the figure for fluid leakage.

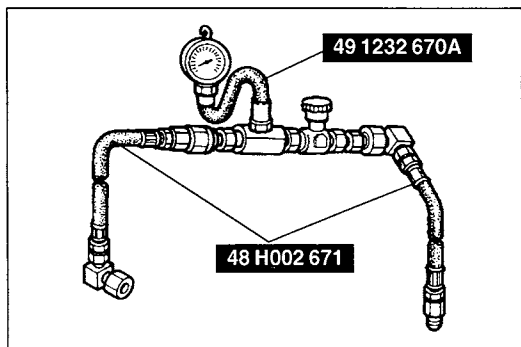
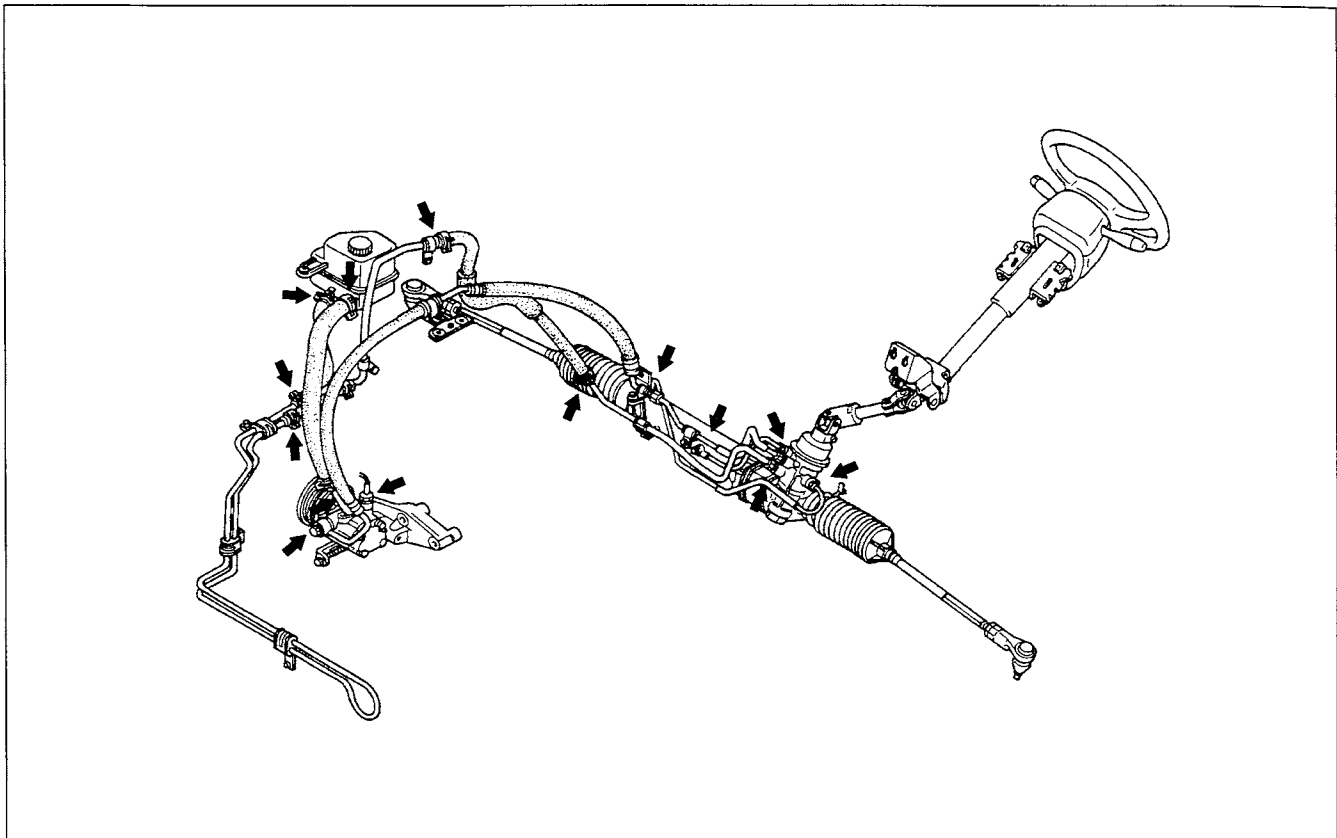

Fluid pressure

1. Assemble the SSTs as shown in the figure.

Tightening torque:

30—39 N·m { 3.0—4.0 kgf·m , 22—28 ft·lbf }

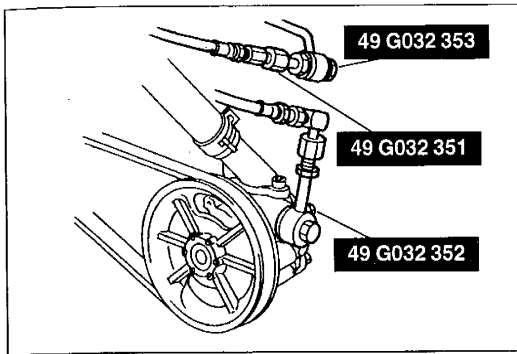

2. Mark both hose connections to ensure that the hose is reinstalled in its original position.
3. Disconnect the pressure hose from the oil pump. Attach the **SSTs** (adapters).
4. Connect the **SSTs** (gauge set) to the **SSTs** (adapters).
5. Bleed the air from the system. (Refer to page N-5.)
6. Open the gauge valve fully. Start the engine and turn the steering wheel fully left and right to raise the fluid temperature to 50—60 °C { 122—140 °F }.

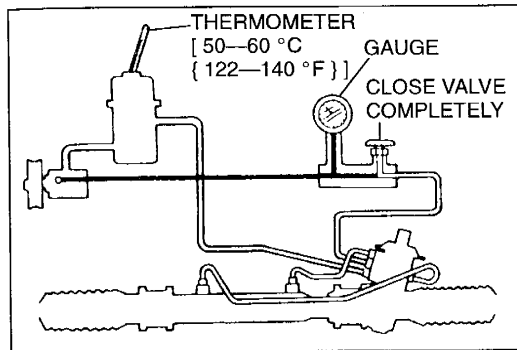

Caution

- **Do not let the valve stay closed for more than 5 seconds. The increase in fluid temperature will damage the oil pump.**

7. Close the gauge valve completely. Increase the engine speed to 1,000—1,500 rpm and measure the fluid pressure generated by the oil pump. If the pressure is not within specification, replace the oil pump assembly. (Refer to page N-24.)

N

**Oil pump fluid pressure: 8.58—9.32 MPa
{ 87.5—95.0 kgf/cm² , 1,244—1,350 psi }**

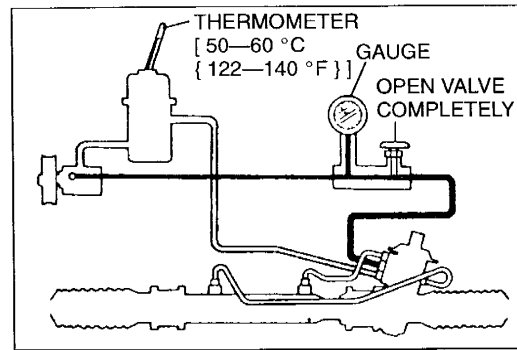

8. Open the gauge valve fully and increase the engine speed to 1,000—1,500 rpm.

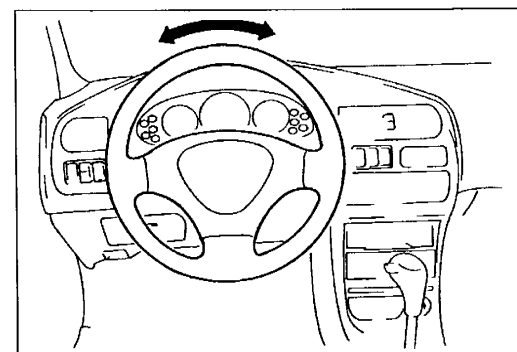

9. Turn the steering wheel fully left. Measure the fluid pressure generated within the gear housing. Turn the steering wheel fully right. Measure the fluid pressure generated within the gear housing. If the pressure is not within specification, repair or replace the steering gear assembly.

**Gear housing fluid pressure: 8.58—9.32 MPa
{ 87.5—95.0 kgf/cm² , 1,244—1,350 psi }**

10. Remove the gauge set. Install and tighten the pressure hose to the specified torque.

Tightening torque:

30—44 N·m { 3.0—4.5 kgf·m , 22—32 ft·lbf }

11. Bleed the air from the system. (Refer to page N-5.)

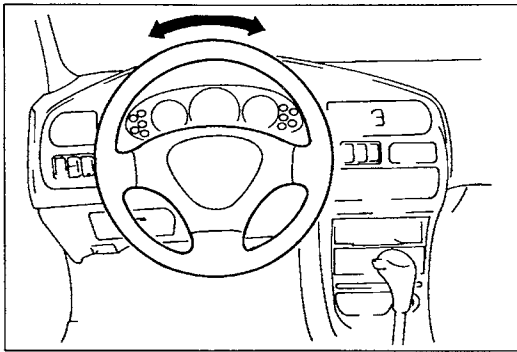

STEERING WHEEL AND COLUMN

On-vehicle Inspection

Steering wheel play

With the wheels in the straight-ahead position, gently turn the steering wheel left and right and verify that the play is within specification.

Play: 0—30 mm { 0—1.18 in }

If the play exceeds specification, either the steering joints are worn or the backlash of the steering gear is excessive.

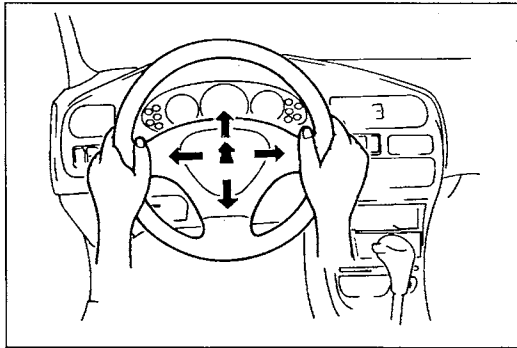

Looseness or play of steering wheel

Move the steering wheel in the directions shown to check for column bearing and bushing wear, steering shaft joint play, steering wheel looseness, and column looseness.

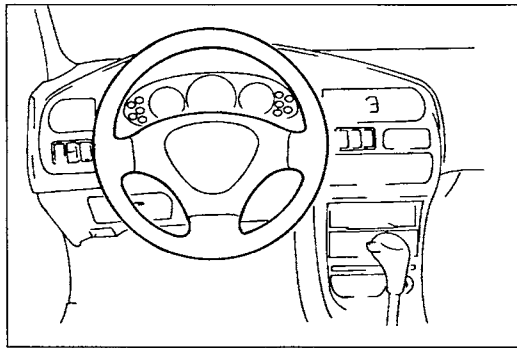

Steering wheel effort

1. Check the following points:
 - (1) Tire size and tire pressure
 - (2) Fluid level
 - (3) Drive belt deflection
2. With the vehicle on a hard, level surface, put the wheels in the straight-ahead position.
3. Start the engine and warm the power steering fluid to **50—60 °C { 122—140 °F }**.

Warning

- Refer to section T1 for removal and installation of the air bag module.

4. Remove the horn pad or air bag module.
5. Measure the steering wheel effort by using a torque wrench.

Steering wheel effort:

7.8 N·m { 80 kgf·cm , 69 in·lbf } max.

Note

- To determine whether the steering wheel effort is satisfactory or not, carry out the inspection with another vehicle of the same model and under the same conditions, and compare the results.
- The steering wheel effort varies with the conditions below.
 - a. Road condition such as dry or wet, and asphalt or concrete.
 - b. Tire condition such as brand, wear, and tire pressure.

6. If not within the specification, note the following:

- (1) Air in system
- (2) Fluid leakage at hose or connections
- (3) Function of oil pump and steering gear

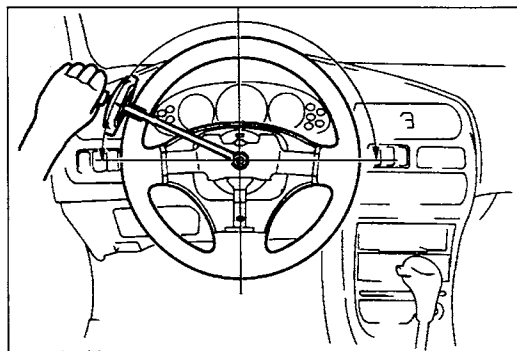

Removal / Inspection / Installation

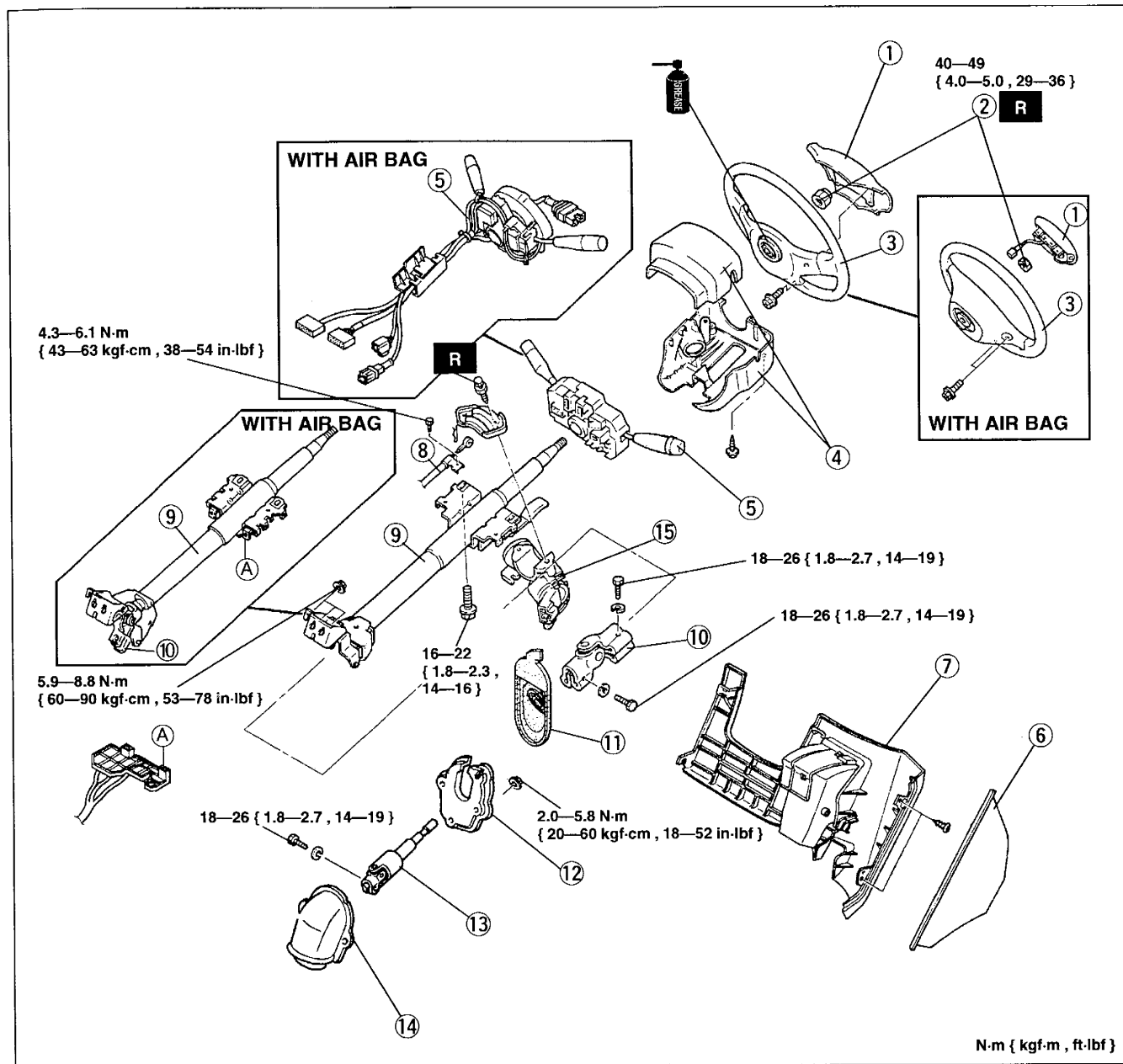

- | | |
|--|--|
| <p>1. Horn pad or air bag module
 Service section T1
 Installation Note page N-11</p> <p>2. Locknut</p> <p>3. Steering wheel
 Removal Note page N-10
 Installation Note page N-11</p> <p>4. Column cover</p> <p>5. Combination switch
 Removal / Installation section T1</p> <p>6. Side cover</p> <p>7. Under cover</p> <p>8. Interlock cable (ATX)</p> <p>9. Steering shaft assembly
 Inspection page N-10
 Installation Note page N-11</p> | <p>10. Universal joint
 Installation Note page N-11
 Inspect for looseness, abnormal noise, and sticking</p> <p>11. Boot</p> <p>12. Set plate</p> <p>13. Intermediate shaft
 Inspect for looseness, abnormal noise, and sticking</p> <p>14. Dust cover</p> <p>15. Steering lock
 Removal Note page N-10
 Installation Note page N-11
 Inspection page N-11</p> |
|--|--|

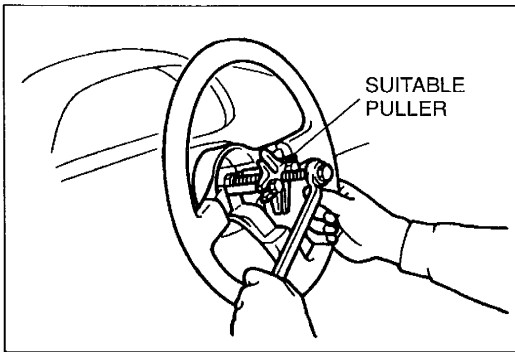

Removal note

Steering wheel

Caution

- Do not try to remove the steering wheel by hitting the shaft with a hammer. The column will collapse.

Remove the steering wheel by using a suitable puller.

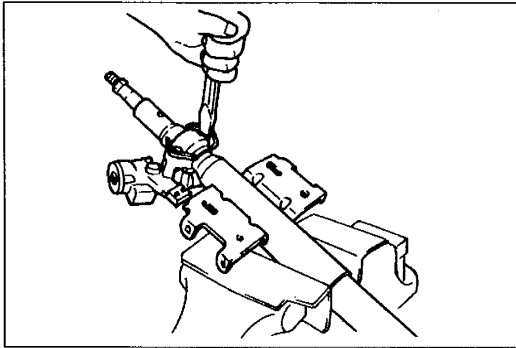

Steering lock

1. Use a chisel and a hammer to make a groove in the heads of the steering lock mounting bolts.
2. Remove the bolts by using a screwdriver.
3. Remove the steering lock assembly.

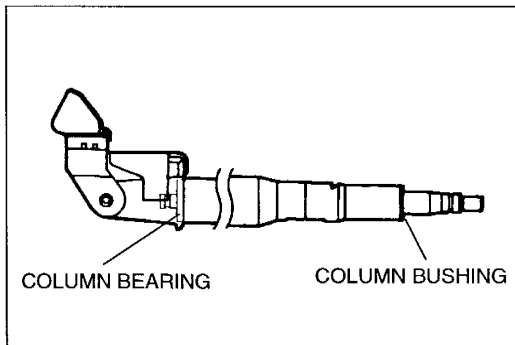

Inspection

Steering shaft assembly

Note the following and replace the steering shaft assembly if necessary.

1. Column bearing damage
2. Column bearing damage

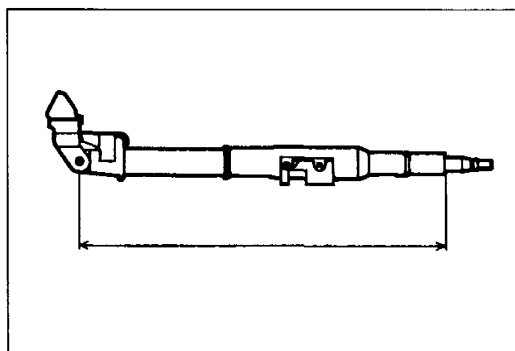

3. Steering shaft length

Length: 492.0—495.0 mm { 19.37—19.49 in }

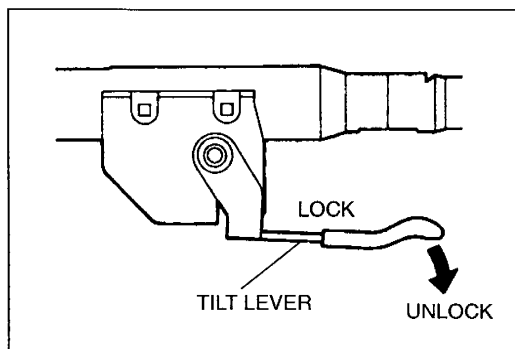

4. Tilt operation

- (1) Verify that the adjusting lever moves smoothly from unlock position to lock position.
- (2) Verify that the steering shaft is fixed firmly when the adjusting lever is locked.

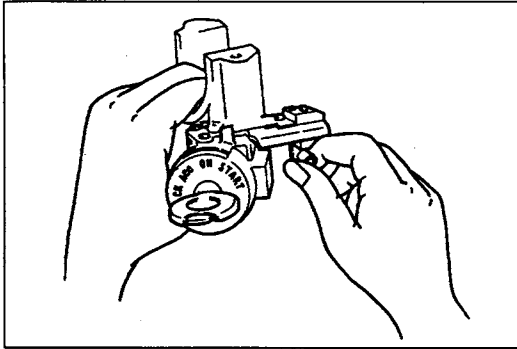

Steering lock (ATX)

Verify that the cable connector does not move when the key is in the LOCK position and that it moves freely with the key in other positions.

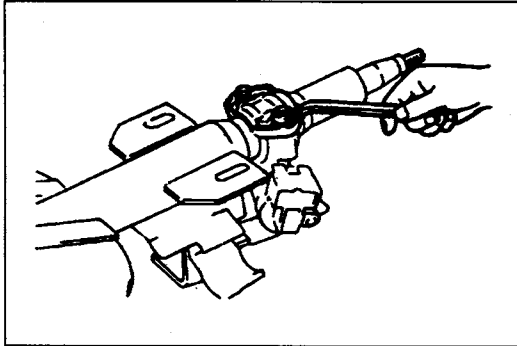

Installation note

Steering lock

1. Install the steering lock assembly on the jacket.
2. Verify that the lock operates correctly.
3. Install new steering lock mounting bolts.
4. Tighten the bolts until the heads break off.

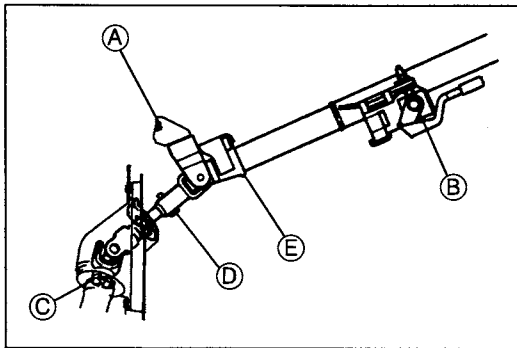

Steering shaft assembly and universal joint

Caution

- Do not apply the shock in the axial direction of the shaft.

1. Tighten bolts A, B and C.
2. Tighten bolt D with the steering shaft at its upper most tilt position.

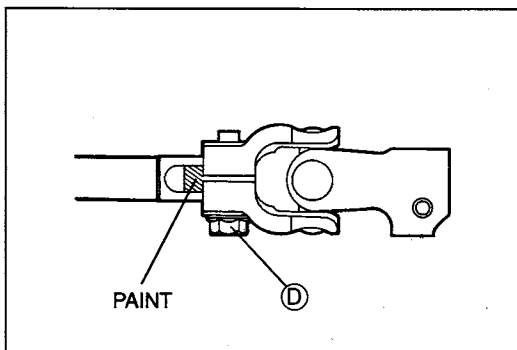

3. The paint must be visible after tightening the bolt D.
4. After installation, lightly tap the lower bracket at the E point shown by using a hammer to verify correct installation.

Steering wheel

Set the wheels in the straight-ahead position, and install the steering wheel.

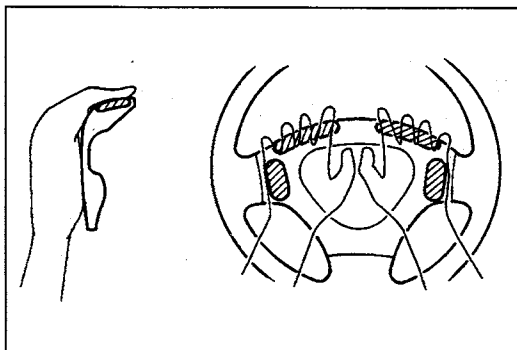

Horn pad (without air bag)

Caution

- Do not install the horn pad by tapping or pressing on one side at a time. The energy absorbing material on the back of the horn pad will become deformed and the horn will not operate if it is not properly installed.

Install the horn pad by lightly holding down the upper portion, then using both hands as shown in the figure, strongly and evenly press down on all sides.

STEERING GEAR AND LINKAGE

Removal / Installation

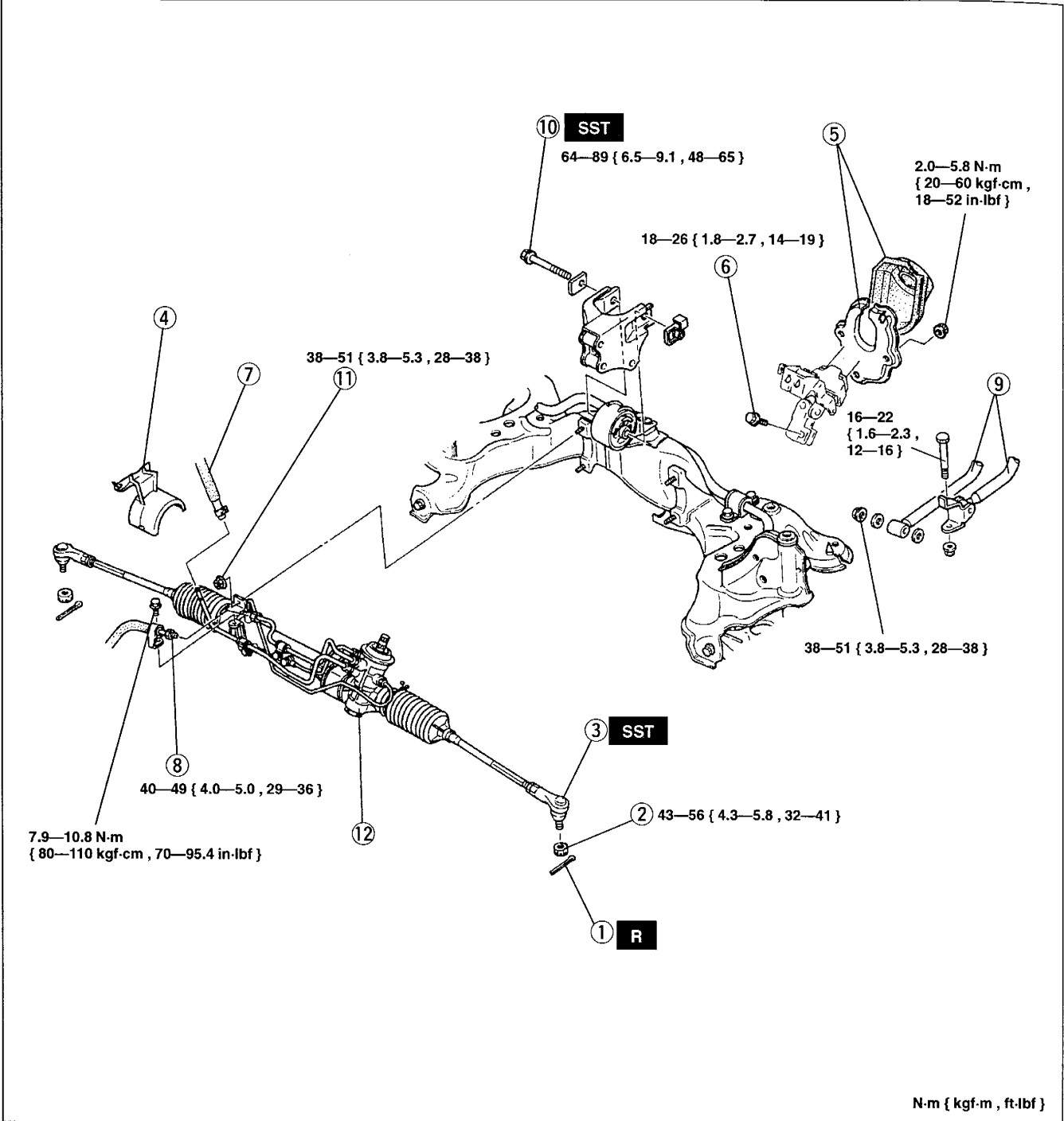

N-m { kgf-m , ft-lbf }

- 1. Cotter pin
- 2. Nut
- 3. Tie-rod end
Removal Note page N-13
- 4. Splash shield
- 5. Set plate and boot
- 6. Bolt (intermediate shaft)
- 7. Return hose
- 8. Pressure pipe

- 9. Extension bar/control rod (MTX)
- 10. Bolts (No.1 engine mount)
Removal Note page N-13
- 11. Mounting bracket nut
Installation Note page N-13
- 12. Steering gear and linkage
Removal Note page N-13
Disassembly / Inspection page N-14
Assembly page N-20

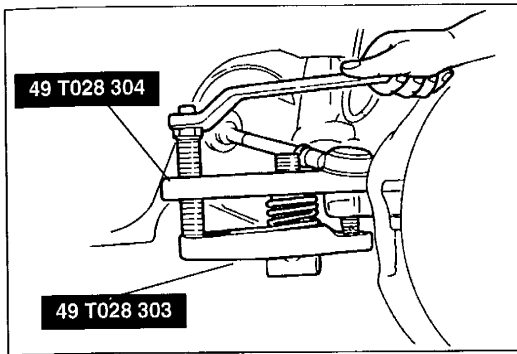

Removal note

Tie-rod end

1. Remove the tie rod nut.
2. Separate the tie-rod end from the steering knuckle by using the SSTs.

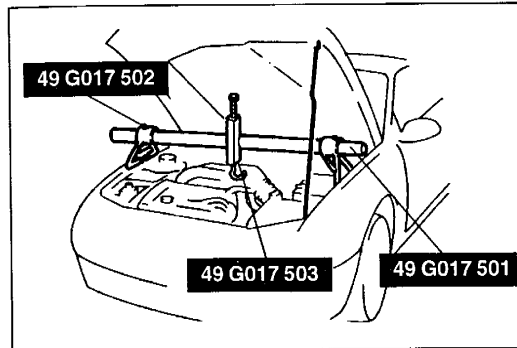

Bolt (No.1 engine mount)

1. Support the engine by using the SSTs.
2. Remove the engine mount bracket bolt.

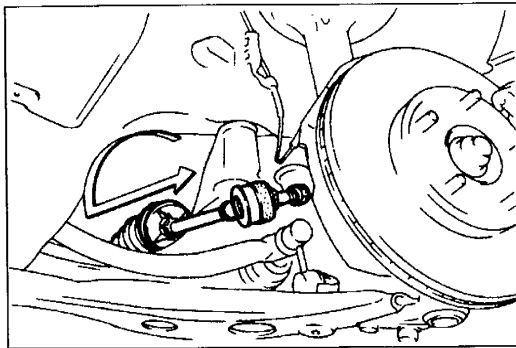

Steering gear and linkage

Remove the steering gear from the right side of the vehicle.

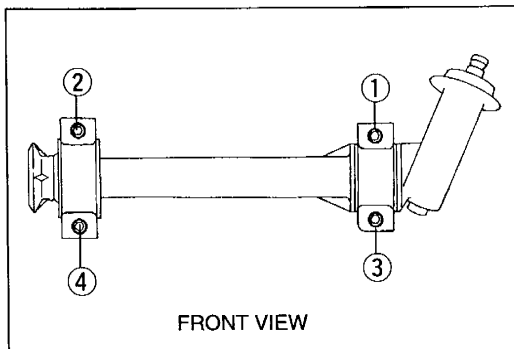

Installation note

Mounting bracket nuts

1. Hand-tighten the ④, ③ nuts.
2. Tighten the mounting bracket nuts to the specified torque in order shown.

Tightening torque:

38—51 N·m { 3.8—5.3 kgf·m , 28—38 ft·lbf }

Disassembly / Inspection

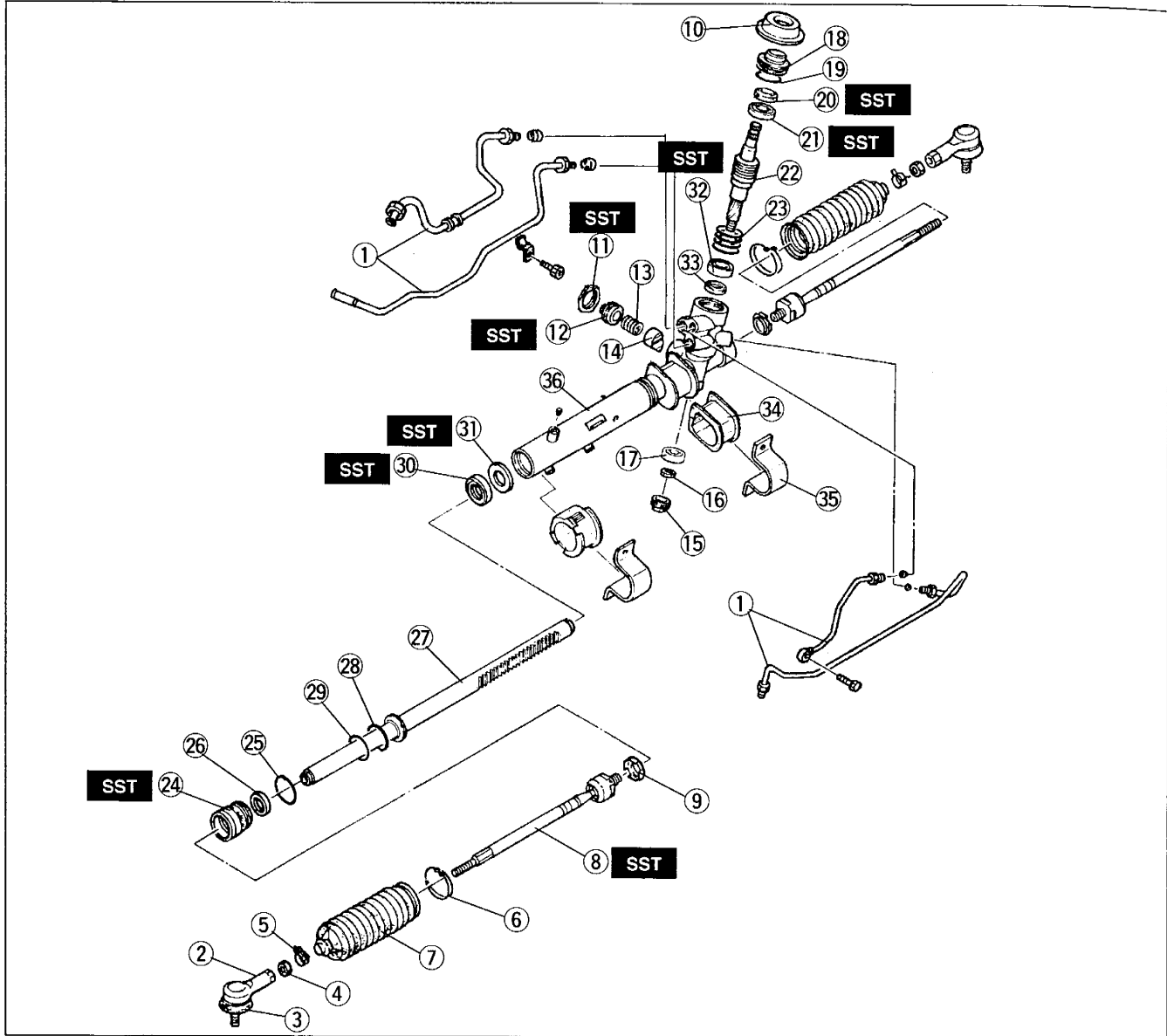

- | | |
|---|--|
| <p>1. Oil pipe
Disassembly Note page N-15
Inspect for clogging and damage</p> <p>2. Tie-rod end
Disassembly Note page N-15
Inspection page N-17</p> <p>3. Tie-rod end boot
Disassembly Note page N-15</p> <p>4. Locknut</p> <p>5. Boot clamp</p> <p>6. Boot wire</p> <p>7. Boot
Inspect for cracking and tearing</p> <p>8. Tie rod
Disassembly Note page N-15
Inspection page N-18</p> <p>9. Washer</p> <p>10. Dust cover</p> | <p>11. Locknut
Disassembly Note page N-16</p> <p>12. Adjusting cover
Disassembly Note page N-16</p> <p>13. Yoke spring
Inspect for damage</p> <p>14. Support yoke
Inspect for damage</p> <p>15. Housing cover
Disassembly Note page N-16</p> <p>16. Locknut</p> <p>17. Bearing</p> <p>18. Plug
Inspection page N-18</p> <p>19. O-ring</p> <p>20. Oil seal
Disassembly Note page N-16</p> <p>21. Bearing
Disassembly Note page N-16</p> |
|---|--|

- 22. Pinion shaft assembly
Inspect teeth for wear and damage
Inspect valve for clogging, damage and wear
- 23. Seal ring
- 24. Outer box assembly
Disassembly Note page N-16
- 25. O-ring
- 26. U-gasket
- 27. Steering rack
Inspection page N-18
- 28. Seal ring
- 29. O-ring

- 30. Oil seal
Disassembly Note page N-17
- 31. Inner guide
Disassembly Note page N-17
- 32. Oil seal (pinion)
Disassembly Note page N-17
- 33. Collar
- 34. Mounting rubber
- 35. Mounting bracket
- 36. Gear housing
Inspect for damage and cracks

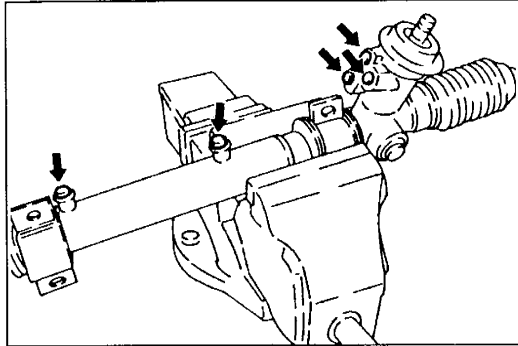

Disassembly note

Oil pipe

1. Secure the gear in a vise.
2. Remove the oil pipe.

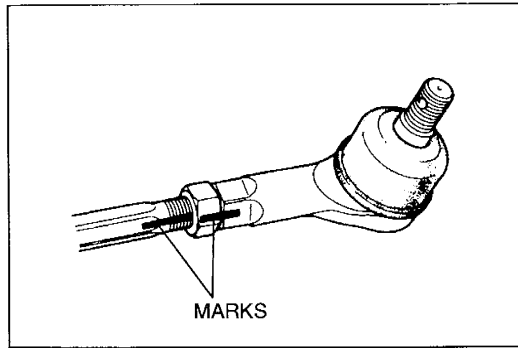

Tie-rod end

Mark the tie-rod end before loosening, for reference during installation.

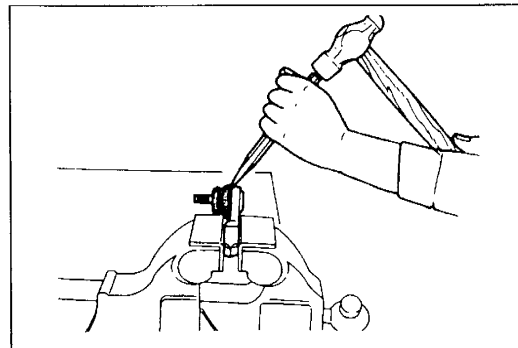

Tie-rod end boot

1. Secure the tie-rod end in a vise.
2. Place a chisel against the boot and hold it at the angle shown.
3. Remove the boot by tapping with a hammer.

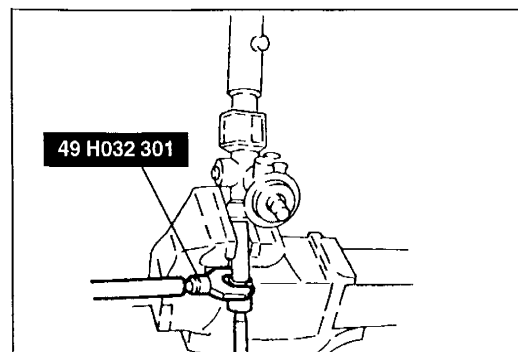

Tie rod

1. Unbend the washer.
2. Remove the tie rod by using the SST.

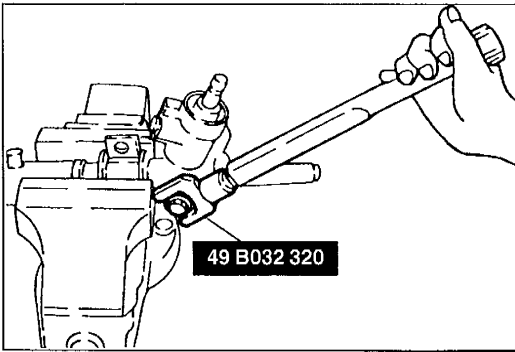
**Locknut**

Remove the locknut by using the **SST**.

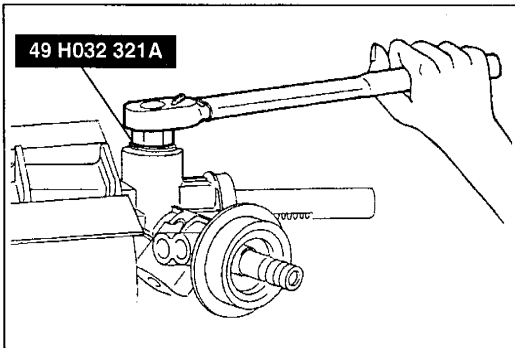
**Adjusting cover**

Remove the adjusting cover by using the **SST**.

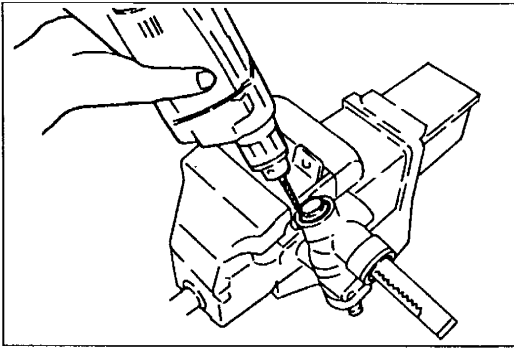
**Housing cover**

1. Drill away the stake areas.
2. Remove the housing cover.

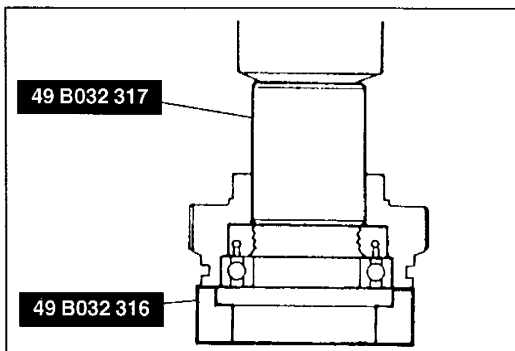
**Oil seal and bearing**

Remove the oil seal and bearing by using the **SSTs**.

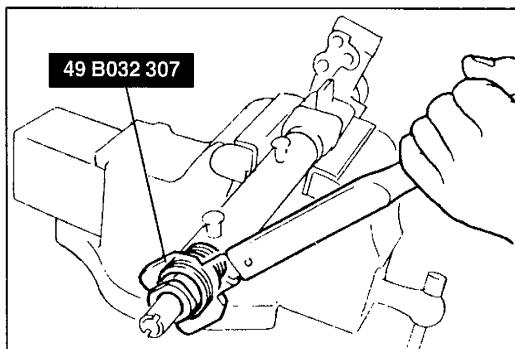
**Outer box assembly**

Remove the outer box by using the **SST**.

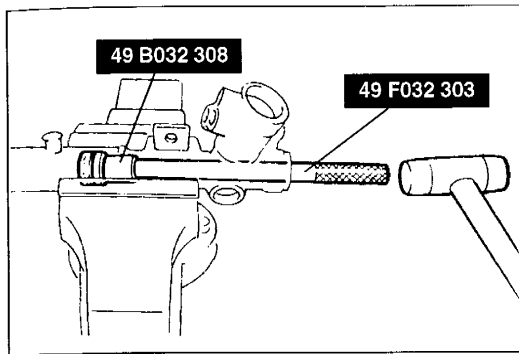
**Oil seal and inner guide**

Remove the oil seal and inner guide by using the **SSTs**.

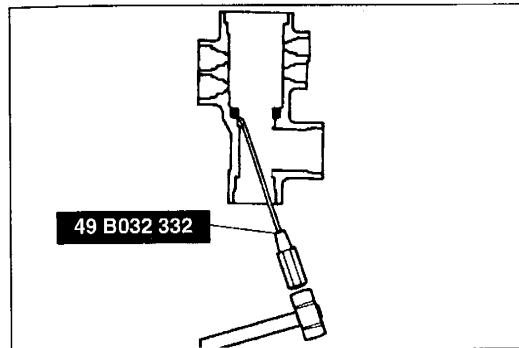
**Oil seal (pinion)**

Remove the oil seal by using the **SST**.

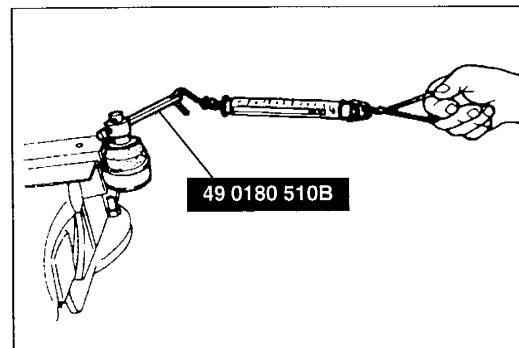
**Inspection****Tie-rod end**

1. Inspect the tie-rod end for damage and boot cracks. Replace it if necessary.
2. Inspect the ball joint for looseness. Replace the tie-rod end as necessary.
3. Rotate the ball joint five times.
4. Measure the rotation torque of the ball joint by using the **SST** and a pull scale.

Rotation torque:

0.3—2.9 N·m { 3—30 kgf·cm , 2.6—26 in·lbf }

Pull scale reading:

3—29 N { 0.3—3.0 kgf , 0.7—6.6 lbf }

5. If not within specification, replace the tie-rod end.

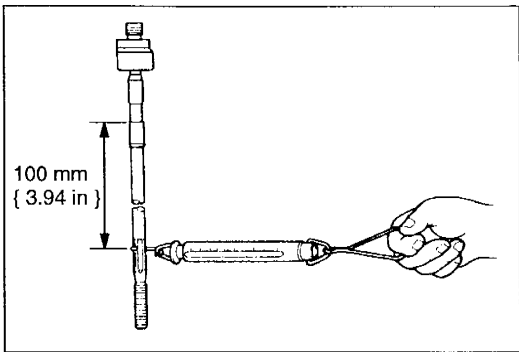

Tie rod

1. Inspect the tie rod for bending and damage. Replace it if necessary.
2. Inspect the ball joint for looseness. Replace the tie rod as necessary.
3. Swing the tie rod five times.
4. Measure the swinging torque by using a pull scale.

Swinging torque:

0.1—3.4 N·m { 1—35 kgf·cm , 0.9—30 in·lbf }

Pull scale reading:

0.7—21 N { 0.07—2.2 kgf , 0.16—4.8 lbf }

5. If not within specification, replace the tie rod.

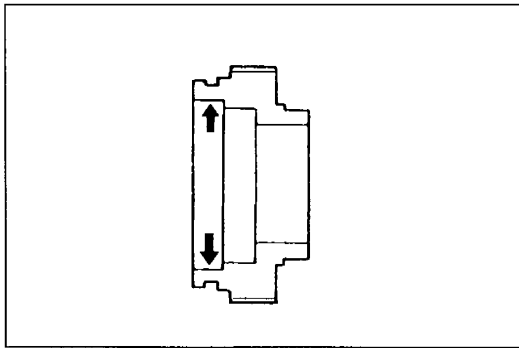

Plug

Inspect for scratches or other damage at the oil seal installation inner diameter and replace it if necessary.

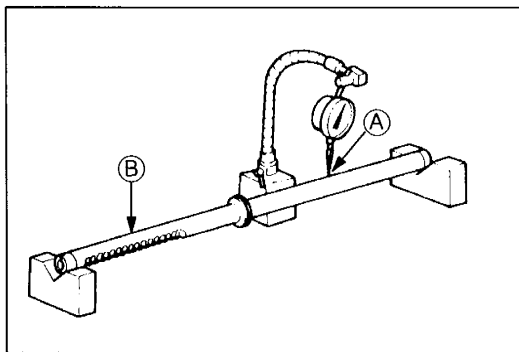

Steering rack

1. Inspect for cracking, damage, and tooth wear. Replace if necessary.
2. Measure the runout of the rack.

Runout **A**: 0.3 mm { 0.012 in } max.

B: 0.4 mm { 0.016 in } max.

3. If not within specification, replace the rack.

MEMO

Assembly

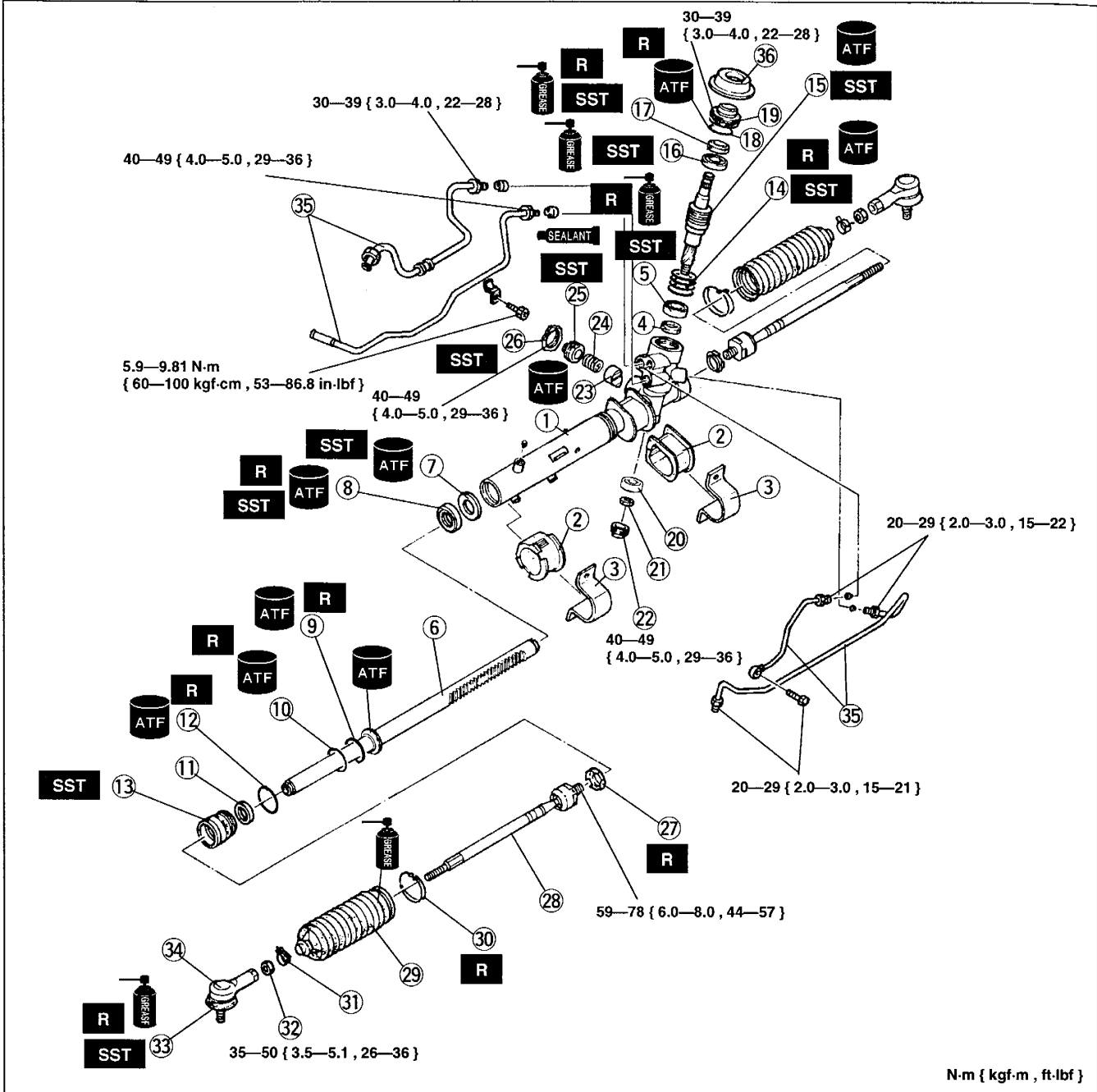

N-m { kgf-m, ft-lbf }

- | | |
|-------------------------------|----------------------------------|
| 1. Gear housing | 13. Outer box assembly |
| 2. Mounting rubber | Assembly Note page N-22 |
| 3. Mounting bracket | 14. Seal ring |
| 4. Collar | Assembly Note page N-22 |
| 5. Oil seal (pinion) | 15. Pinion shaft assembly |
| Assembly Note page N-21 | Assembly Note page N-22 |
| 6. Steering rack | 16. Bearing |
| Assembly Note page N-21 | Disassembly Note page N-23 |
| 7. Inner guide | 17. Oil seal |
| 8. Oil seal (rack) | Assembly Note page N-23 |
| 9. O-ring | 18. O-ring |
| 10. Seal ring | 19. Plug |
| 11. U-gasket | 20. Bearing |
| 12. O-ring | 21. Locknut |

- 22. Housing cover
- 23. Support yoke
- 24. Yoke spring
- 25. Adjusting cover
Assembly Note page N-23
- 26. Locknut
Assembly Note page N-23
- 27. Washer
- 28. Tie rod
- 29. Boot
- 30. Boot wire

- 31. Boot clamp
- 32. Locknut
- 33. Tie-rod end boot
Assembly Note page N-23
- 34. Tie-rod end
Assembly Note page N-24
- 35. Oil pipe
- 36. Dust cover

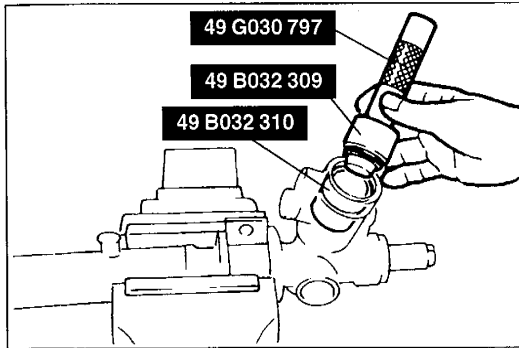

**Assembly note
Oil seal (pinion)**

1. Apply grease to the new oil seal.
2. Install the oil seal in the gear housing by using the **SSTs**.

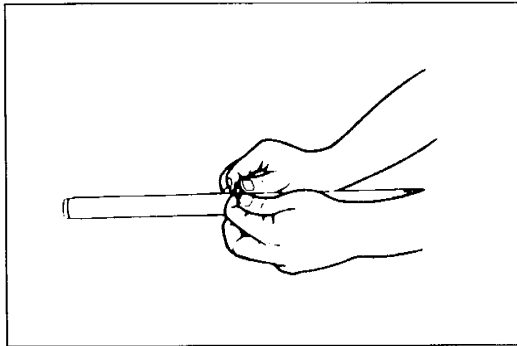

Steering rack

1. Apply ATF to a new O-ring and seal ring.
2. Install the O-ring and seal ring in the groove.
3. Hold the seal ring and O-ring.

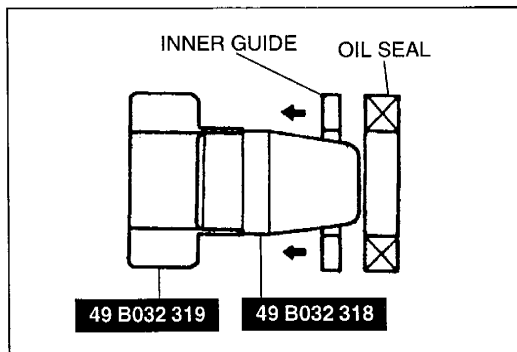

4. Apply ATF to the inner guide and oil seal.
5. Install the inner guide and oil seal to the **SST** (49 B032 319) by using the **SST** (49 B032 318).

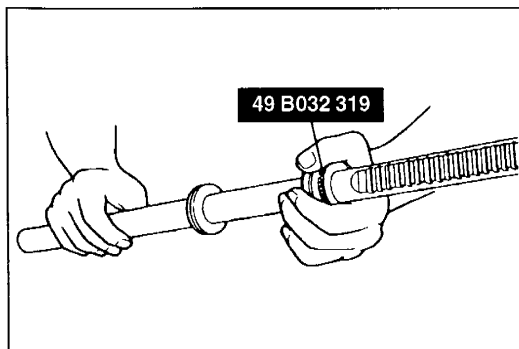

6. Place the oil seal and inner guide at the edge of the steering rack's pinion by using the **SST**.
7. Remove the **SST**.

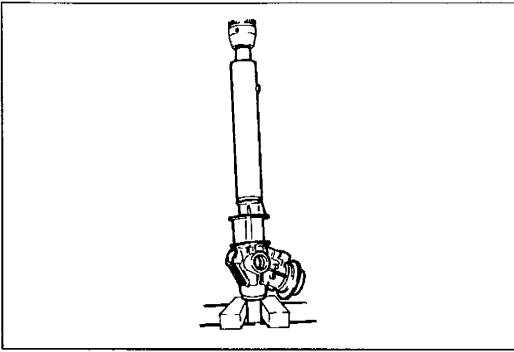

8. Install the steering rack in to gear box.
9. Press the oil seal and inner guide to the correct position.

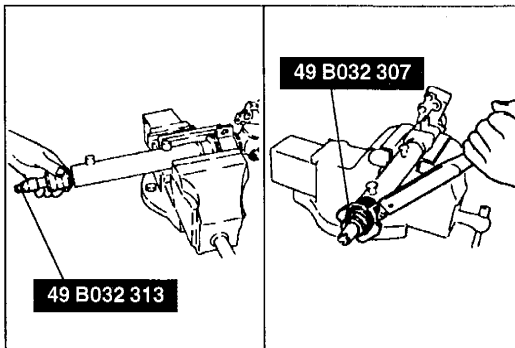

Outer box assembly

1. Install the **SST** (49 B032 313) to the steering rack.
2. Install the outer box, and use the **SST** (49 B032 307) to tighten.
3. Remove the **SST** (49 B032 313).

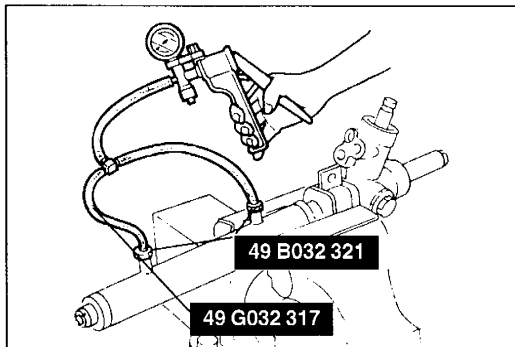

(Hermetic sealing inspection of cylinder)

1. Connect the **SST** (49 B032 321) to the cylinder housing.
2. Connect a vacuum pump to the **SST** (49 G032 317) and apply **53.3 kPa { 400 mmHg , 15.7 inHg }** vacuum.
3. Verify that vacuum is held for at least **30 seconds**. If not, replace the oil seal.

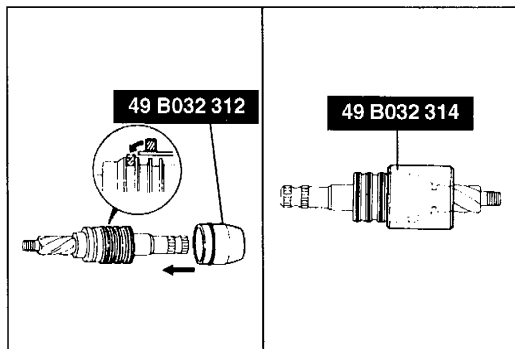

Seal ring

1. Install the new seal ring to the pinion shaft by using the **SST** (49 B032 312).
2. Slide the **SST** (49 B032 314) over the seal ring until they are set in the grooves.

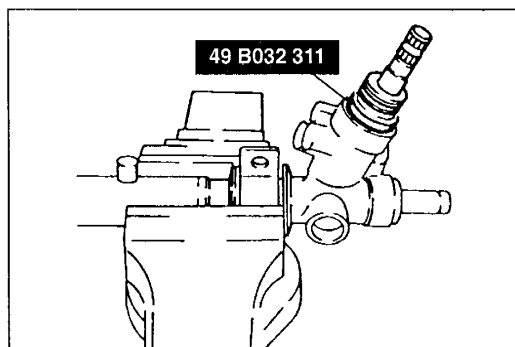

Pinion shaft assembly

Install the pinion shaft assembly to the gear housing by using the **SST**.

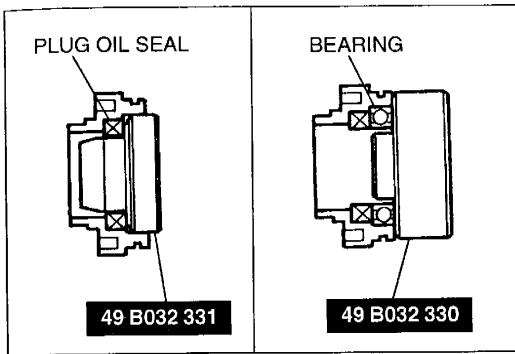

Oil seal and bearing

1. Apply grease to the oil seal and bearing.
2. Install the oil seal and bearing to the plug by using the SSTs.

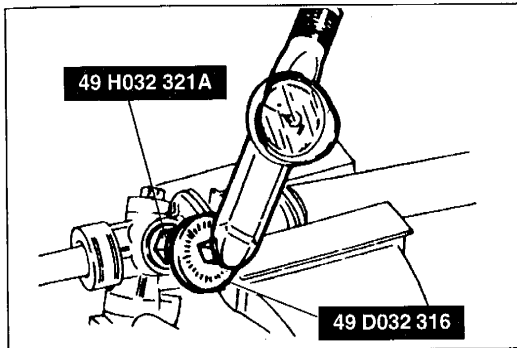

Adjusting cover and locknut

1. Apply sealant to the threads of the adjusting cover.
2. Tighten the adjusting cover to **4.9 N·m { 50 kgf·cm , 43 in-lbf }** by using the SSTs and return it about **45 degrees**.

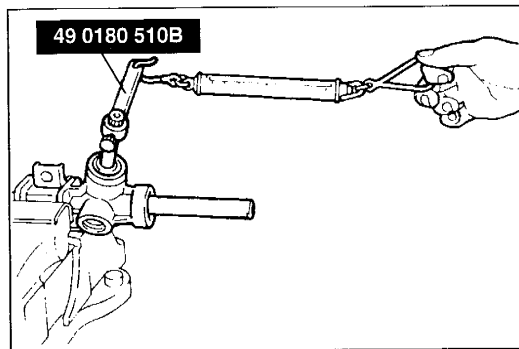

(Inspection of pinion preload)

3. Attach the SST and a pull scale to the pinion shaft.
4. Measure the pinion preload.

Rack position: Center ± 90°

Pinion preload: 1.0—1.2 N·m { 10—12 kgf·cm , 8.7—10.4 in-lbf } max.

Pull scale reading: 9.9—12 N { 1.0—1.4 kgf , 2.2—2.6 lbf }

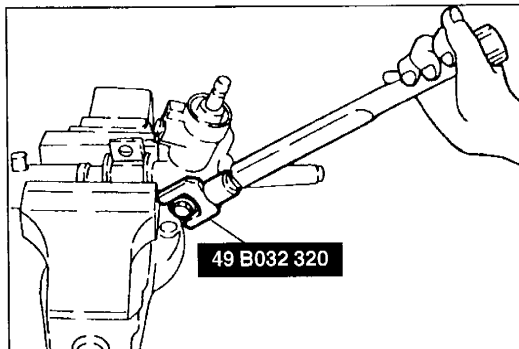

5. If not to specification, readjust by turning the adjusting cover **0—45 degrees**.
6. Apply the sealant to the threads of the locknut.
7. Tighten the locknut while holding the adjusting cover by using the SST.

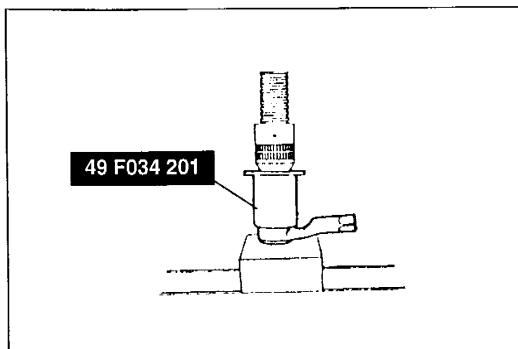

Tie-rod end boot

1. Wipe away the grease on the ball joint.
2. Put a small amount of grease (lithium-based) into the new boot and set it onto the tie-rod end.
3. Press the boot onto the tie-rod end by using the SST and a press.
4. Wipe away any grease expelled from the dust boot.

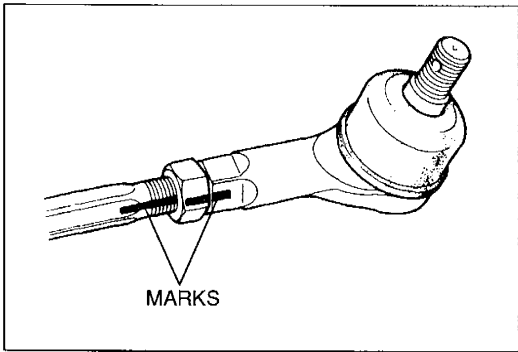

Tie-rod end

Install the tie-rod end, aligning the marks made before disassembly.

**POWER STEERING OIL PUMP
Removal / Installation**

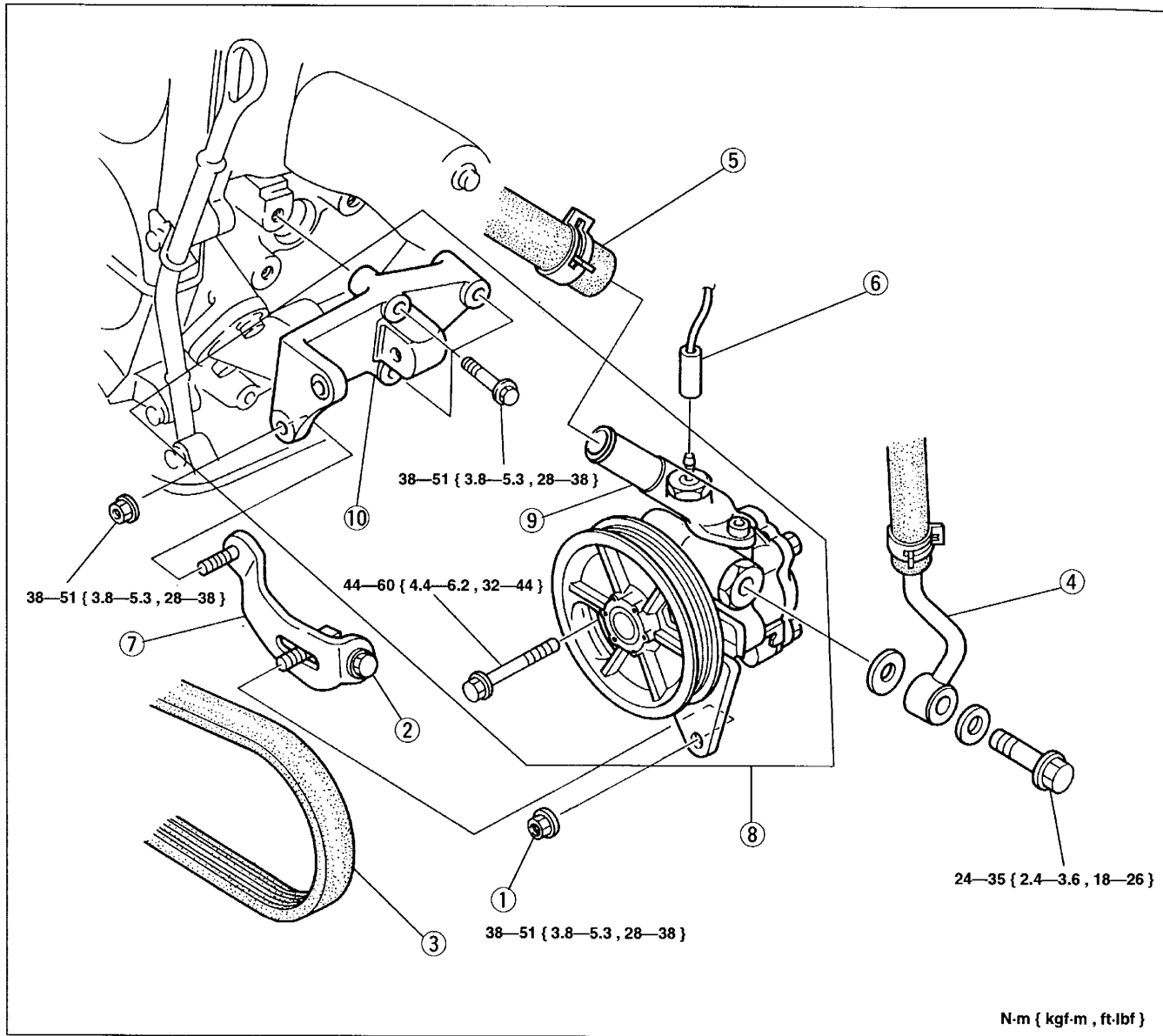

- 1. Locknut
- 2. Adjusting bolt
- 3. Drive belt
- Service section B1, B2
- 4. Pressure pipe
- 5. Return hose

- 6. PSP switch connector
- 7. Pump bracket
- 8. Power steering pump bracket and pump
- 9. Power steering pump
- Disassembly / Inspection /
Assembly page N-25

Disassembly / Assembly

The following procedure is for replacement of the O-rings only. Replace the pump assembly if other repairs are necessary.

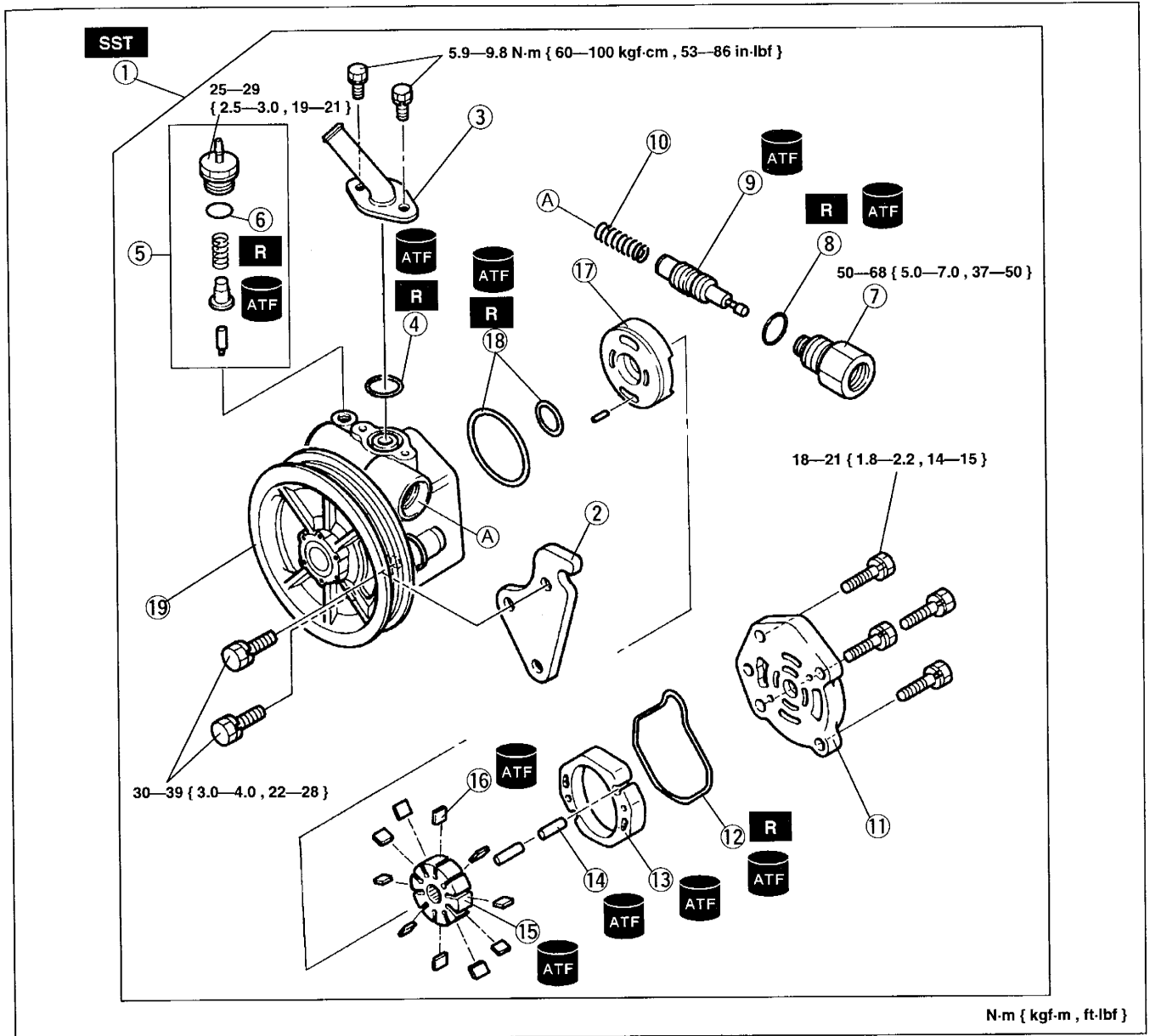

- | | |
|---|---|
| <ul style="list-style-type: none"> 1. Oil pump
Disassembly Note page N-26 2. Bracket 3. Suction pipe 4. O-ring 5. PSP switch assembly 6. O-ring 7. Connector 8. O-ring 9. Control valve
Inspect for clogging, cracks, and damage 10. Spring
Inspect for weakness 11. Pump body (Rear)
Assembly Note page N-26
Inspect for cracks, wear, and damage | <ul style="list-style-type: none"> 12. O-ring 13. Cam ring
Assembly Note page N-26
Inspect for wear and damage 14. Pin 15. Rotor
Assembly Note page N-26
Inspect for wear and damage 16. Blade
Assembly Note page N-26
Inspect for wear and damage 17. Side plate
Inspect for wear and damage 18. O-ring 19. Pump body (Front)
Inspect for cracks, wear, and damage |
|---|---|

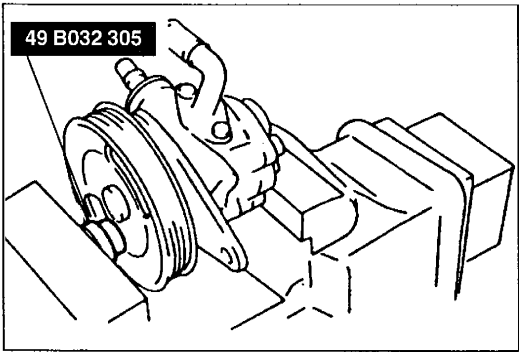

Disassembly note
Oil pump

Caution

- Use the SST to prevent damage to the pump when securing it in a vise.

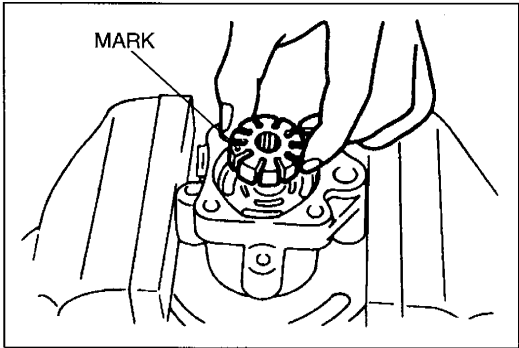

Assembly note
Rotor

Install the rotor to the shaft with rotor's identification mark facing upward.

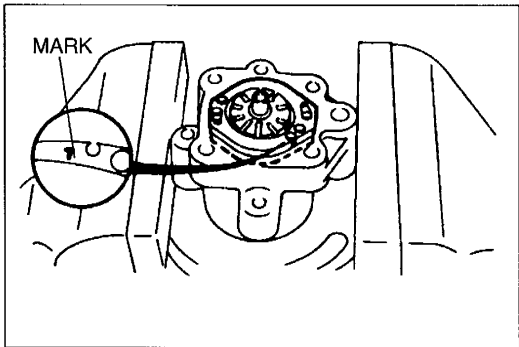

Cam ring

Install the cam ring in the pump body (front) with the mark facing downward.

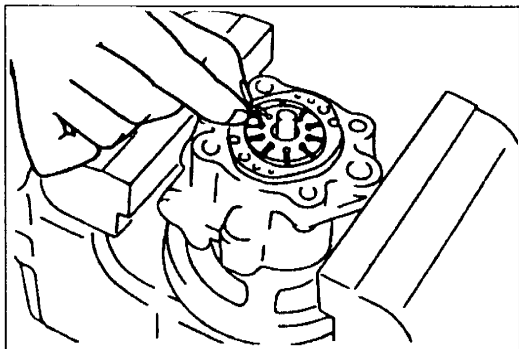

Blade

Place the blades in the rotor with the rounded edges contacting the cam.

Pump body (Rear)

After installing the pump body (rear), manually turn the shaft to verify that it rotates smoothly.

Before beginning any service procedure, refer to section T1 of this manual for air bag system service warnings.

BRAKING SYSTEM

OUTLINE	P- 2
SPECIFICATIONS	P- 2
GENERAL PROCEDURES	P- 3
CONVENTIONAL BRAKE SYSTEM	P- 3
PREPARATION	P- 3
AIR BLEEDING	P- 4
VACUUM LINE	P- 5
BRAKE PEDAL	P- 5
MASTER CYLINDER	P- 8
POWER BRAKE UNIT	P-13
DUAL PROPORTIONING VALVE	P-16
FRONT BRAKE (DISC)	P-17
DISC PAD (FRONT)	P-19
CALIPER (FRONT)	P-20
REAR BRAKE (DISC)	P-21
DISC PAD (REAR)	P-23
CALIPER (REAR)	P-24
REAR BRAKE (DRUM)	P-25
WHEEL CYLINDER	P-28
PARKING BRAKE SYSTEM	P-28
PARKING BRAKE (LEVER TYPE)	P-28
ANTILOCK BRAKE SYSTEM (ABS)	P-30
PREPARATION	P-30
ABS HYDRAULIC UNIT	P-31
ABS CONTROL MODULE	P-34
ABS RELAY	P-37
ABS WHEEL-SPEED SENSOR (FRONT)	P-40
ABS WHEEL-SPEED SENSOR (REAR)	P-41
ON-BOARD DIAGNOSTIC FUNCTION	P-42
TROUBLESHOOTING	P-48

OUTLINE

SPECIFICATIONS

Item		Engine	Z5	BP
Brake pedal	Type		Suspended	
	Pedal lever ratio		4.11	
	Max. stroke	mm { in }	140 { 5.51 }	
Master cylinder	Type		Tandem (with level sensor)	
			Conventional (Non-ABS), Port-less (ABS)	
	Cylinder inner diameter	mm { in }	23.8 { 0.937 }	
Front disc brake	Type		Ventilated disc	
	Cylinder bore	mm { in }	54.0 { 2.12 }	
	Pad dimensions (area × thickness) mm ² { in ² } × mm { in }		3800 × 10 { 5.89 × 0.39 }	4300 × 10 { 6.66 × 0.39 }
	Disc plate dimensions (outer diameter × thickness) mm { in }		235 × 22 { 9.25 × 0.87 }	257 × 22 { 10.1 × 0.87 }
Rear disc brake	Type		—	Solid disc
	Cylinder bore	mm { in }	—	30.2 { 1.19 }
	Pad dimensions (area × thickness) mm ² { in ² } × mm { in }		—	2600 × 8.0 { 4.03 × 0.31 }
	Disc plate dimensions (outer diameter × thickness) mm { in }		—	251 × 9.0 { 9.88 × 0.35 }
Rear drum brake	Type		Leading-trailing	—
	Wheel cylinder inner diameter	mm { in }	19.0 { 0.75 }	—
	Lining dimensions (width × length × thickness) mm { in }		35.0 × 192.0 × 4.0 { 1.38 × 7.56 × 0.16 }	—
	Drum inner diameter	mm { in }	200 { 7.87 }	—
	Shoe clearance adjustment		Automatic adjuster	—
Power brake unit	Type		Vacuum multiplier	
	Diameter	mm { in }	MTX : 239 { 9.4 } ATX : 188+215 { 7.4+8.5 }	
Braking force control device	Type		Dual proportioning valve	
Brake fluid			FMVSS116: DOT3	
Parking brake	Type		Mechanical two-rear-wheel control	
	Operation system		Center lever	

GENERAL PROCEDURES

Removal / Installation, Disassembly / Assembly

- The numbers in the structural view indicate the removal and disassembly order. For installation and assembly, follow the reverse order.

Wheels and tires

- The removal and installation procedures for the wheels and tires are not mentioned in this section. If you must remove a wheel, retighten it to **89—127 N·m { 9.0—13.0 kgf·m , 66—94 ft·lbf }**.

Brake lines

Caution

- Brake fluid will damage painted surfaces. If brake fluid does get on a painted surface, wipe it off immediately.**
- Tighten the brake pipe flare nut by using the **SST (49 0259 770B)**. Be sure to modify the brake pipe flare nut tightening torque to allow for use of a torque wrench-SST combination. (Refer to section GI “Torque Formulas”.)
- If a brake line(s) has been disconnected anytime during the procedure, add brake fluid, bleed the brakes, and inspect for leakage after the procedure has been completed.

Connectors

- Disconnect the negative battery cable before doing any work that requires handling of connectors. Reconnect the negative battery cable only after the work is completed.



ABS components

- Make sure that there are no diagnostic trouble codes in the ABS memory after working on ABS components. If there are any codes in the memory, erase them.

CONVENTIONAL BRAKE SYSTEM

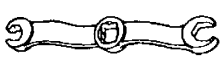
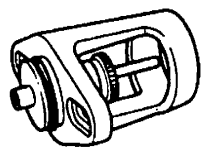
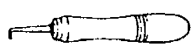
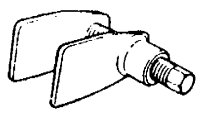
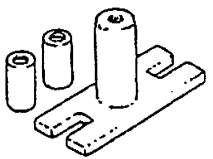
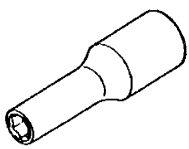
PREPARATION SST

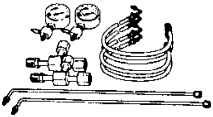
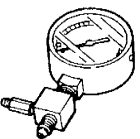
49 0259 770B Wrench, flare nut 	For removal of brake pipe	49 B043 001 Adjust gauge 	For adjustment of push rod clearance
49 0208 701A Air-out tool, boot 	For removal of piston seal	49 0221 600C Expand tool, disc brake 	For installation of brake pads
49 E043 003A Lock tool, turning 	For adjustment of push rod clearance	49 B043 004 Socket wrench 	For adjustment of push rod clearance

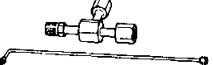
<p>49 U043 0A0</p> <p>Gauge set, oil pressure</p> 	<p>For inspection of brake fluid pressure</p>	<p>49 U043 004</p> <p>Gauge, oil pressure (Part of 49 U043 0A0)</p> 	<p>For inspection of brake fluid pressure</p>
<p>49 U043 006</p> <p>Hose (Part of 49 U043 0A0)</p> 	<p>For inspection of brake fluid pressure</p>	<p>49 U043 005</p> <p>Joint (Part of 49 U043 0A0)</p> 	<p>For inspection of brake fluid pressure</p>

AIR BLEEDING

Note

- The brakes should be bled whenever a brake line is disconnected. If a hydraulic line is disconnected at the master cylinder, start at the slave cylinder farthest from the brake master cylinder, and move to the next farthest slave cylinder until all four cylinders have been bled. If the disconnection point is anywhere except the master cylinder, start at the point closest to the disconnection, and move to the next closest slave cylinder until all four cylinders have been bled.

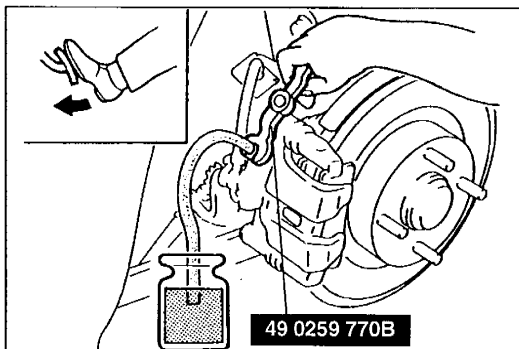
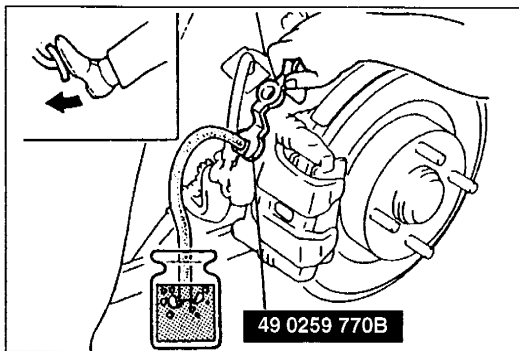
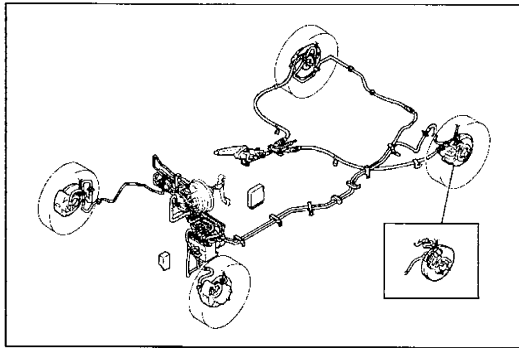

1. On level ground , jack up the vehicle and support it evenly on safety stands.
2. Remove the bleeder cap and attach a vinyl tube to the bleeder screw.
3. Place the other end of the vinyl tube in a clear fluid-filled container.
4. One person should depress the brake pedal a few times, and then hold it in the depressed position.
5. A second person should loosen the bleeder screw, drain out the fluid, and close the screw by using the **SST**.
6. Repeat step 4 and 5 until no air bubbles are seen. The reservoir should be kept about 3/4 full during bleeding to prevent air from reentering the lines.

Tightening torque

Front:

6.9—9.8 N·m { 70—100 kgf·cm , 61—86 in·lbf }

Rear:

5.9—8.8 N·m { 60—90 kgf·cm , 53—78 in·lbf }

7. Check for correct brake operation.
8. Verify that there is no fluid leakage. Wipe off any spilled fluid immediately.
9. After bleeding the brakes, add brake fluid to MAX.

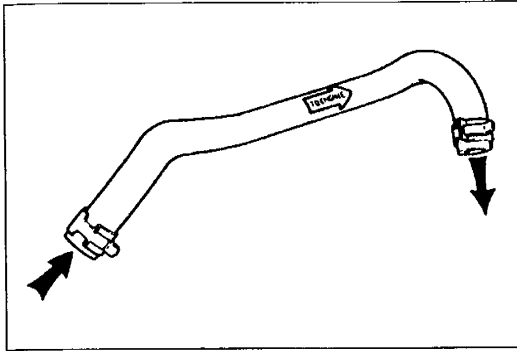

VACUUM LINE

Inspection

1. Remove the clamps and the hose.
2. Apply both suction and pressure to the engine-side of the hose, and verify that air flows only toward that side. If air flows in both directions or not at all, replace the vacuum hose.

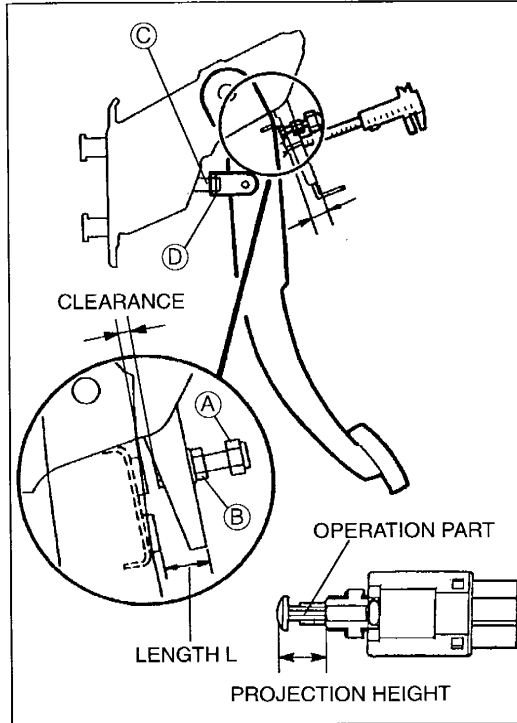

BRAKE PEDAL

Inspection (On-vehicle)

Brake pedal height

Inspection

1. Remove the brake switch.
2. Measure length L.

Length L: 17.9—21.9 mm { 0.71—0.86 in }

3. If length L is within the specification, reinstall the switch.

Adjustment

1. Loosen locknut B and turn self-locknut A until it does not contact the pedal.
2. Loosen locknut D and turn rod C to adjust the height.
3. Tighten locknut D.

Tightening torque:

24—34 N·m { 2.4—3.5 kgf·m , 18—25 ft·lbf }

4. Turn self-locknut A so that the clearance between self-locknut A and the pedal is **0.1—1.0 mm { 0.004—0.039 in }**.
5. Tighten locknut B.

Tightening torque:

14—17 N·m { 1.4—1.8 kgf·m , 11—13 ft·lbf }

Caution

- When the brake pedal height is adjusted, a new brake switch must be used.
- The new switch can be adjusted only once.
- Pulling or pushing the tip of the new brake switch can damage the inner parts.

6. Install a new brake switch.

Note

- The new brake switch projection height is adjusted automatically in step 7.

7. Pull the brake pedal until you hear the tip of the brake switch click.
8. Inspect the pedal play and the brake light operation.
9. If the brake light does not operate, replace the brake switch and repeat steps 6—8.

P

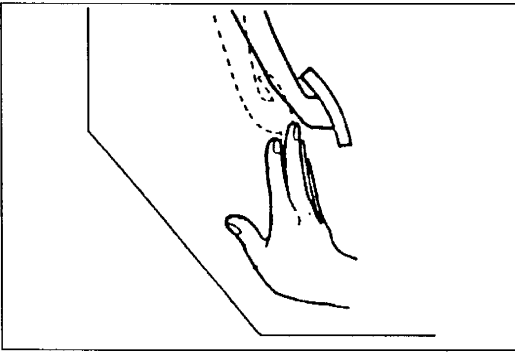
**Pedal play****Inspection**

1. Depress the pedal a few times to eliminate the vacuum in the system.
2. Remove the snap pin, verify that the holes in the fork and in the pedal are aligned, and reinstall the pin.
3. Gently depress the pedal by hand and check the free play (until resistance is felt).

Pedal play: 4—12 mm { 0.16—0.47 in }

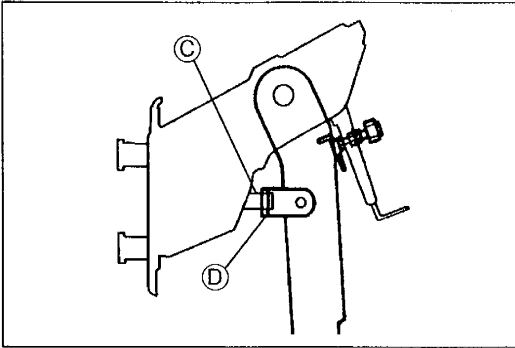
**Adjustment**

1. Remove the snap pin and the clevis pin.
2. Loosen locknut D and turn rod C to align the holes in the fork and in the pedal.
3. Install the clevis pin and the snap pin.
4. Verify the pedal height and the brake light operation.

Tightening torque:

24—34 N·m { 2.4—3.5 kgf·m , 17—25 ft·lbf }

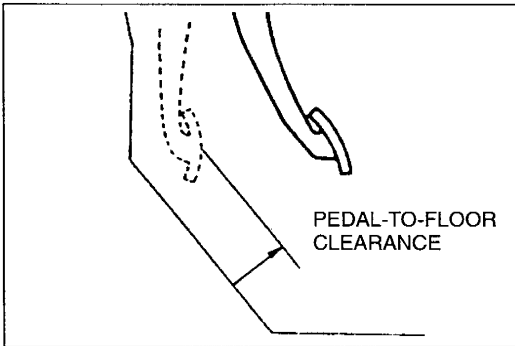
**Pedal-to-floor clearance****Inspection**

Verify that the distance from the floor panel to the pedal pad center is as specified when the pedal is depressed with a force of **590 N { 60 kgf , 130 lbf }**.

Pedal-to-floor clearance: 70 mm { 2.8 in } min.

If the distance is less than specified, check for the following problems.

1. Air in brake system
2. Malfunction of automatic adjuster
3. Worn pads/shoes

Removal / Inspection / Installation

- After installation, check and adjust the pedal height and free play. (Refer to page P-6.)

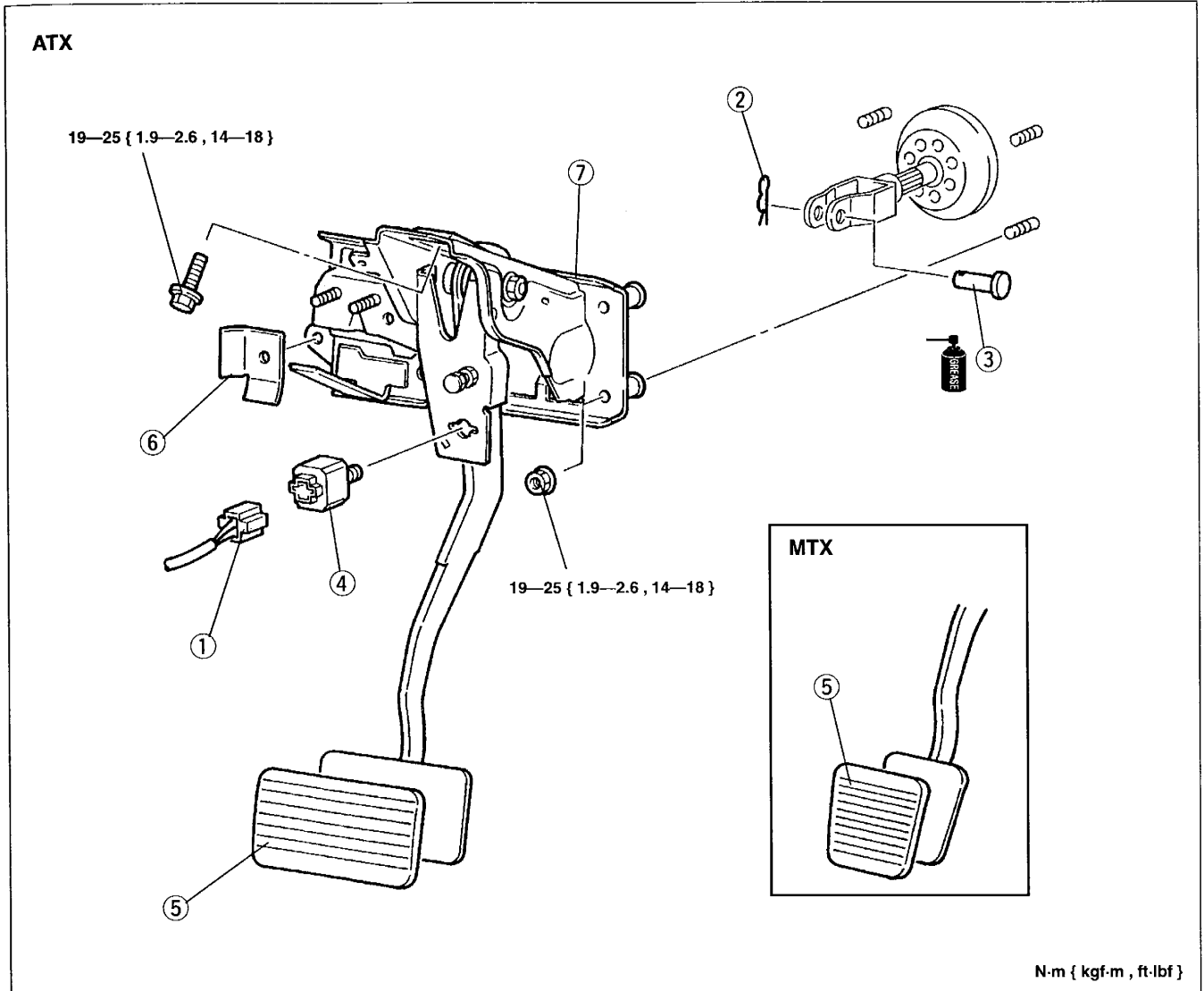

- | | |
|---|--|
| <ul style="list-style-type: none"> 1. Brake switch connector 2. Snap pin 3. Clevis pin 4. Brake switch
Inspection below | <ul style="list-style-type: none"> 5. Pedal pad
Inspect for wear and damage 6. Plate 7. Brake pedal assembly
Inspect for bending and damage |
|---|--|

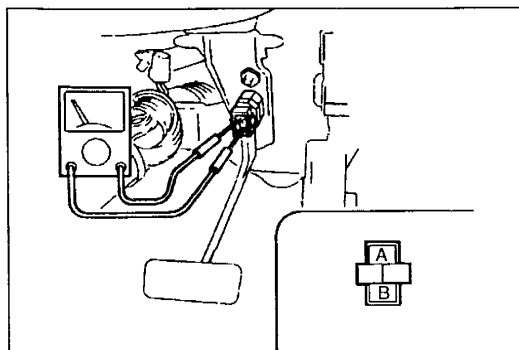

Inspection

Brake switch

1. Disconnect the brake switch connector.
2. Connect an ohmmeter between terminals A and B of the brake switch.
3. Confirm continuity between the terminals when the brake pedal is depressed.

MASTER CYLINDER
Removal / Installation

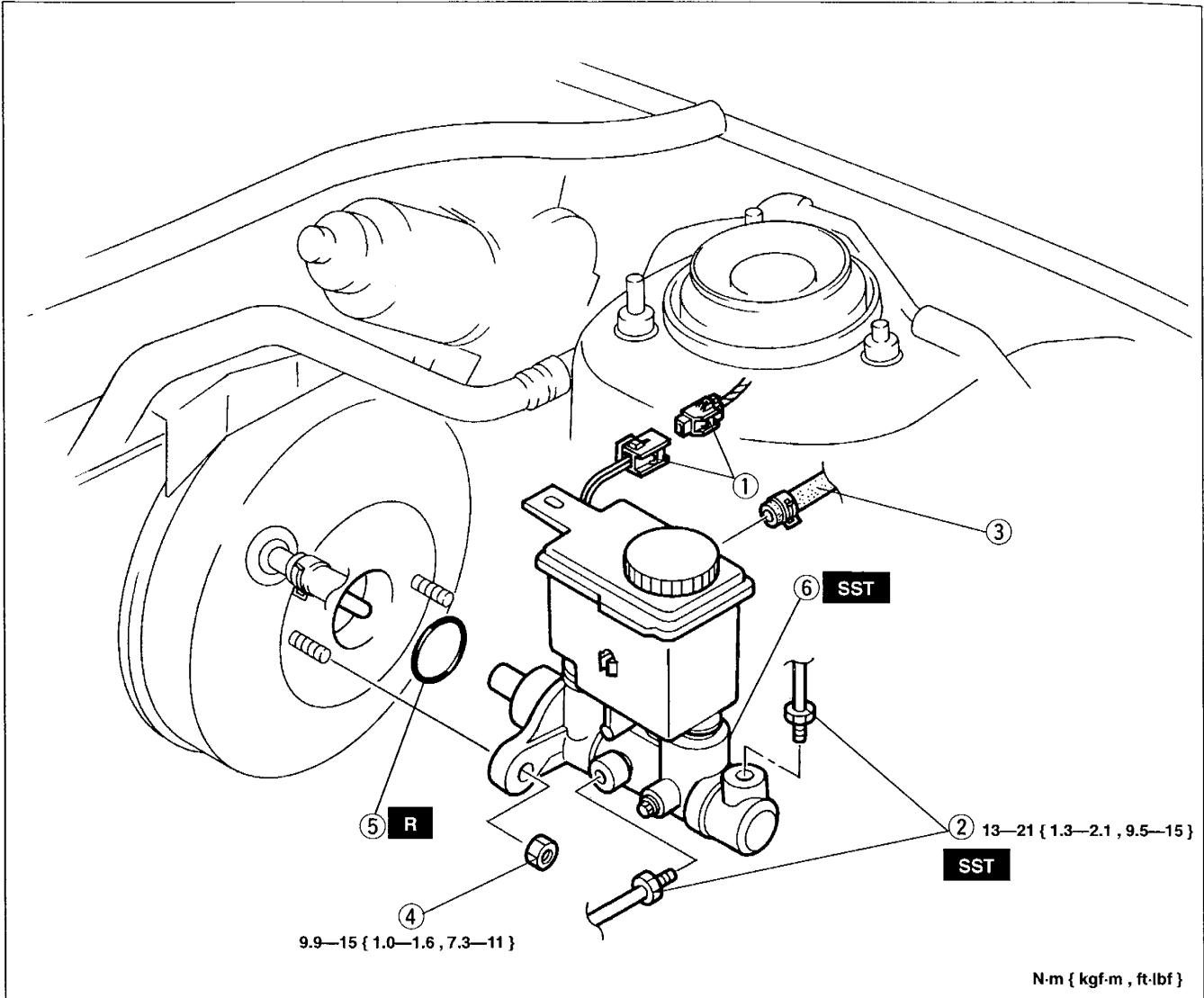

- 1. Brake fluid level sensor connector
- 2. Brake pipe
- 3. Hose (MTX)
- 4. Nut

- 5. O-ring (ABS model)
 - 6. Master cylinder
- Disassembly / Inspection /
Assembly page P-11
Installation Note below

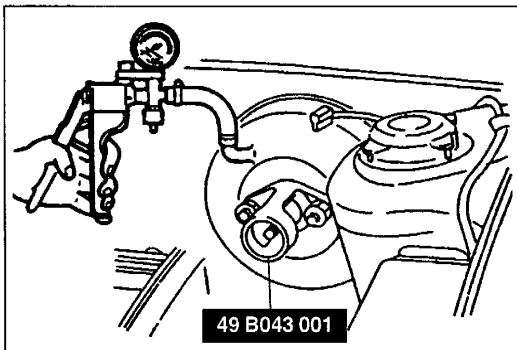

Installation Note

Master cylinder

Piston to push rod clearance

1. Turn the nut of the **SST** clockwise to fully retract the **SST** gauge rod. Attach the **SST** to the power brake unit.

Tightening torque:

9.8—15 N·m { 1.0—1.6 kgf·m , 7.2—11 ft·lbf }

2. Apply **66.7 kPa { 500 mmHg , 19.7 inHg }** vacuum using a vacuum pump.

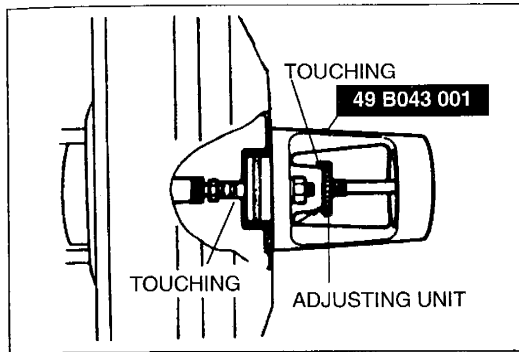

- Turn the adjusting nut of the **SST** counterclockwise until the gauge rod just contacts the push rod end of the power brake unit.
Push lightly on the end of the gauge rod to be sure it is seated. Verify that there is no gap between the adjusting nut and **SST** body.

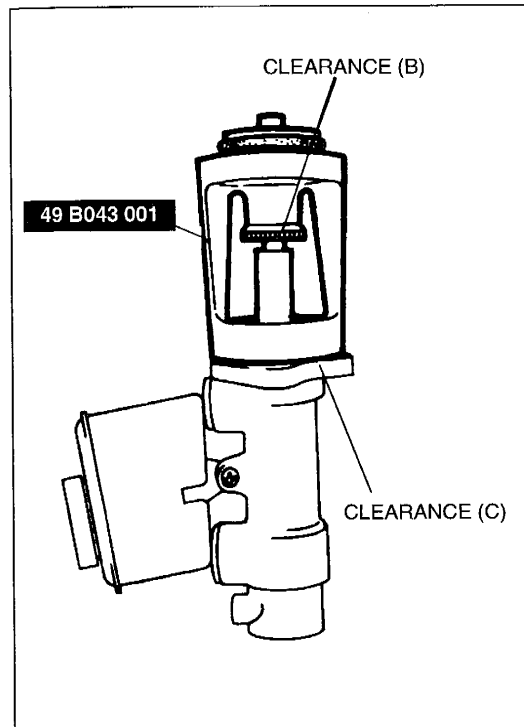

- Remove the **SST** from the power brake unit without disturbing the adjusting nut. Set the **SST** onto the master cylinder as shown in the figure.
- Push lightly on the end of the **SST** gauge rod to be sure it is bottomed in the master cylinder piston, but do not push so hard that the piston moves. Note any clearance between the **SST** body and the adjusting nut (clearance B) or between the body and the master cylinder (clearance C). Adjust the push rod as necessary as outlined in "Adjustment" below.

Measurement	Push rod
Clearance at (B)	Too short
Clearance at (C)	Too long
No clearance at (B) or (C)	OK

P

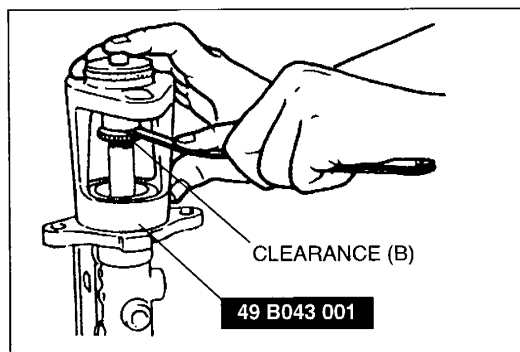

Adjustment

The threads of the push rod are specially designed so that the bolt becomes harder to turn past a certain point. This is to prevent the bolt from coming loose. Turn the bolt only within this range when adjusting.

Clearance at B

- Push lightly on the end of the **SST** gauge rod, and measure the clearance between the adjusting nut and the **SST** body.
- Using the **SSTs**, turn the nut to lengthen the power brake unit push rod to an amount equal to the clearance measured at B.

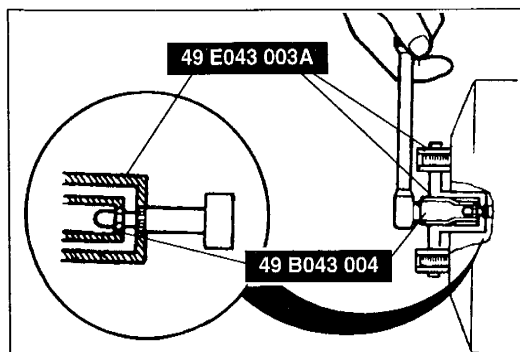

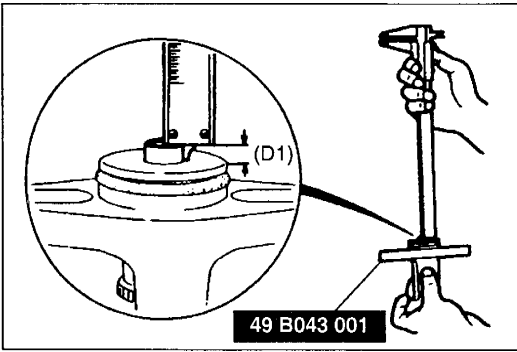

Clearance at C

1. Measure and record height D1 of the gauge rod.

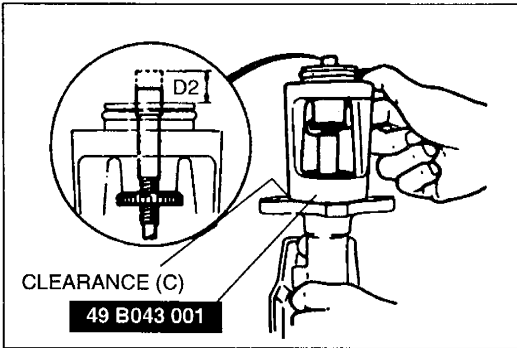

2. Turn the adjusting nut until the **SST** body sets squarely on the master cylinder. (Turn only enough for the body to touch.)

3. Measure and record height D2 of the gauge rod.

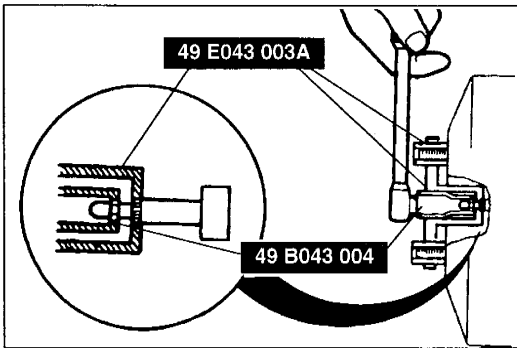

4. Subtract D1 from D2 and using the **SST**, turn the nut to shorten the power brake unit push rod an amount equal to the sum.

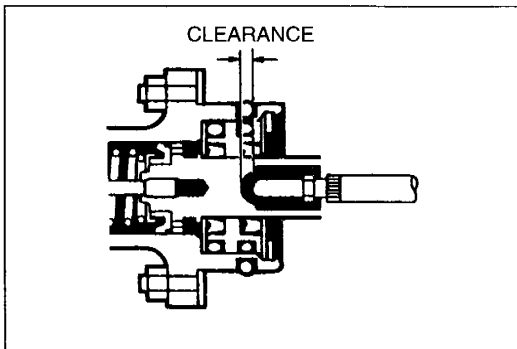

Note

- This adjustment produces the following clearance.

Vacuum applied to unit	Push rod to piston clearance
Approx. 66.7 kPa { 500 mmHg , 19.7 inHg }	0.1—0.4 mm { 0.0039—0.0157 in }

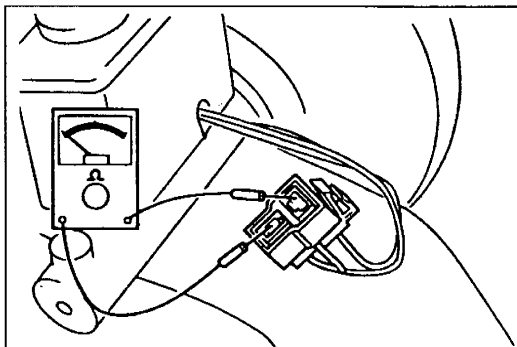

Inspection

Fluid level sensor

1. Disconnect the sensor connector.
2. Connect an ohmmeter to the connector.
3. Starting with the fluid level above MIN, verify that there is no continuity.
4. Remove the brake fluid and verify continuity when the level is below MIN.
5. Replace the sensor if necessary.

Disassembly / Inspection / Assembly

Caution

- The brake master cylinder is made of aluminum, and can be easily damaged by tightening in a vise. When securing the master cylinder in a vise, tighten only the flange of the master cylinder.

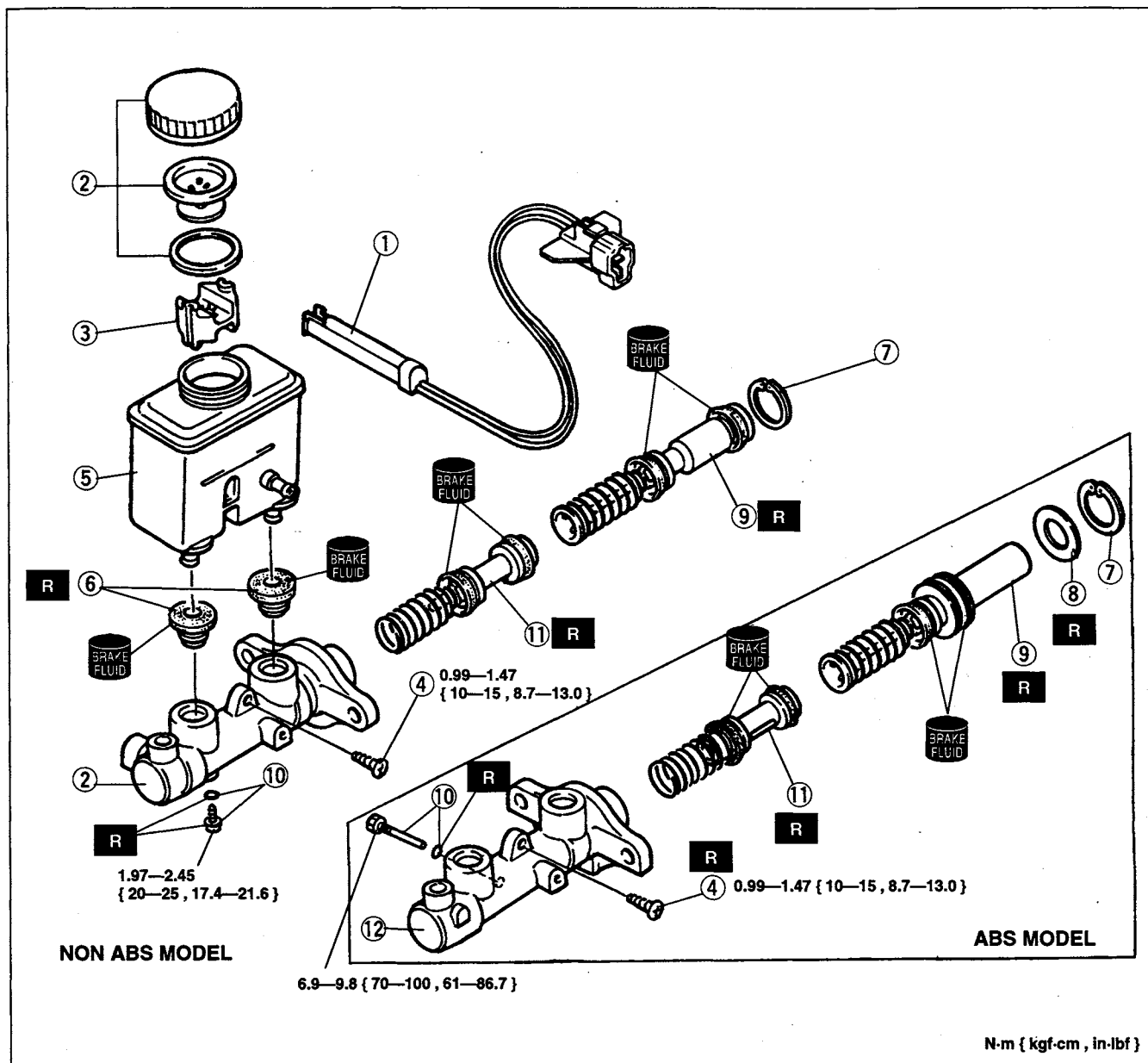

- | | |
|--|--|
| <ol style="list-style-type: none"> 1. Fluid level sensor
Inspection page P-10 2. Cap set 3. Filter 4. Screw 5. Reservoir
Inspect for damage and deformation 6. Bushings 7. Snap ring 8. Spacer | <ol style="list-style-type: none"> 9. Primary piston assembly
Inspect for abnormal wear, rust, and damage 10. Stop screw and O-ring (Non ABS model)
Assembly Note page P-12 10. Stop pin and O-ring (ABS model)
Assembly Note page P-12 11. Secondary piston assembly
Inspect for abnormal wear, rust, and damage 12. Master cylinder body
Inspect inside of body for corrosion |
|--|--|

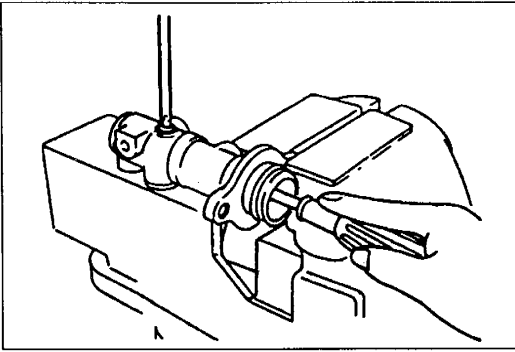
**Assembly note****Stop screw and O-ring (Non ABS model)**

1. Push the secondary piston assembly in fully.
2. Install and tighten a new O-ring and stop screw.
3. Push and release the piston to verify that it is held by the stop screw.

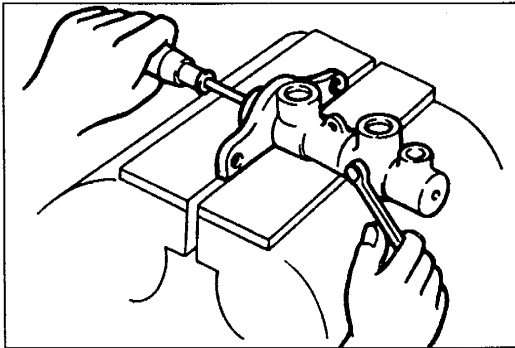
**Stop pin and O-ring (ABS model)**

1. Install the secondary piston assembly with the piston hole facing the stop pin.
2. Install and tighten a new O-ring and stop pin.
3. Push and release the piston to verify that it is held by the stop pin.

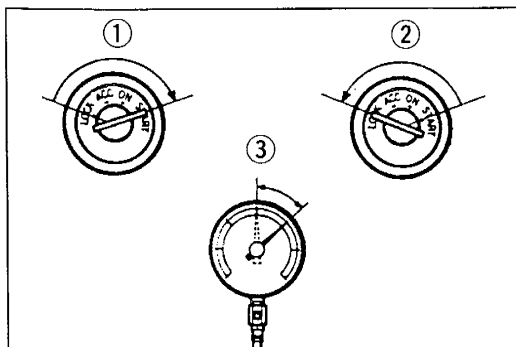
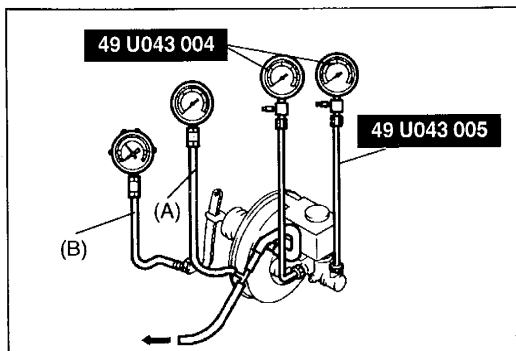
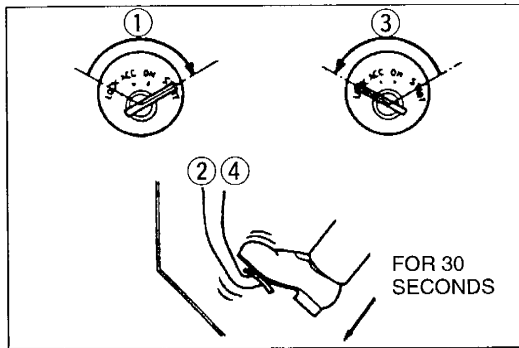
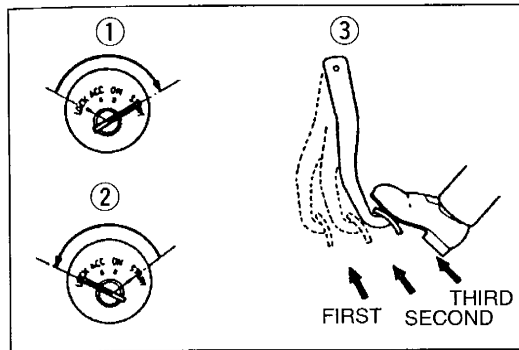
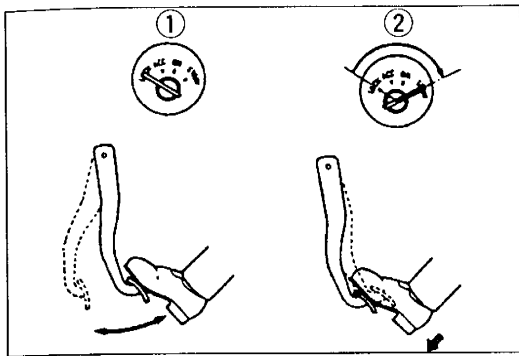

POWER BRAKE UNIT

Quick Inspection (on-vehicle)

Power brake unit function check (simple method)

Step 1

1. With the engine stopped, depress the pedal a few times.
2. With the pedal depressed, start the engine.
3. If the pedal moves down slightly immediately after the engine starts, the unit is operating.

Step 2

1. Start the engine.
2. Stop the engine after it has run for **1 or 2 minutes**.
3. Depress the pedal with the usual force.
4. If the first pedal stroke is long and becomes shorter with subsequent strokes, the unit is operating.
5. If a problem is found, inspect the check valve and vacuum hose for damage and examine the installation. Repair if necessary, and inspect it again.

Step 3

1. Start the engine.
2. Depress the pedal with the usual force.
3. Stop the engine with the pedal depressed.
4. Hold the pedal down for **about 30 seconds**.
5. If the pedal height does not change, the unit is operating.
6. If there is a problem, inspect the check valve and vacuum hose for damage, and inspect the connection. Repair if necessary and inspect again.

If the nature of the problem is still not clear after the 3 steps above, follow the more detailed inspection described in "Inspection using gauges" below.

(Inspection using gauges)

Connect the **SST** gauges, vacuum gauge (A), and pedal depression force gauge (B) as shown. Bleed the air from the **SST** gauges before performing the following tests.

a) Checking for vacuum loss

Unloaded condition

1. Start the engine.
2. Stop the engine when the vacuum gauge reading reaches **66.6 kPa { 500 mmHg , 19.6 inHg }**.
3. Observe the vacuum gauge for **15 seconds**. If the gauge shows **63.4—66.6 kPa { 475—500 mmHg , 18.8—19.6 inHg }**, the unit is operating.

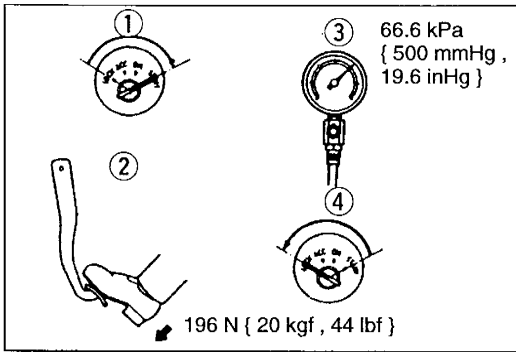

Loaded condition

1. Start the engine.
2. Depress the brake pedal with a force of **196 N { 20 kgf, 44 lbf }**.
3. With the brake pedal depressed, stop the engine when the vacuum gauge reading reaches **66.6 kPa { 500 mmHg, 19.6 inHg }**.
4. Observe the vacuum gauge for **15 seconds**. If the gauge shows **63.4—66.6 kPa { 475—500 mmHg, 18.8—19.6 inHg }**, the unit is operation.

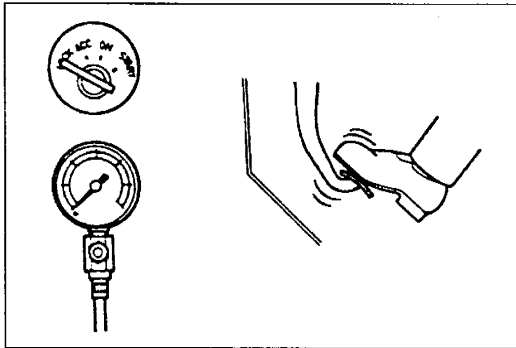

b) Checking for hydraulic pressure

1. With the engine stopped (vacuum **0 kPa { 0 mmHg, 0 inHg }**), depress the brake pedal with a force of **196 N { 20 kgf, 44 lbf }**. If the fluid pressure is within specification, the unit is operating.

Fluid pressure

MTX: 981 kPa { 10 kgf/cm², 143 psi } min.
ATX: 883 kPa { 9 kgf/cm², 128 psi } min.

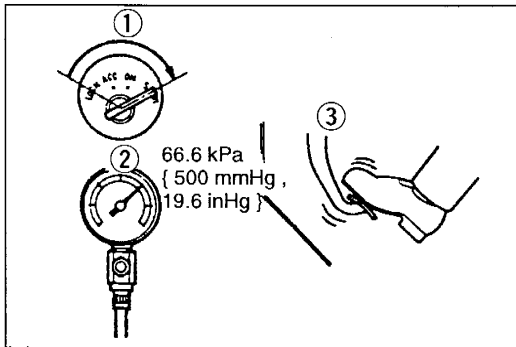

2. Start the engine. Depress the brake pedal with a force of **196 N { 20 kgf, 44 lbf }** when the vacuum reaches **66.6 kPa { 500 mmHg, 19.6 inHg }**. If the fluid pressure is within the specification, the unit is operating.

Fluid pressure

MTX: 7,160 kPa { 73 kgf/cm², 1039 psi } min.
ATX: 8,240 kPa { 84 kgf/cm², 1195 psi } min.

Removal / Installation

- Remove the battery.
- Take the following steps after installation.
 - (1) Adjust the brake pedal. (Refer to page P-6.)
 - (2) Make an on-vehicle check of the unit. (Refer to page P-13.)

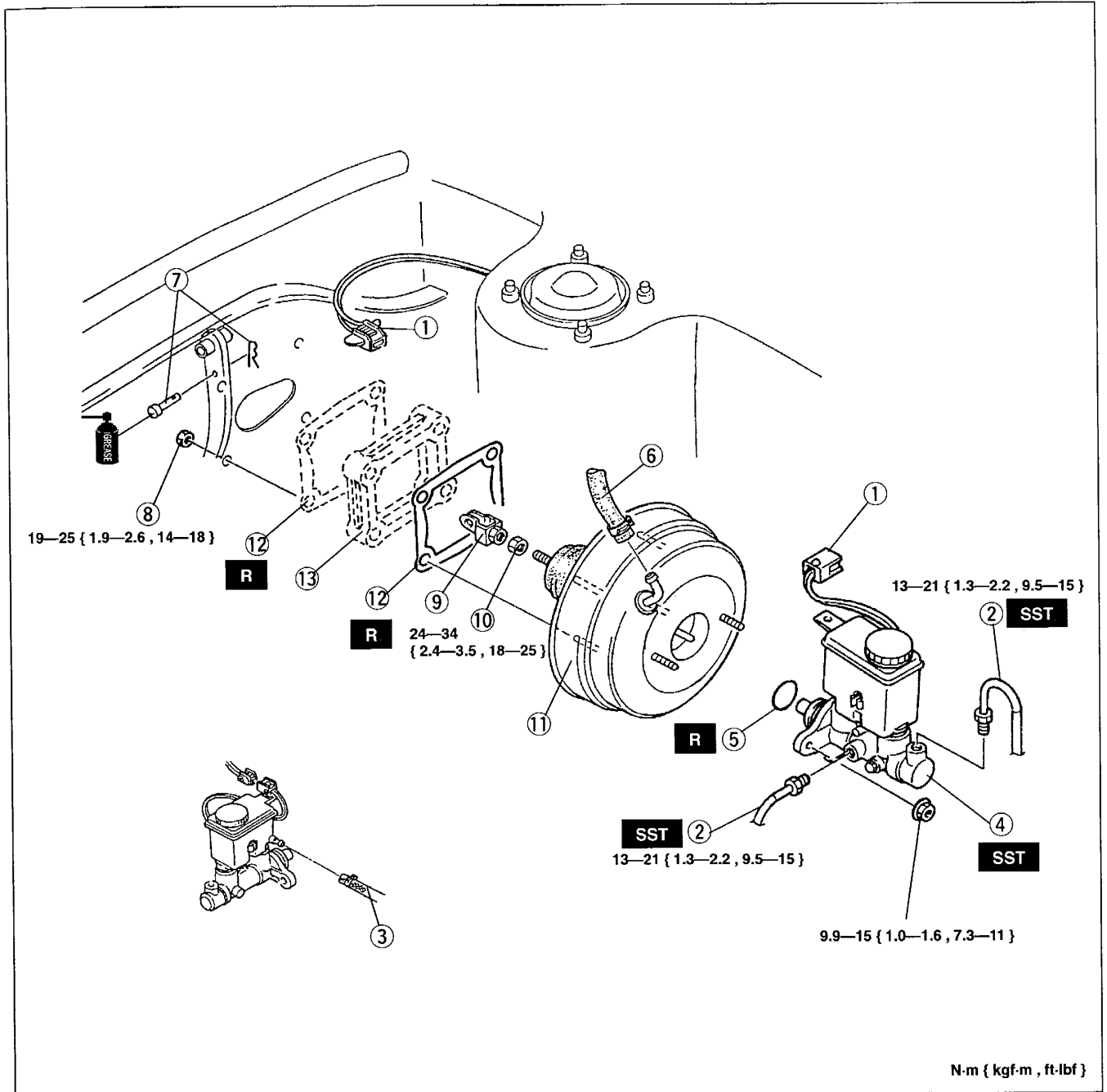

- | | |
|---------------------------------------|----------------------------|
| 1. Brake fluid level sensor connector | 7. Snap pin and clevis pin |
| 2. Brake pipe | 8. Nut |
| 3. Hose (MTX) | 9. Fork |
| 4. Master cylinder | 10. Nut |
| Installation Note page P-8 | 11. Power brake unit |
| 5. O-ring (ABS model) | 12. Gasket |
| 6. Vacuum hose | 13. Spacer (MTX) |

N-m { kgf-m , ft-lbf }

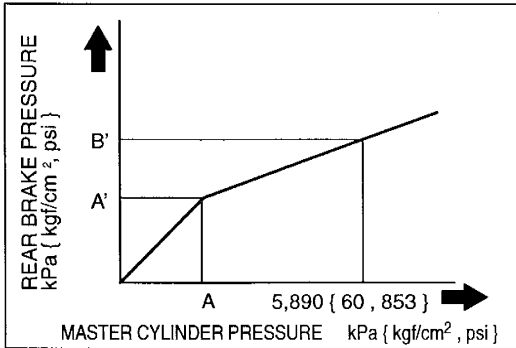
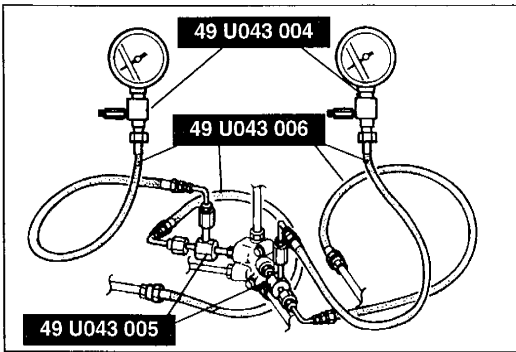

DUAL PROPORTIONING VALVE

Inspection

1. Connect the **SSTs** to the brake pipes by using the adapters as shown in the figure.

Adapter and flare nut tightening torque:

13—21 N·m { 1.3—2.2 kgf·m , 9.5—15 ft·lbf }

2. Bleed the air from the brake system. (Refer to page P-5.)
3. Depress the brake pedal until the master cylinder pressure equals A ; then record rear brake pressure A'.
4. Depress the brake pedal again, and apply additional pressure until the pressure reaches **5,890 kPa { 60 kgf/cm² , 853 psi }**. Then record pressure B'.

Fluid pressure

kPa { kgf/cm² , psi }

	Z5 engine non-ABS	BP engine non-ABS	Z5, BP engine with ABS
A	1,960 { 20 , 284 }	2,450 { 25 , 356 }	2,450 { 25 , 356 }
A'	1,960 { 20 , 280 } ± 196 { 2 , 28 }	2,450 { 25 , 356 } ± 196 { 2 , 28 }	2,450 { 25 , 356 } ± 196 { 2 , 28 }
B'	2,750 { 28 , 398 } ± 196 { 2 , 28 }	3,460 { 35.5 , 505 } ± 294 { 3 , 43 }	3,820 { 39 , 555 } ± 294 { 3 , 43 }

5. If not within specification, replace the dual proportioning valve.

Replacement

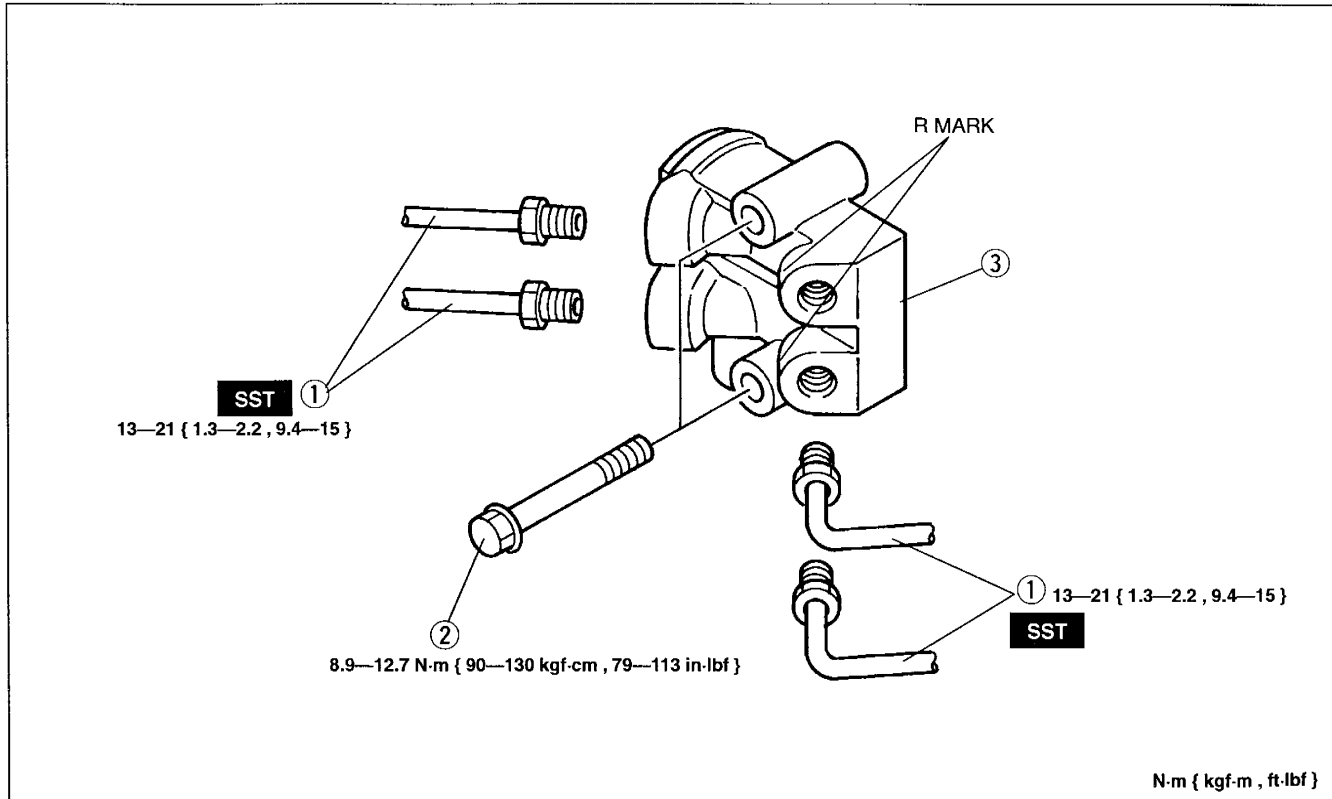

1. Brake pipe
2. Bolt

3. Dual proportioning valve

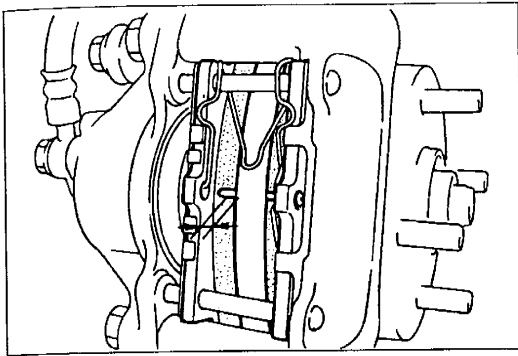

**FRONT BRAKE (DISC)
Inspection (On-vehicle)**

Disc pad

1. Jack up the front of the vehicle and support it with safety stands.
2. Remove the wheel and tires.
3. Verify the remaining thickness of the pads.

Thickness: 1.0 mm { 0.039 in } min.

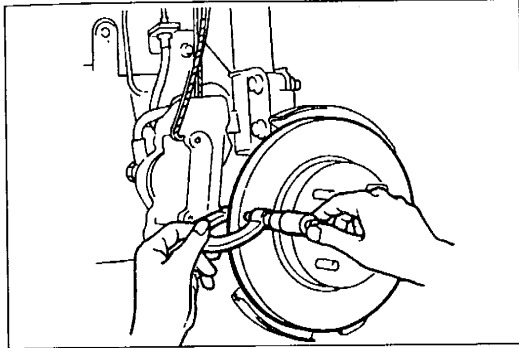

Disc plate thickness

1. Measure the thickness of the disc plate.

Caution

- When it is necessary to machine the disc plate, if the disc plate is removed from the vehicle then machined, excessive runout may result. Machine the disc plate with it installed on the vehicle.

Standard : 22 mm { 0.8661 in }

Minimum : 20 mm { 0.7874 in }

**Minimum thickness after machining by using a
brake lathe on-vehicle
: 20.8 mm { 0.8189 in }**

2. If the thickness is not within the specification, replace the disc plate.

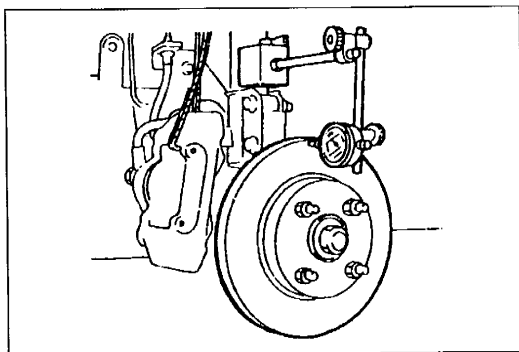

Disc plate runout

1. Verify that there is no wheel bearing looseness. (Refer to section M.)
2. Measure the runout at the outer edge of the contact surface of the disc pad.

Runout: 0.05 mm { 0.002 in } max.

3. If the runout is not within the specification, repair or replace the disc plate.

Removal / Inspection / Installation

- After installation, depress the pedal a few times. Then rotate the wheel by hand, and verify that the brakes do not drag.

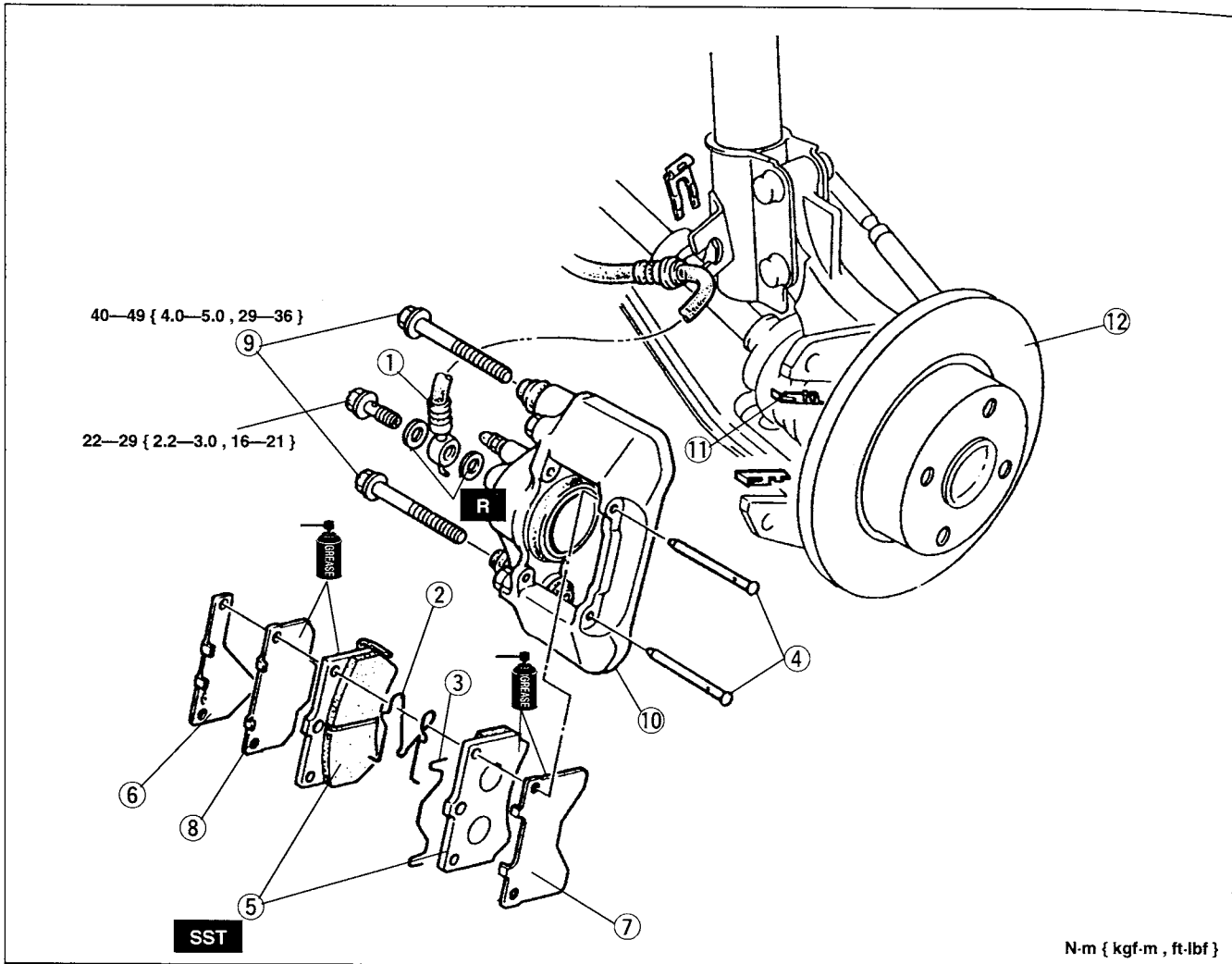

- | | |
|---|--|
| 1. Flexible hose | 7. Outer shim |
| 2. M-spring | 8. Inner shim |
| 3. W-clip | 9. Bolt |
| 4. Pad pin | 10. Caliper |
| 5. Disc pad | Disassembly / Inspection /
Assembly page P-20 |
| Inspection (on-vehicle) page P-17 | 11. Guide plate |
| Replacement page P-19 | 12. Disc plate |
| Installation Note below | Inspection (on-vehicle) page P-17 |
| 6. Anti-squeak shim | |

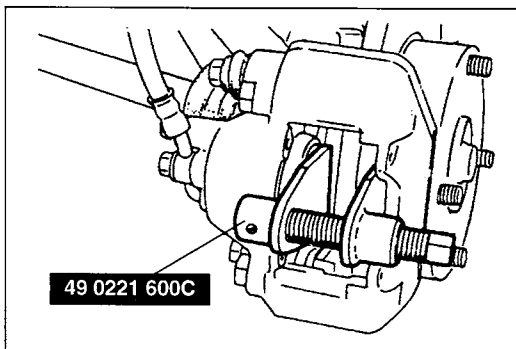

Installation note

Disc pad

1. Push the piston fully inward by using the SST.
2. Install the disc pad.

DISC PAD (FRONT)
Replacement

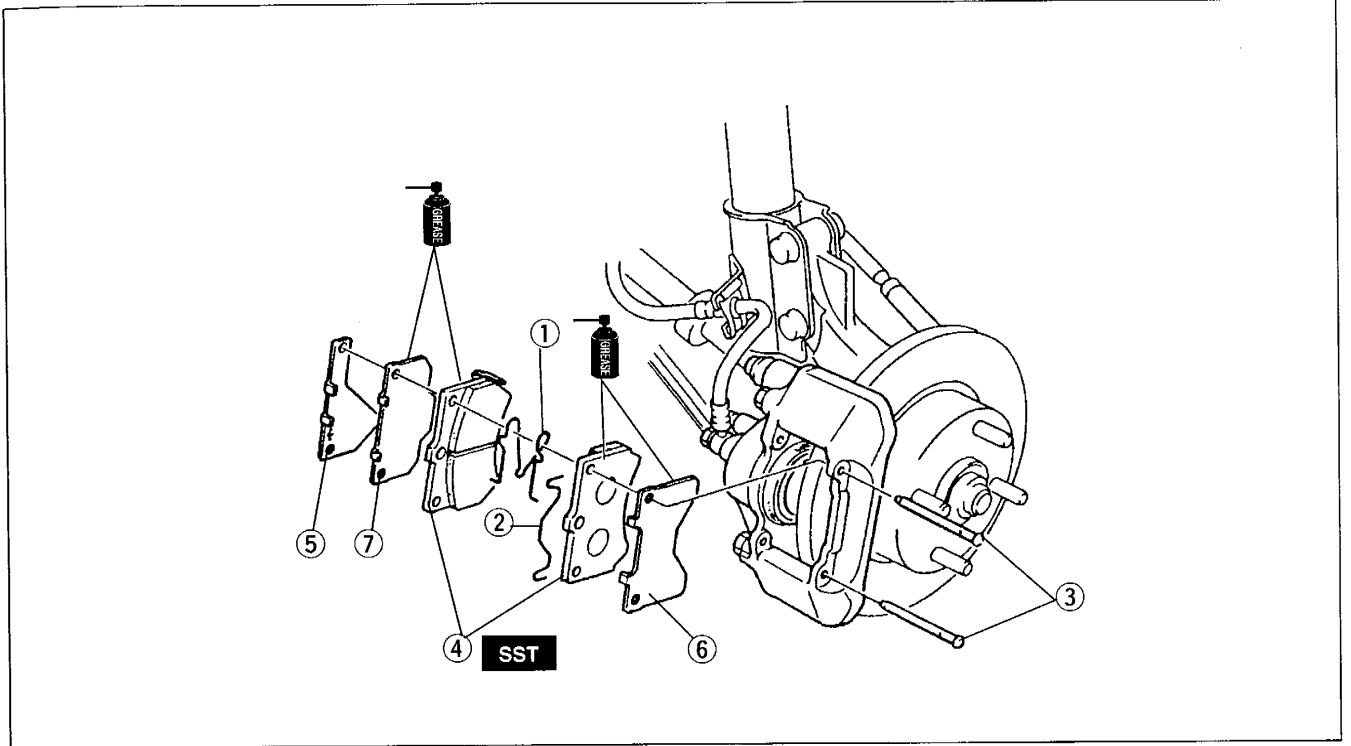

- 1. M-spring
- 2. W-clip
- 3. Pad pin
- 4. Disc pad
- 5. Anti-squeak shim
- 6. Outer shim
- 7. Inner shim

Inspection (on-vehicle) page P-17
Installation Note page P-18

CALIPER (FRONT)

Disassembly / Inspection / Assembly

- If the piston or the caliper body is damaged, replace the caliper as an assembly.

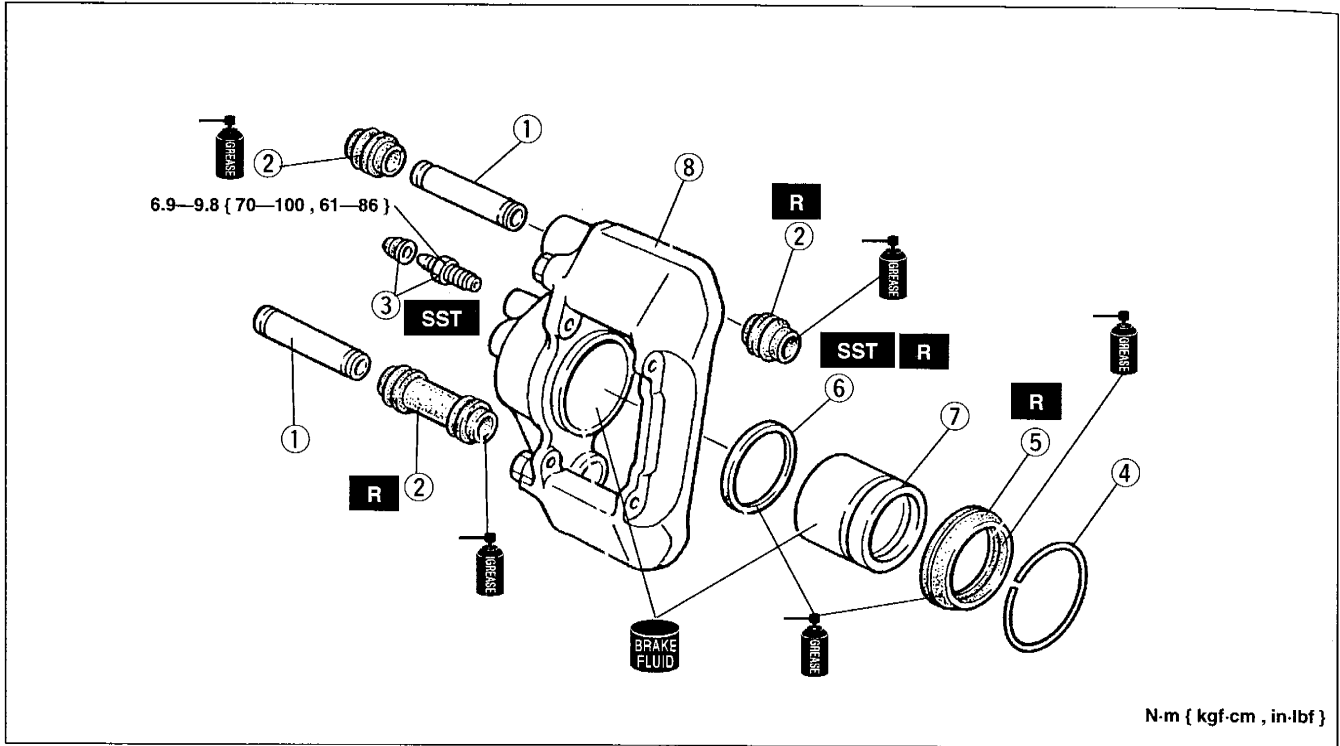

1. Sleeve
2. Boot
3. Bleeder cap, bleeder screw
4. Retaining ring
5. Dust seal
6. Piston seal

7. Piston
Disassembly Note below
Inspect for damage, wear, and rust
8. Caliper body
Inspect for damage, cracks, and rust

Disassembly Note below

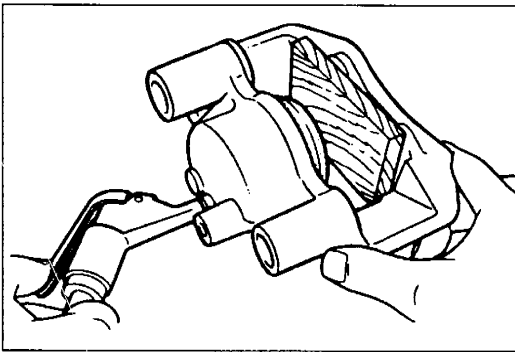

Disassembly note

Piston

1. Place a piece of wood in the caliper.
2. Gently blow compressed air through the pipe hole to force the piston out of the caliper.

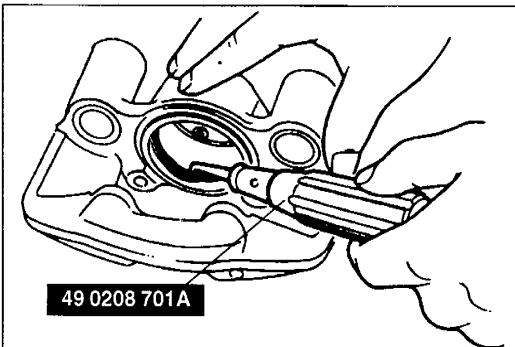

Piston seal

Remove the piston seal from the caliper by using the SST.

49 0208 701A

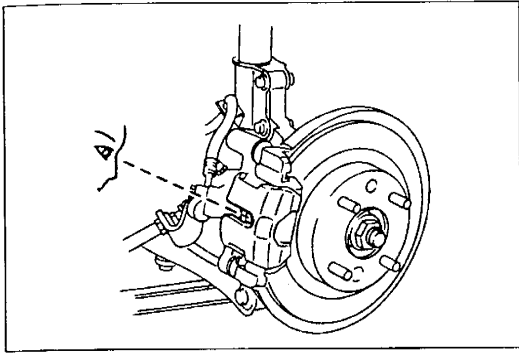

**REAR BRAKE (DISC)
Inspection (On-vehicle)
Disc pad**

1. Jack up the rear of the vehicle and support it with safety stands.
2. Remove the wheel and tires.
3. Verify the remaining thickness of the pads.

Thickness: 1.0 mm { 0.039 in } min.

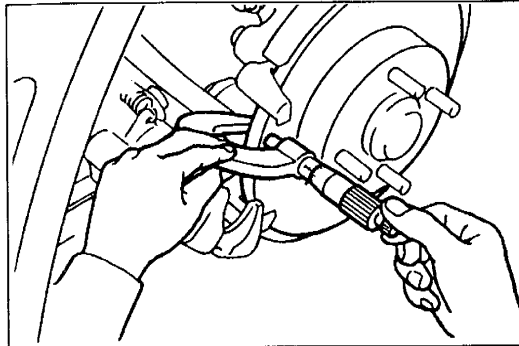

Disc plate thickness

1. Measure the thickness of the disc plate.

Caution

- When it is necessary to machine the disc plate, if the disc plate is removed from the vehicle then machined, excessive runout may result. Machine the disc plate with it installed on the vehicle.

Standard: 9 mm { 0.3543 in }

Minimum: 7 mm { 0.2756 in }

**Minimum thickness after machining by using a
brake lathe on-vehicle
: 7.8 mm { 0.3071 in }**

2. If the thickness is not within the specifications, replace the disc plate.

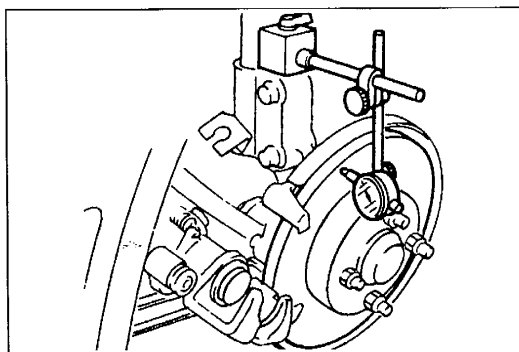

Disc plate runout

1. Verify that there is no looseness in the wheel bearing. (Refer to section M.)
2. Measure the runout at the outer edge of the contact surface of the disc pad.

Runout: 0.5 mm { 0.002 in } max.

3. If the runout is not within the specification, repair or replace the disc plate.

Removal / Inspection / Installation

- After installation, depress the pedal a few times. Then rotate the wheel by hand and verify that the brakes do not drag.

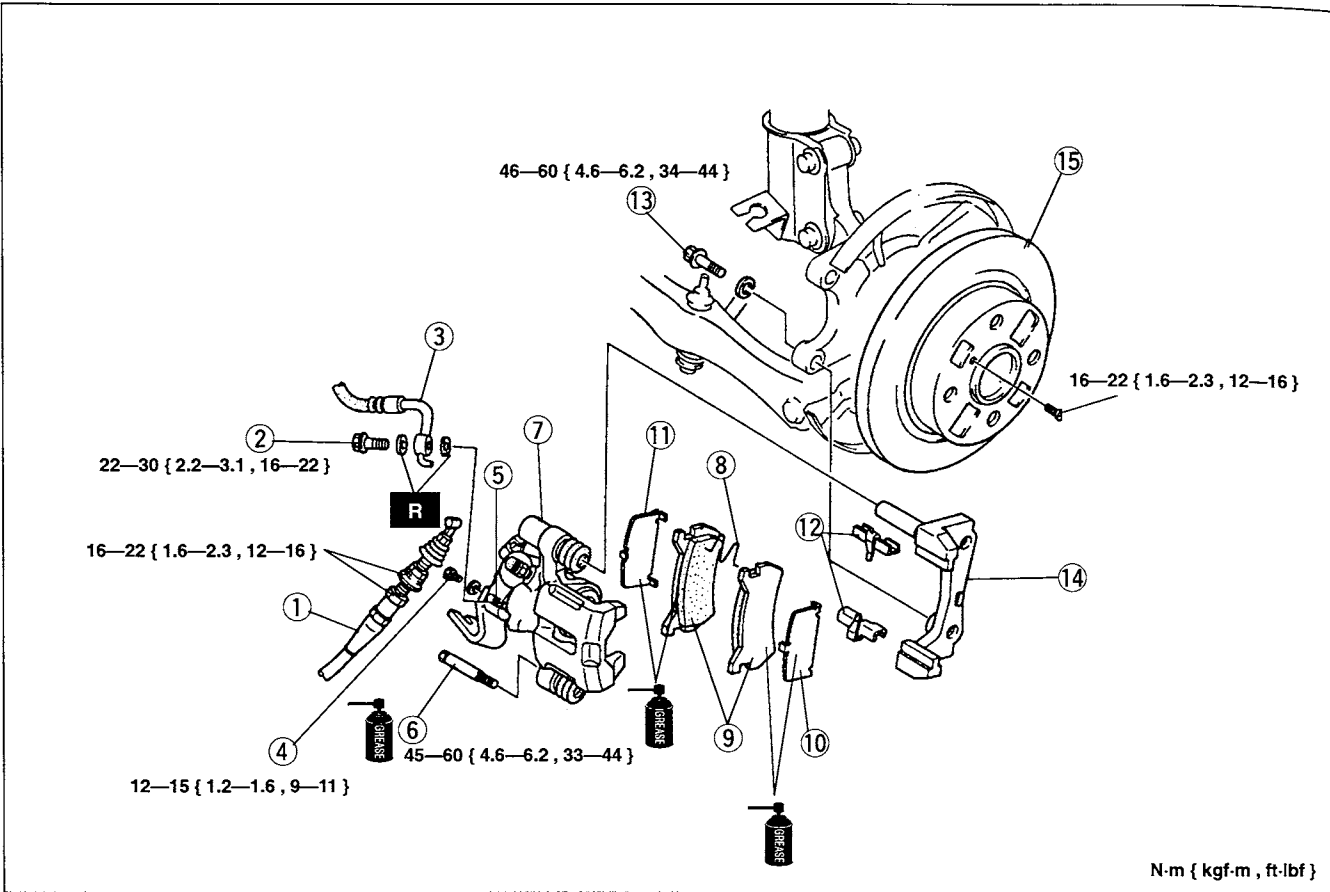

- | | |
|---|--|
| <p>1. Parking cable, clip
Removal / Inspection /
Installation page P-29</p> <p>2. Connecting bolt</p> <p>3. Brake hose</p> <p>4. Screw plug</p> <p>5. Manual adjustment gear
Removal Note below
Installation Note page P-23</p> <p>6. Lock bolt</p> <p>7. Caliper
Disassembly / Inspection /
Assembly page P-24</p> | <p>8. M-spring</p> <p>9. Disc pad
Inspection (on-vehicle) page P-21
Replacement page P-23</p> <p>10. Outer shim</p> <p>11. Inner shim</p> <p>12. Guide plate</p> <p>13. Bolt</p> <p>14. Mounting support</p> <p>15. Disc plate
Inspection (on-vehicle) page P-21</p> |
|---|--|

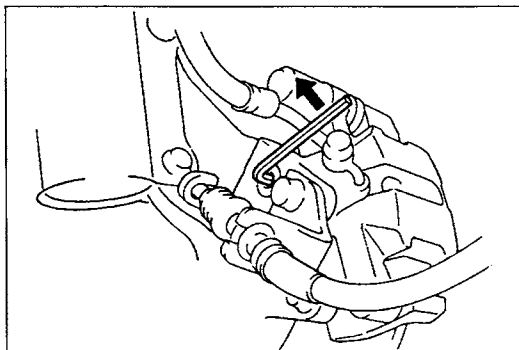

Removal note

Manual adjustment gear

Turn the manual adjustment gear counterclockwise by using an Allen wrench to pull the brake caliper piston inward. (Turn until it stops.)

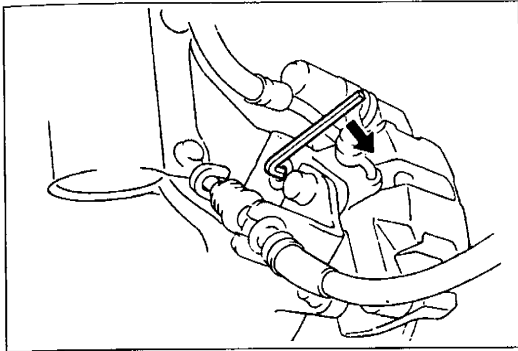

Installation note
Manual adjustment gear

1. Turn the manual adjustment gear clockwise until the brake pads just touch the disc plate.
2. Return the manual adjustment gear 1/3-turn.

DISC PAD (REAR)
Replacement

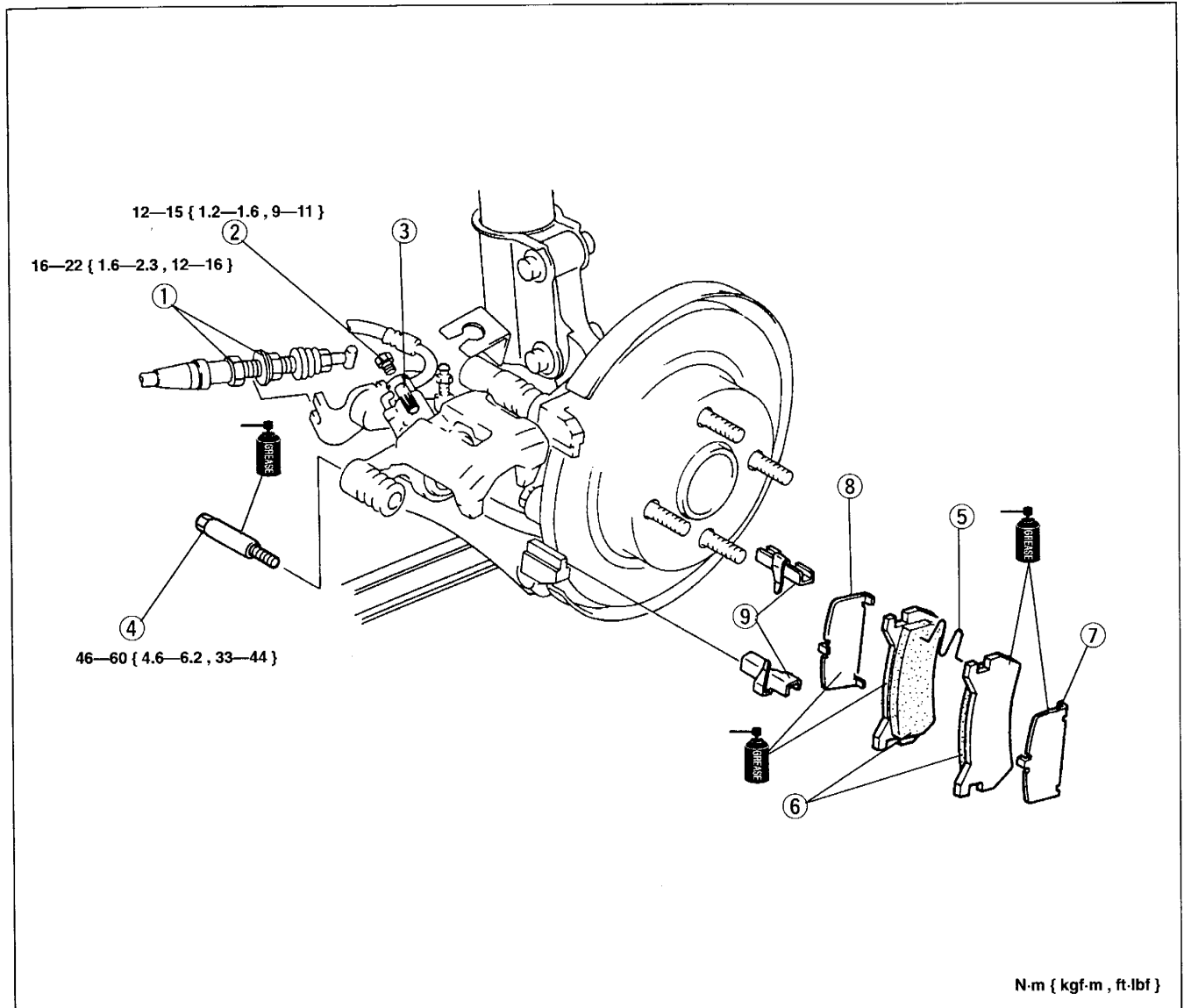

- | | | |
|--|---|--|
| <ol style="list-style-type: none"> 1. Parking brake cable, clip 2. Screw plug 3. Manual adjustment gear 4. Lock bolt | Removal Note page P-22
Installation Note above | <ol style="list-style-type: none"> 5. M-spring 6. Disc pad 7. Outer shim 8. Inner shim 9. Guide plate |
|--|---|--|

CALIPER (REAR)

Disassembly / Inspection / Assembly

- If the piston or the caliper body is damaged, replace the caliper as an assembly.

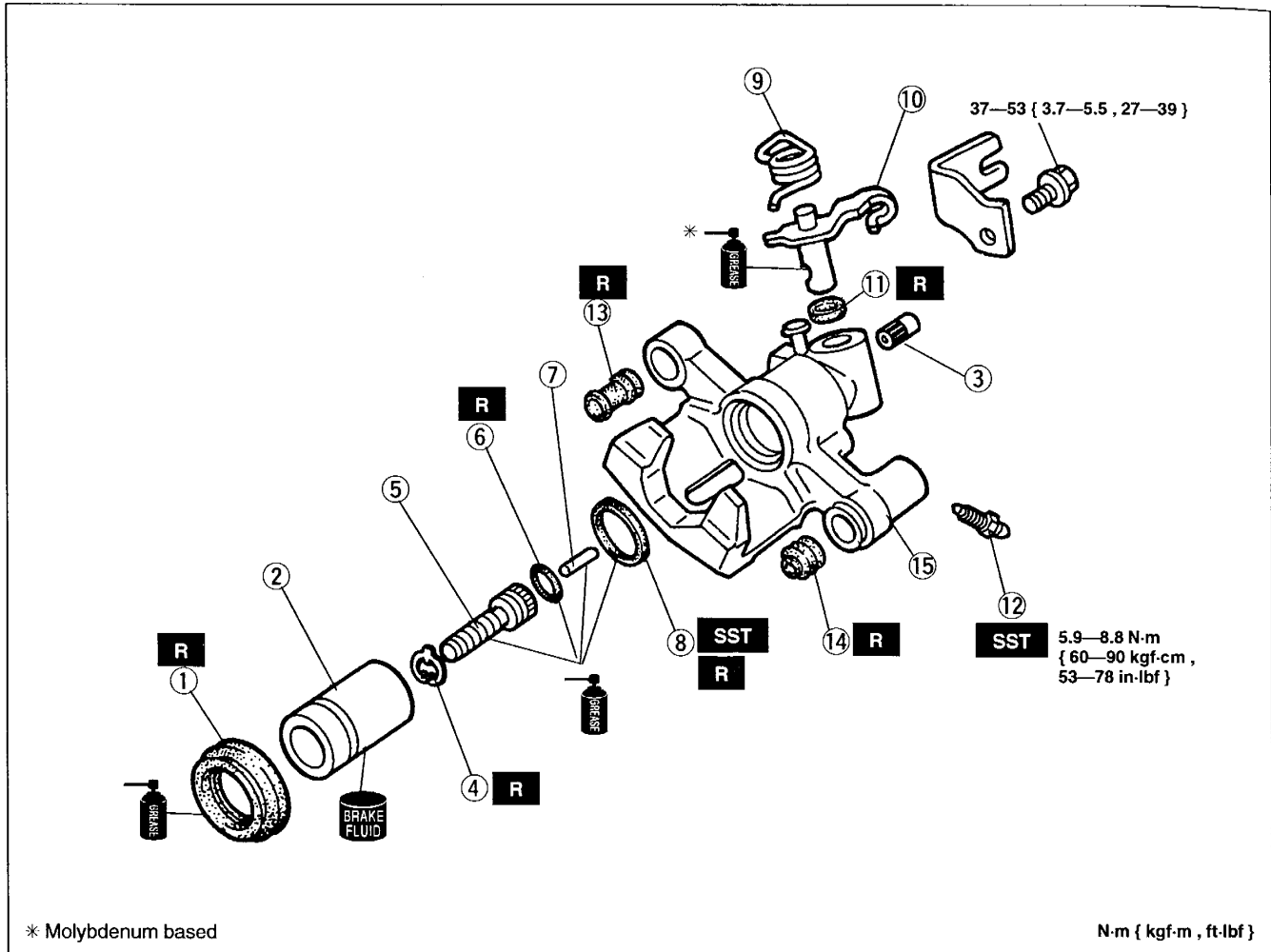

- | | |
|--|---|
| <p>1. Dust seal</p> <p>2. Piston
Disassembly Note below
Assembly Note page P-25
Inspect for wear and rust</p> <p>3. Manual adjustment gear</p> <p>4. Snap ring</p> <p>5. Adjusting bolt</p> <p>6. O-ring</p> <p>7. Connecting link</p> | <p>8. Piston seal
Disassembly Note page P-25</p> <p>9. Spring</p> <p>10. Operating lever</p> <p>11. Boot</p> <p>12. Bleeder cap and bleeder screw</p> <p>13. Boot</p> <p>14. Boot</p> <p>15. Caliper body
Inspect for damage and cracks</p> |
|--|---|

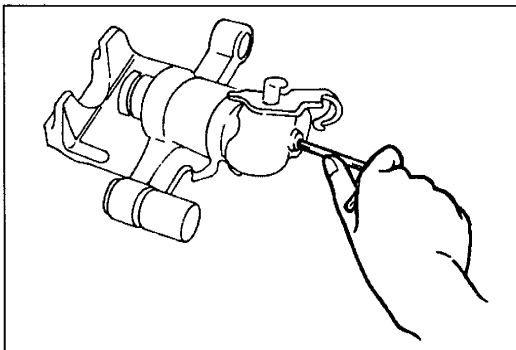

Disassembly note

Piston

Turn the adjustment gear clockwise by using an Allen wrench to remove the piston from the adjustment gear. (Turn the adjustment gear until it becomes easy to turn.)

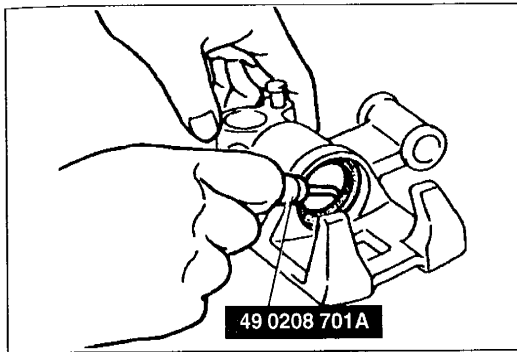

Piston seal

Remove the piston seal from the caliper by using the SST.

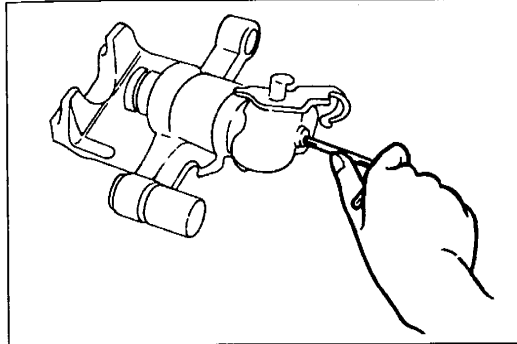

Assembly note

Piston

Insert the piston into the caliper and turn the adjustment gear counterclockwise by using an Allen wrench to pull the piston inward. (Turn until it stops.)

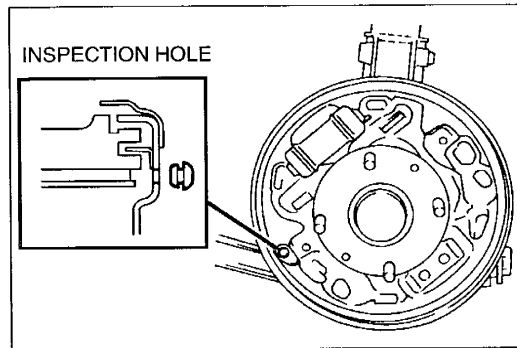

REAR BRAKE (DRUM)

Inspection (On-vehicle)

Brake shoe

1. Jack up the rear of the vehicle and support it with safety stands.
2. Remove the plug as shown in the figure, then inspect the thickness of the brake lining through the inspection hole.
3. Replace if below the limit.

Thickness: 1.0 mm { 0.039 in } min.

Removal / Inspection / Installation

- After installation, check the following.
 - (1) Depress the pedal a few times. Then rotate the wheel by hand and verify that the brakes do not drag.
 - (2) Check the pedal-to-floor clearance. (Refer to page P-6.)
 - (3) Check the parking brake lever stroke. (Refer to page P-28.)

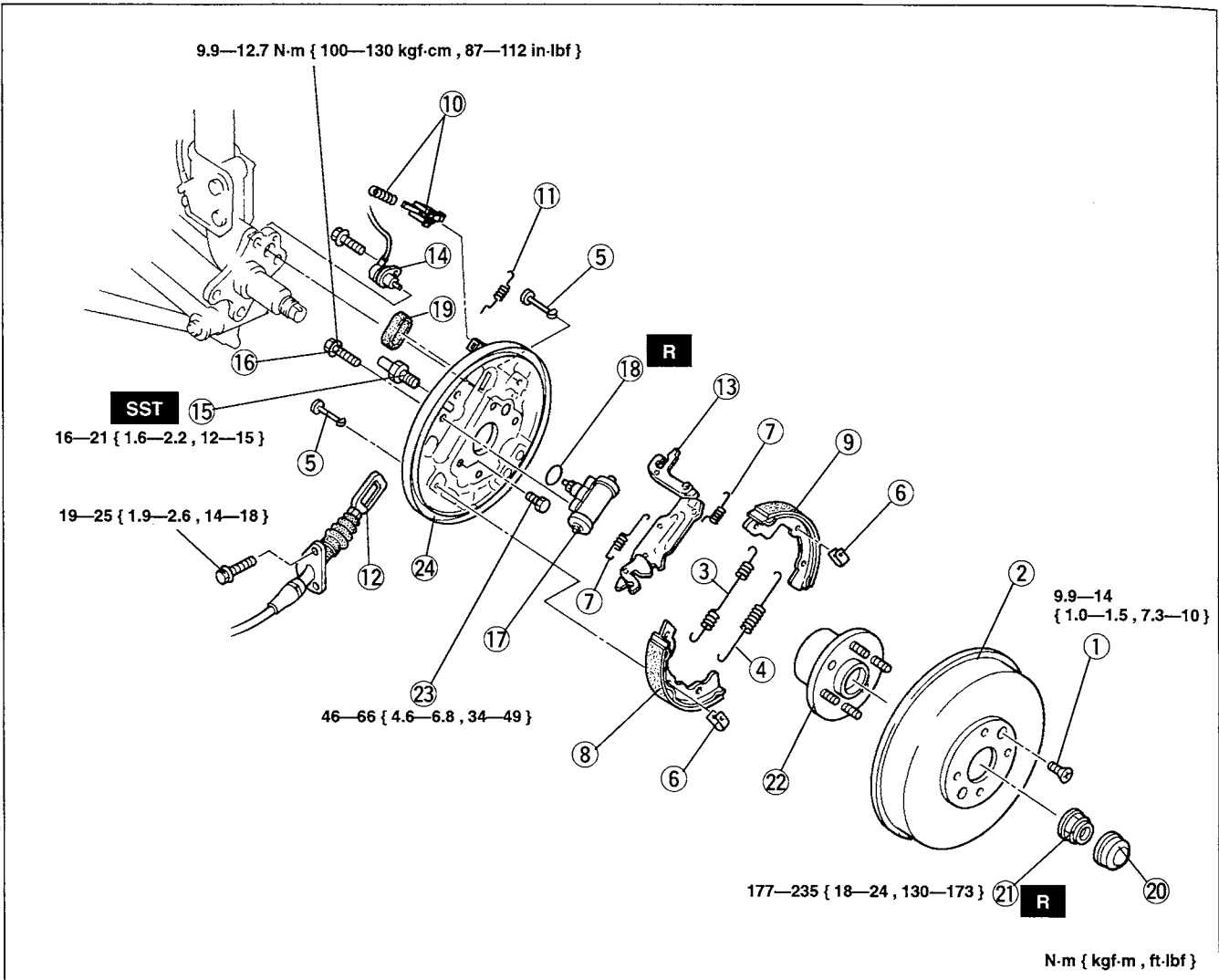

- | | |
|--|---|
| <ol style="list-style-type: none"> 1. Screw 2. Brake drum Removal Note page P-27 Inspection page P-27 Installation Note page P-27 3. Return spring (upper) 4. Return spring (lower) 5. Hold pin 6. Hold spring 7. Anti-rattle spring 8. Brake shoe (leading side) Inspection (on-vehicle) page P-25 9. Brake shoe (trailing side) Inspection (on-vehicle) page P-25 10. Stop spring and clip 11. Spring 12. Parking cable 13. Operating lever assembly | <ol style="list-style-type: none"> 14. ABS wheel-speed sensor Removal / Installation page P-41 Inspection (on-vehicle) page P-40 15. Brake pipe 16. Bolt 17. Wheel cylinder Disassembly / Inspection / Assembly page P-28 18. Wheel cylinder gasket 19. Dust boot 20. Hub cap 21. Locknut Service section M 22. Wheel hub assembly Service section M 23. Bolt 24. Backing plate Inspect for damage and cracks |
|--|---|

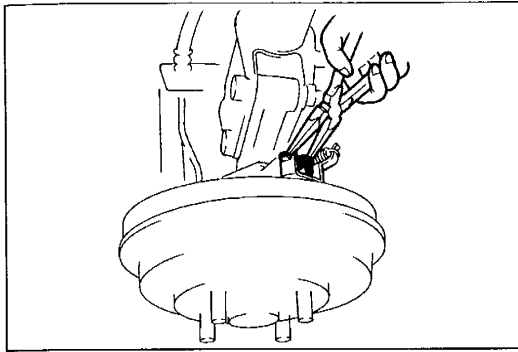

Removal note

Brake drum

If the brake drum is hard to remove, loosen the parking cable nut fully and secure the stopper until the operating lever returns to release the sticking of the brake drum.

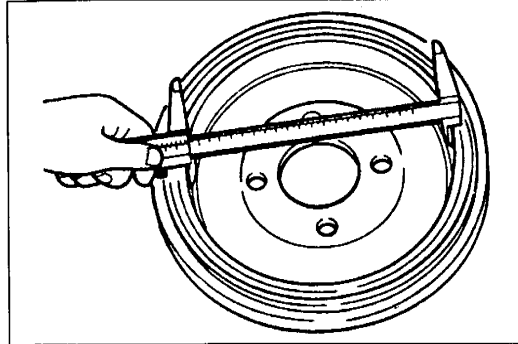

Inspection

Brake drum

Check for the following and repair or replace parts as necessary.

- (1) Drum inner diameter

Diameter limit: 201.5 mm { 7.933 in }

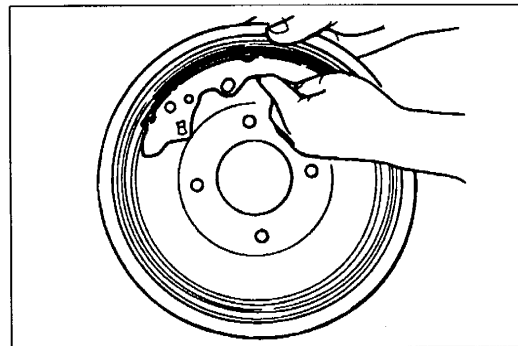

- (2) Scratches, uneven or abnormal wear inside drum

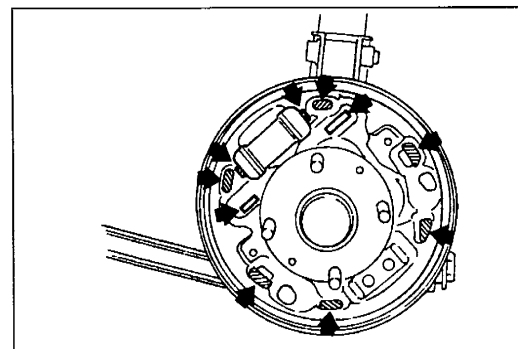

Installation note

Backing plate

Before installing the brake shoes, apply grease to the points as shown.

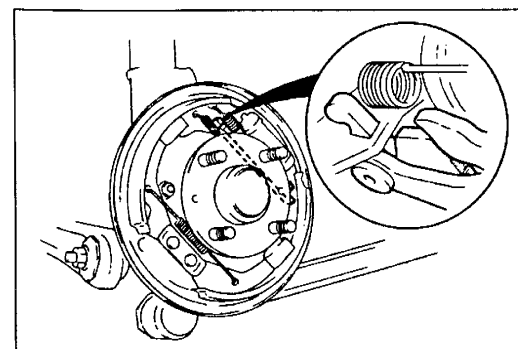

Brake drum

Before installing the brake drum, depress the brake pedal to verify operation of the automatic adjuster.

WHEEL CYLINDER**Disassembly / Inspection / Assembly**

- If any of the metal parts are damaged, replace the wheel cylinder as an assembly.

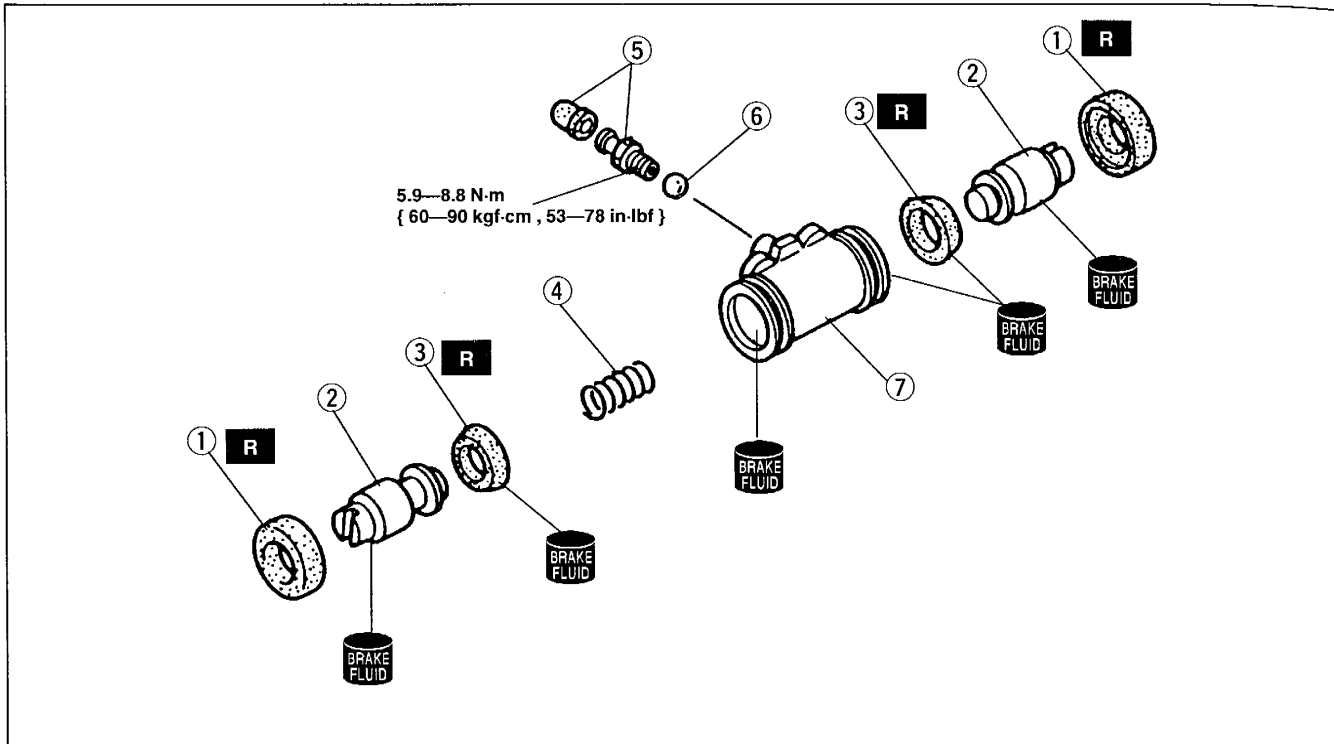

- | | |
|--|--|
| <ol style="list-style-type: none"> 1. Dust boot 2. Piston
Inspect for corrosion and damage 3. Piston cup 4. Spring | <ol style="list-style-type: none"> 5. Bleeder cap and bleeder screw 6. Steel ball 7. Wheel cylinder body
Inspect for corrosion and damage |
|--|--|

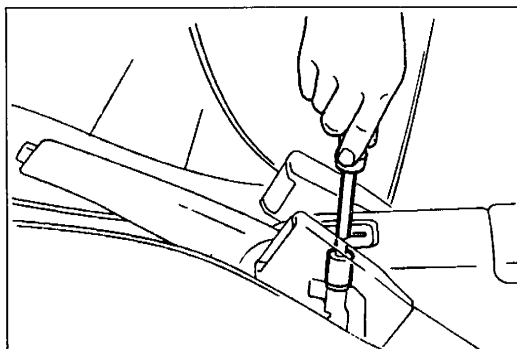
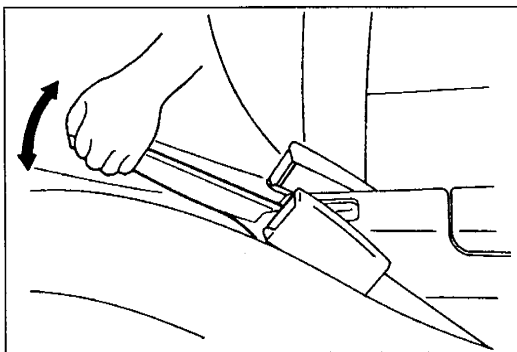
**PARKING BRAKE SYSTEM****PARKING BRAKE (LEVER TYPE)****Inspection (On-vehicle)**

Check that the stroke is within the specification when the parking brake lever is pulled with a force of **98 N { 10 kgf, 22 lbf }**. Adjust if necessary.

Stroke: 5—7 notches

Adjustment

1. Before adjustment, start the engine and depress the brake pedal several times.
2. Stop the engine.
3. Remove the parking brake lever cover.
4. Turn the adjusting nut at the front of the parking cable.
5. After adjustment, check the following points.
 - (1) Turn the ignition switch ON, pull the parking brake lever one notch, and check that the parking brake warning light illuminates.
 - (2) Verify that the rear brakes do not drag.

Removal / Inspection / Installation

- Remove the rear console. (Refer to section S1.)
- After installation, adjust the parking lever stroke. (Refer to page P-28.)

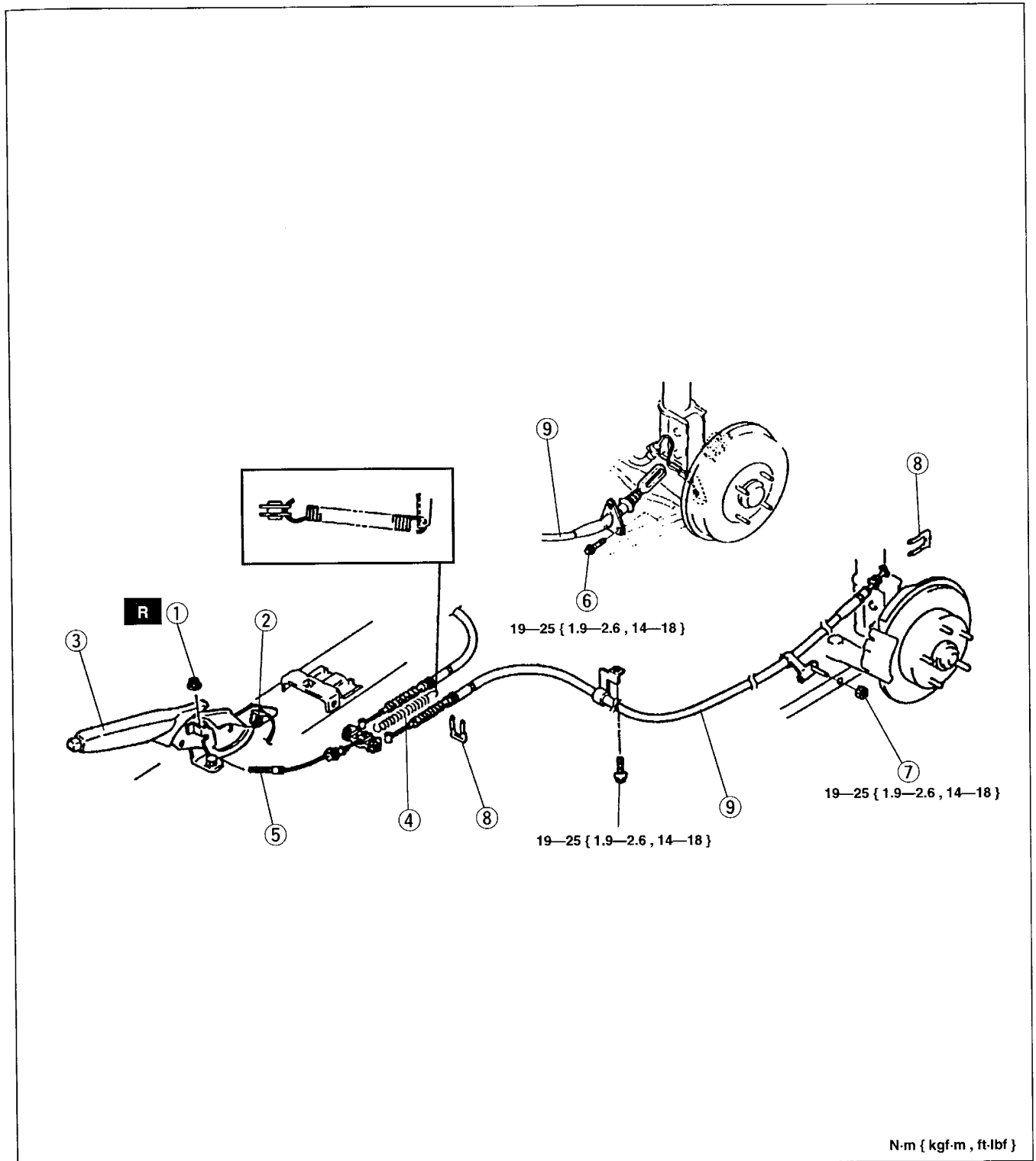



1. Adjusting nut
2. Parking brake switch
3. Parking brake lever assembly
4. Return spring
5. Front parking brake cable
Inspect for wear and damage

6. Bolt
7. Nut
8. Clip
9. Rear parking brake cable
Inspect for wear and damage

ANTILOCK BRAKE SYSTEM (ABS)

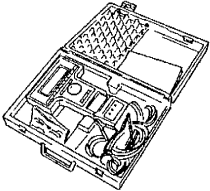
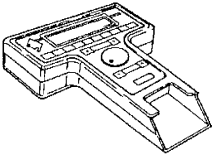
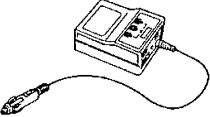
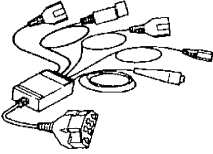
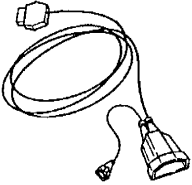
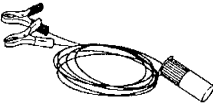
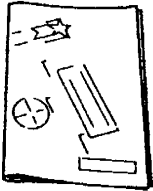
**PREPARATION
SST**

<p>49 0259 770B Wrench, flare nut</p> 	<p>For removal and installation of brake pipe</p>	<p>49 T088 0A0 NGS set</p> 	<p>For diagnosis</p>
<p>49 T088 001 Control Unit (Part of 49 T088 0A0)</p> 	<p>For diagnosis</p>	<p>49 T088 002 Vehicle Interface Module (Part of 49 T088 0A0)</p> 	<p>For diagnosis</p>
<p>49 T088 003 Super MECS Adapter (Part of 49 T088 0A0)</p> 	<p>For diagnosis</p>	<p>49 T088 005 STAR/DCL Adapter (5 pin) (Part of 49 T088 0A0)</p> 	<p>For diagnosis</p>
<p>49 T088 006 Battery Hookup Adapter (Part of 49 T088 0A0)</p> 	<p>For diagnosis</p>	<p>49 T088 008A Instruction Manual</p> 	<p>For diagnosis</p>
<p>49 T088 010B Program Card</p> 	<p>For diagnosis</p>	<p>—</p>	<p>—</p>

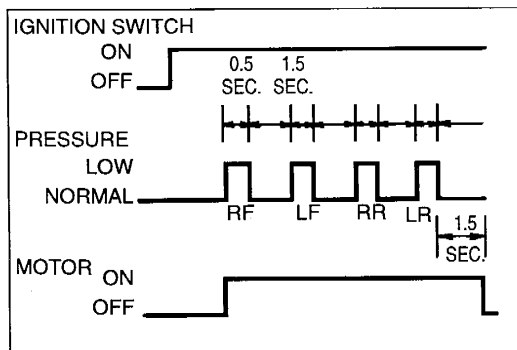
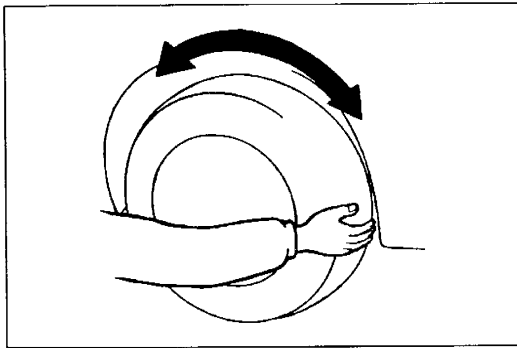
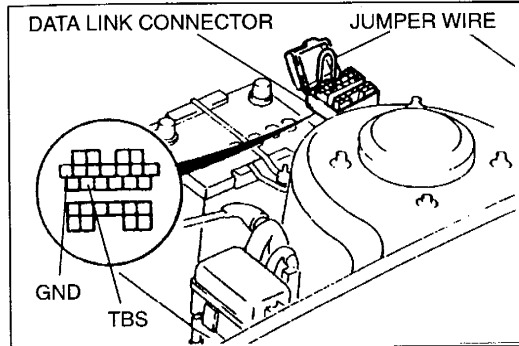
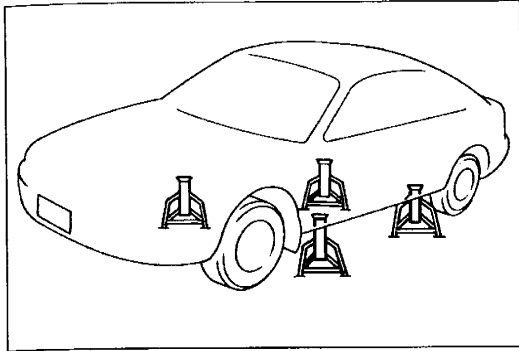

**ABS HYDRAULIC UNIT
Inspection (on-vehicle)
System inspection**

1. Verify that the battery is fully charged.
With the ignition switch ON, verify that the ABS warning light goes out after **2—4 seconds**.
2. If the light stays ON after **2—4 seconds** the control module detects a failure and will not activate the hydraulic unit. Follow the troubleshooting procedures.
3. Turn the ignition switch OFF.
4. On level ground, jack up the vehicle and support it evenly on safety stands. Shift the transaxle to neutral or N range.
5. Release the parking brake.
6. Rotate the wheels by hand, and inspect for brake drag.
7. Using a jumper wire, connect the TBS and GND terminals of the data link connector.
8. Depress the brake pedal, and have an assistant verify that the right front wheel will not turn.
9. With the brake pedal still depressed, turn the ignition switch ON and verify that the brake is released momentarily (approx. **0.5 sec.**) and that the wheel turns when pressure-reduction operates.
10. Check operation of the remaining wheels in order: left front, right rear, left rear.
11. If steps 9 and 10 show correct operation, the following systems are OK.
 - Brake piping to ABS hydraulic unit
 - Braking system, including ABS hydraulic unit
 - Electrical system in ABS hydraulic unit (solenoid, ABS motor, etc.)
 - ABS control module, its output system (solenoid, relay, etc.) and harness.

The following are not checked with the above steps.

 - Input system and harness of ABS control module
 - Intermittent failure
 - Fluid leakage
12. Replace the ABS hydraulic unit if necessary.

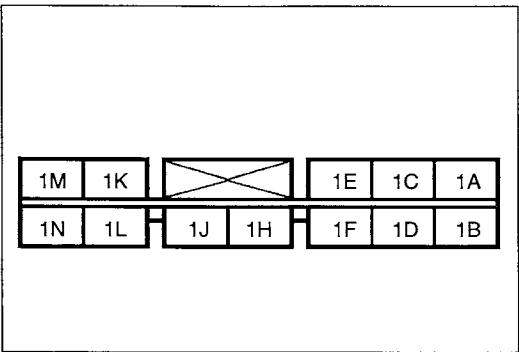

ABS motor (including harness to ABS control module)

1. Turn the ignition switch OFF and disconnect the ABS control module connector.
2. Measure the resistance between terminal 1L of the control module connector and a ground.

Resistance: 1 Ω max.

3. If not as specified, check the wiring harness between the ABS motor and the control module, and check the ABS motor. (Refer to below.)

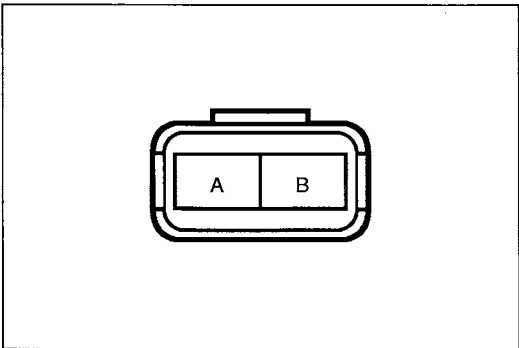

ABS motor

1. Turn the ignition switch OFF.
2. Disconnect the ABS hydraulic unit connector (2 pin).
3. Measure the resistance between the connector terminals.

Resistance: 1 Ω max.

4. Verify that the motor operates when applying 12 V to the connector (2 pin).
5. If not as specified, repair the harness or replace the ABS hydraulic unit if necessary.

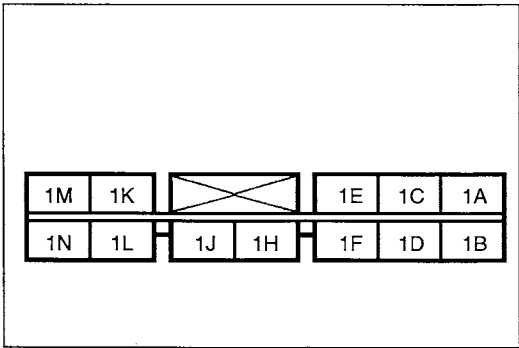

Solenoid valve

(including harness to ABS control module)

1. Turn the ignition switch OFF.
2. Measure the resistance between a ground and the following terminals at the ABS control module connector.

Terminal: 1A: Right rear
 1B: Left front
 1C: Right front
 1D: Left rear

Resistance: Approx. 3 Ω

3. If not as specified, check the wiring harness between the ABS hydraulic unit connector (8 pin) and the ABS control module, and check the solenoid valves. (Refer to below.)

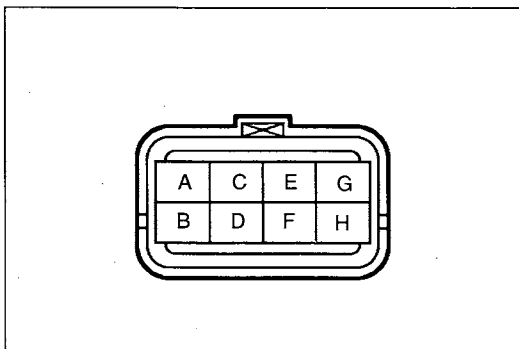

Solenoid valve

1. Disconnect the ABS hydraulic unit connector (8 pin).
2. Measure the resistance between the following terminals.

A—H, B—G, C—F, D—E

Resistance: Approx. 3 Ω

3. If not as specified, repair the hydraulic unit harness or replace the ABS hydraulic unit if necessary.

Removal / Installation

- Remove the battery and the carrier.

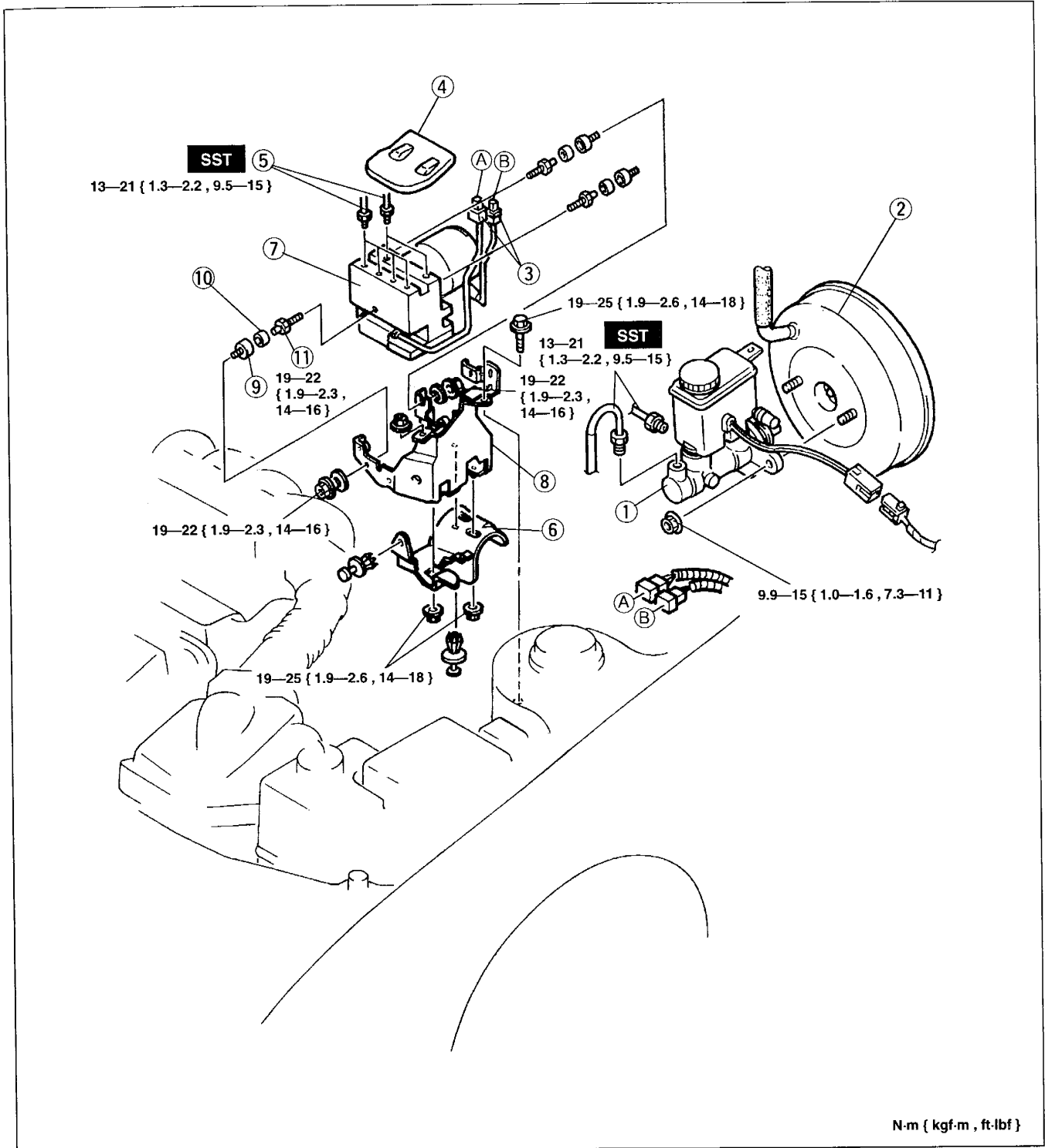

- | | |
|------------------------|-----------------|
| 1. Master cylinder | |
| Removal / Installation | page P- 8 |
| 2. Power brake unit | |
| Removal / Installation | page P-15 |
| 3. Connector | |
| 4. Pipe holder | |
| 5. Brake pipe | |
| Installation Note | page P-34 |

- | | |
|-------------------------------|-----------------|
| 6. Splash shield | |
| 7. ABS hydraulic unit | |
| Installation Note | page P-34 |
| 8. ABS hydraulic unit bracket | |
| 9. Casing | |
| 10. Mount | |
| 11. Hex stud | |

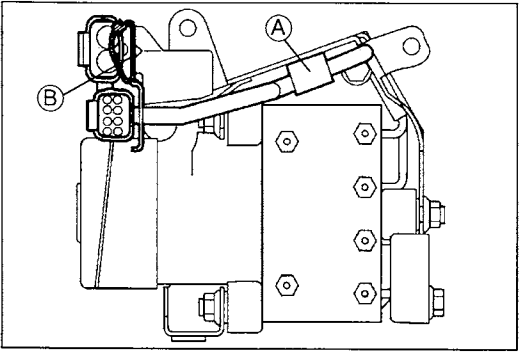

Installation note

ABS hydraulic unit

1. Clamp the harness to point A of the bracket.
2. Install the band around point B of the bracket and the harness, and tighten the band until it contacts the bracket.
3. Leave a few notches of the band and cut off the rest.

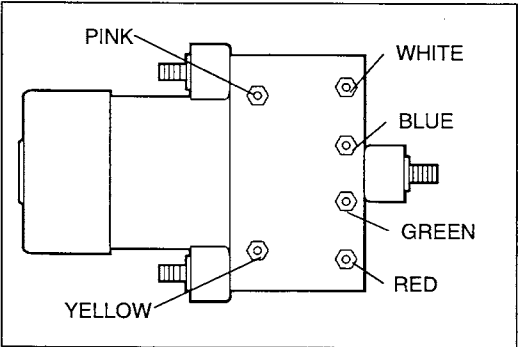

Brake pipe

Align the colors on the brake pipes with the pipe positions of the ABS hydraulic unit as indicated, and install the pipes.

**ABS CONTROL MODULE
Removal / Installation**

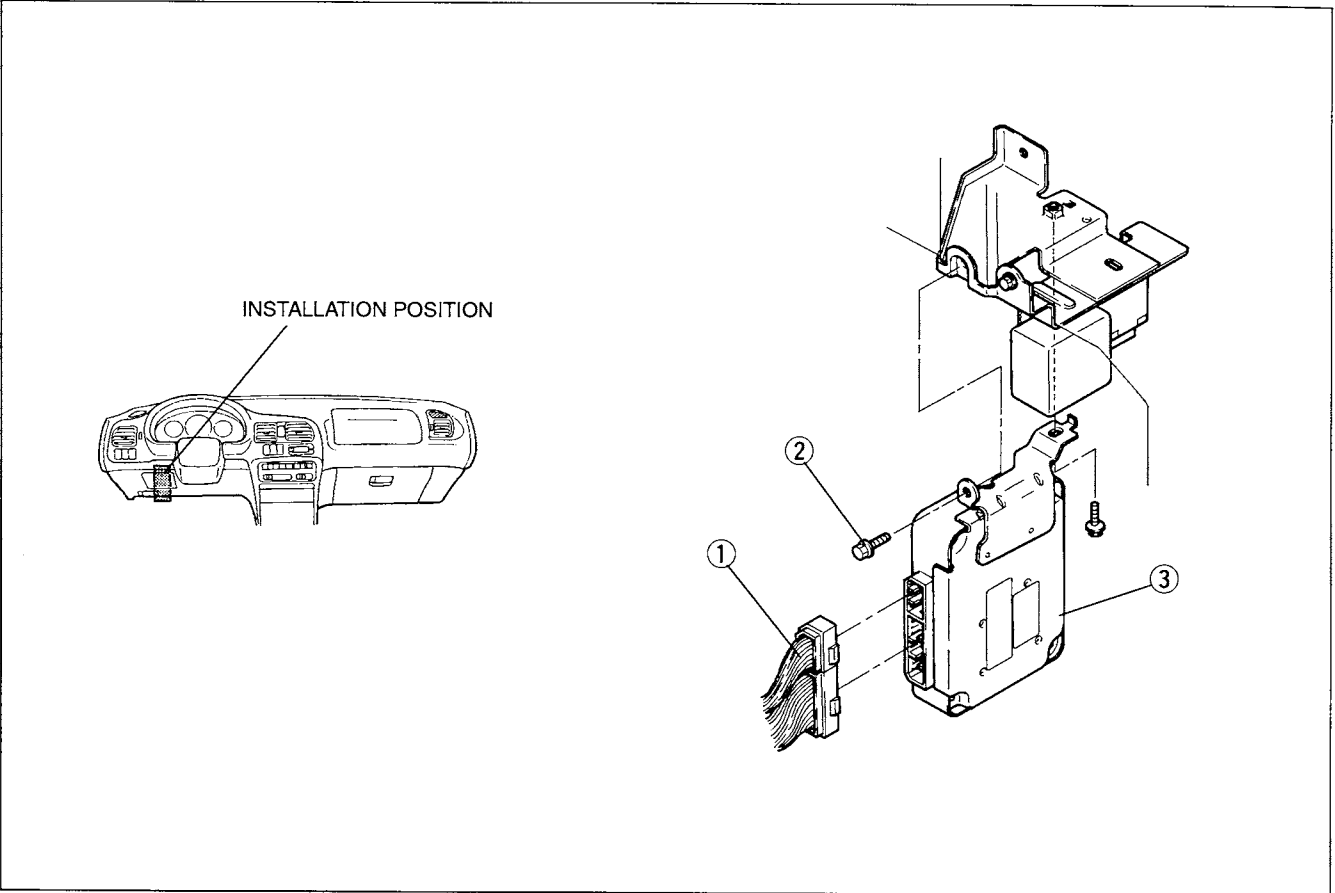

1. Connector
2. Bolt

3. ABS control module
- Inspection page P-35

Inspection

Terminal voltage chart (reference value)

(Ignition switch is ON, and connector is connected unless indicated otherwise)

B+: Battery positive voltage

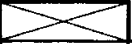
ABS CONTROL MODULE CONNECTOR					
1M	1K		1E	1C	1A
1N	1L	1J	1H	1F	1B
2S	2Q	2O	2M		2G
2T	2R	2P	2N	2L	2J
2H	2F	2D	2B		

Terminal	Signal name	Connected to	Condition	Voltage	Inspection point	
1A	Right rear wheel solenoid	Right rear wheel solenoid	Solenoid ON*	0—2	<ul style="list-style-type: none"> • Harness (HU—ABS CM) • Solenoid valve 	
			Ignition switch ON	B+		
1B	Left front wheel solenoid	Left front wheel solenoid	Solenoid ON*	0—2		
			Ignition switch ON	B+		
1C	Right front wheel solenoid	Right front wheel solenoid	Solenoid ON*	0—2		
			Ignition switch ON	B+		
1D	Left rear wheel solenoid	Left rear wheel solenoid	Solenoid ON*	0—2		
			Ignition switch ON	B+		
1E	Ground	Ground	—	0		<ul style="list-style-type: none"> • Harness condition, open circuit
1F	Ground	Ground	—	0		
1H	Battery	Ignition switch	Ignition switch ON	B+	<ul style="list-style-type: none"> • Harness, fuse (Battery—IG SW—ABS CM) 	
			Ignition switch OFF	0		
1J	—	—	—	—	—	
1K	—	—	—	—	—	
1L	Motor monitor	ABS motor	Motor running	B+	<ul style="list-style-type: none"> • Harness (HU—ABS CM) 	
			Motor stopped	0		
1M	Brake switch	Brake switch	Brake pedal depressed	B+	<ul style="list-style-type: none"> • Harness, fuse (Battery — Brake SW—ABS CM) 	
			Brake pedal released	0		
1N	—	—	—	—	—	

* Solenoid valve is ON only when ABS is functioning. Voltage when solenoid is ON can be measured by following "ABS hydraulic unit system inspection". (Refer to page P-31.)

ANTILOCK BRAKE SYSTEM (ABS)

B+: Battery positive voltage

Terminal	Signal name	Connected to	Condition	Voltage	Inspection point
2A	On-board diagnosis	FBS check terminal	—	10—12	• Harness, fuse (Battery—ABS CM)
2B	On-board diagnosis	TBS check terminal	Normal mode	10—12	
			Diagnostic test mode	0	
2C	—	—	—	—	—
2D	—	—	—	—	—
2E	—	—	—	—	—
2F	—	—	—	—	—
2G	—	—	—	—	—
2H	Motor relay (coil)	Motor relay	Motor relay ON	0—2	• Harness (ABS relay—ABS CM) • Motor relay
			Motor relay OFF	B+	
2J	Fail-safe relay (coil)	Fail-safe relay	Normal	0—2	• Harness (ABS relay—ABS CM) • Fail-safe relay
			If malfunction present	B+	
2L	ABS warning light	ABS warning light	Illuminated	0	• Harness, fuse (Battery—warning light—ABS CM) • ABS warning light
			Not illuminated	B+	
2M*	Right front wheel-speed	Right front wheel-speed sensor	Vehicle stopped	0	• Harness (Wheel-speed sensor—ABS CM) • Wheel-speed sensor
2N*			Wheel turned 1 revolution per second	0.25—3.0 (AC)	
2O*	Left front wheel-speed	Left front wheel-speed sensor	Vehicle stopped	0	
2P*			Wheel turned 1 revolution per second	0.25—3.0 (AC)	
2Q*	Left rear wheel-speed	Left rear wheel-speed sensor	Vehicle stopped	0	
2R*			Wheel turned 1 revolution per second	0.25—3.0 (AC)	
2S*	Right rear wheel-speed	Right rear wheel-speed sensor	Vehicle stopped	0	
2T*			Wheel turned 1 revolution per second	0.25—3.0 (AC)	

* Check following terminals in AC range: 2M—2N (right front), 2O—2P (left front), 2R—2Q (left rear), 2S—2T (right-rear)
In DC range, voltage will be approx. 1.0V (with ignition switch ON)

ABS RELAY

Removal / Inspection / Installation

Note

- The ABS relay contains the fail-safe relay and the motor relay.
- Remove the left side headlight. (Refer to section S1.)

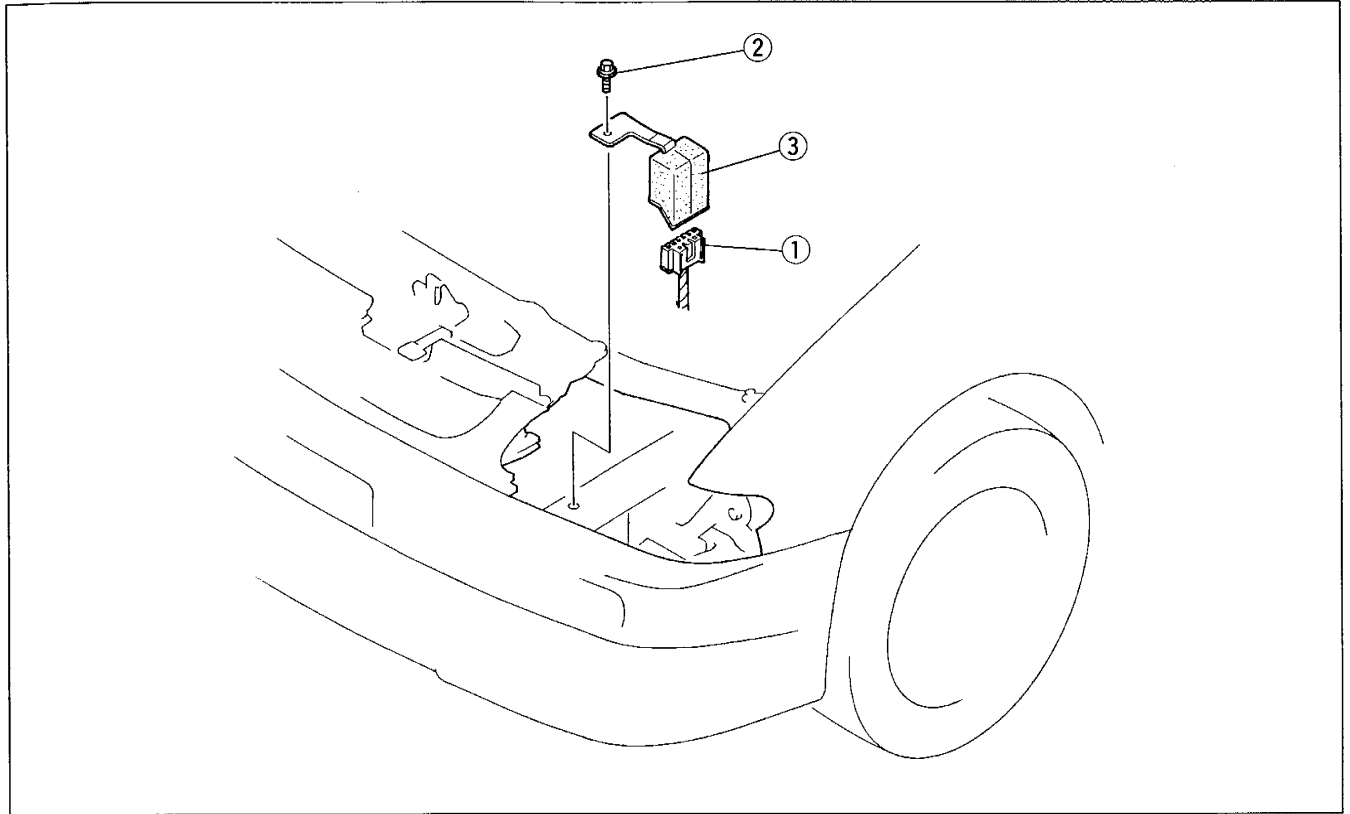

- 1. Connector
- 2. Bolt

- 3. ABS relay
Inspection below

2S	2Q	2O	2M		2G	2E	2C	2A	
2T	2R	2P	2N	2L	2J	2H	2F	2D	2B

Inspection

Fail-safe relay (including harness to ABS CM)

1. Turn the ignition switch OFF and disconnect the ABS control module connector.
2. Turn the ignition switch ON.
3. Connect terminal 2J of the control module connector to a ground.
4. Check the following points.

Condition	Action
Fail-safe relay in ABS relay does not click when 2J terminal grounded	<ul style="list-style-type: none"> • Check fail-safe relay • Check harness between fail-safe relay and ABS control module
Warning light illuminates after grounding 2J terminal	<ul style="list-style-type: none"> • Check fail-safe relay
1D terminal of ABS control module connector does not indicate 12 V	<ul style="list-style-type: none"> • Check fail-safe relay • Check harness between fail-safe relay and ABS hydraulic unit

5. If not as specified, inspect the wiring harness and the fail-safe relay. (Refer to page P-38.)

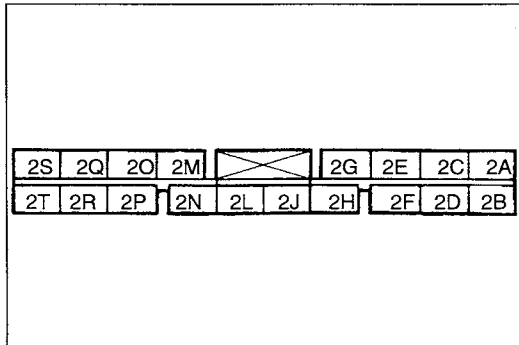
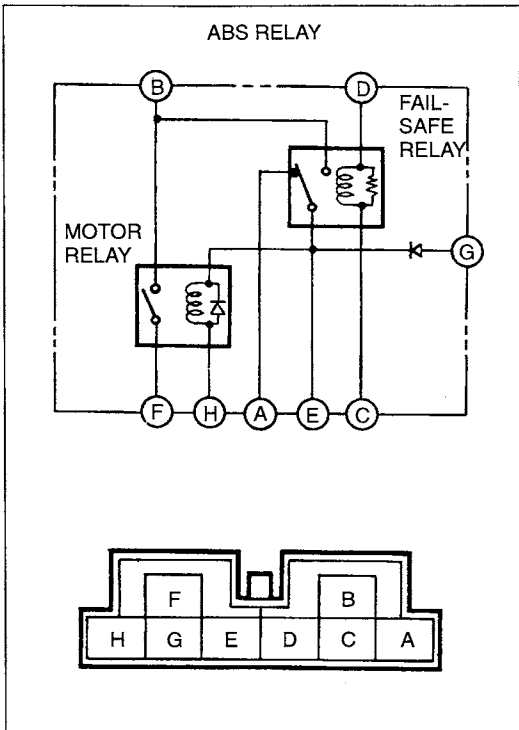

Fail-safe relay

1. Measure resistance between terminals C and D of ABS relay connector.

Resistance: 60—100 Ω

2. Check for continuity between the relay terminals.

○—○: Continuity B+: Battery positive voltage

Step	Terminal	D	C	A	E	B
1				○—○		
2		B+	GND		○—○	

3. If not as specified, replace the ABS relay.

Motor relay (including harness to ABS CM)

1. Inspect the fail-safe relay.
2. Turn the ignition switch OFF and disconnect the ABS control module connector.
3. Turn the ignition switch ON.
4. Connect terminal 2J to a ground.
5. Connect terminal 2H to a ground.
6. Check the following points.
Allowing the motor to operate for more than **two seconds** will damage the motor.

Condition	Action
Motor relay in ABS relay does not click when terminals grounded	<ul style="list-style-type: none"> • Check harness between motor relay and ABS control module • Check motor relay
Motor does not operate	<ul style="list-style-type: none"> • Check motor relay • Check harness between motor relay and motor • Check fuse

7. If not as specified, inspect the wiring harness and the motor relay. (Refer to page P-39.)

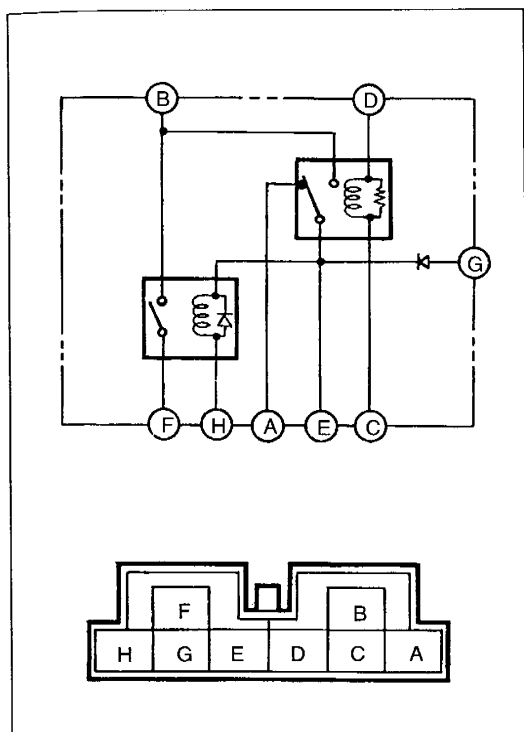

Motor relay

1. Measure the resistance between terminals E and H, or between A and H of the ABS relay connector.

Resistance: 50—90 Ω

2. Check for continuity between the relay terminals.

○—○: Continuity B+: Battery positive voltage

Step	Terminal	G	H	B	F
1		○ → ○			
2		B+	GND	○ — ○	○ — ○

3. If not as specified, replace the ABS relay.

ABS WHEEL-SPEED SENSOR (FRONT)
Removal / Installation

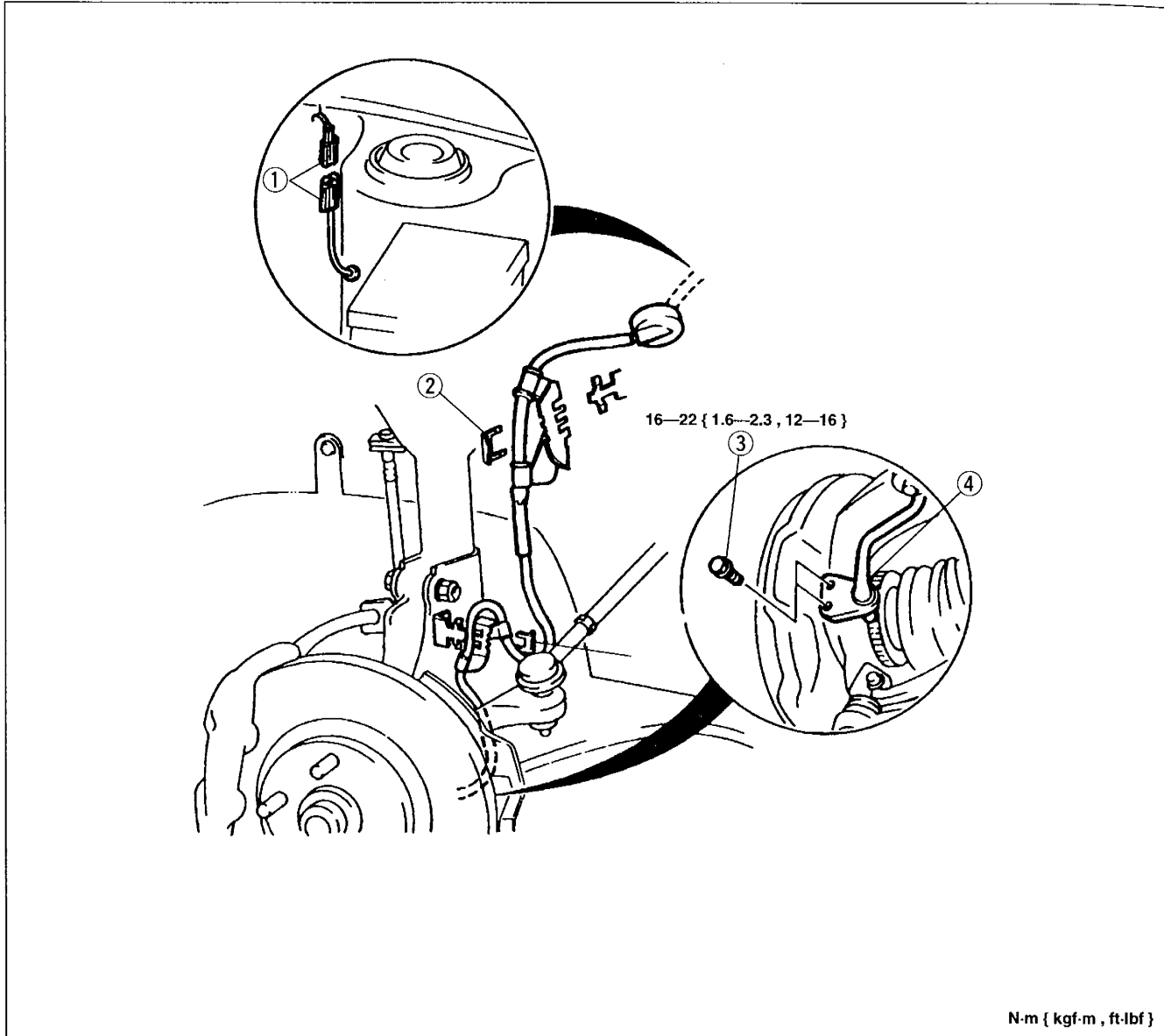

- 1. Connector
- 2. Clip
- 3. Bolt

- 4. ABS wheel-speed sensor
Inspection (on-vehicle) below

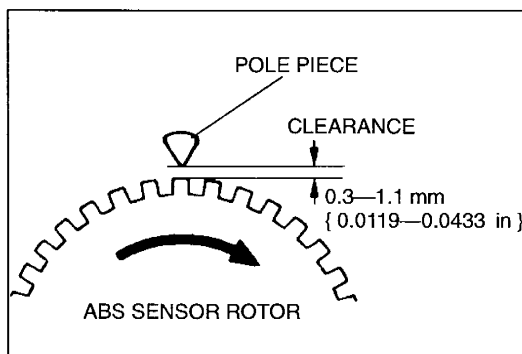

Inspection (On-vehicle)

- 1. Remove the wheel and tire, and inspect the sensor for looseness and damage. Replace the sensor if necessary.
- 2. Check the clearance between the wheel-speed sensor and the sensor rotor.

Clearance: 0.3—1.1 mm { 0.0119—0.0433 in }

- 3. If not as specified, replace the ABS wheel-speed sensor or sensor rotor as necessary.

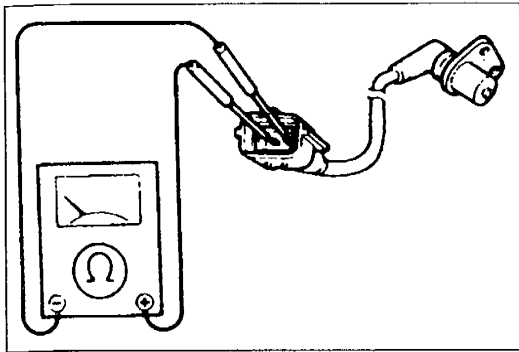

Resistance of ABS wheel-speed sensor

1. Disconnect the ABS wheel-speed sensor connector.
2. Check the resistance at the ABS wheel-speed sensor.

Resistance: 1.3—2.0 kΩ

Voltage of ABS wheel-speed sensor

1. On level ground, jack up the vehicle and support it evenly on safety stands.
2. Disconnect the ABS wheel-speed sensor connector.
3. Check each wheel by rotating it at one revolution per second.

Voltage: 0.25—3.0 V (AC)

4. If not as specified, replace the ABS wheel-speed sensor or sensor rotor as necessary.

**ABS WHEEL-SPEED SENSOR (REAR)
Removal / Installation**

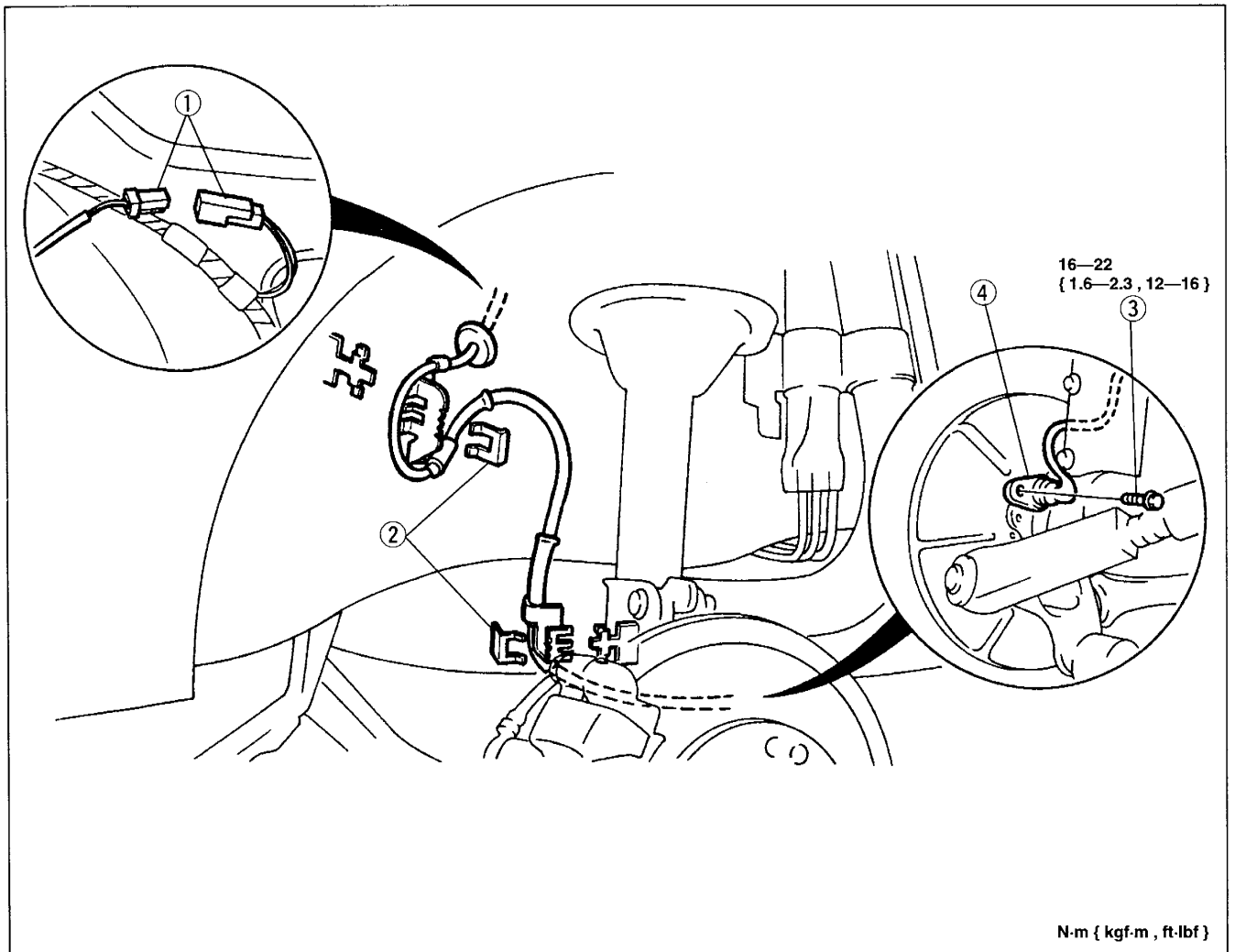

1. Connector
2. Clip
3. Bolt

4. ABS wheel-speed sensor
Inspection (on-vehicle) page P-40

ON-BOARD DIAGNOSTIC FUNCTION

On-Board Diagnostic System

Inspection by diagnostic test mode

Outline

- The ABS control module contains an on-board diagnostic and memory functions to detect and indicate present and past failures.
Read and note the diagnostic indications by using the **SST**, and take action according to the Diagnostic Trouble Code Table. (Refer to page P-44.)
- The ABS CM has a nonvolatile memory. Diagnostic trouble codes are not erased if the battery is disconnected. The memory should be cleared when servicing is finished. (Refer to page P-43.)

Inspection using NGS

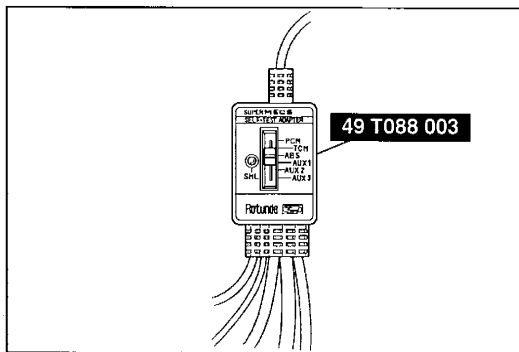
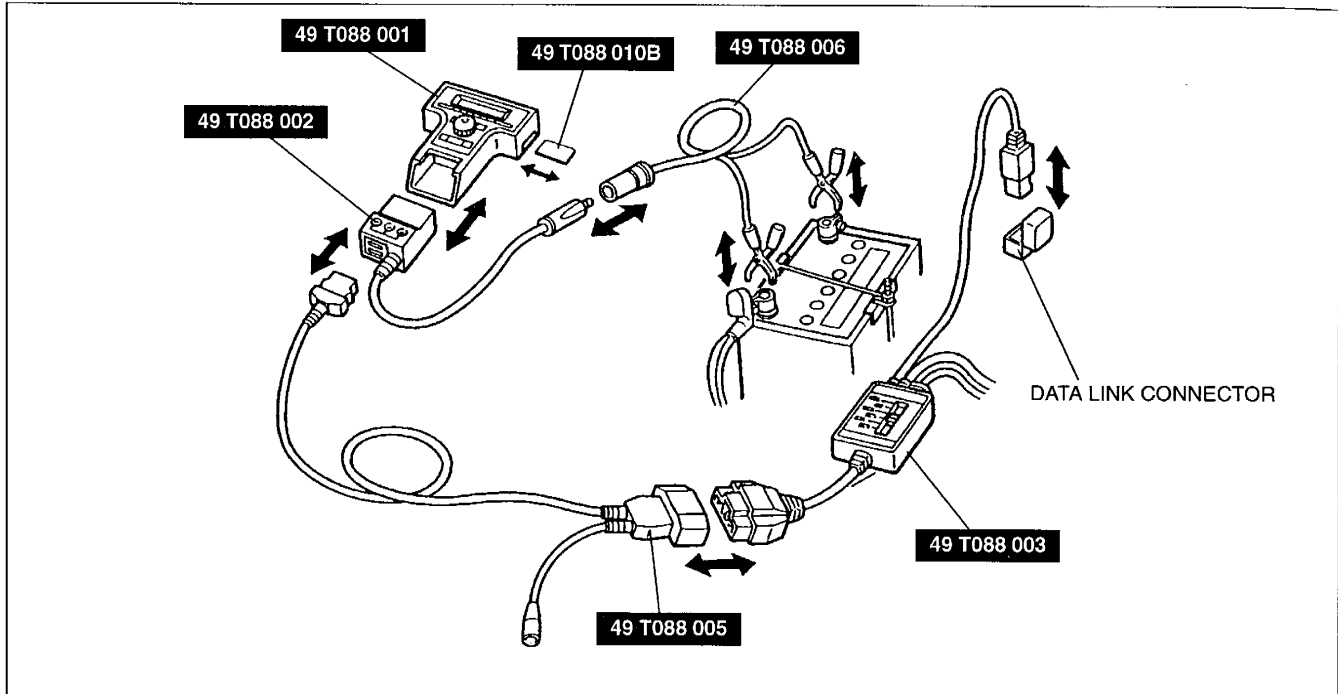

1. Connect the **SST** (NGS) to the data link connector and battery.
2. Set the **SST** (Super MECS Adapter) to ABS.

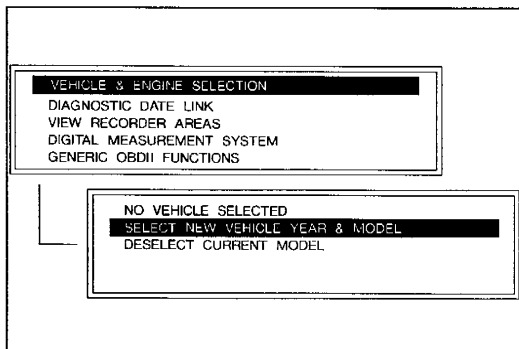

3. Select "VEHICLE & ENGINE SELECTION" on the **SST** (Control Unit) display, and then select the vehicle model, engine type, and model year.

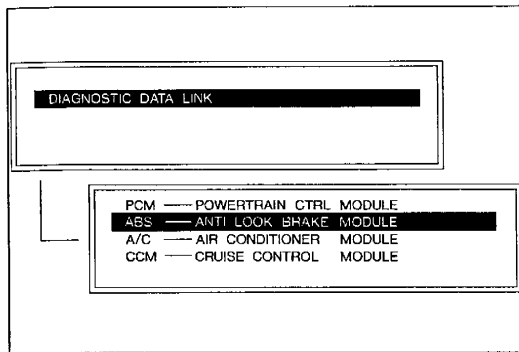

4. Select "DIAGNOSTIC DATA LINK" on the **SST**, (Control Unit) display.
5. Select "ANTI LOCK BRAKE MODULE" on the **SST** (Control Unit) display.

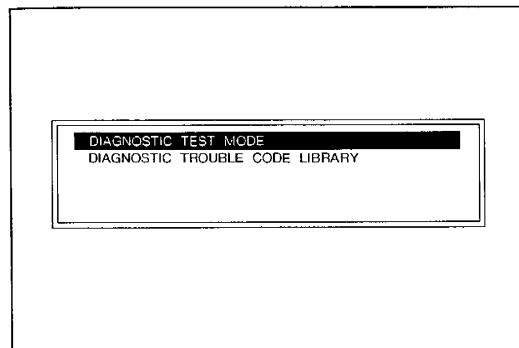

6. Select "DIAGNOSTIC TEST MODE" on the **SST** (Control Unit) display.
7. (1) If a trouble code is displayed, refer to the Diagnostic trouble code table (Refer to page P-47.) and inspect the appropriate system area.
- (2) If "No codes received" is displayed, the system areas shown in the Diagnostic trouble code table are okay. Inspect another system area.

Memory cancel

The ABS control module has a nonvolatile memory. Diagnostic trouble codes are not erased if the battery is disconnected. The memory should be cleared when servicing is finished.

Diagnostic trouble codes memorized in the ABS control module are canceled by performing the following steps.

1. Connect the TBS terminal to GND at the data link connector.
2. Turn the ignition switch ON.
3. Output all memorized codes.
4. After verifying that the first code is repeated, depress the brake pedal 10 times at intervals of less than **one second (1 sec.)**.

Diagnostic trouble codes cannot be canceled if the following occur.

- If intervals of depressing the brake pedal exceed **one second (1 sec.)**.
- Brake switch has failed.

While performing the memory cancel operation, the ABS warning light is not illuminated.

When the memory cancel operation is completed, the ABS warning light comes on for **2—3 seconds**, then goes off.

After the memory is canceled, the ABS control module performs on-board diagnosis.

Diagnostic trouble code table

DTC	Display on the NGS	Possible cause	Page
11	WSS, SR (RH-FRONT) — OPEN OR SHORT, DEFECT	Right front wheel-speed sensor Right front sensor rotor	P-45
12	WSS, SR (LH-FRONT) — OPEN OR SHORT, DEFECT	Left front wheel-speed sensor Left front sensor rotor	
13	WSS, SR (RH-REAR) — OPEN OR SHORT, DEFECT	Right rear wheel-speed sensor Right rear sensor rotor	
14	WSS, SR (LH-REAR) — OPEN OR SHORT, DEFECT	Left rear wheel-speed sensor Left rear sensor rotor	
15*	WSS — OPEN OR SHORT	Wheel-speed sensor	P-45
22	SOLV (RH-FRONT) — OPEN OR SHORT	Right front solenoid valve	P-46
24	SOLV (LH-FRONT) — OPEN OR SHORT	Left front solenoid valve	
26	SOLV (RH-REAR) — OPEN OR SHORT	Right rear solenoid valve	
28	SOLV (LH-REAR) — OPEN OR SHORT	Left rear solenoid valve	
51	FAIL SAFE RELAY — OPEN OR SHORT, DEFECT	Fail-safe relay	P-46
53	MOTOR, MOTOR RELAY — OPEN OR SHORT, DEFECT	ABS motor Motor relay	P-47
61	ABS CONTROL UNIT — DEFECT	ABS control module	P-47

* If the ignition switch is turned OFF and the ON again, and the vehicle is then accelerated to higher than 10 km/h { 6.2 MPH }, diagnostic trouble code 15 will be replaced by a code from 11 through 14.

Diagnostic chart

Diagnostic trouble code No.11-14		ABS wheel-speed sensor (11: Right front 12: Left front 13: Right rear 14: Left rear)	
Possible cause		<ul style="list-style-type: none"> • Malfunction of ABS wheel-speed sensor, sensor rotor, or ABS hydraulic unit • Malfunction of related wiring harness 	
STEP	INSPECTION	ACTION	
1	Is ABS CM connector connected properly?	Yes	Go to next step
		No	Correct as necessary
2	Is wiring harness between ABS CM and wheel-speed sensor OK?	Yes	Go to next step
		No	Correct as necessary
3	Is ABS wheel-speed sensor OK? ☞ page P-40	Yes	Go to next step
		No	Replace ABS wheel-speed sensor ☞ page P-40, 41
4	Are there missing or damaged teeth on sensor rotor?	Yes	Replace sensor rotor ☞ section M
		No	Go to next step
5	Is brake switch OK? ☞ page P-7	Yes	Go to next step
		No	Replace brake switch ☞ page P-7
6	Is ABS hydraulic unit OK? ☞ page P-31	Yes	Go to next step
		No	Replace ABS hydraulic unit ☞ page P-33
7	Erase diagnostic trouble code, and recheck for diagnostic trouble codes after driving over 10 km/h { 6.2 MPH } Is diagnostic trouble code 11-14 obtained?	Yes	Replace ABS CM ☞ page P-34
		No	There was a temporarily poor contact in wiring harness or connector

Diagnostic trouble code No.15		ABS wheel-speed sensor	
Possible cause		<ul style="list-style-type: none"> • Malfunction of ABS wheel-speed sensor • Malfunction of related wiring harness 	
STEP	INSPECTION	ACTION	
1	Erase diagnostic trouble code, and recheck for diagnostic trouble codes after driving over 10 km/h { 6.2 MPH } Is diagnostic trouble code obtained?	Yes	Code of 11-14 is obtained: Go to above chart Code 15 is obtained: Replace ABS CM ☞ page P-34
		No	There was a temporarily poor contact in wiring harness or connector

ANTILOCK BRAKE SYSTEM (ABS)

Diagnostic trouble code No.22, 24, 26, 28		Solenoid valve (22: Right-front 24: Left front 26: Right rear 28: Left rear)	
Possible cause		<ul style="list-style-type: none"> • Malfunction of solenoid valve • Malfunction of related wiring harness 	
STEP	INSPECTION	ACTION	
1	Is ABS CM connector connected properly?	Yes	Go to next step
		No	Correct as necessary
2	Inspect solenoid valve including harness Is it OK? ☞ page P-32	Yes	Go to step 4
		No	Go to next step
3	Is solenoid valve OK? ☞ page P-32	Yes	Go to next step
		No	Replace ABS hydraulic unit ☞ page P-33
4	Erase diagnostic trouble code, and re-check for diagnostic trouble codes Is diagnostic trouble code 22—28 obtained?	Yes	Replace ABS CM ☞ page P-34
		No	There was a temporarily poor contact in wiring harness or connector

Diagnostic trouble code No.51		Fail-safe relay	
Possible cause		<ul style="list-style-type: none"> • Malfunction of fail-safe relay • Malfunction of related wiring harness 	
STEP	INSPECTION	ACTION	
1	Is engine fuse (10 A) OK?	Yes	Go to next step
		No	Replace fuse
2	Inspect fail-safe relay including harness Is it OK? ☞ page P-38	Yes	Go to step 4
		No	Go to next step
3	Is fail-safe relay OK? ☞ page P-38	Yes	Go to next step
		No	Replace ABS relay ☞ page P-37
4	Erase diagnostic trouble code, and re-check for diagnostic trouble codes Is diagnostic trouble code 51 obtained?	Yes	Replace ABS CM ☞ page P-34
		No	There was a temporarily poor contact in wiring harness or connector

Diagnostic trouble code No.53		ABS motor, motor relay		
Possible cause		<ul style="list-style-type: none"> • Malfunction of motor or motor relay • Malfunction of related wiring harness 		
STEP	INSPECTION		ACTION	
1	With ignition switch OFF, is motor operating?	Yes	Replace ABS relay ☞ page P-37	
		No	Go to next step	
2	Is ABS fuse (40 A) OK?	Yes	Go to next step	
		No	Replace fuse	
3	Inspect motor relay including harness Is it OK? ☞ page P-38	Yes	Go to step 7	
		No	Go to next step	
4	Is motor relay OK? ☞ page P-39	Yes	Go to next step	
		No	Replace ABS relay ☞ page P-37	
5	Inspect ABS motor, including harness Is it OK? ☞ page P-32	Yes	Go to step 7	
		No	Go to next step	
6	Is ABS motor OK? ☞ page P-32	Yes	Correct harness as necessary	
		No	Replace ABS hydraulic unit ☞ page P-33	
7	Erase diagnostic trouble code, and re-check for diagnostic trouble code Is diagnostic trouble code 53 obtained?	Yes	Replace ABS CM ☞ page P-34	
		No	There was a temporarily poor contact in wiring harness or connector	

Diagnostic trouble code No.61		ABS control module		
Possible cause		<ul style="list-style-type: none"> • Malfunction of control module 		
STEP	INSPECTION		ACTION	
1	Erase diagnostic trouble code, and re-check for diagnostic trouble code Is diagnostic trouble code 61 obtained?	Yes	Replace ABS CM ☞ page P-34	
		No	There was a temporarily poor contact in wiring harness or connector	

TROUBLESHOOTING

Troubleshooting Notes

The ABS is composed of electrical components, mechanical components (ABS hydraulic unit), and the components of the standard brake system.

Fundamentally, malfunction of the ABS electrical or mechanical components is judged by the on-board diagnostic function within the ABS control module. Malfunctions are indicated by the warning light in the instrument panel. The technician can locate a malfunction by switching the system to the diagnostic test mode.

The on-board diagnostic system must be used when diagnosing malfunctions of the ABS.

Precaution

Conditions that are not malfunctions

1. Vibration can sometimes be felt in the steering wheel, body, and/or brake pedal when the ABS is functioning; such vibration is simply an indication that the system is functioning.
2. The ABS warning light may illuminate under any of the following conditions.
 - When the vehicle is travelling on snow or ice with the parking brake activated or a brake dragging at one wheel.
 - When different size tires are used.
 - When tires of different gripping performance are used.
 - When (While the vehicle is jacked up or stuck) the front wheels only are spun for **20 seconds** or more.
 - When there is insufficient battery voltage.
3. Under the above conditions, the warning light will not illuminate a second time when the ignition is switched OFF then back ON, and there will also be no diagnostic trouble code entry made to the control module memory.

Diagnostic Chart

Cause		Input				Output				
		ABS wheel-speed sensor	Brake switch	ABS relay		ABS hydraulic unit		ABS warning light	Data link connector	ABS control module
				Fail-safe relay	Motor relay	Solenoid valve	ABS motor			
Symptom										
1	ABS warning light not illuminated when ignition switch turned ON							○		
2	ABS warning light remains ON	○	○	○	○	○	○	○		○
3	ABS warning light flashes								○	

**Using This Section
Work flow**

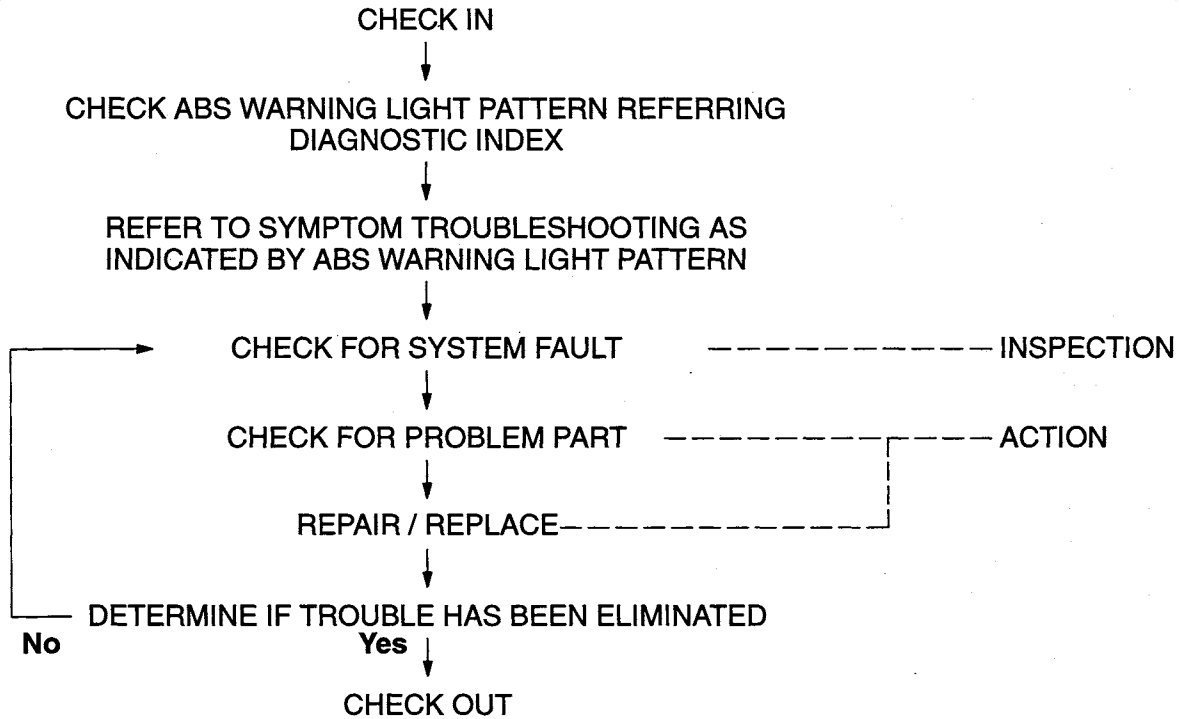

Diagnostic index

TROUBLESHOOTING ITEMS		DESCRIPTION	PAGE
No.	TROUBLE		
1	ABS warning light not illuminated when ignition switch turned ON	—	below
2	ABS warning light remains ON	Warning light remains ON and ABS does not operate	P-52

No.:

Each troubleshooting item is assigned a number.

TROUBLESHOOTING ITEMS:

There are 3 troubleshooting items. Choose the item indicated by the ABS warning light.

DESCRIPTION:

Describes details of the symptom.

PAGE:

Shows the reference page.

Symptom troubleshooting

1	ABS WARNING LIGHT NOT ILLUMINATED WHEN IGNITION SWITCH TURNED ON		
DESCRIPTION			
<p>[TROUBLESHOOTING HINTS]</p> <ul style="list-style-type: none"> • If other warning indicators do not illuminate, METER 15 A fuse may be burnt. • Failed warning light or open in related wiring harness. 			
STEP	INSPECTION		ACTION
1	Is METER 15 A fuse OK?	Yes	Go to next step
		No	Replace METER 15 A fuse
2	Is harness of ABS warning light normal?	Yes	Inspect ABS warning light bulb and replace if necessary
		No	<ul style="list-style-type: none"> • Inspect harness between ABS CM and ABS relay • Inspect harness between instrument panel and ABS CM • Inspect harness between instru

DESCRIPTION:

Further describes the system. Confirm that the chart addresses the actual symptom before beginning troubleshooting.

TROUBLESHOOTING HINTS:

This describes the possible point of malfunction.

STEP:

This shows the order of troubleshooting. Proceed with troubleshooting as indicated.

INSPECTION:

This describes an inspection to quickly determine the malfunction of parts. If a detailed procedure is necessary to perform the INSPECTION, refer to the page specified by the "IS" mark.

ACTION:

This recommends the appropriate action to take as a result (Yes/No) of the INSPECTION. How to perform the actions is described on the reference page specified by the "IS" mark.

Diagnostic Index

TROUBLESHOOTING ITEMS		DESCRIPTION	PAGE
No.	TROUBLE		
1	ABS warning light not illuminated when ignition switch turned ON	—	below
2	ABS warning light remains ON	Warning light remains ON and ABS does not operate	P-52
3	ABS warning light flashes	—	P-52

Symptom Troubleshooting

1	ABS WARNING LIGHT NOT ILLUMINATED WHEN IGNITION SWITCH TURNED ON		
DESCRIPTION		—	
[TROUBLESHOOTING HINTS]			
<ul style="list-style-type: none"> • If other warning indicators do not illuminate, METER 15 A fuse may be burnt. • Failed warning light or open in related wiring harness. 			
STEP	INSPECTION		ACTION
1	Is METER 15 A fuse OK?	Yes	Go to next step
		No	Replace METER 15 A fuse
2	Is harness of ABS warning light normal?	Yes	Inspect ABS warning light bulb and replace if necessary
		No	<ul style="list-style-type: none"> • Inspect harness between ABS CM and ABS relay • Inspect harness between instrument panel and ABS CM • Inspect harness between instrument panel and ABS relay • Inspect ABS warning light bulb Correct as necessary

ANTILOCK BRAKE SYSTEM (ABS)

2		ABS WARNING LIGHT REMAINS ON	
DESCRIPTION		ABS warning light remains ON and ABS does not operate	
[TROUBLESHOOTING HINTS]			
<ul style="list-style-type: none"> • If only ABS warning light illuminates, activate diagnostic test mode and check for diagnostic trouble code • Malfunction of battery • Malfunction of ABS warning light harness (fail-safe relay) • Malfunction of ABS control module 			
STEP	INSPECTION	ACTION	
1	Activate diagnostic test mode and check for diagnostic trouble codes Are there any? ↳ page P-42	Yes	Read diagnostic trouble code and follow diagnosis chart ↳ page P-44
		No	Go to next step
2	Is ABS CM connector connected?	Yes	Go to next step
		No	Connect connector
3	Is battery as specified?	Yes	Go to next step
		No	Charge or replace if necessary
4	Is ABS warning light harness normal?	Yes	Go to next step
		No	<ul style="list-style-type: none"> • Inspect harness between ABS CM and ABS relay • Inspect harness between instrument panel and ABS CM • Inspect harness between instrument panel and ABS relay Correct as necessary
5	Connect terminal 2J of ABS CM connector to a ground and check the following points (IG ON) <ul style="list-style-type: none"> • Operation sound of relay is heard • ABS warning light is not illuminated • 1D terminal of ABS CM connector indicates battery voltage 	Yes	Go to next step
		No	<ul style="list-style-type: none"> • Inspect ABS relay (fail-safe relay) ↳ page P-38 • Inspect harness between ABS relay (fail-safe relay) and ABS CM, battery • Inspect harness between ABS relay (fail-safe relay) and ABS hydraulic unit Correct as necessary
6	Is voltage at terminals 1E, 1F and 1H of ABS CM connector and terminal 2B and 2L of ABS CM connector as specified? ↳ page P-35	Yes	Replace ABS CM
		No	<ul style="list-style-type: none"> • Inspect harness between ABS CM and ground • Inspect harness between ignition switch and ABS CM • Inspect harness between data link connector and ABS CM • Inspect harness between ABS warning light and ABS CM Correct as necessary

3		ABS WARNING LIGHT FLASHES	
DESCRIPTION		—	
[TROUBLESHOOTING HINTS]			
<ul style="list-style-type: none"> • Data link connector terminal TBS grounded 			
STEP	INSPECTION	ACTION	
1	Verify that there is no continuity between terminal TBS and GND at data link connector	Yes	Inspect ABS CM
		No	Repair short between TBS and GND

WHEELS AND TIRES

OUTLINE Q-2
SPECIFICATIONS Q-2

OUTLINE

SPECIFICATIONS

Standard tire

Item		Specification	
Wheel	Size	14×5 1/2JJ	13×5J
	Offset	mm { in }	45 { 1.77 }
	Pitch circle diameter	mm { in }	100 { 3.94 }
	Material	Steel or aluminum alloy	Steel
Tire	Size (air pressure kPa { kgf/cm ² , psi })	P185/65R14 85S (220 { 2.2, 32 })	P175/70R13 82S (220 { 2.2, 32 })
	Remaining tread	mm { in }	1.6 { 0.063 }
Wheel and tire*	Wheel and tire runout	Radial direction mm { in }	Max. 1.5 { 0.06 }
		Lateral direction mm { in }	Max. 2.5 { 0.10 } Steel, Max. 2.0 { 0.08 } Aluminum
	Wheel imbalance	g { oz }	Max. 10 { 0.35 } 13-inch wheel, Max. 11 { 0.39 } 14-inch wheel

Temporary spare tire

Item		Specification	
Wheel	Size	14×4T	
	Offset	mm { in }	45 { 1.77 }
	Pitch circle diameter	mm { in }	100 { 3.94 }
	Material	Steel	
Tire	Size	T125/70 D14 T115/70 D14	
	Air pressure	kPa { kgf/cm ² , psi }	415 { 4.2, 60 }
Wheel and tire	Wheel and tire runout	Radial direction mm { in }	Max. 2.5 { 0.10 }
		Lateral direction mm { in }	Max. 2.0 { 0.08 }

*Note

- One balance weight: max. 60 g { 2.1 oz }.
- If the total weight exceeds 100 g { 3.5 oz } on one side, rebalance after moving the tire around on the rim.
- Do not use more than two balance weights on the inner or outer side of the wheel.

Before beginning any service procedure, refer to section T1 of this manual for air bag system service warnings.

SUSPENSION

OUTLINE	R- 2
SPECIFICATIONS	R- 2
GENERAL PROCEDURES	R- 3
WHEEL ALIGNMENT	R- 3
PREINSPECTION	R- 3
FRONT WHEEL ALIGNMENT	R- 4
REAR WHEEL ALIGNMENT	R- 5
FRONT SUSPENSION (STRUT)	R- 7
PREPARATION	R- 7
FRONT SHOCK ABSORBER AND SPRING	R- 9
FRONT LOWER ARM	R-16
FRONT STABILIZER	R-19
FRONT CROSSMEMBER	R-21
REAR SUSPENSION (STRUT)	R-22
PREPARATION	R-22
REAR SHOCK ABSORBER AND SPRING	R-23
LATERAL LINK AND TRAILING LINK	R-30
REAR STABILIZER	R-32
REAR CROSSMEMBER	R-34

OUTLINE

SPECIFICATIONS

Item		Type	BP	Z5
Suspension type			Strut	
Shock absorber type			Cylindrical, double-acting (oil-filled)	
Coil spring	Type	Front	Straight wound	
		Rear	Straight wound	
Stabilizer	Type		Torsion bar	
	Diameter	Front	24.0 { 0.94 }	
		Rear	16.0 { 0.63 }	—
Wheel alignment (Unladen)*1				
Front	Maximum steering angle degree	Inner	40° ± 3°	
		Outer	33° ± 3°	
	Total toe-in	mm { in }	2 ± 4 { 0.08 ± 0.16 }	
		degree	0°12' ± 0°24'	
	Camber angle*2		-0°44' ± 1°	
	Caster angle*2		1°55' ± 1°	
Steering axis inclination		degree	13°22'	
Rear	Total toe-in	mm { in }	2 ± 4 { 0.08 ± 0.16 }	
		degree	0°12' ± 0°24'	
	Camber angle*2		-0°49' ± 1°	
	Thrust angle		0° ± 48'	

*1 Fuel tank full; radiator coolant and engine oil at specified level; spare tire, jack, and tools in designated position. Adjust to the median when carrying out wheel alignment.

*2 Difference between left and right must not exceed 1.5°.

GENERAL PROCEDURES

Removal / Installation

- The numbers in the structural view indicate the removal order. For installation, follow the reverse order except for the front and rear shock absorber and spring. (Refer to page R-12, R-26.)

Wheel and tires

- The removal and installation procedures for the wheels and tires are not mentioned in this section. If you must remove the wheels, retighten it to **89—127 N·m { 9.0—13.0 kgf·m , 66—94 ft·lbf }**

Suspension links

- Tighten any part of the suspension that uses rubber bushings only after the vehicle has been lowered and unloaded. If a suspension part(s) has been removed anytime during the procedure, inspect the wheel alignment.

Brake pipe flare nuts

- Tighten the brake pipe flare nut by using the **SST** (49 0259 770B). Be sure to modify the brake pipe flare nut tightening torque to allow for use of a torque wrench-SST combination. (Refer to section G1 "Torque Formulas".)

Power steering components

- If a power steering fluid line(s) has been disconnected anytime during the procedure add ATF (Dexron® II or M-III), bleed the fluid line(s), and inspect for leakage after the procedure has been completed.

R

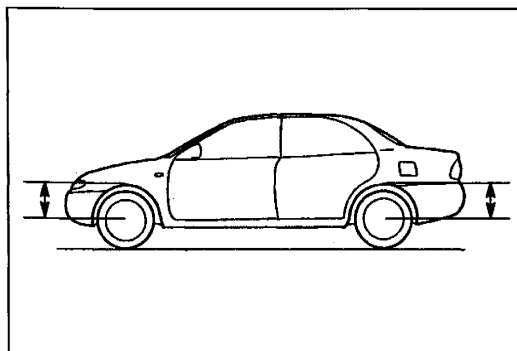
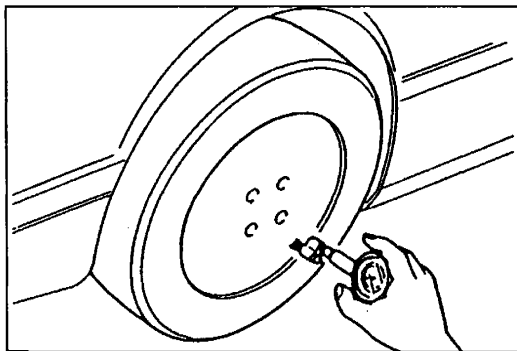

WHEEL ALIGNMENT

PREINSPECTION

1. Check the inflation of each tire and set to the recommended pressure, if necessary.
2. Inspect the front wheel bearing play. Replace bearing (s) as necessary.
3. Inspect the wheel and tire runout of all wheels.
4. Inspect the ball joints and steering linkage for excessive looseness.
5. Place the vehicle on level ground with no luggage or passenger load.
6. The difference in height between the left and right sides from the center of the wheel to the fender brim must not exceed specification.

Specification: 10 mm { 0.39 in }

7. Shake the vehicle to settle the suspension.

FRONT WHEEL ALIGNMENT Specifications (Unladen)*1

Item		Specification
Maximum steering angle	Front	$40^{\circ} \pm 3^{\circ}$
	Rear	$33^{\circ} \pm 3^{\circ}$
Total toe-in	mm { in }	$2 \pm 4 \{ 0.08 \pm 0.16 \}$
	degree	$0^{\circ}12' \pm 0^{\circ}24'$
Camber angle*2		$-0^{\circ}44' \pm 1^{\circ}$
Caster angle*2	Fuel gauge indication	—
	Full	$1^{\circ}55' \pm 1^{\circ}$
	1/4	$1^{\circ}52' \pm 1^{\circ}$
	1/2	$1^{\circ}49' \pm 1^{\circ}$
	3/4	$1^{\circ}46' \pm 1^{\circ}$
	Empty	$1^{\circ}43' \pm 1^{\circ}$
Steering axis inclination		$13^{\circ}22'$

*1 Radiator coolant and engine oil at specified level; spare tire, jack, and tools in designated position. Adjust to the median when carrying out wheel alignment.

*2 Difference between left and right must not exceed 1.5° .

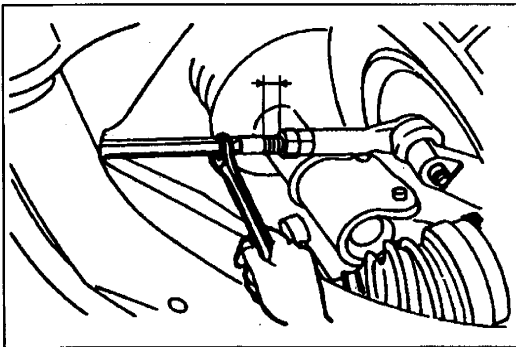

Maximum Steering Angle Adjustment

1. Remove the steering gear boot clamp.
2. Loosen the tie rod locknut.
3. Turn the tie rod to provide the correct maximum steering angle.

Maximum left/right difference: 3 mm { 0.12 in }

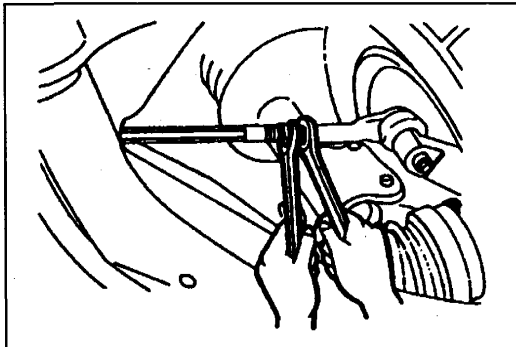

4. After adjustment, tighten the locknut to the specified torque.

Tightening torque:

35—50 N·m { 3.5—5.1 kgf·m , 26—36 ft·lbf }

5. Adjust the toe-in. (Refer to page R-5.)
6. Verify that the boot is not twisted, and install the boot clamp.

Caster/Camber Adjustment (camber)

Note

- Caster is not adjustable.
- Adjusting range is $47'$.

1. Jack up the vehicle and remove the wheel and tire.
2. Replace the bolt shown with an adjusting bolt.
3. Adjust the camber by moving the shock absorber and the knuckle.

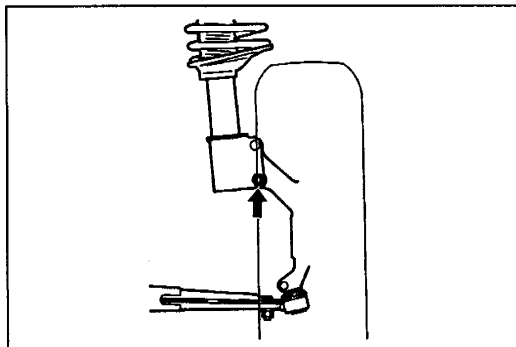

- Tighten the nut to the specified torque.

Tightening torque: 103—126 N·m
 { 10.5—12.9 kgf·m , 76.0—93.3 ft·lbf }

- Lower the vehicle after installing the wheel and tire.
- Inspect the camber.

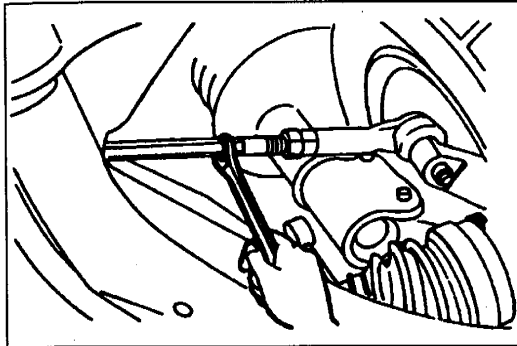

Total toe-in Adjustment

- Adjust the steering angle.
- Remove the steering gear boot clamp.
- Loosen the left and right tie rod locknuts and turn the tie rods equally. Both tie rods are right threaded, so turning the right tie rod toward the front of the vehicle and the left toward the rear increases toe-in.

Note

- Turning both tie rods one complete turn changes toe-in by about 12 mm { 0.47 in }.

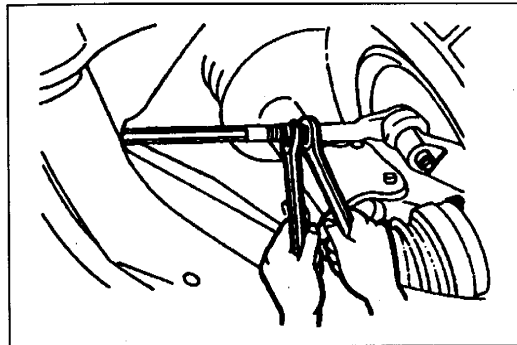

- Tighten the tie rod locknuts to the specified torque.

Tightening torque:
 35—50 N·m { 3.5—5.1 kgf·m , 26—36 ft·lbf }

R

- Verify that the boot is not twisted, and install the boot clamp.

REAR WHEEL ALIGNMENT Specifications (Unladen)*1

Item		Specifications
Total toe-in	mm { in }	2 ± 4 { 0.08 ± 0.16 }
	degree	0°12' ± 0°24'
Camber angle*2		-0°49' ± 1°
Thrust angle		0° ± 48'

*1 Fuel tank full; radiator coolant and engine oil at specified level; spare tire, jack, and tools in designated position. Adjust to the median when carrying out wheel alignment.

*2 Difference between left and right must not exceed 1.5°.

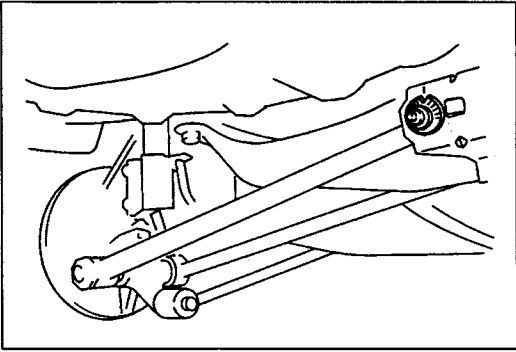
**Total toe-in
Adjustment**

In order to maintain the specified thrust angle of $0^\circ \pm 48'$, the rear toe-in setting must be adjusted. If the thrust angle cannot be adjusted to that specification, check the body dimensions.

1. Remove the cap.
2. Loosen the cam nut on the lateral link.
3. Turn the adjusting cam bolt to provide the correct total toe-in as indicated.
4. Tighten the cam nut.

Tightening torque:



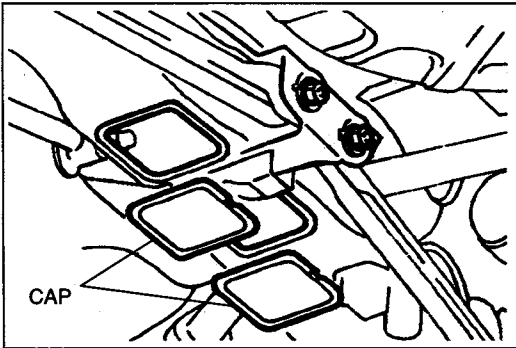

35—53 N·m { 3.5—5.5 kgf·m , 26—39 ft·lbf }

5. Install the cap.



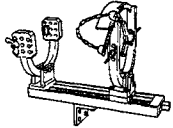

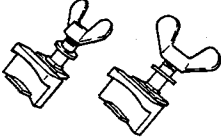
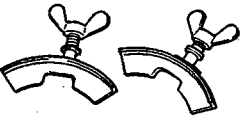
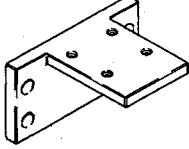
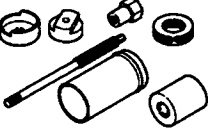
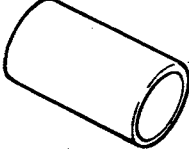

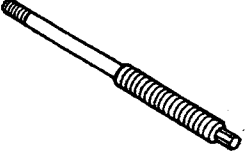
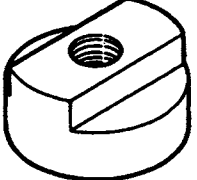
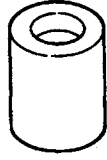
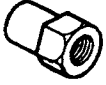
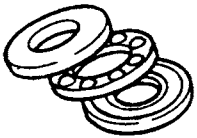
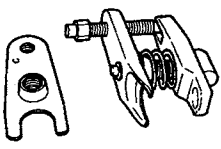
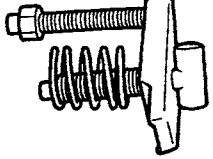

FRONT SUSPENSION (STRUT)

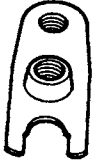
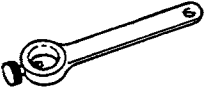
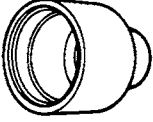
PREPARATION
SST

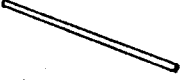
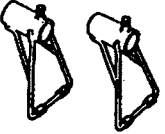
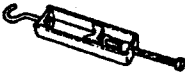
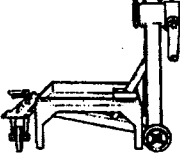
<p>49 T034 1A0 Compressor, coil spring</p> 	<p>For removal and installation of coil spring</p>	<p>49 T034 101 Compressor, spring (Part of 49 T034 1A0)</p> 	<p>For removal and installation of coil spring</p>
<p>49 T034 102 Stand (Part of 49 T034 1A0)</p> 	<p>For removal and installation of coil spring</p>	<p>49 T034 103 Hook (Part of 49 T034 1A0)</p> 	<p>For removal and installation of coil spring</p>
<p>49 T034 104 Support (Parts of 49 T034 1A0)</p> 	<p>For removal and installation of coil spring</p>	<p>49 T034 105 Attachment</p> 	<p>For removal and installation of coil spring</p>
<p>49 B034 2A1 Replacer, rubber bushing</p> 	<p>For removal and installation of lower arm bushing</p>	<p>49 B034 202 Support block (Part of 49 B034 2A1)</p> 	<p>For removal and installation of lower arm bushing</p>
<p>49 B034 203 Guide (Part of 49 B034 2A1)</p> 	<p>For removal and installation of lower arm bushing</p>	<p>49 B034 206 Shaft (Part of 49 B034 2A1)</p> 	<p>For removal and installation of lower arm bushing</p>
<p>49 B034 207 Replacer (Part of 49 B034 2A1)</p> 	<p>For removal and installation of lower arm bushing</p>	<p>49 B034 208 Attachment (Part of 49 B034 2A1)</p> 	<p>For removal and installation of lower arm bushing</p>
<p>49 W038 002 Nut (Part of 49 B034 2A1)</p> 	<p>For removal and installation of lower arm bushing</p>	<p>49 G034 205 Bearing (Part of 49 B034 2A1)</p> 	<p>For removal and installation of lower arm bushing</p>
<p>49 T028 3A0 Puller set, ball joint</p> 	<p>For removal of ball joint</p>	<p>49 T028 303 Body (Part of 49 T028 3A0)</p> 	<p>For removal of ball joint</p>

R

<p>49 T028 304</p> <p>Attachment (Part of 49 T028 3A0)</p>		<p>For removal of ball joint</p>	<p>49 0180 510B</p> <p>Attachment, preload measuring</p>		<p>For inspection of ball joint</p>
<p>49 1243 785</p> <p>Installer, boot</p>		<p>For installation of ball joint dust boot</p>	<p>49 G017 5A0</p> <p>Support, engine</p>		<p>For support of engine</p>
<p>49 G017 501</p> <p>Bar (Part of 49 G017 5A0)</p>		<p>For support of engine</p>	<p>49 G017 502</p> <p>Support (Parts of 49 G017 5A0)</p>		<p>For support of engine</p>
<p>49 G017 503</p> <p>Hook (Part of 49 G017 5A0)</p>		<p>For support of engine</p>	<p>49 0107 680A</p> <p>Engine stand</p>		<p>For removal and installation of coil spring</p>
<p>49 G034 1A0</p> <p>Compressor coil spring</p>		<p>For removal and installation of coil spring</p>	<p>49 G034 101</p> <p>Body (Part of 49 G034 1A0)</p>		<p>For removal and installation of coil spring</p>
<p>49 G034 102</p> <p>Screw (Part of 49 G034 1A0)</p>		<p>For removal and installation of coil spring</p>	<p>49 G034 103</p> <p>Arm (Part of 49 G034 1A0)</p>		<p>For removal and installation of coil spring</p>

FRONT SHOCK ABSORBER AND SPRING
Removal / Inspection

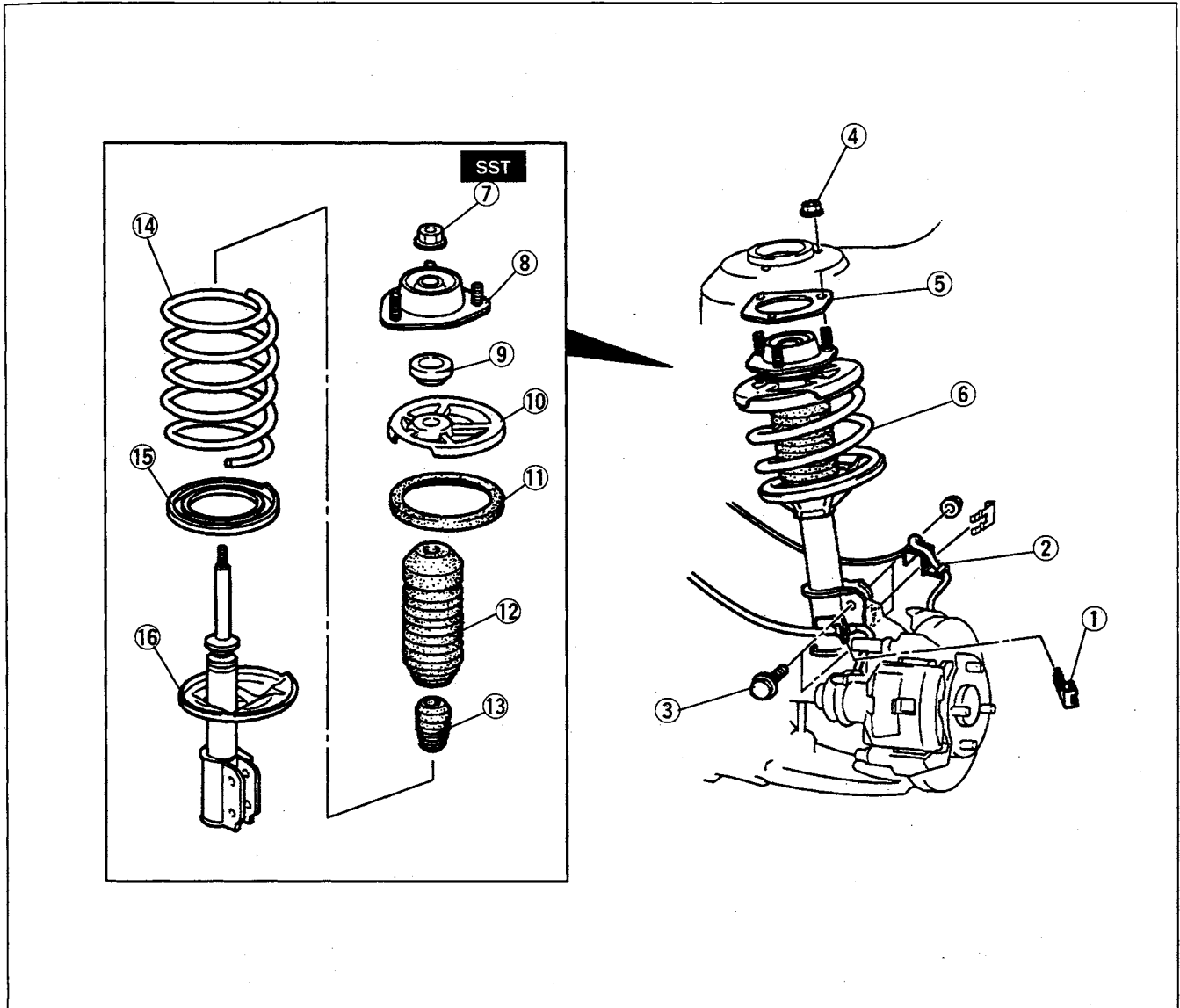

- | | |
|--|---|
| <p>1. Clip</p> <p>2. ABS wheel-speed sensor harness</p> <p>3. Bolt (shock absorber and spring)</p> <p>4. Nut</p> <p>5. Sheet</p> <p>6. Front shock absorber and spring</p> <p>7. Nut (mounting rubber)</p> <p>Removal Note</p> <p> When using SST
 (49 T034 1A0) page R-10</p> <p> When using SST
 (49 G034 1A0) page R-10</p> <p>8. Mounting rubber
 Inspect for damage, deterioration, and weakness</p> <p>9. Thrust bearing
 Inspect for damage, wear, and poor lubrication</p> | <p>10. Upper spring seat
 Inspect for damage and cracks</p> <p>11. Upper rubber spring seat
 Inspect for damage and deterioration</p> <p>12. Dust cover
 Inspect for damage and deterioration</p> <p>13. Bound stopper
 Inspect for damage and cracks</p> <p>14. Coil spring
 Inspect for damage, deterioration, and weakness</p> <p>15. Lower rubber spring seat
 Inspect for damage and cracks</p> <p>16. Front shock absorber
 Inspection page R-11
 Disposal of shock absorber page R-11</p> |
|--|---|

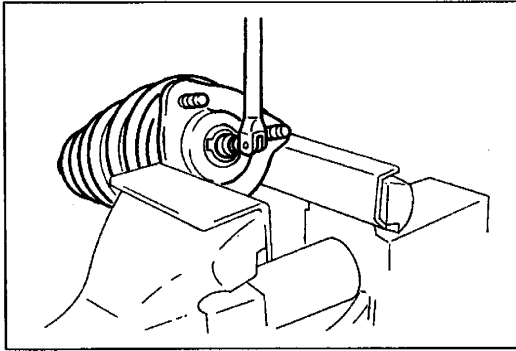

Removal note
Nut (mounting rubber)

Warning

- Removing the mounting rubber nut is dangerous. The shock absorber and spring could fly off under tremendous pressure and cause serious injury or death. Secure the shock absorber in the SST before removing the mounting rubber nut.

Caution

- To prevent damage to the mounting rubber, use protective plates in the jaws of the vise.

1. Secure the mounting rubber in a vise.
2. Loosen the nut several turns, but do not remove it.

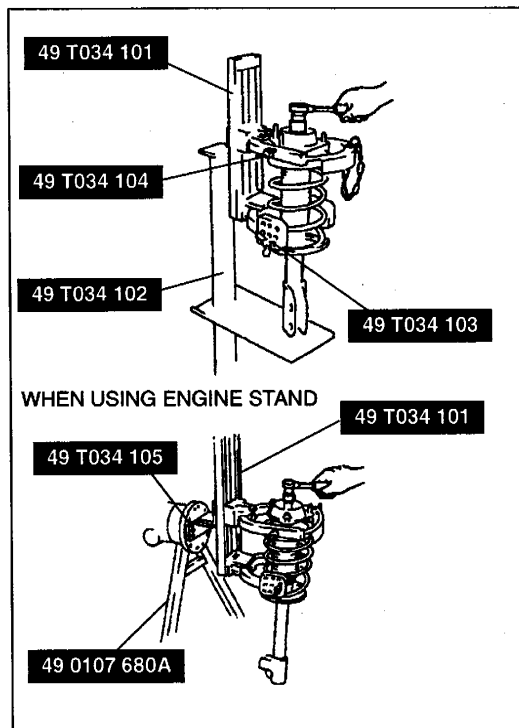

When using SST (49 T034 1A0)

3. Assemble the SSTs.
4. Secure the shock absorber in the SSTs.
5. Compress the coil spring by using the SSTs and remove the nut.

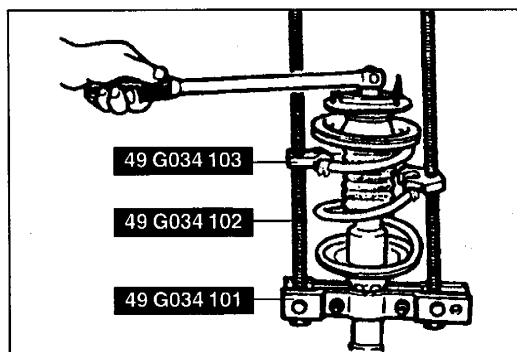

When using SST (49 G034 1A0)

3. Assemble the SSTs.
4. Compress the coil spring by using the SST and remove the nut.

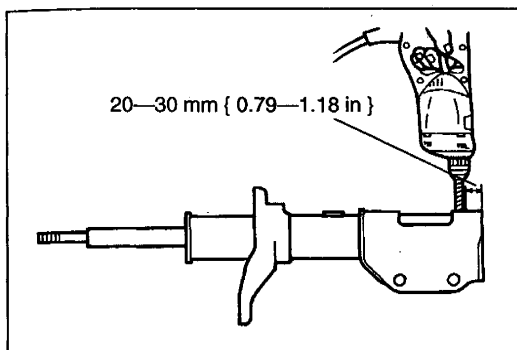
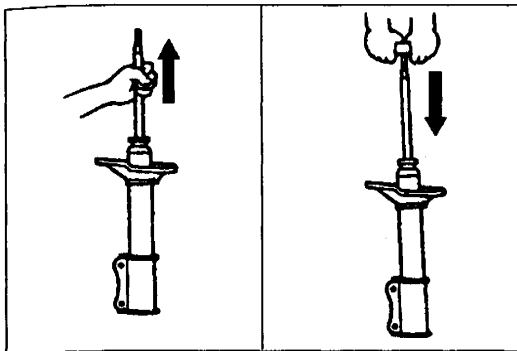
**Inspection****Front shock absorber**

Check for the following and replace the shock absorber if necessary.

1. Inspect for damage and oil leakage.
2. Secure a handle to the piston rod, and compress and expand the shock piston at least three times. Verify that the operational force does not change and that there is no unusual noise.

Disposal of shock absorber (if gas-charged)**Warning**

- The gas in the shock absorber is pressurized, and could spray metal chips into the eyes and face when drilling. Whenever drilling into a shock absorber, wear protective eye wear.

1. Clamp the shock absorber flat or with the piston downwards.
2. Drill a 2—3 mm { 0.08—0.12 in } hole at a point 20—30 mm { 0.79—1.18 in } from the bottom of the tube so that the gas can escape.
3. Turn the hole downwards.
4. The oil can be collected by moving the piston rod several times up and down and cutting the tube at the end.
5. Dispose of the waste oil according to the waste disposal law.

Note

- Shock absorber gas is nitrogen gas.
- Shock absorber oil is mineral oil.

Installation

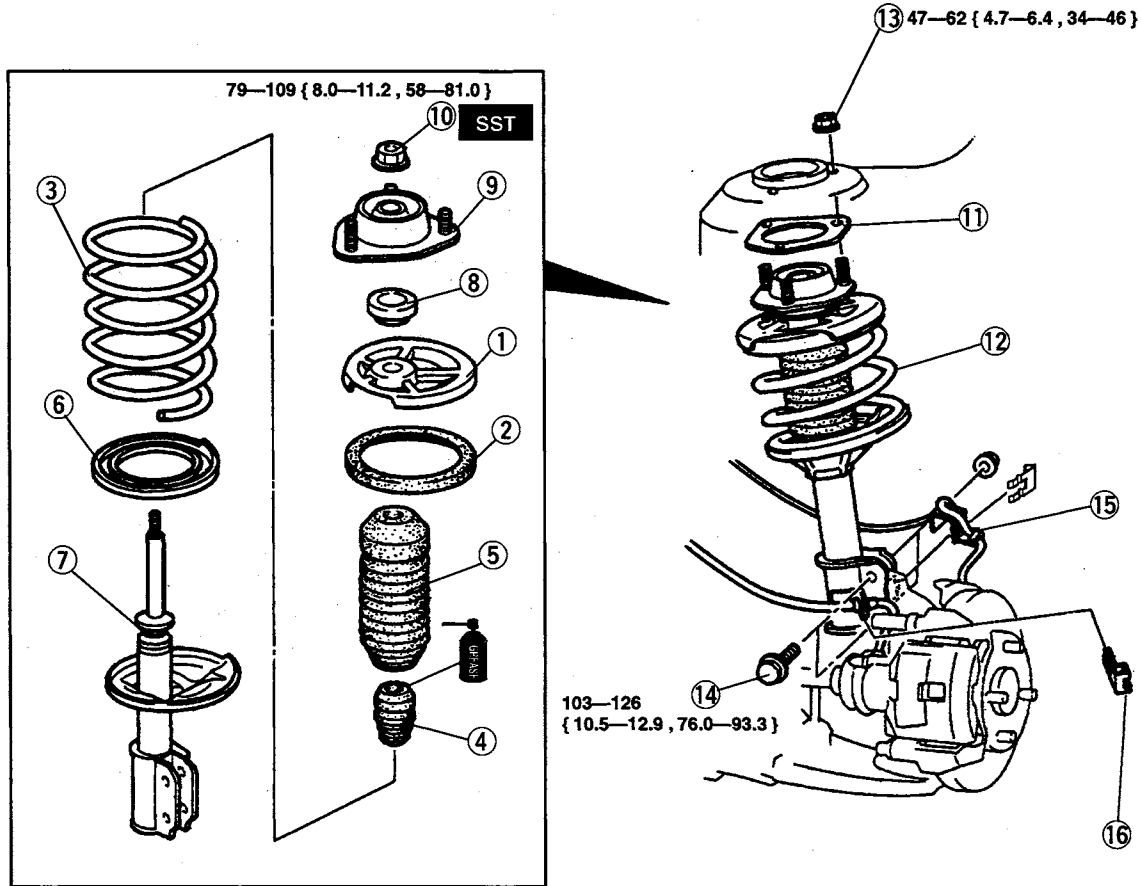

N·m { kgf·m, ft·lbf }

1. Upper spring seat
2. Upper rubber spring seat
3. Coil spring
6. Lower rubber spring seat
7. Front shock absorber
8. Thrust bearing
9. Mounting rubber
10. Nut (mounting rubber)
11. Sheet
12. Front shock absorber and spring
13. Nut
14. Bolt (shock absorber and spring)
15. ABS wheel-speed sensor harness
16. Clip

Installation Note

When using **SST**
(49 T034 1A0) page R-13

When using **SST**
(49 G034 1A0) page R-14

Installation Note page R-15

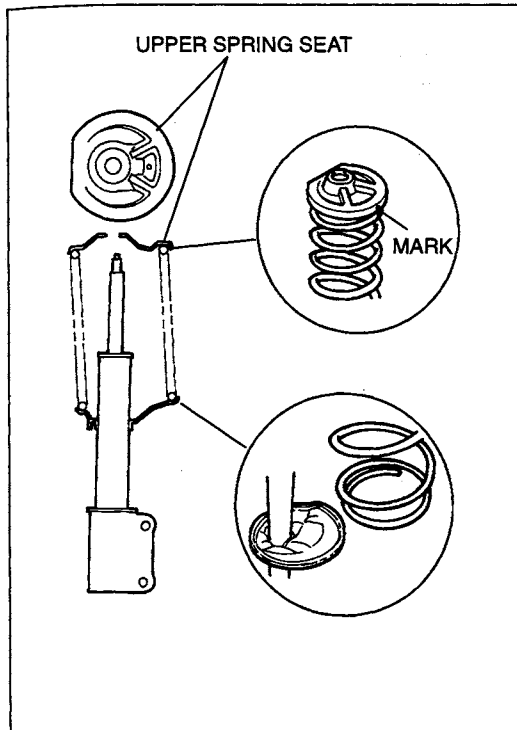
**Installation note****Coil spring****When using SST (49 T034 1A0)**

1. Temporarily assemble the upper rubber spring seat, the upper spring seat and coil spring to the shock absorber, as shown.
2. Mark the upper rubber spring seat, the upper spring seat, and coil spring for proper reassembly.

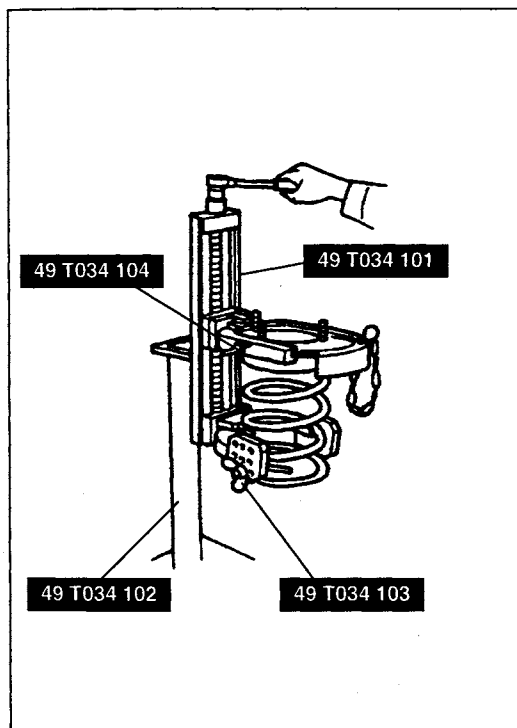

3. Align the marks of the upper spring seat and coil spring. Protect the upper spring seat and the coil spring with a piece of cloth; then assemble the **SSTs**.
4. Use the **SSTs** to compress the spring.
5. Install the bound stopper.
6. Install the dust cover.
7. Install the lower rubber spring seat.

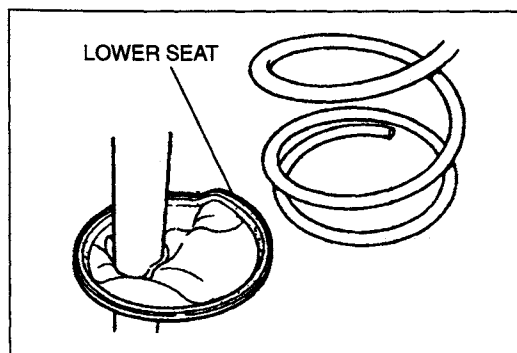

8. Install the shock absorber, fitting the end of the coil into the step of the lower seat.

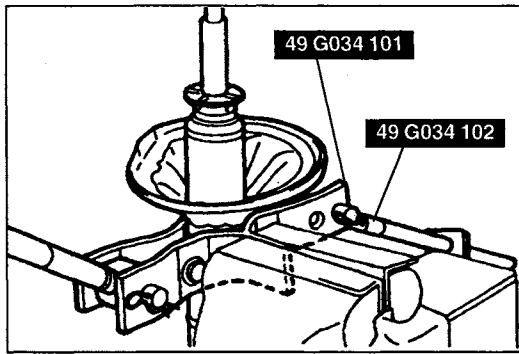

When using SST (49 G034 1A0)

1. Assemble the **SSTs**, and secure the **SSTs** in a vise.
2. Install the lower rubber spring seat.

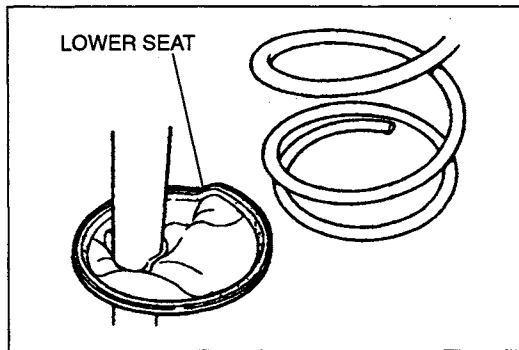

3. Install the coil spring, fitting the end of the coil into the step of the lower seat.

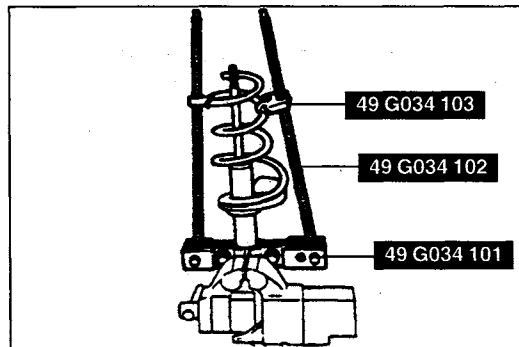

4. Use the **SSTs** to compress the spring.
5. Install the bound stopper.
6. Install the dust cover.

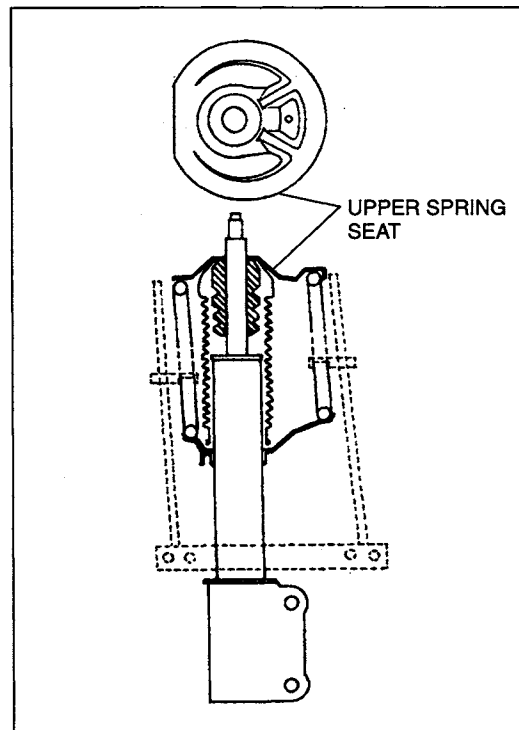

7. Install the upper spring seat to the shock absorber as shown.
8. Install the thrust bearing.

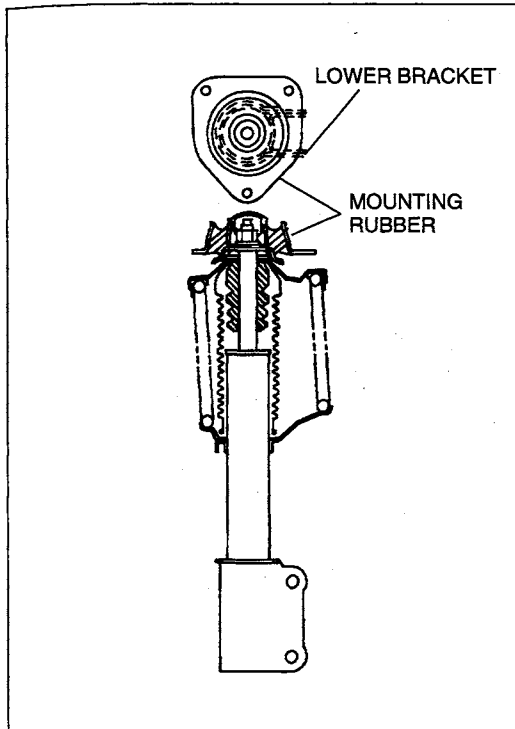
**Mounting rubber**

1. Install the mounting rubber, facing the direction indicator as shown.
2. Tighten the nut several turns.
3. Remove the **SST**.
4. Verify that the lower coil of the spring is seated on the step of the lower seat.

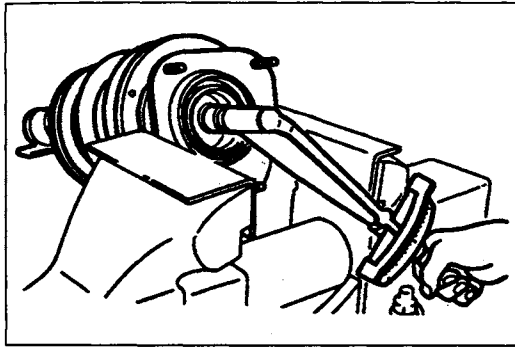
**Caution**

- To prevent damage to the mounting rubber, use protective plates in the jaws of the vise.

5. Secure the mounting rubber in a vise.
6. Tighten the nut.

Tightening torque:

79—109 N·m { 8.0—11.2 kgf·m , 58—81.0 ft·lbf }

FRONT LOWER ARM

Removal / Inspection / Installation

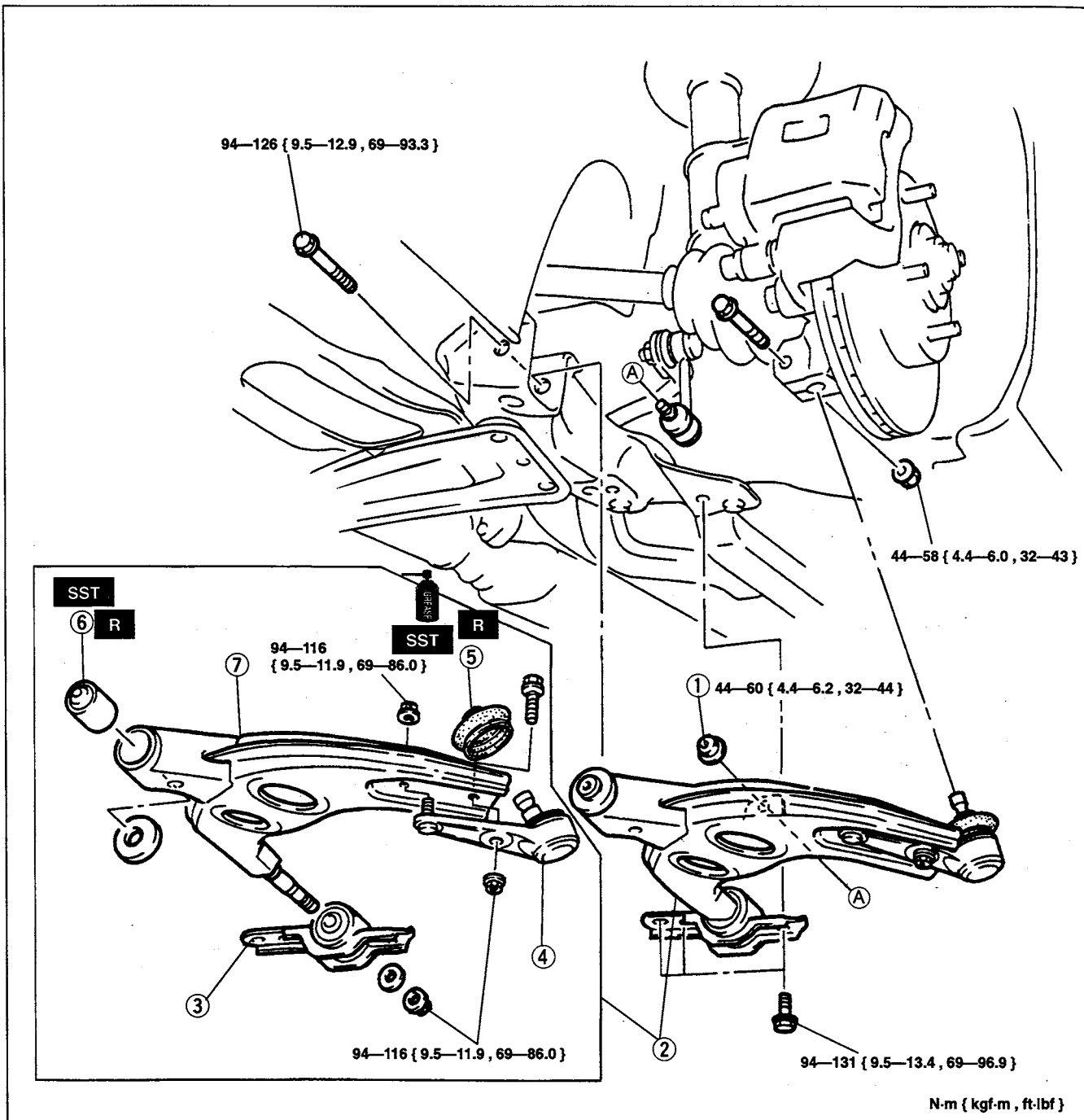

1. Nut (stabilizer control link)
2. Front lower arm assembly
3. Lower arm bushing (rear)
Inspect for damage, oil leakage, and deterioration
4. Lower arm ball joint
Inspection page R-17
5. Dust boot
Inspect for damage, stiffness, and deterioration
Removal Note page R-17
Installation Note page R-18
6. Lower arm bushing (front)
Inspect for damage and deterioration
Removal Note page R-17
Installation Note page R-17
7. Front lower arm
Inspect for damage and cracks

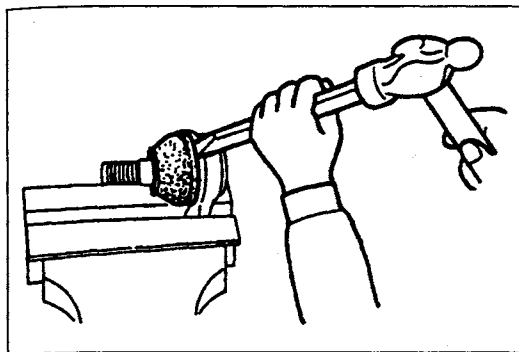

Removal note

Dust boot

Remove the dust boot by using a chisel.

Caution

- Do not damage the ball joint.

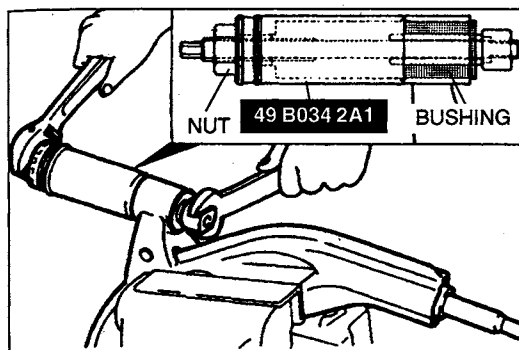

Lower arm bushing (front)

1. Cut away the projecting rubber of the lower arm bushing.
2. Set the SST to the lower arm and remove the bushing.

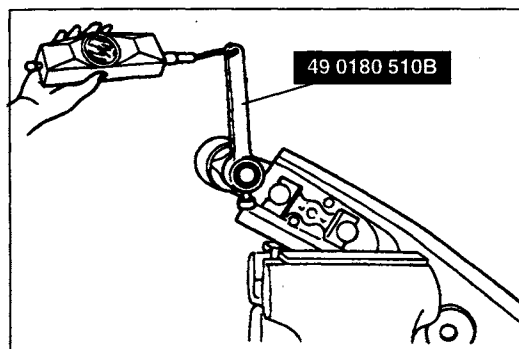

Inspection

Lower arm ball joint

1. Inspect ball joint body for damage and boot for cracks, and replace as necessary.
2. Inspect the ball joint for looseness and damage and replace as necessary.
3. Measure the ball joint preload.
Shake and rotate the ball joint stud 5 times before measuring the preload. Attach the SST to the ball stud, and measure the preload by using a pull scale.

Ball joint preload:

1.0—4.9 N·m { 10—50 kgf·cm , 8.7—43 in·lbf }

Pull scale reading:

10—49 N { 1.0—5.0 kgf , 2.2—11 lbf }

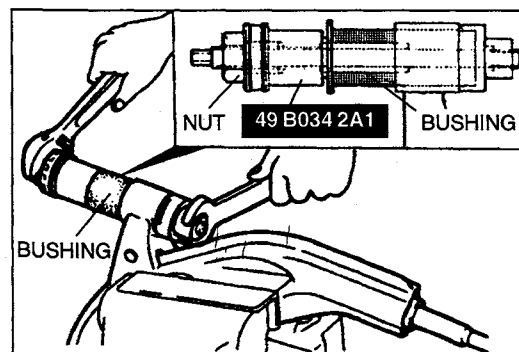

Installation note

Lower arm bushing (front)

1. Apply soapy water to the new bushing.
2. Pull the new bushing into the lower arm by using the SST.

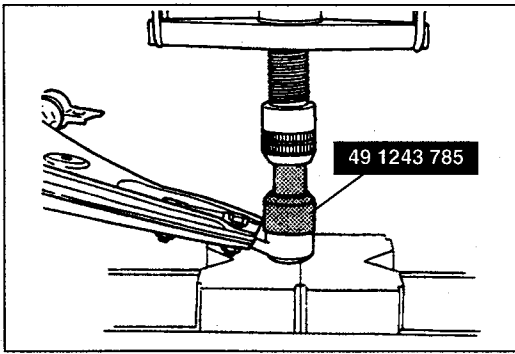
**Dust boot**

1. Wipe the grease off the ball stud.
2. Fill the inside of the new dust boot with grease.
3. Press the boot onto the ball joint by using the **SST**.
4. Wipe away the excess grease.

FRONT STABILIZER
Removal / Inspection / Installation

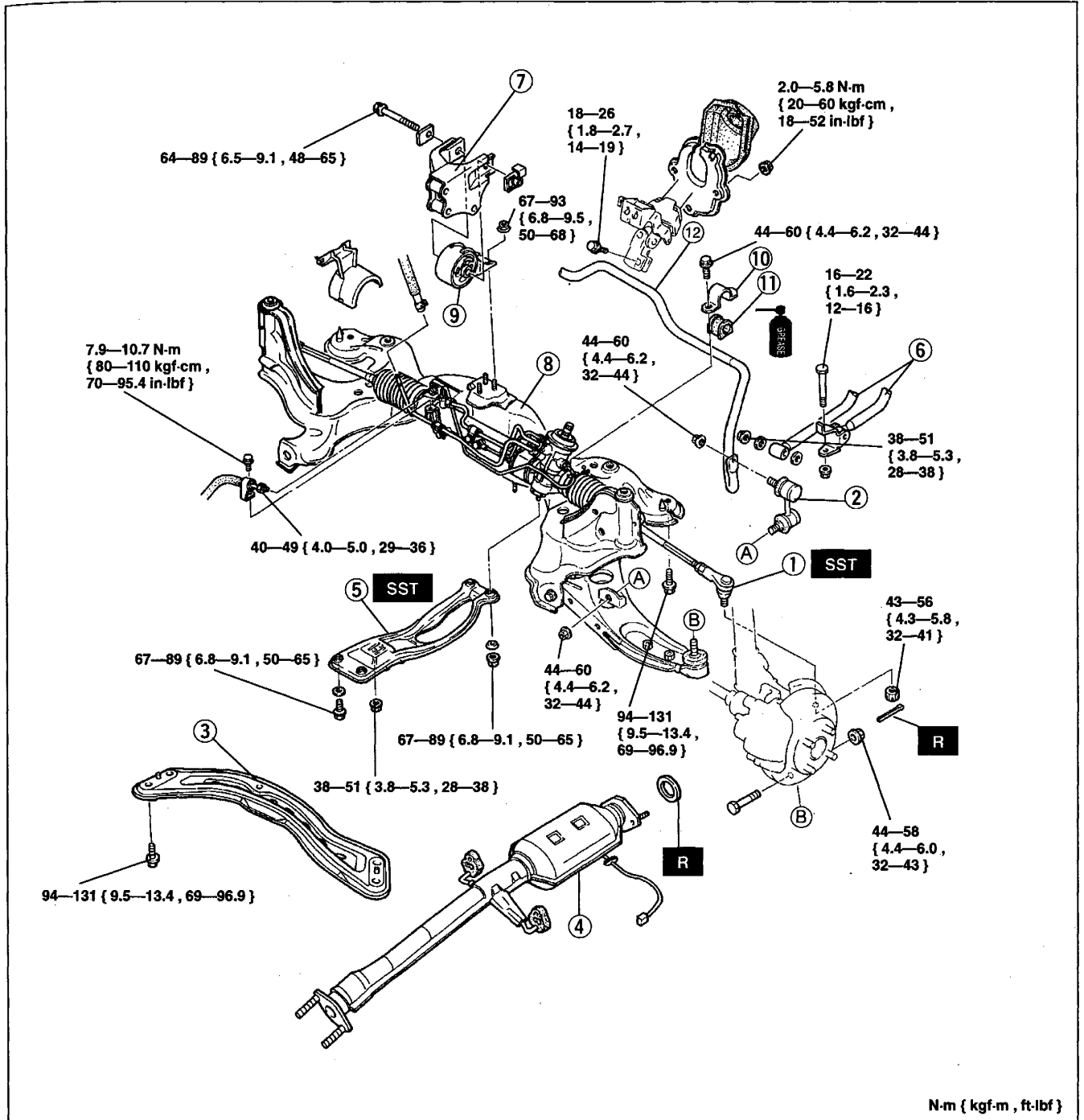

N-m { kgf-m , ft-lbf }

- | | |
|---|--|
| <p>1. Tie-rod end
Service section N</p> <p>2. Stabilizer control link
Inspection page R-20</p> <p>3. Transverse member</p> <p>4. Three-way catalytic converter</p> <p>5. Engine mounting member
Removal Note page R-20</p> <p>6. Change control rod and extension bar (MTX)</p> <p>7. No.1 engine mount bracket</p> | <p>8. Lower arm, front crossmember, and steering gear assembly
Removal Note page R-20</p> <p>9. No.1 engine mount</p> <p>10. Stabilizer bracket
Installation Note page R-20</p> <p>11. Stabilizer bushing
Inspect for damage and weakness
Installation Note page R-20</p> <p>12. Front stabilizer bar
Inspect for damage and deformation</p> |
|---|--|

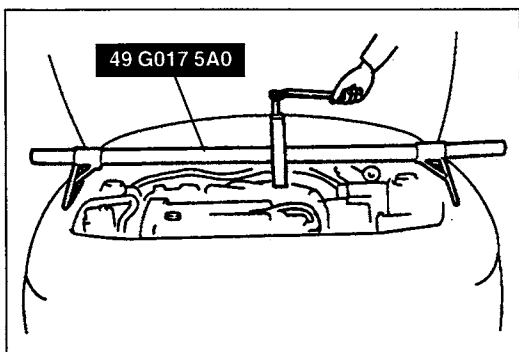
**Removal note****Engine mounting member**

1. Support the engine by using the SST.
2. Remove the engine mounting member nuts.

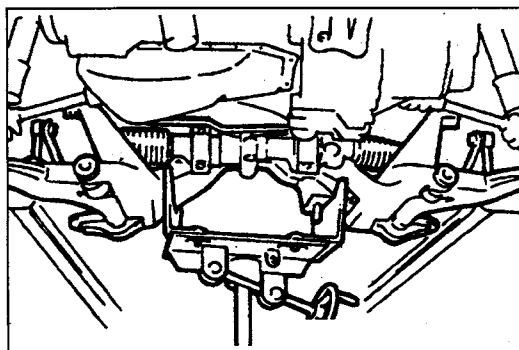
**Lower arm, front crossmember, and steering gear assembly**

1. Support the crossmember by using a jack and remove the bolts and nuts.

Caution

- Do not let the crossmember fall.

2. Remove the lower arm, the front crossmember, and steering gear assembly.

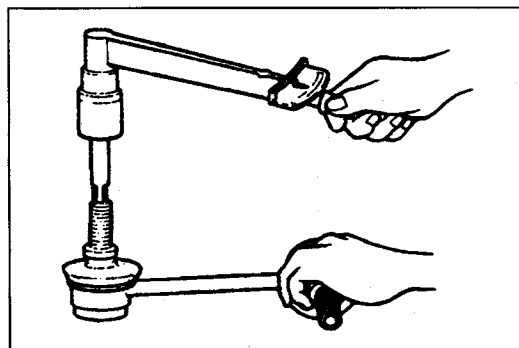
**Inspection****Stabilizer control link**

Check the following and replace if necessary.

1. Inspect for bending and damage.
2. Measure the ball joint starting torque.
 - (a) Rock the ball joint stud side to side 10 times..
 - (b) Rotate the ball joint stud 10 times.
 - (c) Measure the starting torque by using a suitable Allen socket and a torque wrench.

Starting torque:

0.1—1.9 N·m { 1—20 kgf·cm , 0.9—17 in·lbf }

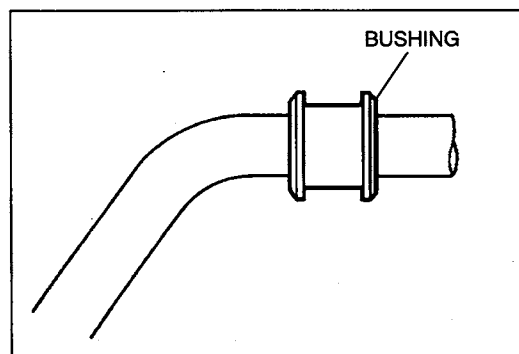
**Installation note****Stabilizer bushing and bracket**

1. Apply rubber grease to the inside surface of the stabilizer bushing.

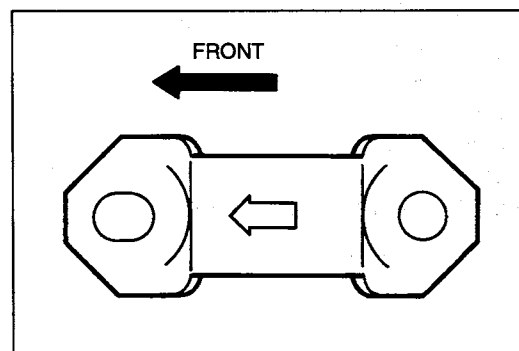

2. Install the stabilizer bracket in the direction shown.

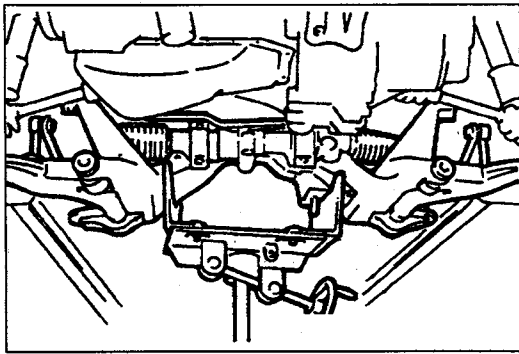

Removal note

Front crossmember and steering gear assembly

1. Support the crossmember by using a jack and remove the bolts and nuts.

Caution

- Do not let the crossmember fall.

2. Remove the front crossmember and steering gear assembly.

REAR SUSPENSION (STRUT)

PREPARATION

SST

49 T034 1A0 Compressor, coil spring		For removal and installation of coil spring	49 T034 101 Compressor, spring (Part of 49 T034 1A0)		For removal and installation of coil spring
49 T034 102 Stand (Part of 49 T034 1A0)		For removal and installation of coil spring	49 T034 103 Hook (Part of 49 T034 1A0)		For removal and installation of coil spring
49 T034 104 Support (Parts of 49 T034 1A0)		For removal and installation of coil spring	49 T034 105 Attachment		For removal and installation of coil spring
49 G034 1A0 Compressor, coil spring		For removal and installation of coil spring	49 G034 101 Body (Part of 49 G034 1A0)		For removal and installation of coil spring
49 G034 102 Screw (Part of 49 G034 1A0)		For removal and installation of coil spring	49 G034 103 Arm (Part of 49 G034 1A0)		For removal and installation of coil spring
49 0107 680A Engine stand		For removal and installation of coil spring		—	—

REAR SHOCK ABSORBER AND SPRING

Removal / Inspection

1. Remove the trunk side trim before service operation. (Refer to section S1.)
2. Install the trunk side trim after service operation. (Refer to section S1.)

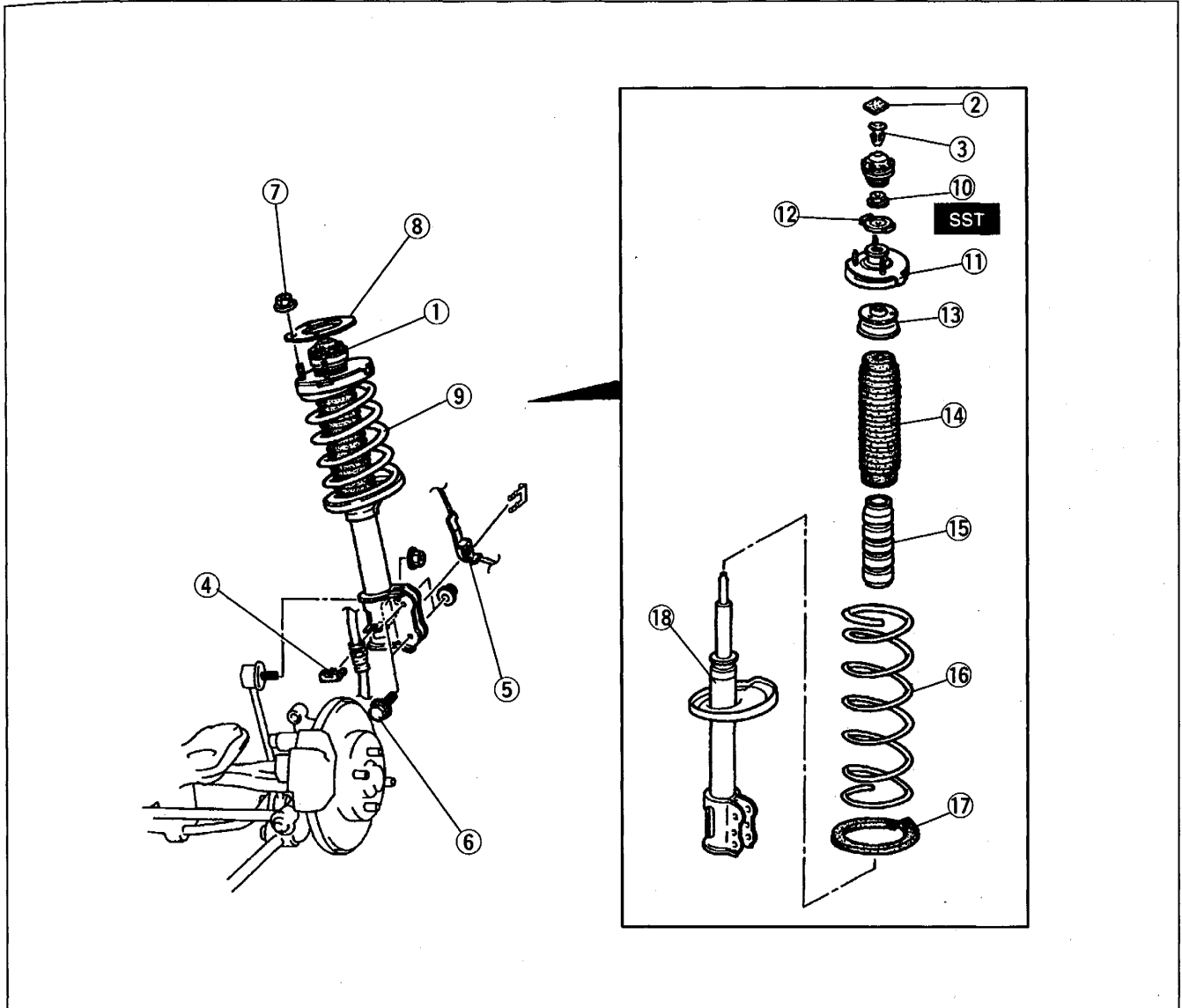

- | | |
|---|--|
| <ol style="list-style-type: none"> 1. Cap 2. Sponge 3. Fastener 4. Clip 5. ABS wheel-speed sensor harness 6. Shock absorber bolt 7. Nut 8. Sheet 9. Rear shock absorber and spring 10. Nut (mounting rubber) <p>Removal Note</p> <p>When using SST
(49 T034 1A0) page R-24</p> <p>When using SST
(49 G034 1A0) page R-24</p> <ol style="list-style-type: none"> 11. Mounting rubber <p>Inspect for damage and weakness</p> | <ol style="list-style-type: none"> 12. Washer 13. Upper spring seat <p>Inspect for damage and weakness</p> <ol style="list-style-type: none"> 14. Dust cover <p>Inspect for damage and cracks</p> <ol style="list-style-type: none"> 15. Bound stopper <p>Inspect for damage and cracks</p> <ol style="list-style-type: none"> 16. Coil spring <p>Inspect for damage and weakness</p> <ol style="list-style-type: none"> 17. Lower spring seat <p>Inspect for damage and weakness</p> <ol style="list-style-type: none"> 18. Rear shock absorber <p>Inspection page R-24</p> <p>Disposal of shock absorber page R-25</p> |
|---|--|

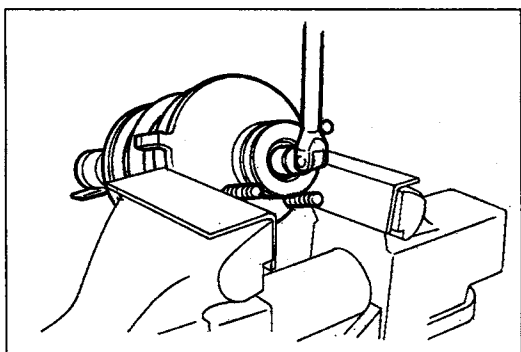

Removal note
Nut (mounting rubber)

Warning

- Removing the mounting rubber nut is dangerous. The shock absorber and spring could fly off under tremendous pressure and cause serious injury or death. Secure the shock absorber in the SST before removing the mounting rubber nut.

Caution

- To prevent damage to the mounting rubber, use protective plates in the jaws of the vise.

1. Secure the mounting rubber in a vise.
2. Loosen the nut several turns, but do not remove it.

When using SST (49 T034 1A0)

3. Assemble the SSTs.
4. Secure the shock absorber in the SSTs.
5. Compress the coil spring by using the SSTs and remove the nut.

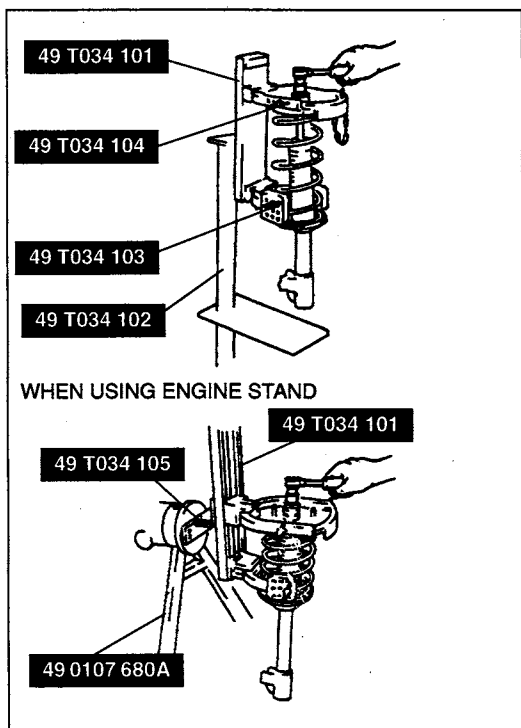

When using SST (49 G034 1A0)

3. Assemble the SSTs.
4. Compress the coil spring by using the SST and remove the nut.

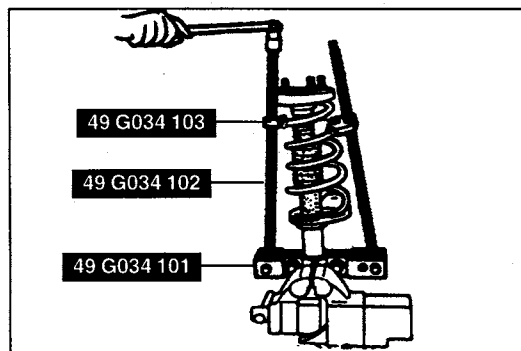

Inspection

Rear shock absorber

Check for the following and replace the shock absorber if necessary.

1. Inspect for damage and oil leakage.
2. Secure a handle to the piston rod, and compress and expand the shock piston at least three times. Verify that the operational force does not change and that there is no unusual noise.

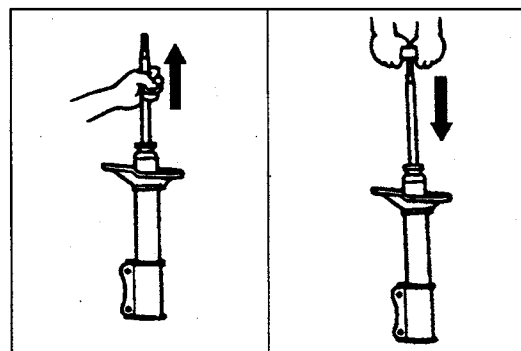

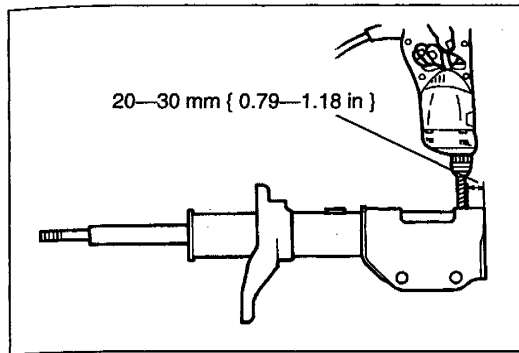
**Disposal of shock absorber (if gas-charged)****Warning**

- The gas in the shock absorber is pressurized, and could spray metal chips into the eyes and face when drilling. Whenever drilling into a shock absorber, wear protective eye wear.

1. Clamp the shock absorber flat or with the piston downwards.
2. Drill a 2—3 mm { 0.08—0.12 in } hole at a point 20—30 mm { 0.79—1.18 in } from the bottom of the tube so that the gas can escape.
3. Turn the hole downwards.
4. The oil can be collected by moving the piston rod several times up and down and cutting the tube at the end.
5. Dispose of the waste oil according to the waste disposal law.

Note

- Shock absorber gas is nitrogen gas.
- Shock absorber oil is mineral oil.

Installation

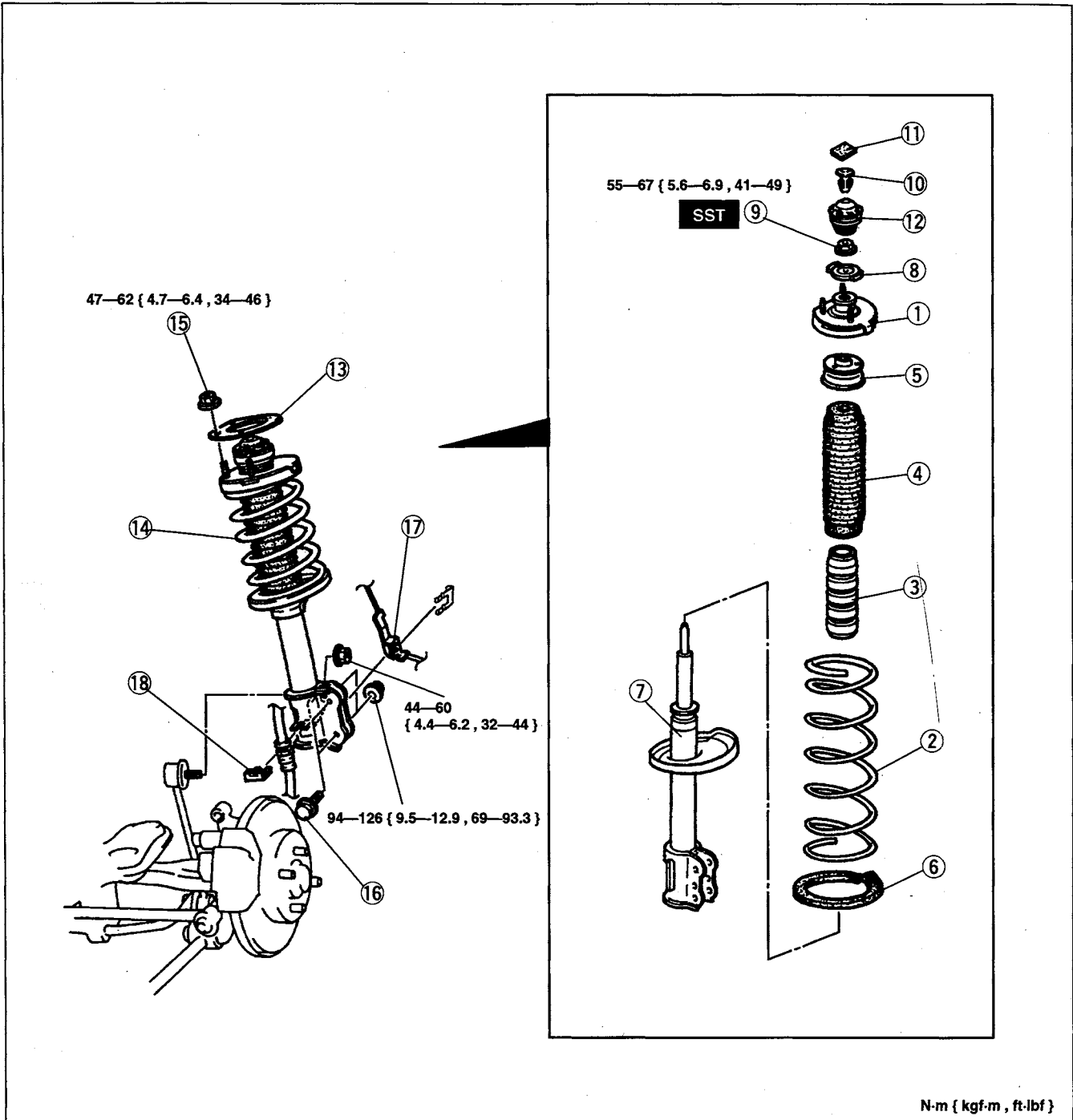

1. Mounting rubber

2. Coil spring

Installation Note

When using SST

(49 T034 1A0) page R-27

When using SST

(49 G034 1A0) page R-28

3. Bound stopper

4. Dust cover

5. Upper spring seat

6. Lower spring seat

7. Rear shock absorber

8. Washer

9. Nut (mounting rubber)

Installation Note page R-29

10. Fastener

11. Sponge

12. Cap

13. Sheet

14. Rear shock absorber and spring

15. Nut

16. Shock absorber bolt

17. ABS wheel-speed sensor harness

18. Clip

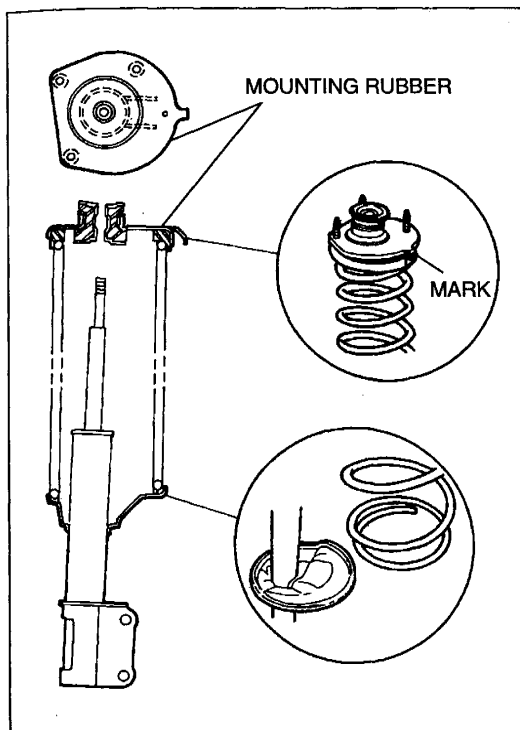

Installation note

Coil spring

When using SST (49 T034 1A0)

1. Temporarily assemble the upper spring seat, the mounting rubber, and coil spring to the shock absorber, as shown.
2. Mark the upper spring seat and coil spring for proper reassembly.

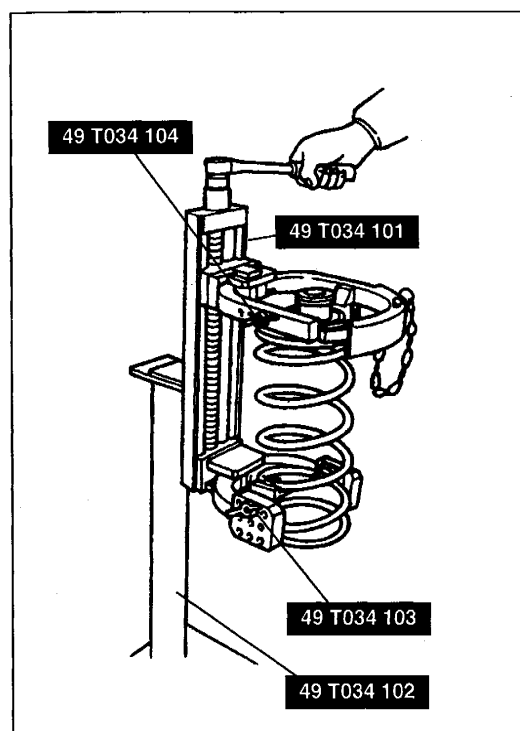

3. Align the marks of the upper spring seat and coil spring. Protect the upper spring seat and the coil spring with a piece of cloth; then assemble the **SSTs**.
4. Use the **SSTs** to compress the spring.

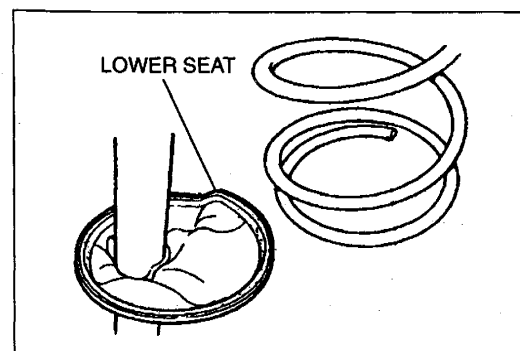

5. Install the lower spring seat.
6. Install the bound stopper.
7. Install the dust cover.
8. Install the shock absorber, fitting the end of the coil into the step of the lower seat.

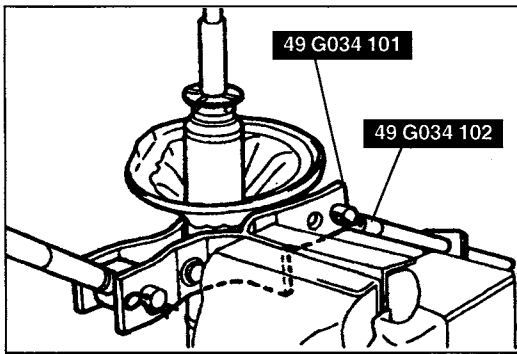

When using SST (49 G034 1A0)

1. Assemble the **SSTs**, and secure the **SSTs** in a vise.
2. Install the lower rubber spring seat.

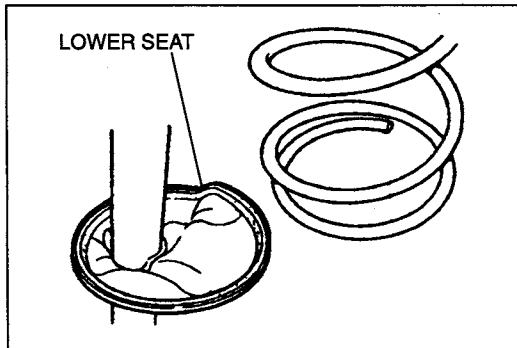

3. Install the coil spring, fitting the end of the coil into the step of the lower seat.

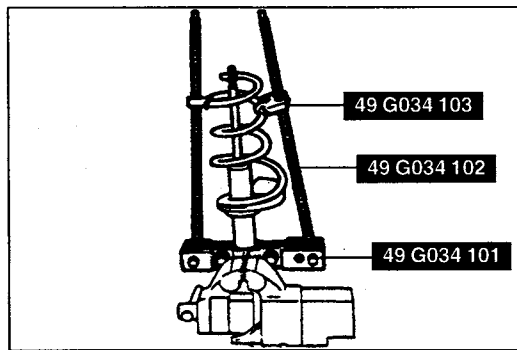

4. Use the **SSTs** to compress the spring.
5. Install the bound stopper.
6. Install the dust cover.

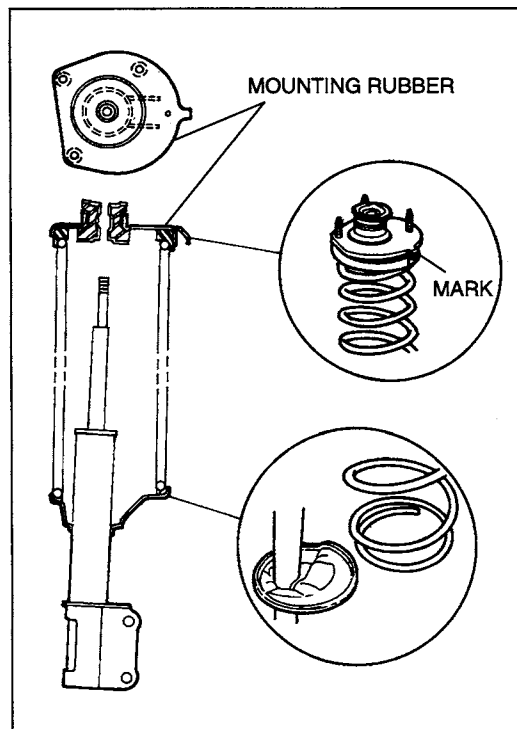

7. Install the mounting rubber to the shock absorber as shown.

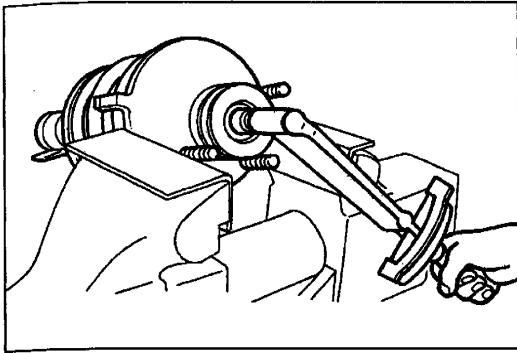
**Nut (mounting rubber)**

1. Tighten the nut several turns.
2. Remove the **SST**.
3. Verify that the lower coil of the spring is properly seated on the step of the lower seat.

Caution

- To prevent damage to the mounting rubber, use protective plates in the jaws of the vise.

4. Secure the mounting rubber in a vise.
5. Tighten the nut.

Tightening torque:

55—67 N·m { 5.6—6.9 kgf·m , 41—49 ft·lbf }

LATERAL LINK AND TRAILING LINK Removal / Inspection / Installation

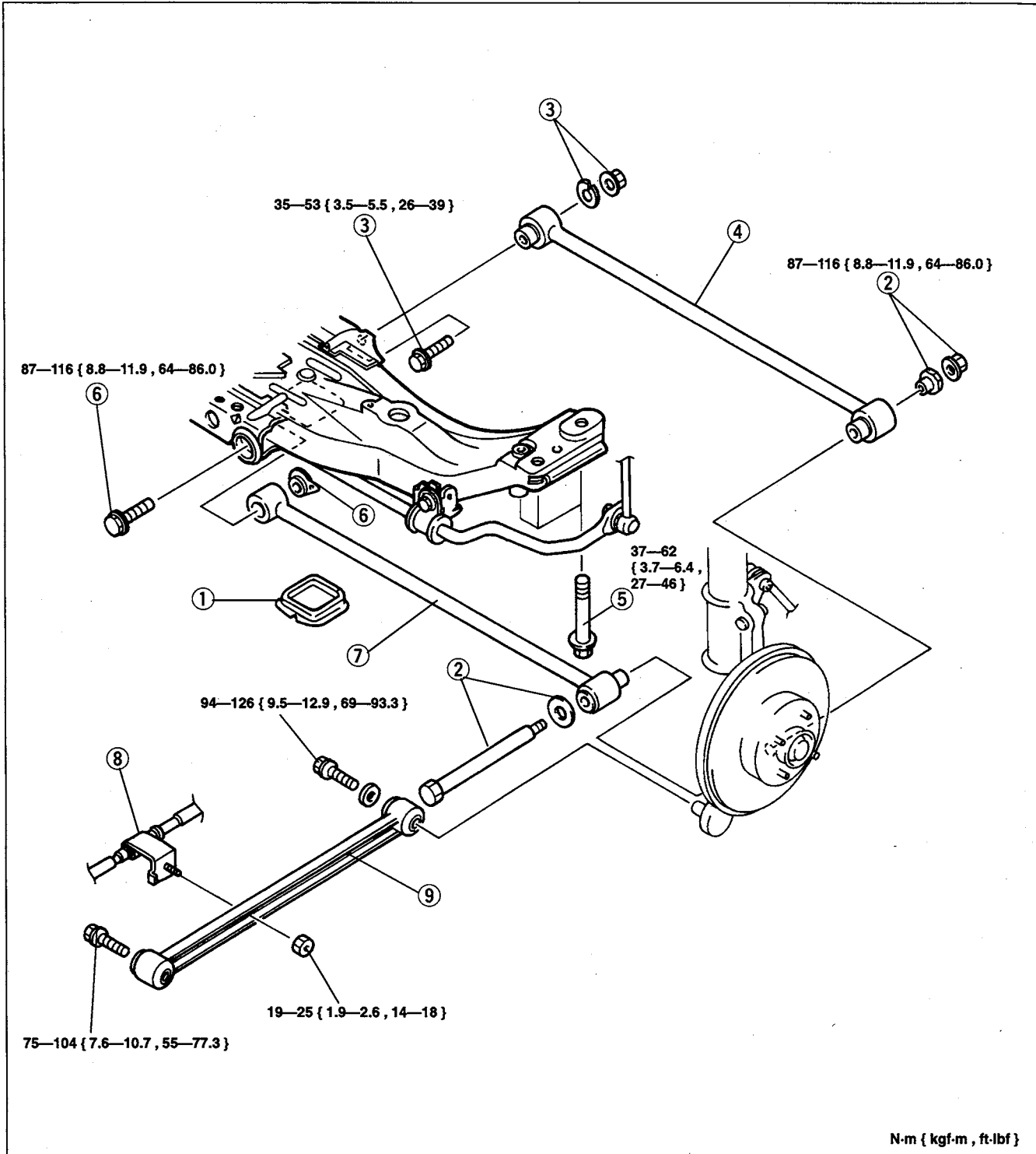

1. Cap
2. Bolt, washer, and nut
3. Nut, cam plate, and adjusting cam bolt
Removal Note page R-31
Installation Note page R-31
4. Lateral link (rear)
Inspect for deformation
Inspect bushing for damage

5. Bolt (crossmember)
Removal Note page R-31
6. Bolt and nut
7. Lateral link (front)
8. Brake cable bracket
9. Trailing link
Inspect for deformation
Inspect bushing for damage

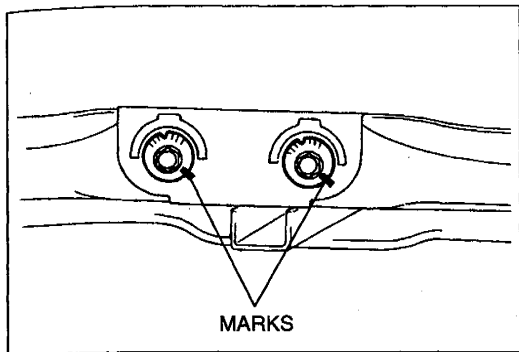

Removal note

Nut, cam plate, and adjusting cam bolt

Before loosening the nut, make a mark on the cam plate and the crossmember for reference during installation.

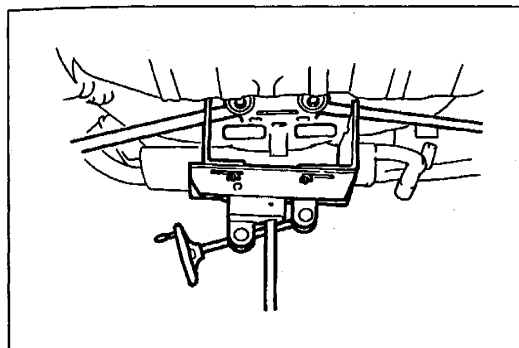

Bolt (crossmember)

Support the crossmember by using a jack and remove the bolts.

Caution

- Do not let the crossmember fall.

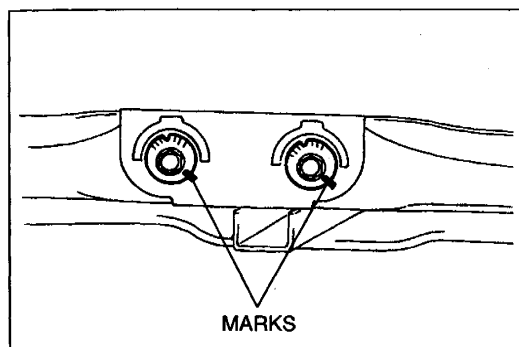

Installation note

Nut, cam plate, and adjusting cam bolt

1. Install the cam plate so that the notch faces the same direction as the adjusting cam bolt.
2. Align to the mark made before removing the adjusting cam bolt.

REAR STABILIZER Removal / Inspection / Installation

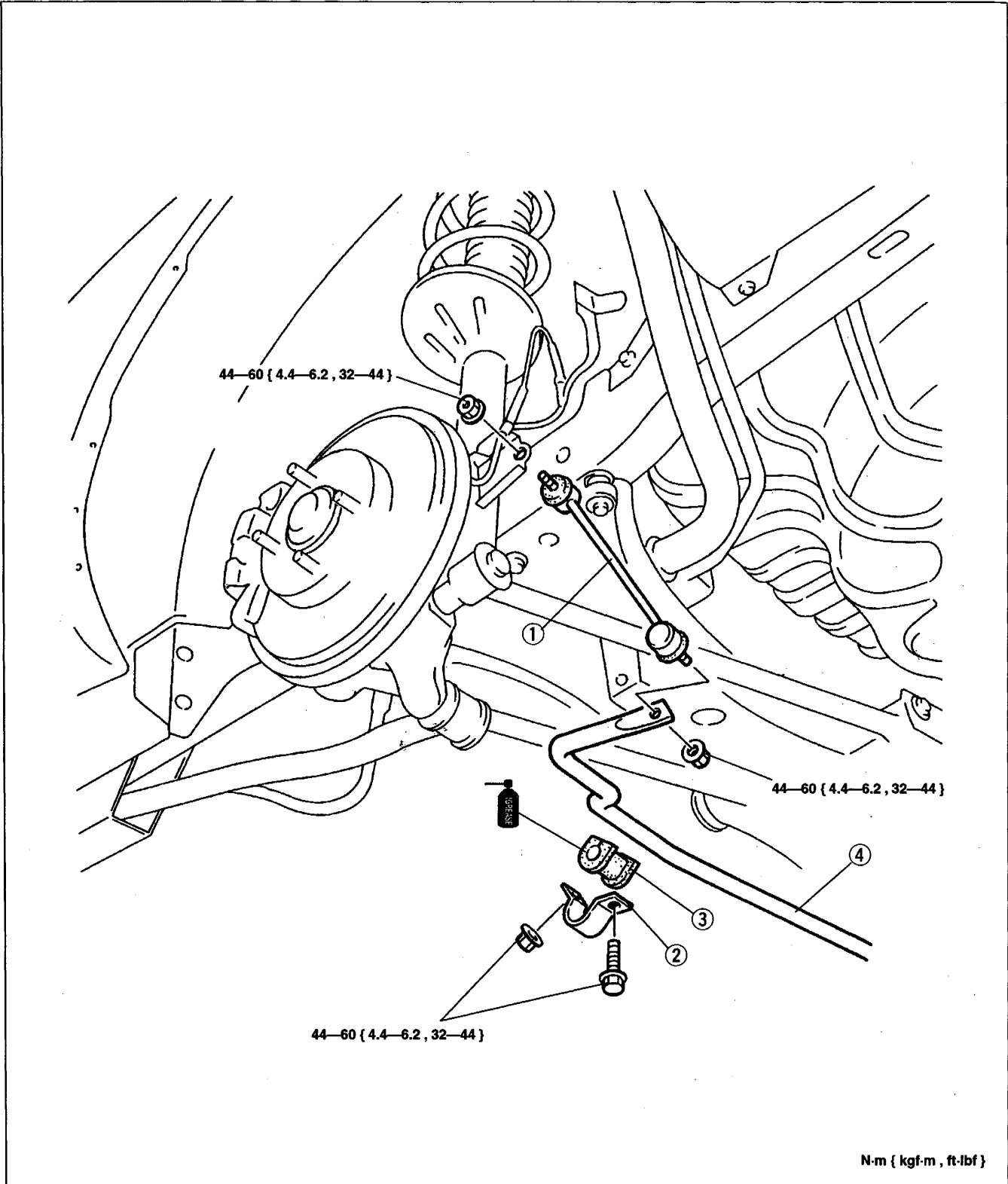

- 1. Stabilizer control link
Inspection page R-33
- 2. Stabilizer bracket
Installation Note page R-33

- 3. Stabilizer bushing
Inspect for damage and weakness
Installation Note page R-33
- 4. Rear stabilizer bar
Inspect for damage and deformation

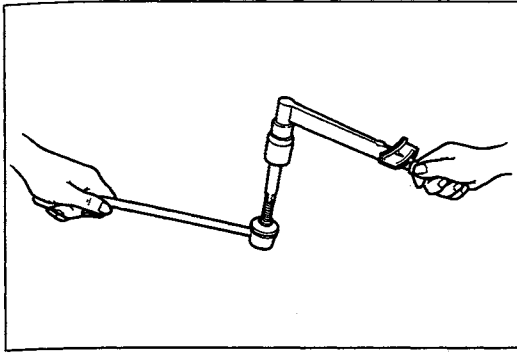

Inspection

Check the following and replace if necessary.

Stabilizer control link

1. Inspect for bending and damage.
2. Measure the ball joint starting torque.
 - (a) Rock the ball joint stud side to side 10 times.
 - (b) Rotate the ball joint stud 10 times.
 - (c) Measure the starting torque by using a suitable Allen socket and a torque wrench.

Starting torque:

0.1—1.9 N·m { 1—20 kgf·cm , 0.9—17 in·lbf }

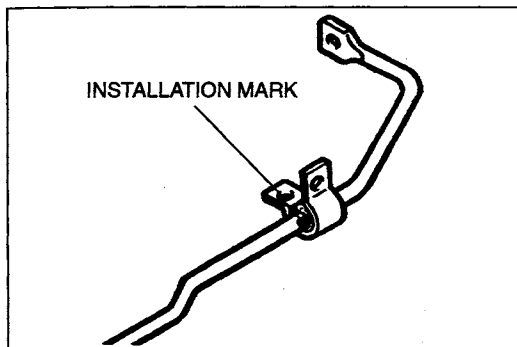

Installation note

Stabilizer bushing and bracket

1. Apply rubber grease to the inside surface of the stabilizer bushing.
2. Align the bushing with the installation mark on the stabilizer bar.

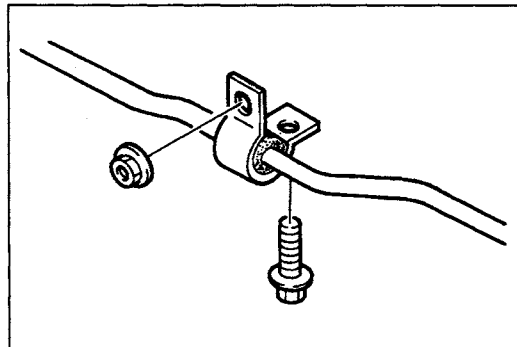

3. Install the stabilizer bracket with the elliptical hole under-side.
4. After temporarily tightening the bolt and nut, tighten the bolt and nut in turn.

REAR CROSSMEMBER Removal / Inspection / Installation

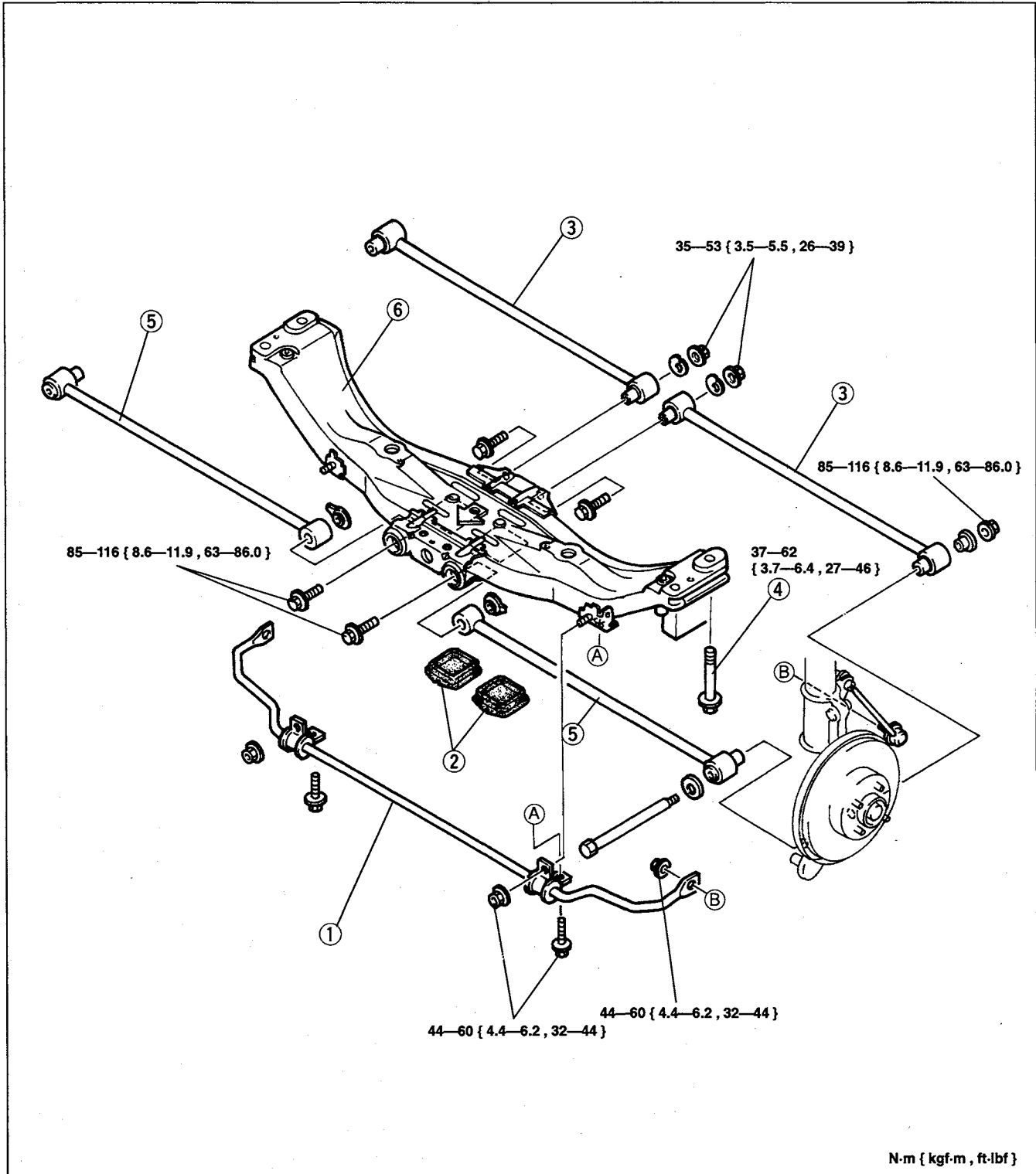

1. Rear stabilizer bar
Removal / Inspection /
Installation page R-32
2. Cap
3. Lateral link (rear)
Removal / Inspection /
Installation page R-30

4. Bolt (crossmember)
Removal Note page R-31
5. Lateral link (front)
Removal / Inspection /
Installation page R-30
6. Rear crossmember
Inspect for damage and cracks

Before beginning any service procedure, refer to section T1 of this manual for air bag system service warnings.

BODY

(4 DOOR SEDAN)

HOOD	S1- 3	RADIATOR GRILLE	S1-42
HOOD	S1- 3	RADIATOR GRILLE	S1-42
HOOD LOCK AND OPENER	S1- 5	GRILLE LOWER MOLDING	S1-43
HOOD LOCK AND OPENER	S1- 5	SIDE GARNISH	S1-44
FRONT FENDER PANEL	S1- 7	SIDE PROTECTOR	S1-44
FRONT FENDER PANEL	S1- 7	STONE GUARD	S1-46
DOOR	S1- 8	EXTRACTOR CHAMBER	S1-47
FRONT DOOR	S1- 8	EXTRACTOR CHAMBER	S1-47
REAR DOOR	S1- 9	REAR FINISHER	S1-48
WINDOW REGULATOR, GLASS AND		REAR END EXTENSION	S1-48
GUIDE	S1-11	MOLDING	S1-49
STRUCTURAL VIEW	S1-11	PREPARATION	S1-49
FRONT WINDOW REGULATOR AND		WINDSHIELD MOLDING	S1-49
GLASS	S1-12	REAR WINDOW MOLDING	S1-52
REAR WINDOW REGULATOR, GLASS		FRONT BELTLINE MOLDING	S1-53
AND GUIDE	S1-14	REAR BELTLINE MOLDING	S1-54
POWER WINDOW REGULATOR ..	S1-16	ROOF MOLDING	S1-55
POWER WINDOW MAIN SWITCH		DOOR GARNISH	S1-56
ASSEMBLY	S1-17	GLASS STOPPER	S1-57
POWER WINDOW SUBSWITCH ..	S1-19	COWL GRILLE	S1-58
DOOR LOCK AND OPENER	S1-20	COWL GRILLE	S1-58
STRUCTURAL VIEW	S1-20	OUTSIDE MIRROR	S1-59
FRONT DOOR LOCK AND		OUTSIDE MIRROR	S1-59
OPENER	S1-21	POWER OUTSIDE MIRROR	S1-61
REAR DOOR LOCK AND		POWER OUTSIDE MIRROR	
OPENER	S1-24	SWITCH	S1-61
DOOR LOCK ACTUATOR	S1-25	REARVIEW MIRROR	S1-62
DOOR KEY CYLINDER SWITCH ..	S1-25	PREPARATION	S1-62
DOOR LOCK SWITCH	S1-26	REARVIEW MIRROR	S1-62
DOOR LOCK TIMER UNIT	S1-27	REAR WINDOW DEFROSTER	S1-64
TRUNK LID	S1-29	STRUCTURAL VIEW	S1-64
TRUNK LID	S1-29	REAR WINDOW DEFROSTER	
TRUNK LID LOCK AND OPENER ..	S1-31	SWITCH	S1-65
TRUNK LID LOCK AND OPENER ..	S1-31	FILAMENT	S1-66
FUEL-FILLER LID	S1-33	WINDOW GLASS	S1-67
FUEL-FILLER LID	S1-33	PREPARATION	S1-67
FUEL-FILLER LID LOCK AND		WINDSHIELD	S1-67
OPENER	S1-34	REAR WINDOW GLASS	S1-71
FUEL-FILLER LID LOCK AND		SLIDING SUNROOF	S1-75
OPENER	S1-34	SLIDING SUNROOF	S1-75
BUMPER	S1-35	SUNROOF SWITCH	S1-81
FRONT BUMPER	S1-35	SUNROOF RELAY	S1-81
REAR BUMPER	S1-38	SUNROOF MOTOR	S1-81
SPOILER	S1-41	DASHBOARD AND CONSOLE	S1-83
REAR SPOILER	S1-41	STRUCTURAL VIEW	S1-83

DASHBOARD	S1- 84	REAR DOOR TRIM	S1-108
GLOVE COMPARTMENT	S1- 87	REAR PACKAGE TRIM	S1-109
GLOVE COMPARTMENT COVER	S1- 88	REAR PACKAGE FRONT SIDE	
REAR CONSOLE	S1- 89	TRIM	S1-110
FRONT CONSOLE	S1- 90	REAR PACKAGE FRONT TRIM ..	S1-110
SIDE PANEL	S1- 92	SEAT SIDE COMPARTMENT	S1-111
SIDE WALL	S1- 93	TRUNK END TRIM	S1-112
LOWER PANEL	S1- 94	TRUNK SIDE TRIM	S1-113
COLUMN COVER	S1- 95	TRUNK LID TRIM	S1-114
METER HOOD	S1- 96	FLOOR COVERING	S1-115
CENTER LOWER PANEL	S1- 97	CABIN CARPET	S1-115
UPPER COMPARTMENT	S1- 98	HEADLINER	S1-116
TRIM	S1-100	HEADLINER	S1-116
A-PILLAR TRIM	S1-100	SEAT BELT	S1-117
B-PILLAR LOWER TRIM	S1-101	FRONT SEAT BELT	S1-117
B-PILLAR UPPER TRIM	S1-102	FRONT BUCKLE	S1-118
C-PILLAR TRIM	S1-103	REAR SEAT BELT	S1-119
FRONT SIDE TRIM	S1-104	SEAT	S1-121
FRONT SCUFF PLATE	S1-105	FRONT SEAT	S1-121
REAR SCUFF PLATE	S1-106	REAR SEAT	S1-126
FRONT DOOR TRIM	S1-107		

HOOD

HOOD

Removal / Installation

1. Remove in the order shown in the figure. To remove the hood hinge, remove the front fender panel. (Refer to page S1-7.)
2. Install in the reverse order of removal.

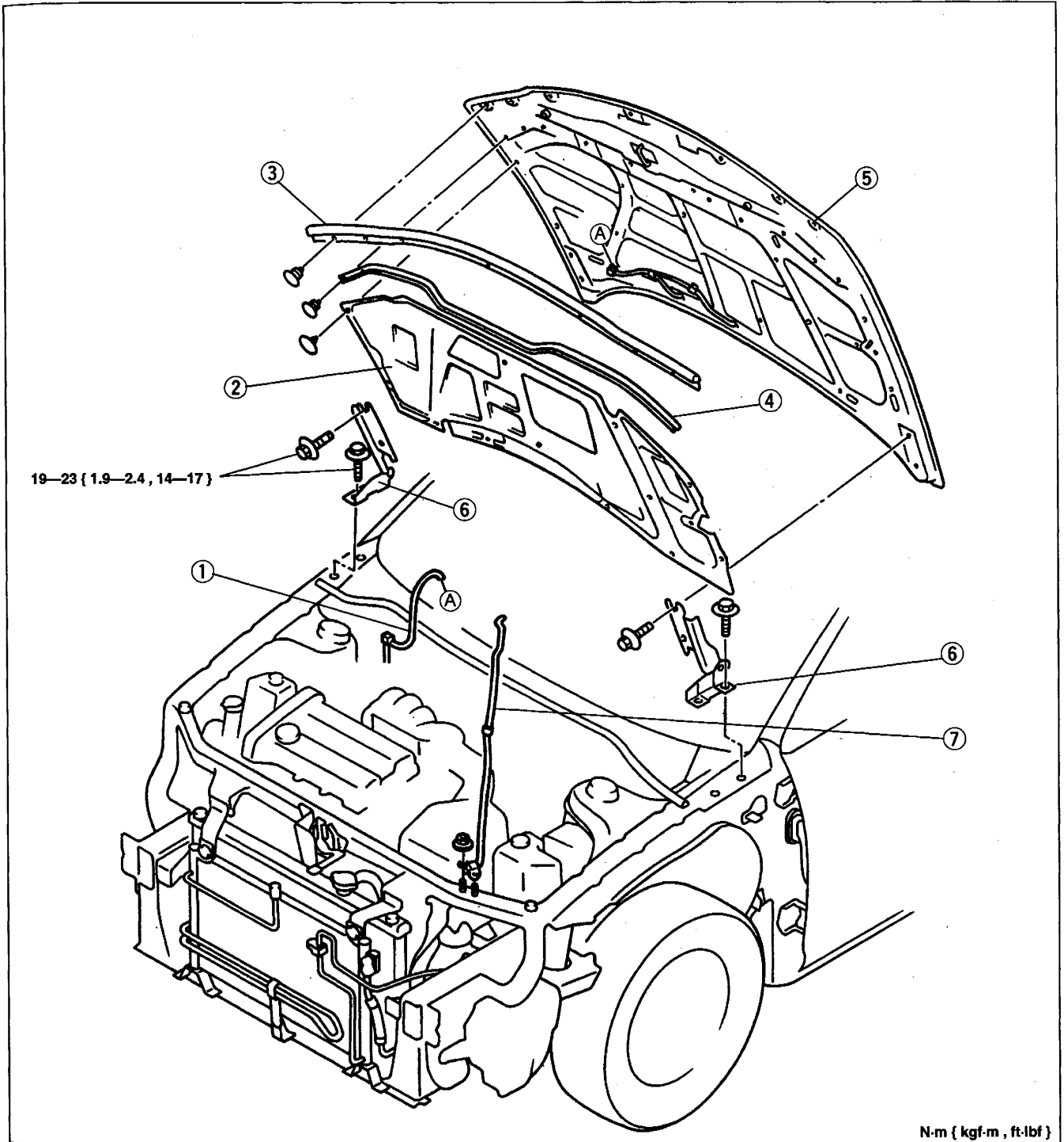

S1

N-m { kgf-m, ft-lbf }

1. Windshield washer pipe
2. Hood insulator
3. Parting seal weatherstrip
4. Surround seal weatherstrip

5. Hood
Adjustment page S1-4
6. Hood hinge
7. Hood stay

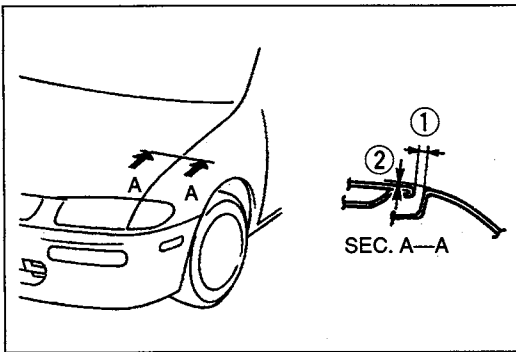
**Adjustment****Hood**

1. Measure the gap and height between the hood and the front fender panel.

Clearance ①: 3.5 ± 1.0 mm { 0.14 ± 0.04 in }

②: 0.5 ± 1.0 mm { 0.02 ± 0.04 in }

2. If not as specified, adjust the gap and height.
3. Adjust the hood lock after the hood has been aligned. (Refer to page S1-5.)

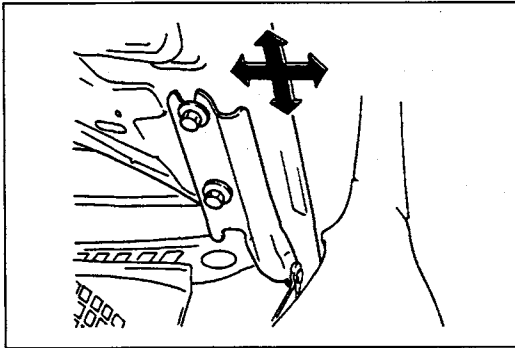
**Gap**

Loosen the hood-to-hinge installation bolts and reposition the hood.

Tightening torque:

$19-23$ N·m { $1.9-2.4$ kgf·m , $14-17$ ft·lbf }

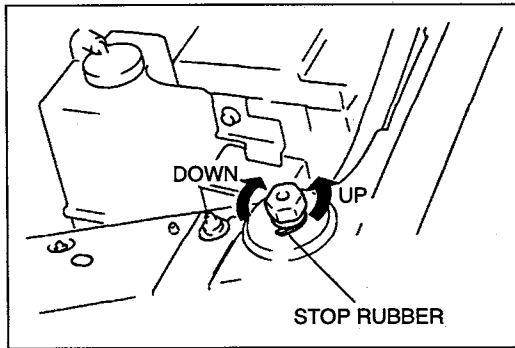
**Height**

Turn the stop rubber to adjust the height of the hood.

HOOD LOCK AND OPENER

HOOD LOCK AND OPENER

Removal / Installation

1. Remove in the order shown in the figure. To remove the hood lock, remove the upper seal board. (Refer to page S1-42.) To remove the release cable, remove the left mud guard. (Refer to page S1-35.)
2. Install in the reverse order of removal.

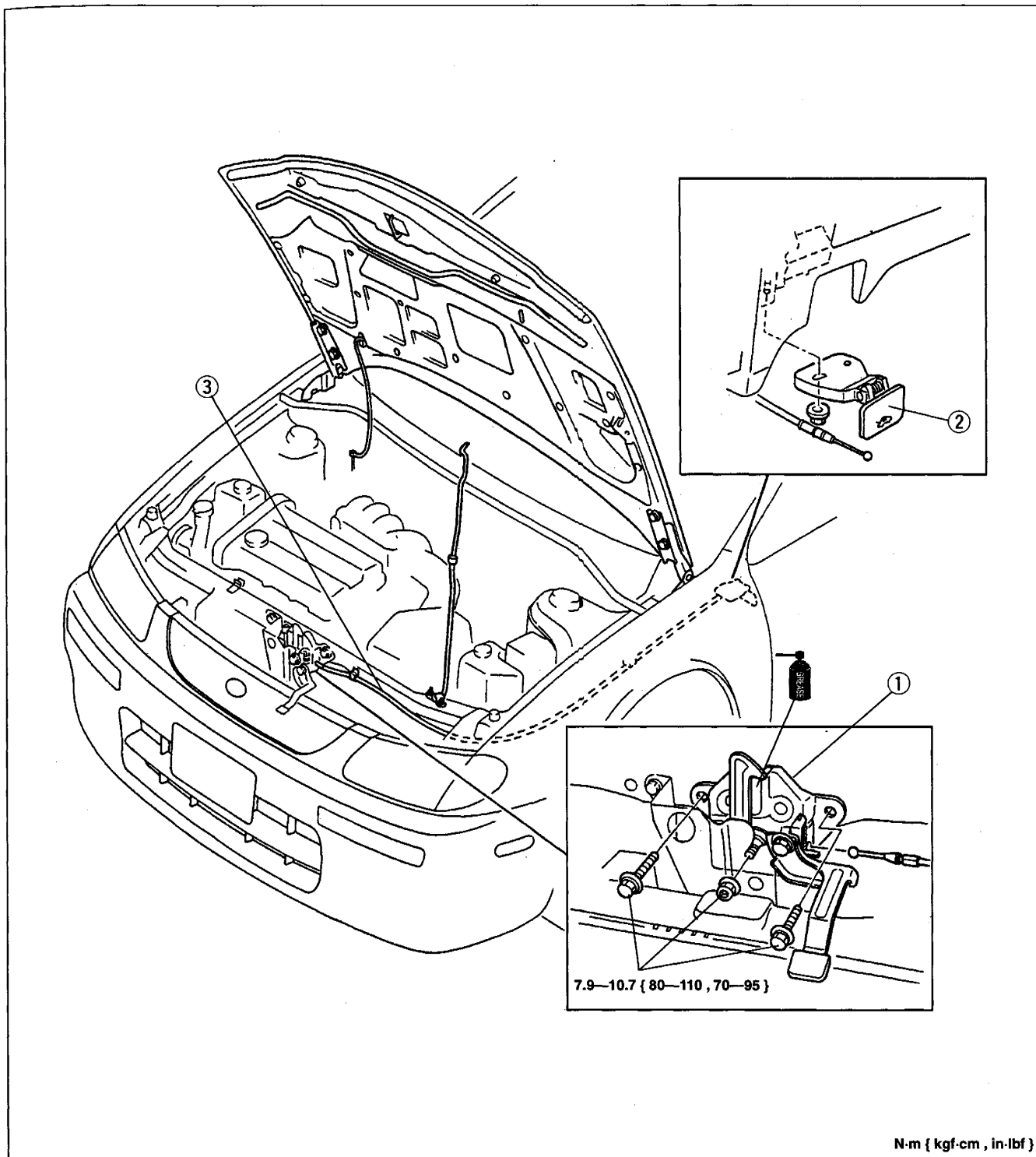

S1

1. Hood lock
Adjustment page S1-6

2. Hood release lever
3. Release cable

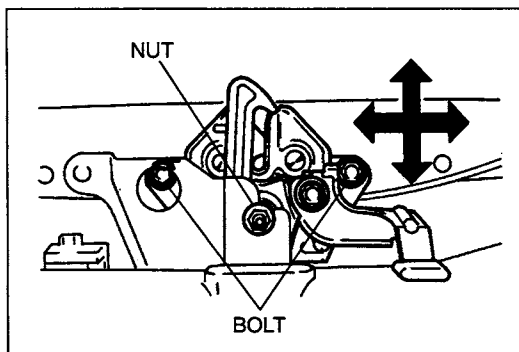
**Adjustment****Hood lock**

1. Verify that the hood is properly aligned.
(Refer to page S1-3.)
2. Loosen the hood lock installation bolts and nut, and align the hood lock with the striker on the hood.

Tightening torque**Bolt:**

7.9—10.7 N·m { 80—110 kgf·cm , 70—95 in·lbf }

Nut:

7.9—10.7 N·m { 80—110 kgf·cm , 70—95 in·lbf }

FRONT FENDER PANEL

FRONT FENDER PANEL

Removal / Installation

1. Disconnect the negative battery cable.
2. Remove the front bumper. (Refer to page S1-35.)
3. Remove as shown in the figure.
4. Install in the reverse order of removal.

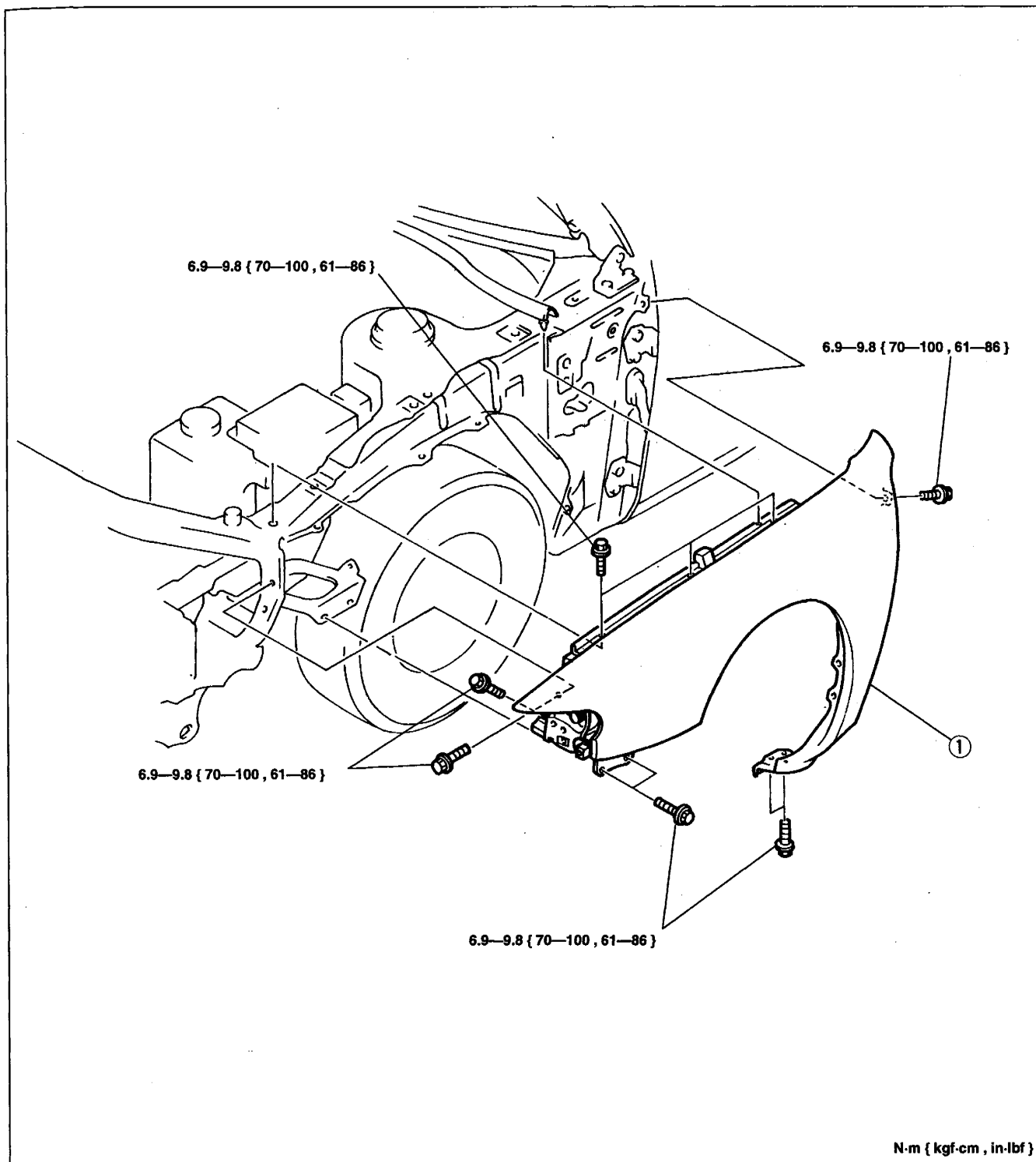

S1

1. Front fender panel

DOOR

FRONT DOOR

Removal / Installation

1. Disconnect the negative battery cable.
2. Remove in the order shown in the figure. To remove the checker, remove the door speaker.
(Refer to section T1.)
3. Install in the reverse order of removal.

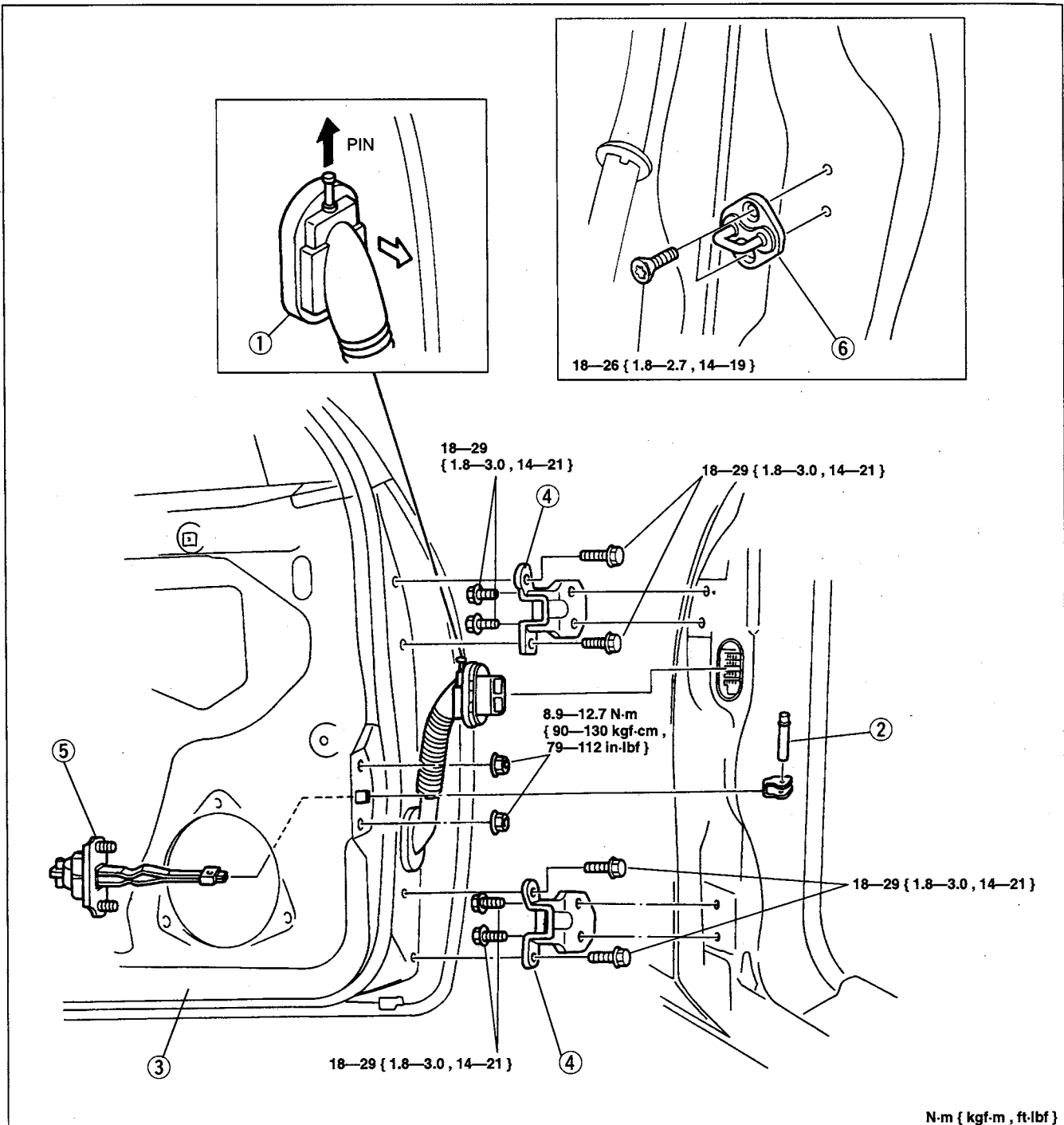

1. Harness connector
2. Checker pin
3. Front door

Adjustment page S1-10

4. Door hinge
5. Checker
6. Door lock striker

Adjustment page S1-10

REAR DOOR
Removal / Installation

1. Disconnect the negative battery cable.

Note

- Remove the door screen carefully so that it may be reused.

2. Remove in the order shown in the figure. To remove the checker, remove the rear door trim (Refer to page S1-108.) and door screen (Refer to page S1-14).
3. Install in the reverse order of removal.

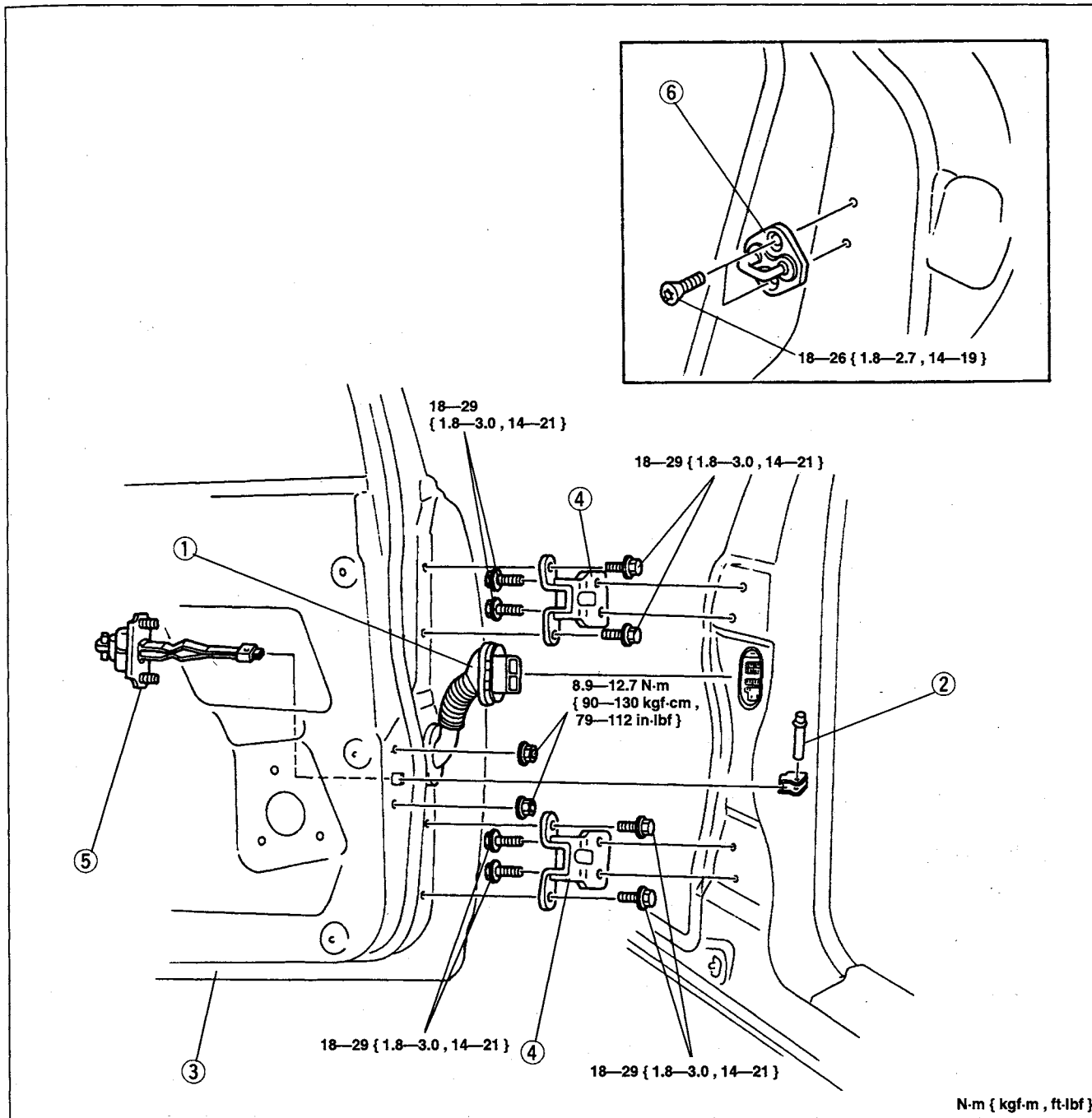

S1

1. Harness connector
2. Checker pin
3. Rear door

4. Door hinge
5. Checker
6. Door lock striker

Adjustment page S1-10

Adjustment page S1-10

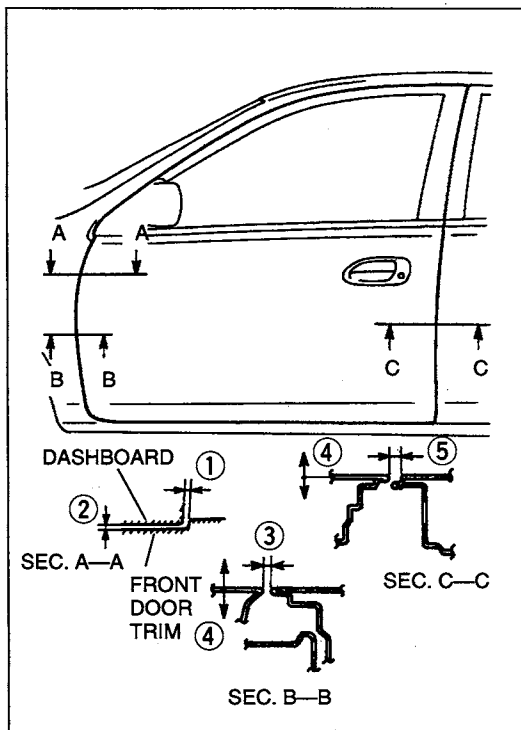
**Adjustment****Front door**

1. Verify that the front door can be closed easily and that there is no looseness or excessive clearance.

Clearance ①: 5.0 ± 3.0 mm { 0.2 ± 0.12 in }

②: $6.0^{+3.0}_{-4.0}$ mm { $0.24^{+0.12}_{-0.16}$ in }

③: 4.0 ± 1.0 mm { 0.16 ± 0.04 in }

④: $0^{+1.0}_{-0.5}$ mm { $0^{+0.04}_{-0.02}$ in }

⑤: 4.2 ± 1.0 mm { 0.17 ± 0.04 in }

2. If not as specified, loosen the door-hinge-to-body mounting bolts and reposition the door.

Tightening torque:

$18-29$ N·m { $1.8-3.0$ kgf·m , $14-21$ ft·lbf }

3. Adjust the door lock striker to the front door after the front door has been aligned. (Refer below.)

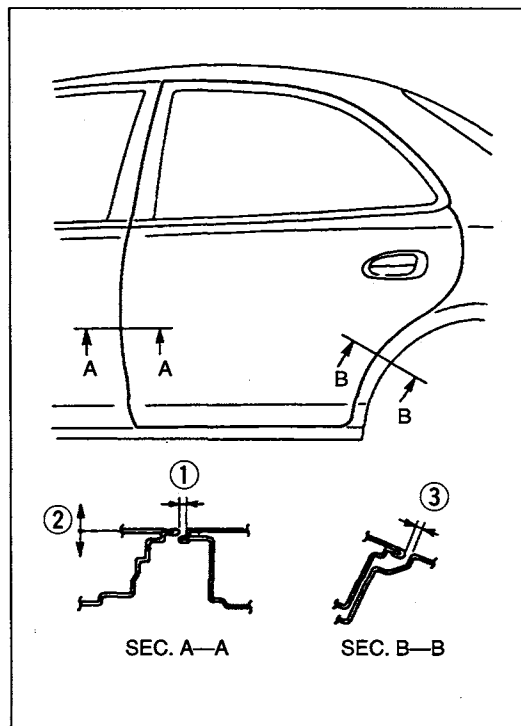
**Rear door**

1. Verify that the rear door can be closed easily and that there is no looseness or excessive clearance.

Clearance ①: 4.2 ± 1.0 mm { 0.17 ± 0.04 in }

②: $0^{+1.0}_{-0.5}$ mm { $0^{+0.04}_{-0.02}$ in }

③: 4.0 ± 1.0 mm { 0.16 ± 0.04 in }

2. If not as specified, loosen the door-hinge-to-body mounting bolts and reposition the door.

Tightening torque:

$18-29$ N·m { $1.8-3.0$ kgf·m , $14-21$ ft·lbf }

3. Adjust the door lock striker to the rear door after the rear door has been aligned. (Refer below.)

Door lock striker

1. Verify that the door can be closed easily and that there is no looseness.
2. If not correct, loosen the striker mounting screws and move the striker horizontally or vertically.

Tightening torque:

$18-26$ N·m { $1.8-2.7$ kgf·m , $14-19$ ft·lbf }

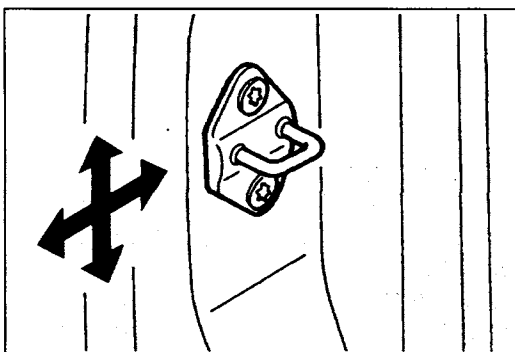

WINDOW REGULATOR, GLASS AND GUIDE

STRUCTURAL VIEW

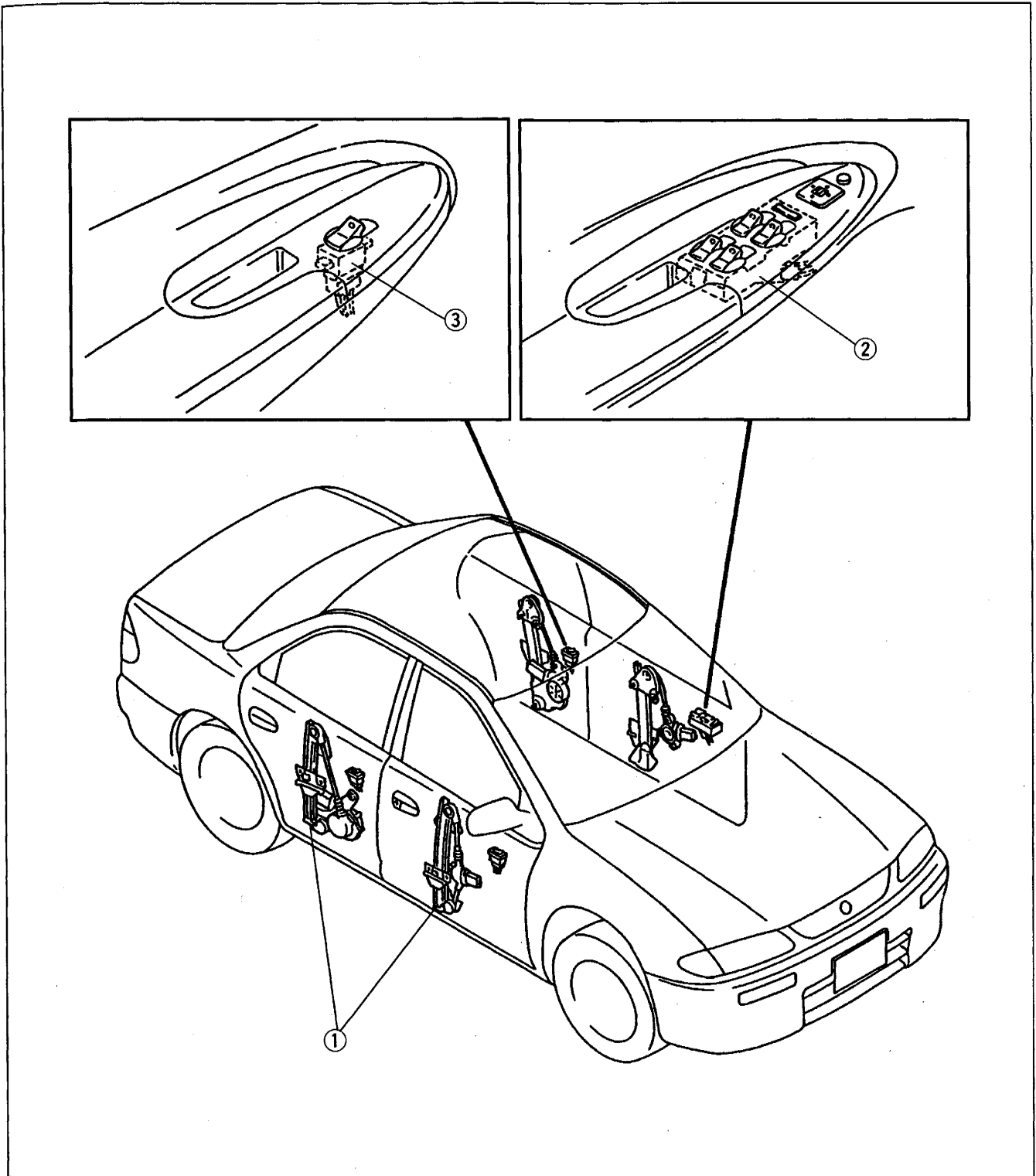

- 1. Power window regulator
 - Removal / Installation (front) .. page S1-12
 - Removal / Installation (rear) .. page S1-14
 - Inspection page S1-16

- 2. Power window main switch assembly
 - Removal / Installation page S1-17
 - Inspection page S1-18
- 3. Power window subswitch
 - Removal / Installation page S1-19
 - Inspection page S1-19

FRONT WINDOW REGULATOR AND GLASS

Removal / Installation

1. Lower the front door glass fully.
2. Disconnect the negative battery cable.

Note

- Remove the door screen carefully so that it may be reused.

3. Remove in the order shown in the figure, referring to **Removal note**.
4. Install in the reverse order of removal, referring to **Installation note**.

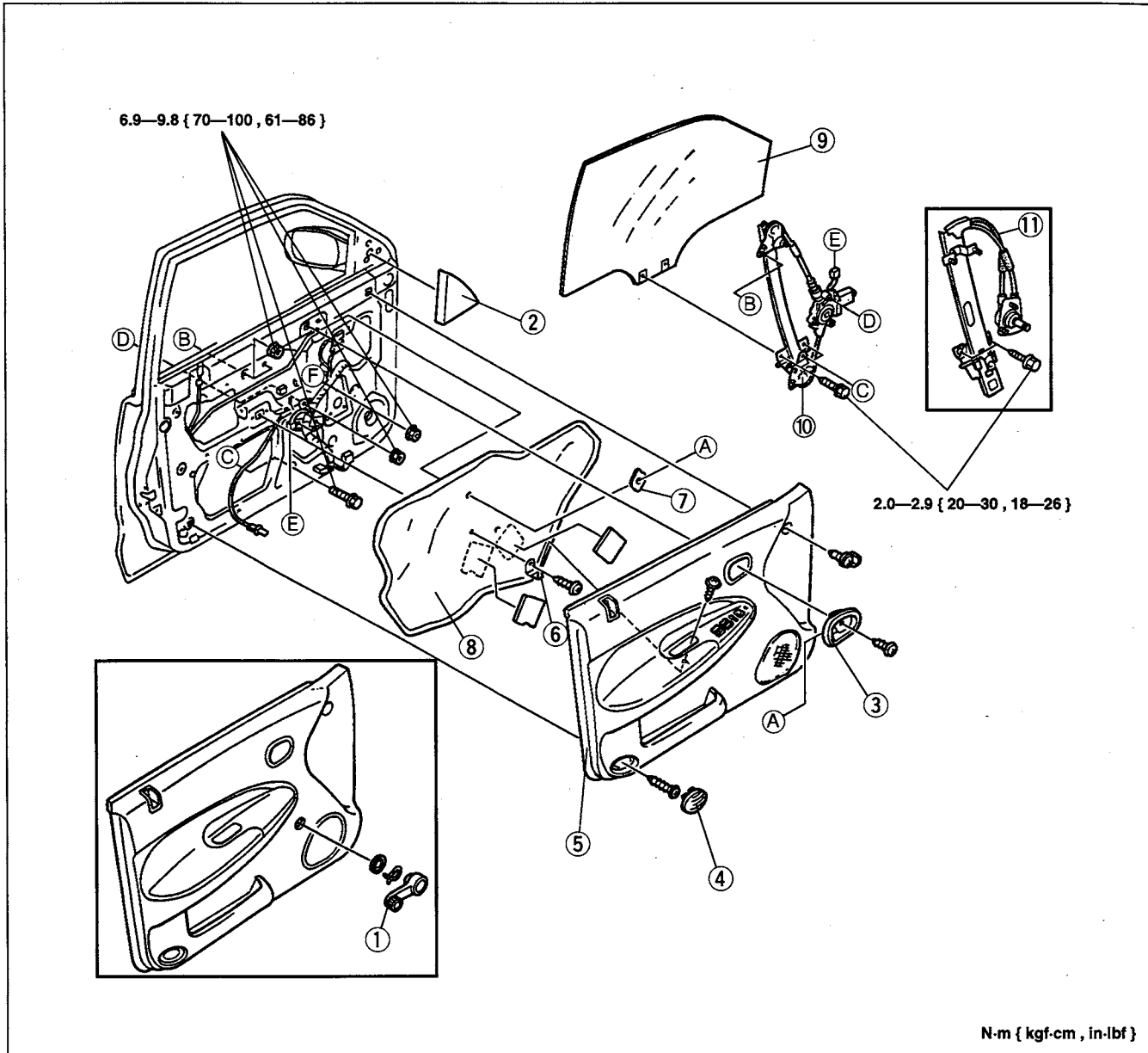

- | | |
|---|--|
| <ol style="list-style-type: none"> 1. Regulator handle
Removal note page S1-13
Installation note page S1-13 2. Inner garnish 3. Inner handle 4. Lens 5. Front door trim
Removal / Installation page S1-107 | <ol style="list-style-type: none"> 6. Bracket 7. Sealing pad 8. Door screen 9. Front door glass 10. Power window regulator 11. Manual window regulator |
|---|--|

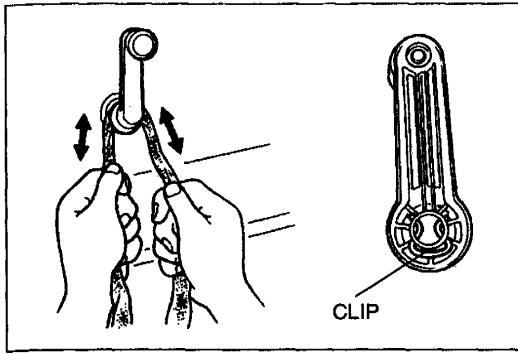

Removal note
Regulator handle

Remove the regulator handle clip by using a rag as shown.

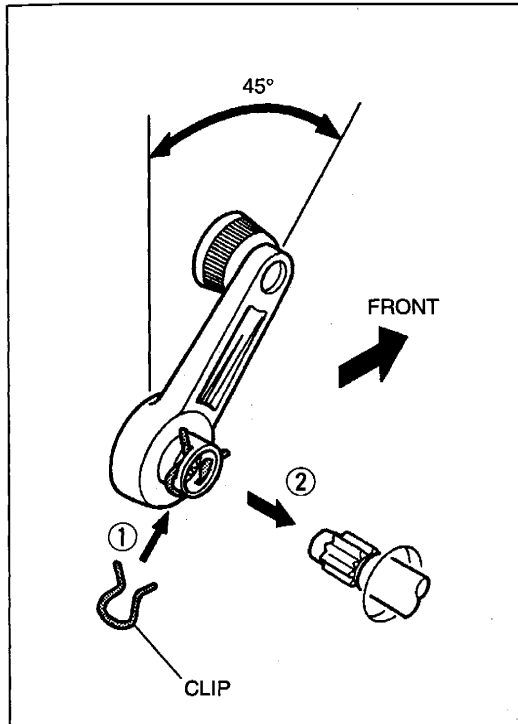

Installation note
Regulator handle

1. Raise the front door glass fully.
2. Install the clip in the regulator handle (1).
3. Push the regulator handle as shown (2).

REAR WINDOW REGULATOR, GLASS AND GUIDE

Removal / Installation

1. Lower the rear door glass fully.
2. Disconnect the negative battery cable.

Note

- Remove the door screen carefully so that it may be reused.

3. Remove in the order shown in the figure, referring to **Removal note**.
4. Install in the reverse order of removal, referring to **Installation note**.

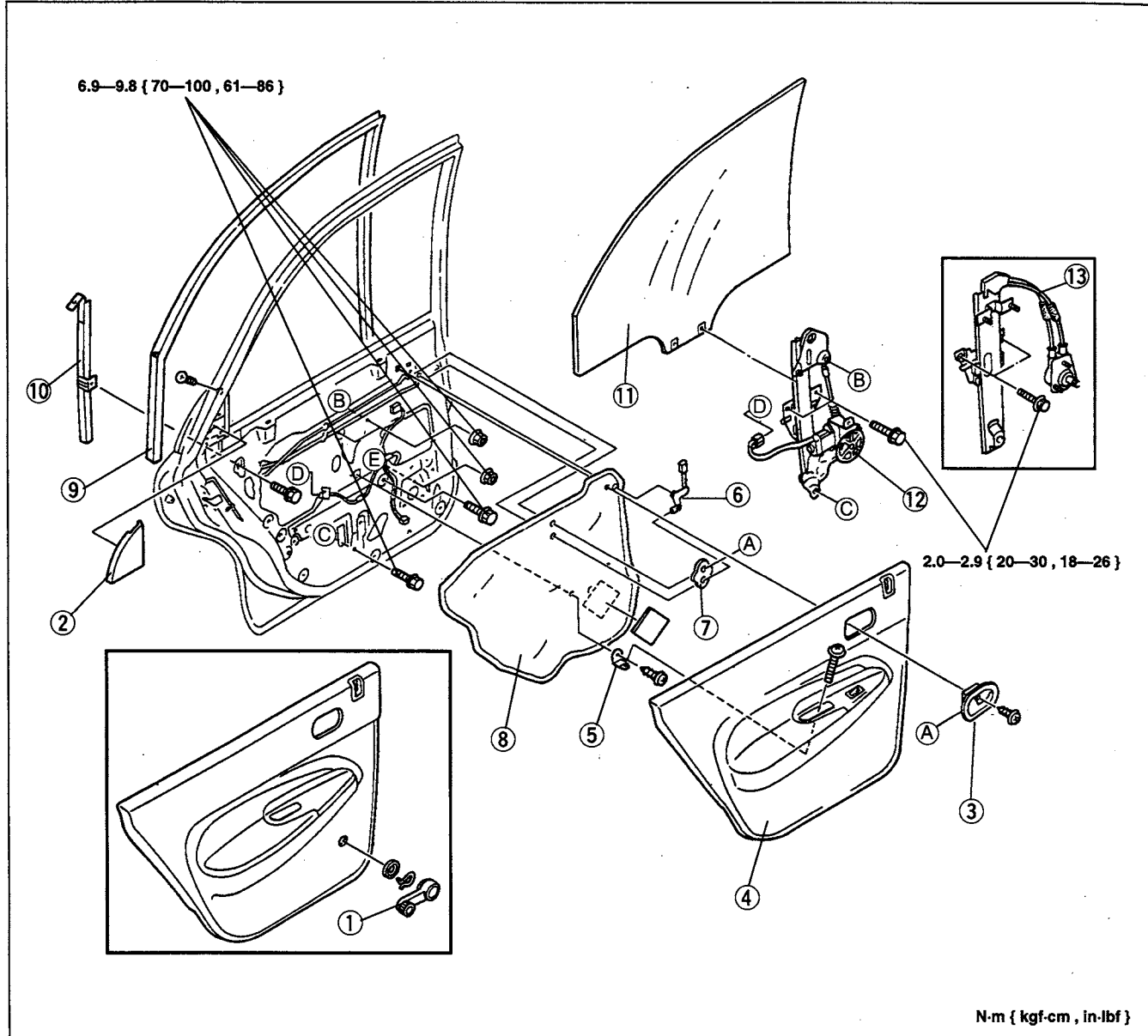

- | | |
|--|------------------------------------|
| 1. Regulator handle | 7. Sealing pad |
| Removal note page S1- 15 | 8. Door screen |
| Installation note page S1- 15 | 9. Glass run channel |
| 2. Inner garnish | Installation note page S1-15 |
| 3. Inner handle | 10. Glass guide |
| 4. Rear door trim | 11. Rear door glass |
| Removal / Installation page S1-108 | Removal note page S1-15 |
| 5. Bracket | 12. Power window regulator |
| 6. Door lock knob and lock bushing | 13. Manual window regulator |

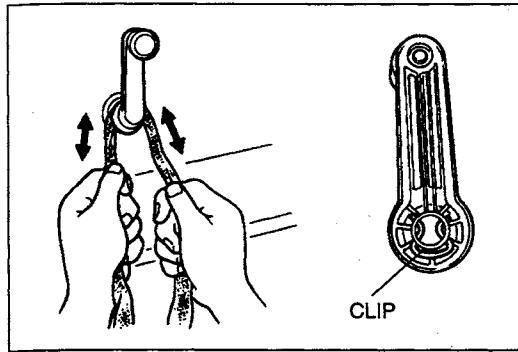

Removal note
Regulator handle

Remove the regulator handle clip by using a rag as shown.

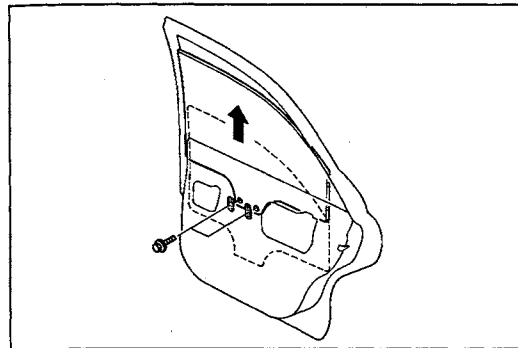

Rear door glass

1. Raise the front edge of the rear door glass about 50 mm { 2.0 in } from the fully lowered position.
2. Remove the glass installation bolts and remove the glass from the inside of the sash.

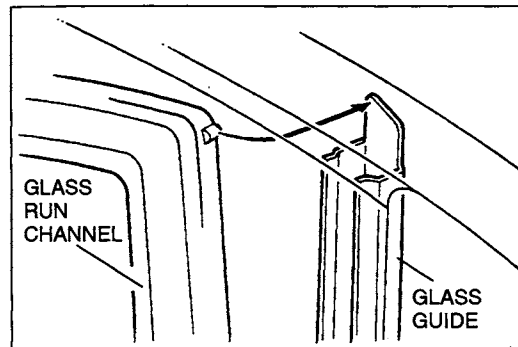

Installation note
Glass run channel

Align the dowel of the glass run channel with the edge of the glass guide and install the glass run channel.

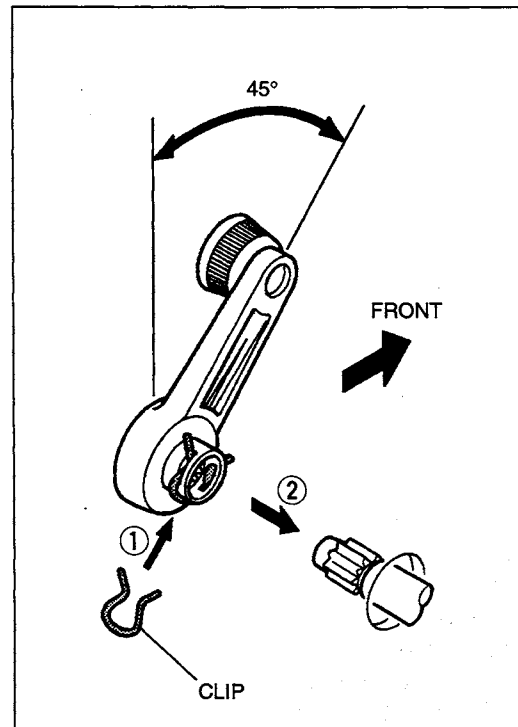

Regulator handle

1. Raise the rear door glass fully.
2. Install the clip in the regulator handle (①).
3. Push the regulator handle as shown (②).

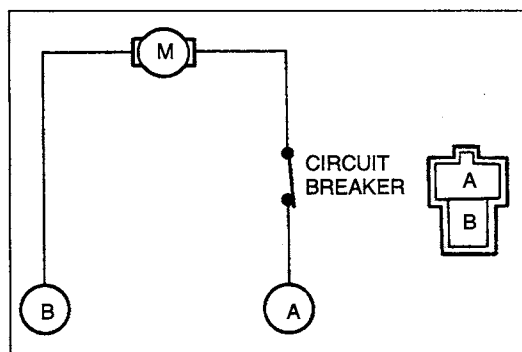

POWER WINDOW REGULATOR

Inspection

1. Remove the power window regulator.
(Refer to pages S1-12, 14.)
2. Apply battery positive voltage to the power window regulator connector terminals and check the operation of the regulator.

B+: Battery positive voltage

Connection		Reulator operation
B+	GND	
A	B	UP
B	A	DOWN

3. If not as specified, replace the power window regulator.

POWER WINDOW MAIN SWITCH ASSEMBLY**Removal / Installation**

1. Disconnect the negative battery cable.
2. Remove the front door trim. (Refer to page S1-107.)
3. Remove as shown in the figure.
4. Install in the reverse order of removal.

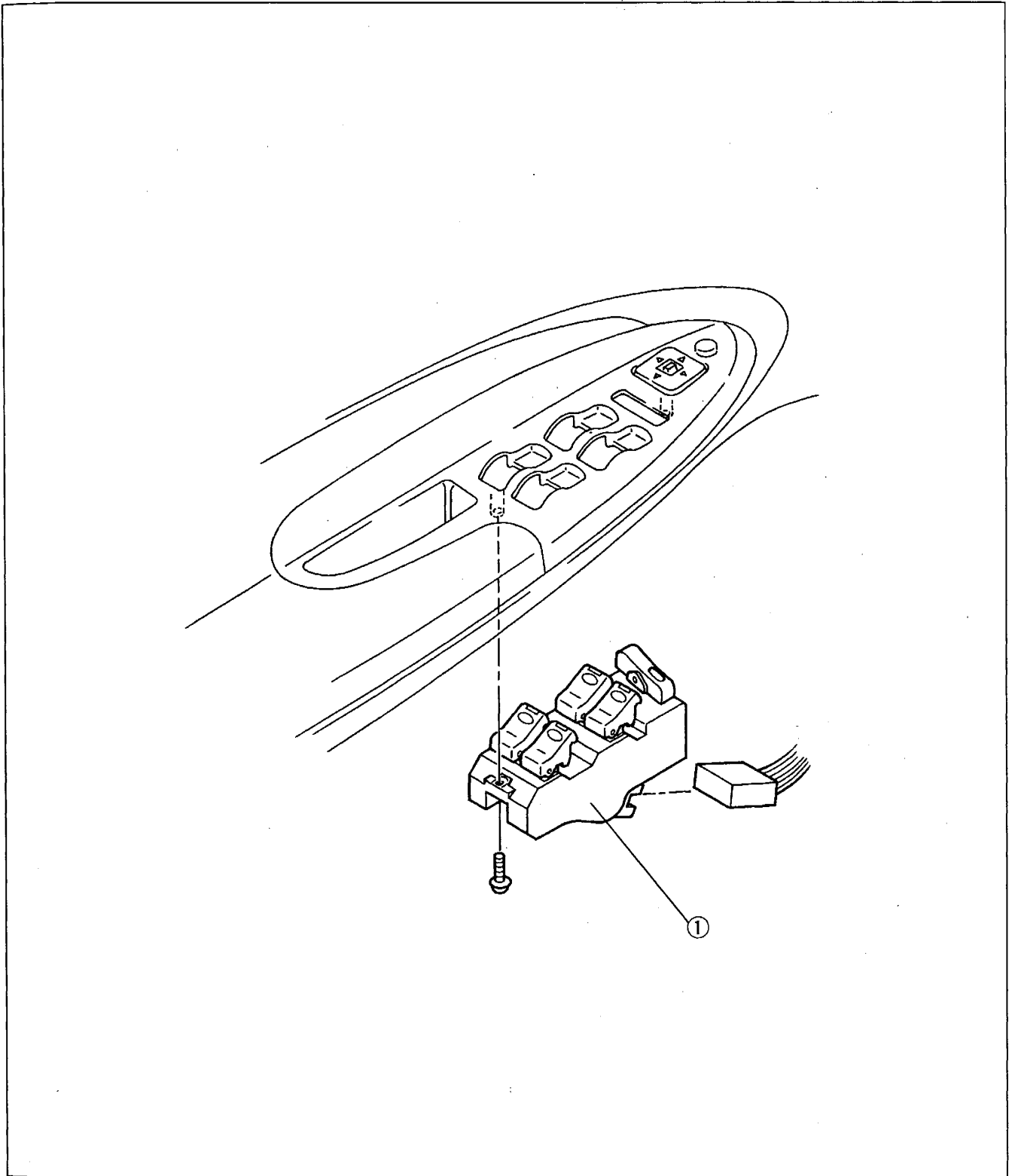

1. Power window main switch assembly
Inspection page S1-18

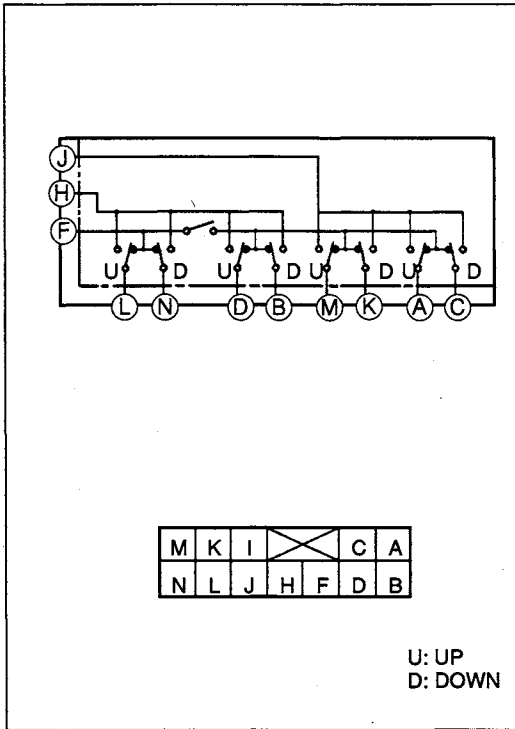

Inspection

1. Remove the power window main switch assembly.
(Refer to page S1-17.)
2. Check for continuity between the terminals of the main switch assembly connector with the main switches in the following positions.
3. If not as specified, replace the power window main switch assembly.

	Switch	Driver				Passenger				Left rear				Right rear			
	Terminal	L	N	H	F	D	B	H	F	M	K	J	F	A	C	J	F
Switch position																	
UP		○	○	○	○	○	○	○	○	○	○	○	○	○	○	○	○
OFF (with power-cut switch at ON)		○	○	○	○	○	○	○	○	○	○	○	○	○	○	○	○
DOWN		○	○	○	○	○	○	○	○	○	○	○	○	○	○	○	○
AUTO DOWN		○	○	○	○												

○—○: Continuity

POWER WINDOW SUBSWITCH

Removal / Installation

1. Disconnect the negative battery cable.
2. Remove the passenger's/rear door trim. (Refer to pages S1-107, 108.)
3. Remove as shown in the figure.
4. Install in the reverse order of removal.

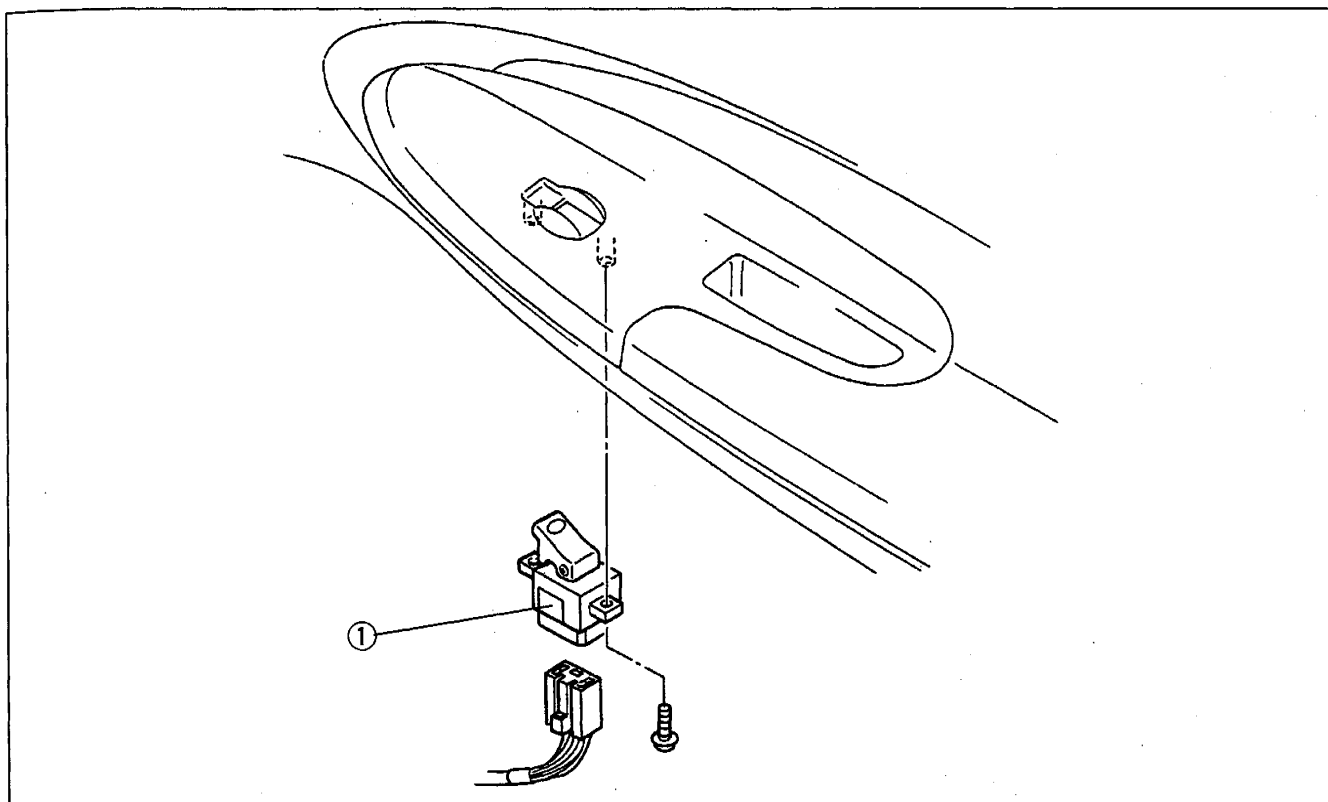

1. Power window subswitch
 Inspection below

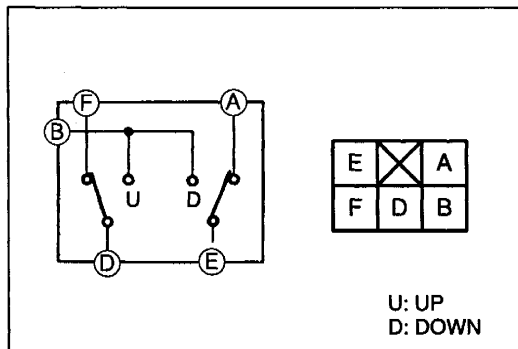

Inspection

1. Remove the power window subswitch. (Refer above.)
2. Check for continuity between the terminals of the sub-switch connector with the subswitch in the following positions.

Terminal	A	B	D	E	F
UP	○	○	○	○	
OFF	○		○	○	○
DOWN		○	○	○	○

○—○: Continuity

3. If not as specified, replace the power window subswitch.

DOOR LOCK AND OPENER

STRUCTURAL VIEW

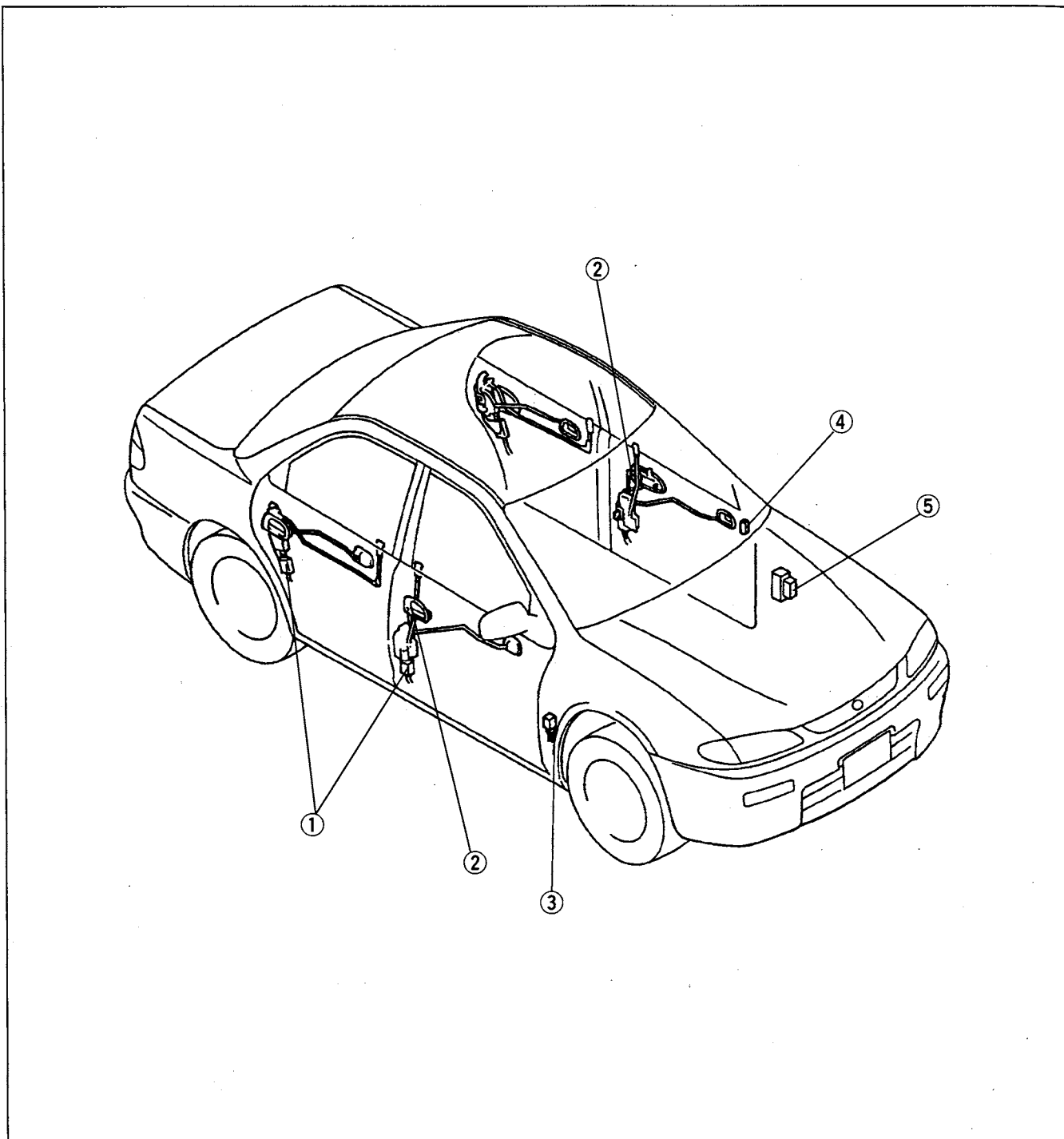

- | | |
|--|--|
| <p>1. Door lock actuator (within door lock)
 Removal / Installation (front) .. page S1-21
 Removal / Installation (rear) .. page S1-24</p> | <p>4. Door lock switch
 Removal / Installation page S1-26
 Inspection page S1-26</p> |
| <p>2. Door key cylinder switch
 Removal / Installation page S1-23
 Inspection page S1-25</p> | <p>5. CPU
 Removal / Installation section T1
 Inspection section T1</p> |
| <p>3. Door lock timer unit
 Removal / Installation page S1-27
 Inspection page S1-28</p> | |

FRONT DOOR LOCK AND OPENER

Removal / Installation

1. Raise the front door glass fully.
2. Disconnect the negative battery cable.

Note

- Remove the door screen carefully so that it may be reused.

3. Remove in the order shown in the figure.
4. Install in the reverse order of removal referring to **Installation note**.

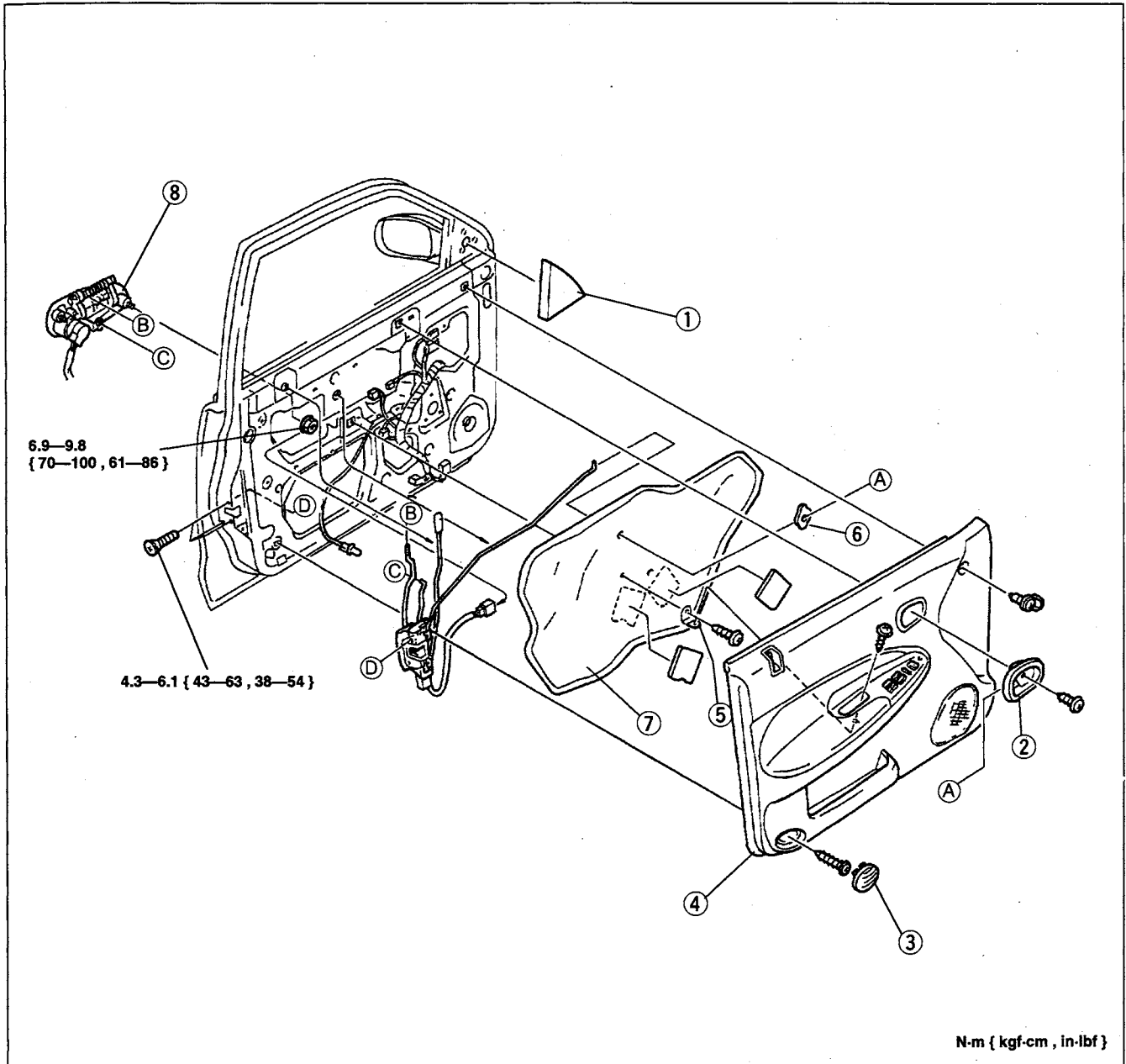

1. Inner garnish
2. Inner handle
3. Lens
4. Front door trim
Removal / Installation page S1-107
5. Bracket

6. Sealing pad
 7. Door screen
 8. Outer handle
- Installation note page S1-22
Disassembly / Assembly page S1-23

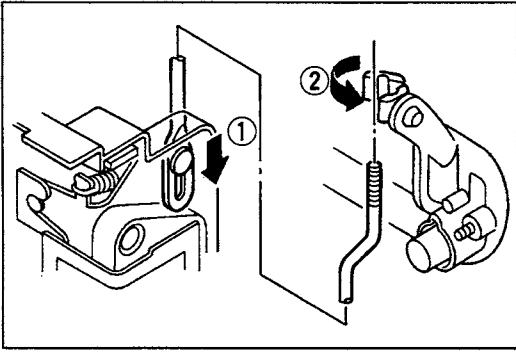

Installation note

Outer handle

1. Lower the push rod fully.
2. Install the push rod into the outer handle joint.

Disassembly / Assembly

1. Disassemble in the order shown in the figure.
2. Assemble in the reverse order of disassembly.

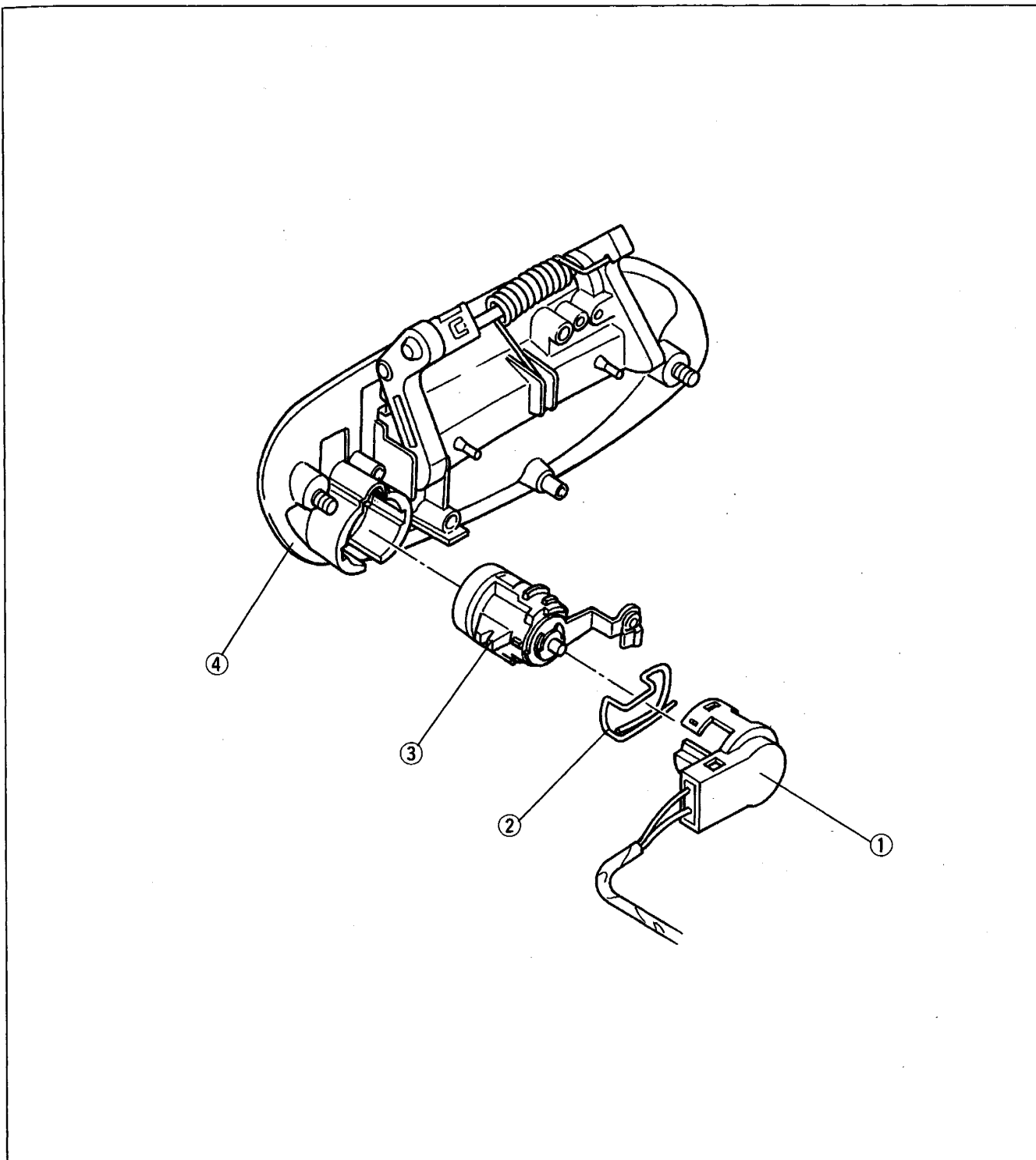

1. Door key cylinder switch

Inspection page S1-25

2. Retainer

3. Door key cylinder

4. Outer handle

REAR DOOR LOCK AND OPENER

Removal / Installation

1. Raise the rear door glass fully.
2. Disconnect the negative battery cable.

Note

- Remove the door screen carefully so that it may be reused.

3. Remove in the order shown in the figure.
4. Install in the reverse order of removal.

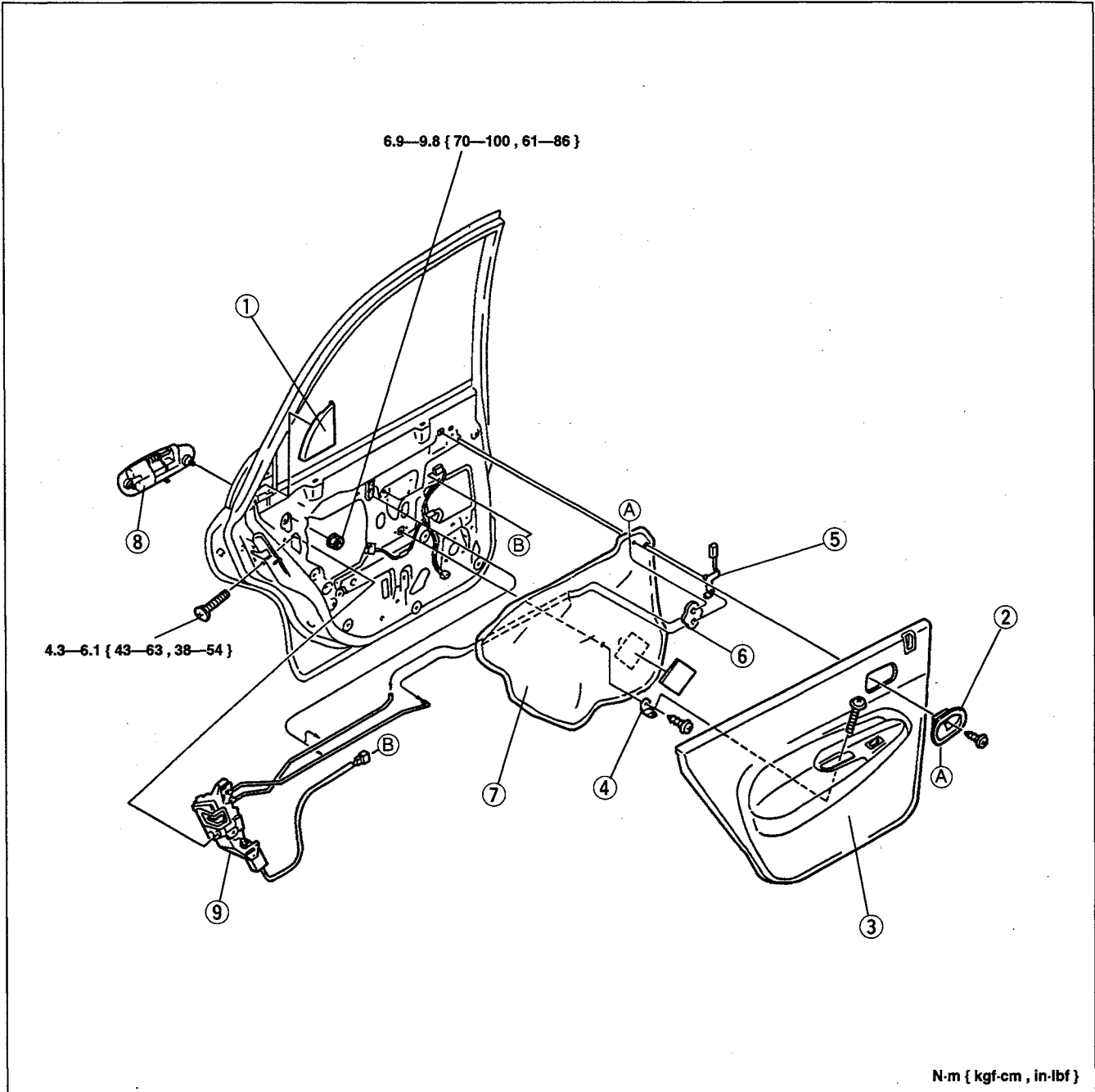

N·m { kgf·cm , in·lbf }

1. Inner garnish
2. Inner handle
3. Rear door trim

Removal / Installation page S1-108

4. Bracket

5. Door lock knob and lock bushing
6. Sealing pad
7. Door screen
8. Outer handle
9. Door lock

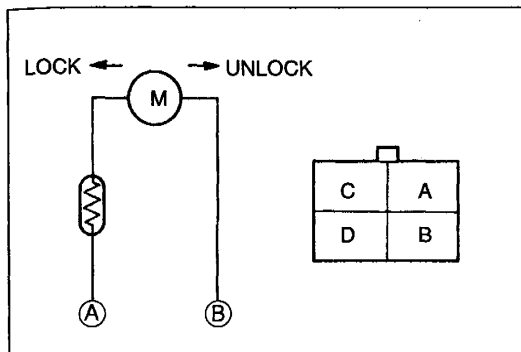

DOOR LOCK ACTUATOR (within door lock)

Inspection

1. Remove the door lock. (Refer to pages S1-21, 23.)
2. Apply battery positive voltage to the connector terminals and check the operation of the actuator.

B+: Battery positive voltage

Connection		Actuator operation
B+	GND	
B	A	Lock
A	B	Unlock

3. If not as specified, replace the door lock.

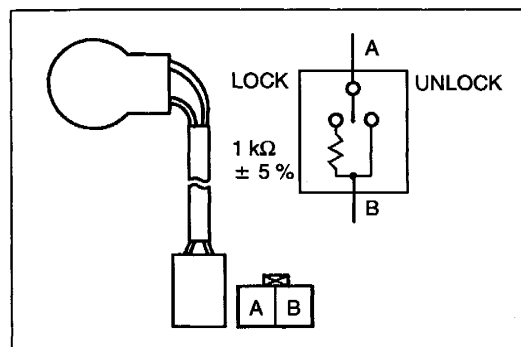

DOOR KEY CYLINDER SWITCH

Inspection

1. Remove the door screen. (Refer to page S1-21.)
2. Disconnect the door key cylinder switch connector.
3. Check for continuity between the terminals of the connector with the key cylinder in the following positions.

Cylinder position \ Terminal	A	B
	Lock	○ — $1\text{ k}\Omega$ — ○
Unlock	○ — ○	○ — ○

○—○: Continuity

4. If not as specified, replace the door key cylinder.

DOOR LOCK SWITCH

Removal / Installation

1. Disconnect the negative battery cable.
2. Remove the front door trim. (Refer to page S1-107.)
3. Remove as shown in the figure.
4. Install in the reverse order of removal.

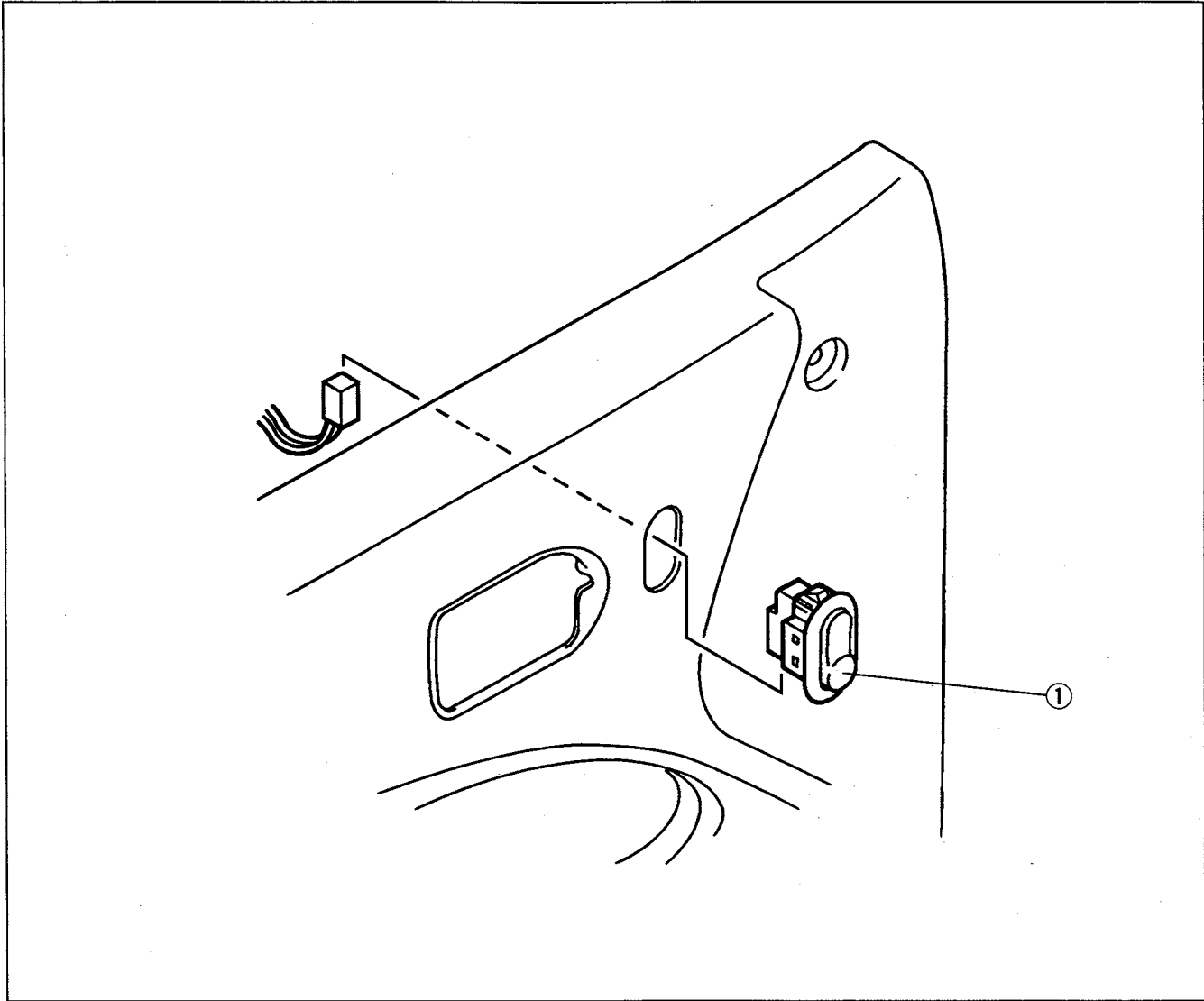

1. Door lock switch
Inspection below

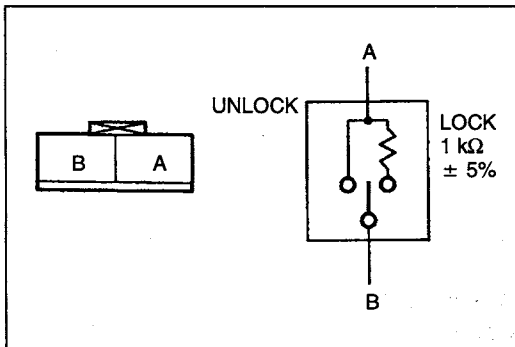

Inspection

1. Remove the door lock switch. (Refer above.)
2. Check for continuity between the terminals of the door lock switch.

Terminal	A	B
Switch position		
Lock	○ ———— ⚡ ———— ○	1 kΩ ± 5 %
Unlock	○ ————	○

○ — ○: Continuity

3. If not as specified, replace the door lock switch.

DOOR LOCK TIMER UNIT

Removal / Installation

1. Disconnect the negative battery cable.
2. Remove the right front side trim. (Refer to page S1-104.)
3. Remove in the order shown in the figure.
4. Install in the reverse order of removal.

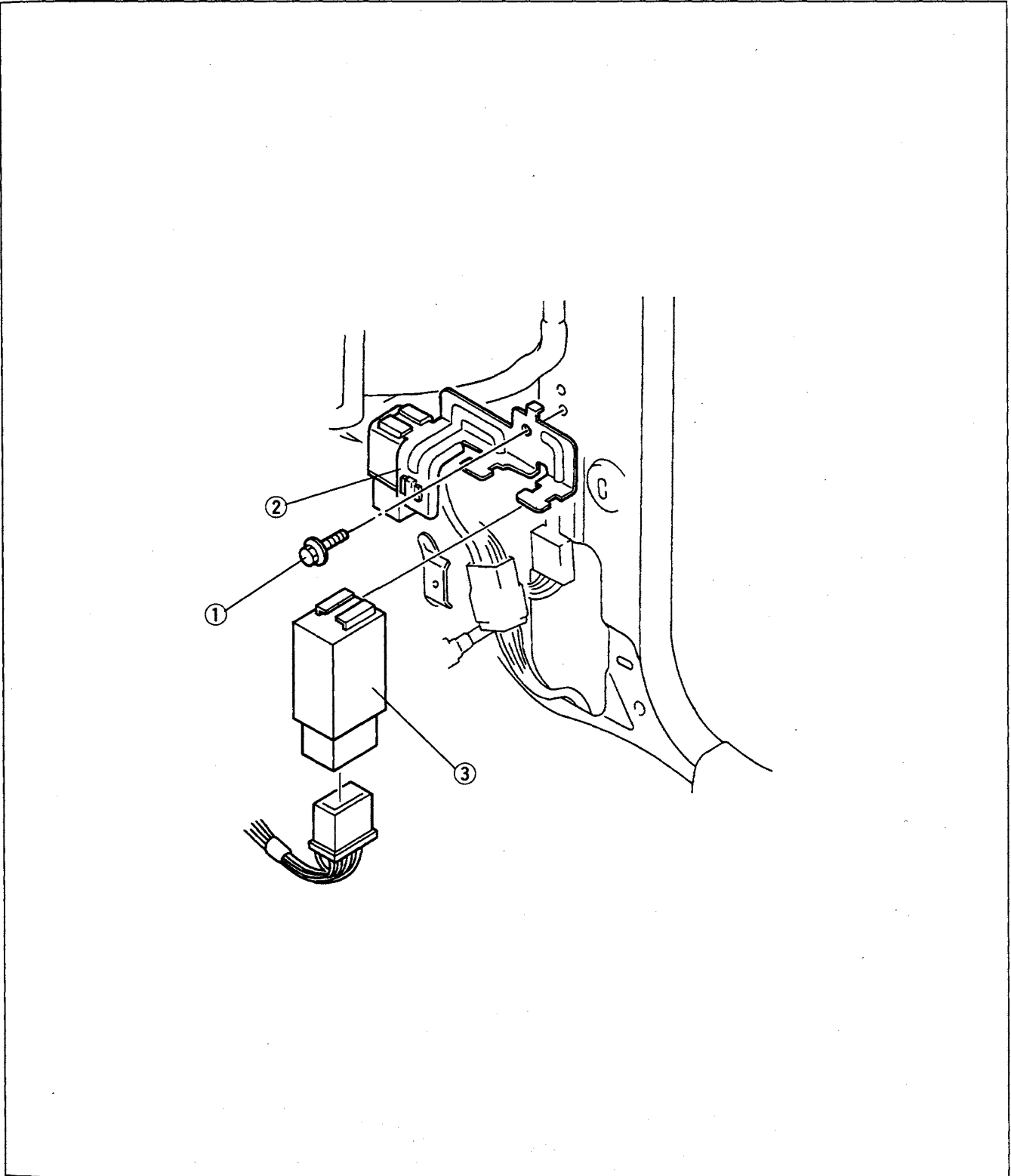

1. Bolt
2. Bracket

3. Door lock timer unit
Inspection page S1-28

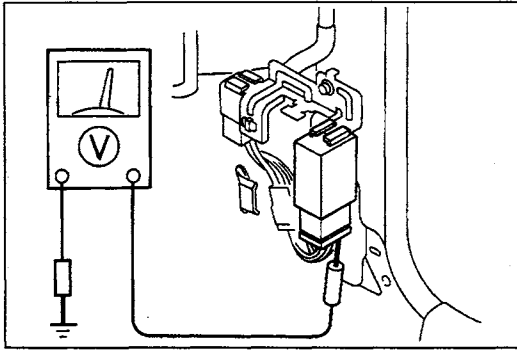

Inspection

1. Remove the right front side trim. (Refer to page S1-104.)
2. Measure the voltage at the door lock timer unit terminals. If not as specified, inspect the parts listed under "Inspection area" and the related wiring harnesses.
3. If the parts and wiring harnesses are OK but the system still does not work properly, replace the door lock timer unit.

Terminal voltage list

B+: Battery positive voltage

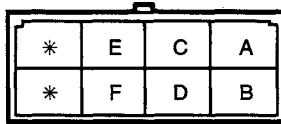

Terminal	Signal	Connection	Test condition	Voltage (V)	Inspection area
A	GND	Body ground	Continuity to ground	Continuity	GND
B	B+	Fuse (DOOR LOCK 30 A)	Constant	B+	Fuse (DOOR LOCK 30 A)
C	Door lock control	CPU	Door lock actuator unlocked	B+→0 →B+	Wiring harness (Door lock timer unit—CPU)
			Other	B+	
D	Door lock control	CPU	Door lock actuator locked	B+→0 →B+	Wiring harness (Door lock timer unit—CPU)
			Other	B+	
E	Actuator lock control	Door lock actuator	Door lock actuator locked	0→B+→0	Wiring harness (Door lock timer unit—Door lock actuator)
			Other	0	
F	Actuator lock control	Door lock actuator	Door lock actuator unlocked	0→B+→0	Wiring harness (Door lock timer unit—Door lock actuator)
			Other	0	

TRUNK LID

TRUNK LID
Removal / Installation

1. Disconnect the negative battery cable.
2. Remove in the order shown in the figure, referring to **Removal note**. To remove the trunk lid hinge, remove the rear package trim. (Refer to page S1-109.)
3. Install in the reverse order of removal.

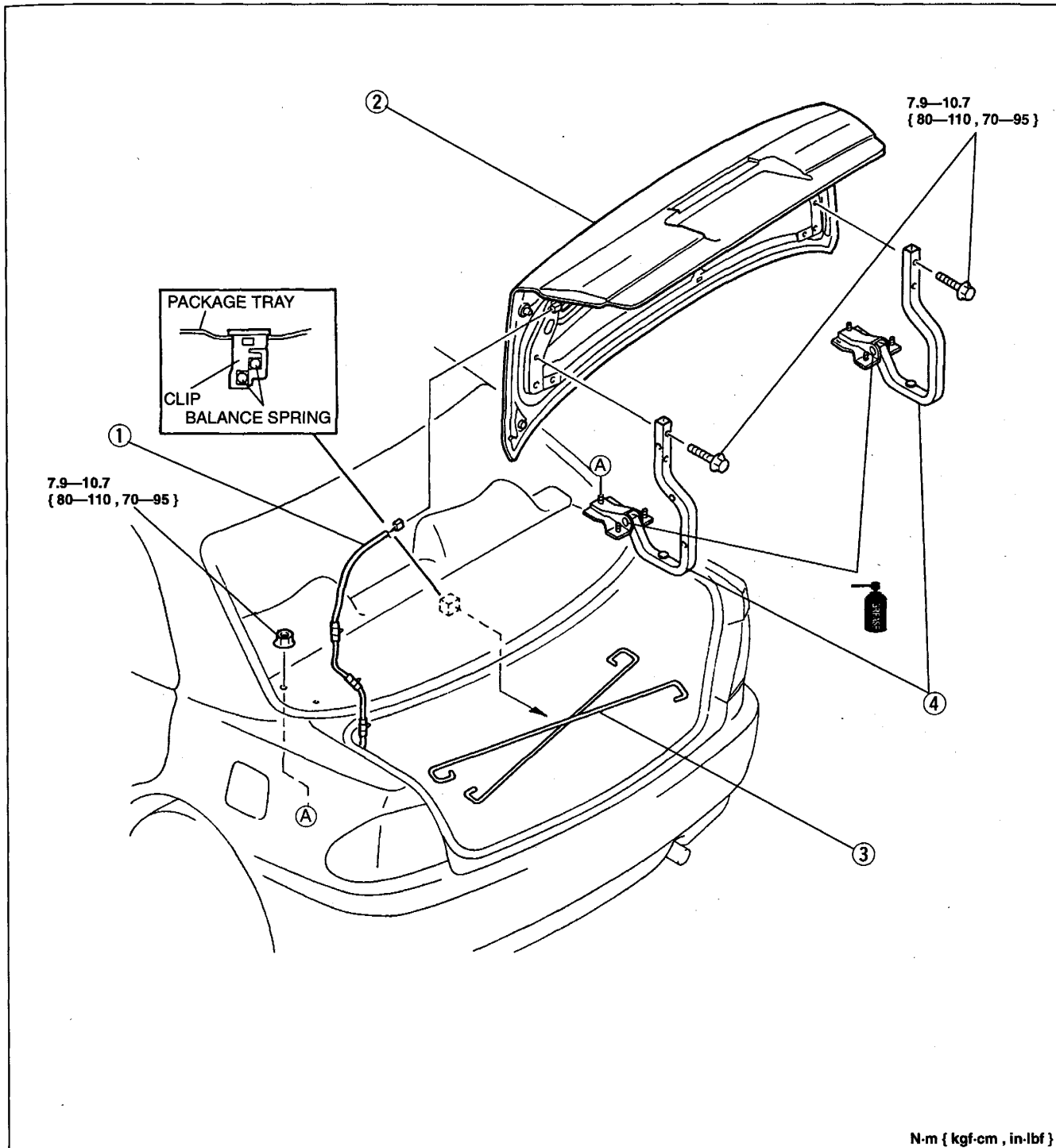

1. Harness connector
2. Trunk lid
Adjustment page S1-30

3. Balance spring
Removal note page S1-30
Adjustment page S1-30
4. Trunk lid hinge

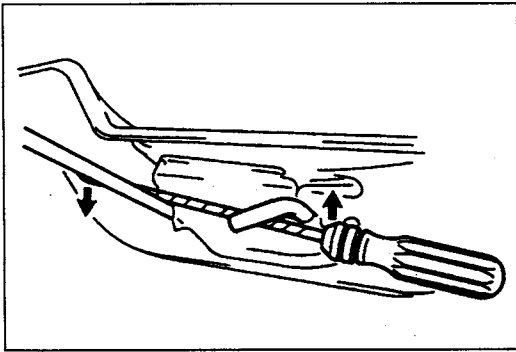

Removal note Balance spring

Warning

- Removing the balance spring without removing the trunk lid can be dangerous. The trunk lid may fall and injure you. Remove the trunk lid before removing the balance spring.

1. Lift the balance spring by using a screwdriver which has been wrapped in tape.
2. Remove the balance spring.

Adjustment Trunk lid

1. Verify that the trunk lid can be closed easily and that there is no looseness or excessive clearance.

Clearance: ① 4.0 ± 1.0 mm { 0.16 ± 0.04 in }
 ② 0.5 ± 1.0 mm { 0.02 ± 0.04 in }

2. If not as specified, loosen the trunk-lid-to-hinge mounting nuts and reposition the trunk lid.

Tightening torque:

$7.9\text{--}10.7$ N·m { $80\text{--}110$ kgf·cm , $70\text{--}95$ in·lbf }

3. Adjust the trunk lid striker after the trunk lid has been aligned. (Refer to page S1-31.)

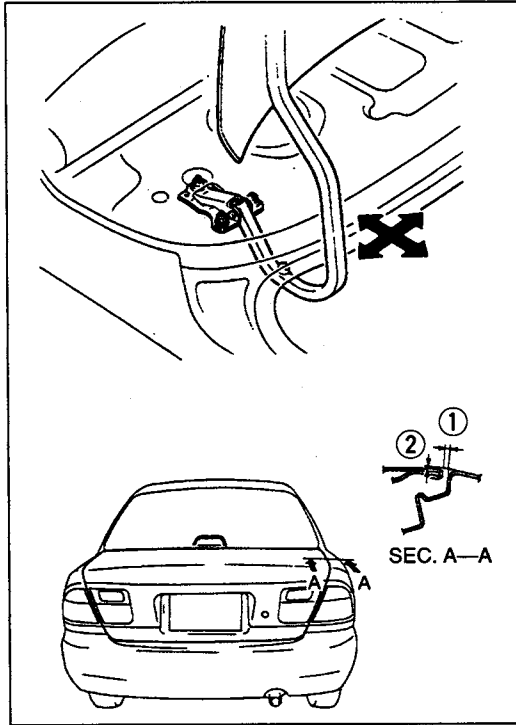

RIGHT SIDE

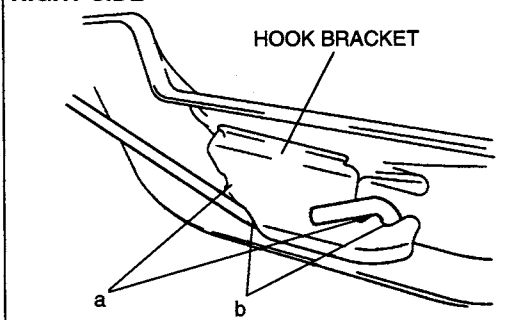

LEFT SIDE

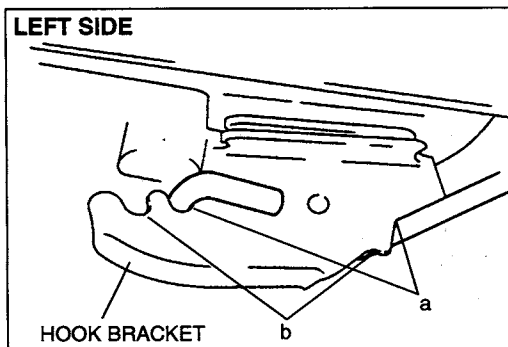

Balance spring

Slide the balance spring to the desired position as described below by using a screwdriver which has been wrapped in tape.

Note

- The trunk lid should raise 70—300 mm { 2.8—11.8 in } when the trunk lid is unlocked.

Tension	Hook bracket	Set position	
		a	b
Standard	Right side		○
	Left side	○	
Increase	Right side		○
	Left side		○
Decrease	Right side	○	
	Left side	○	

○: Position

TRUNK LID LOCK AND OPENER

TRUNK LID LOCK AND OPENER

Removal / Installation

1. Disconnect the negative battery cable.
2. Remove in the order shown in the figure. To remove the trunk key cylinder and trunk lid lock, remove the trunk lid trim. (Refer to page S1-114.) To remove the trunk lid striker, remove the trunk end trim. (Refer to page S1-112.) To remove the trunk lid opener cable, remove the right trunk side trim (Refer to page S1-113.), rear seat back (Refer to pages S1-126, 129.), left front scuff plate (Refer to page S1-105.), and left rear scuff plate (Refer to page S1-106.), and turn over the cabin carpet (Refer to page S1-115.).
3. Install in the reverse order of removal.

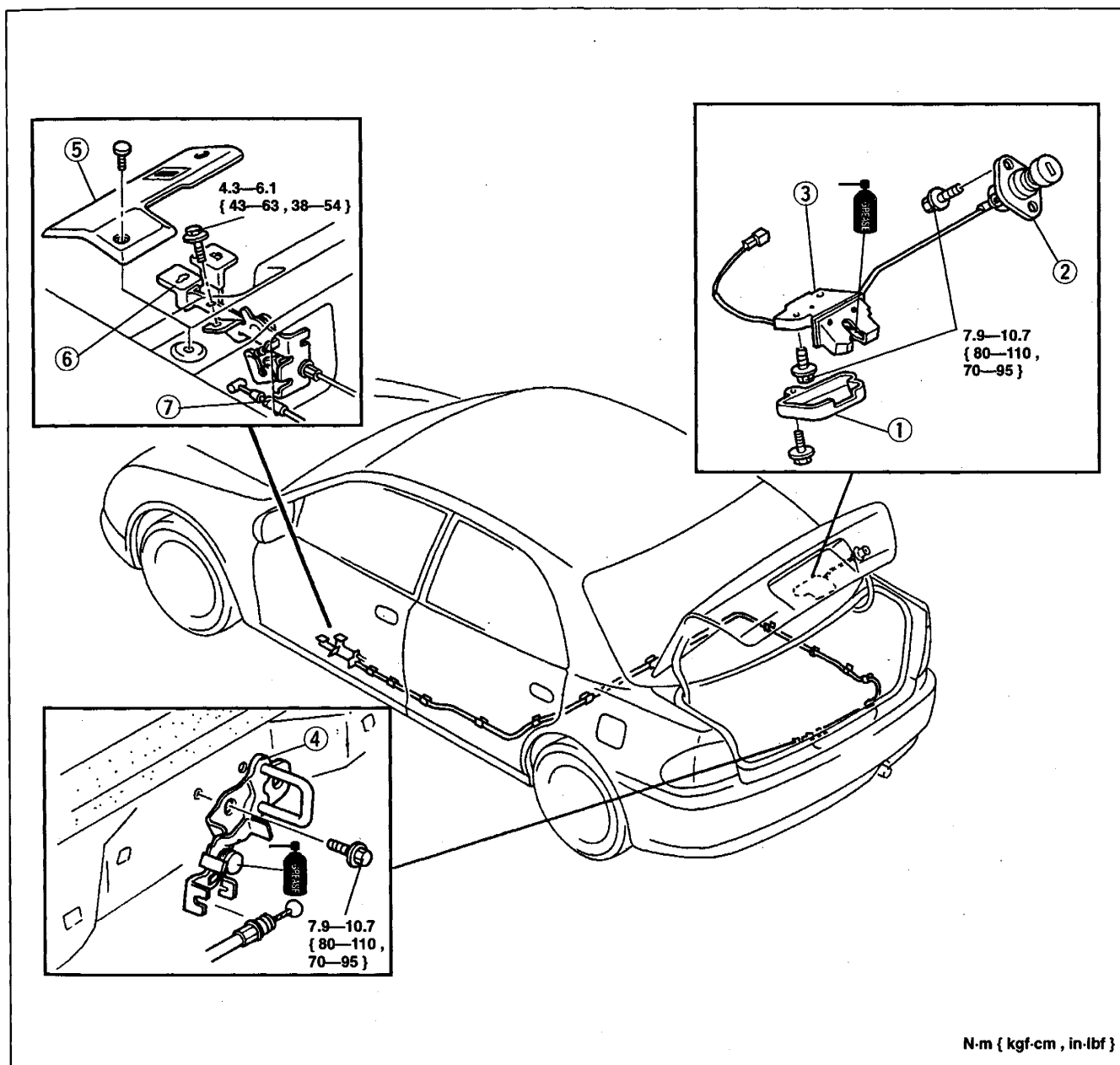

N·m { kgf·cm , in·lbf }

- | | |
|---------------------------------------|---------------------------|
| 1. Protector (without trunk lid trim) | 5. Cover |
| 2. Trunk key cylinder | 6. Trunk lid opener lever |
| 3. Trunk lid lock | 7. Trunk lid opener cable |
| 4. Trunk lid striker | |

Adjustment page S1-32

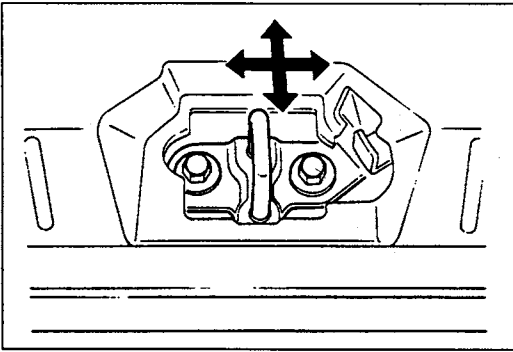
**Adjustment****Trunk lid striker**

1. Verify that the trunk lid is properly aligned.
(Refer to page S1-29.)
2. Loosen the trunk lid striker mounting bolts and align the striker with the trunk lid lock.

Tightening torque:

7.9—10.7 N·m { 80—110 kgf·cm , 70—95 in·lbf }

FUEL-FILLER LID

**FUEL-FILLER LID
Removal / Installation**

1. Remove as shown in the figure.
2. Install in the reverse order of removal.

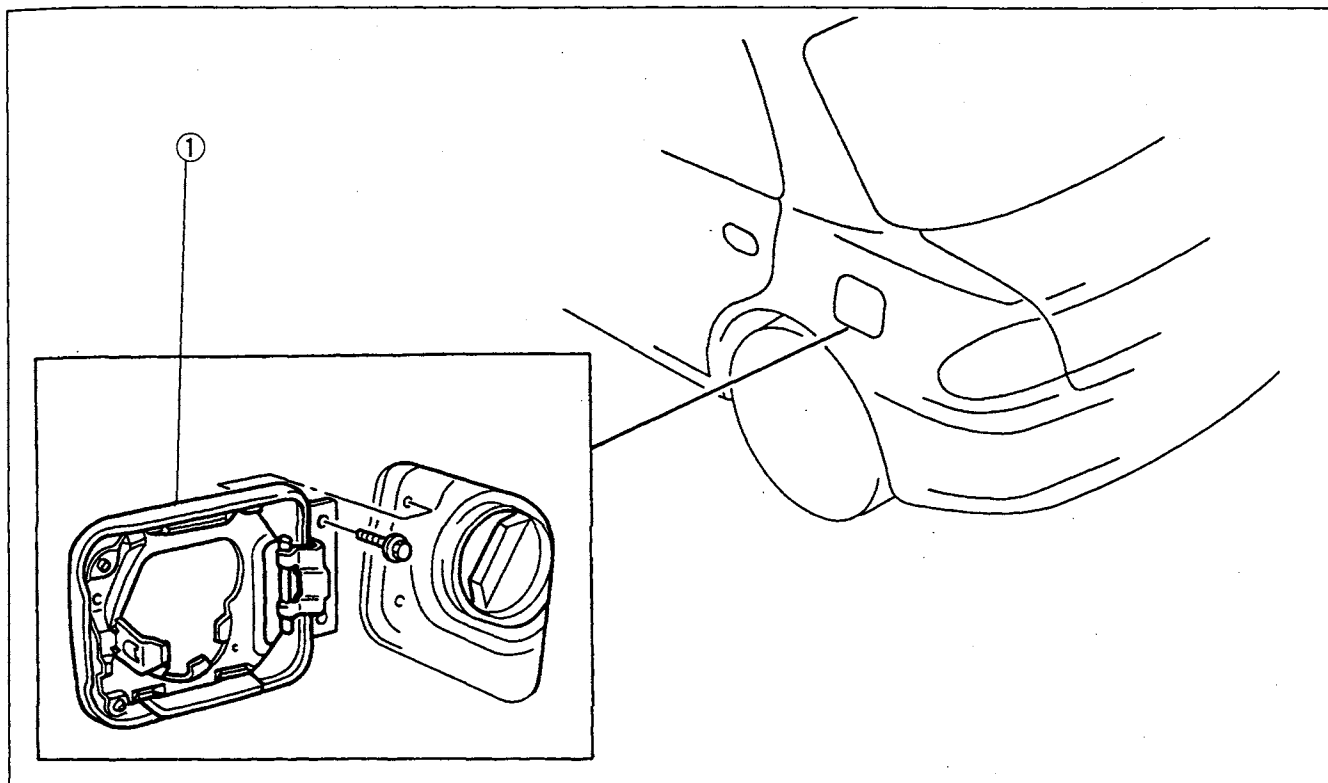

1. Fuel-filler lid
Adjustment below

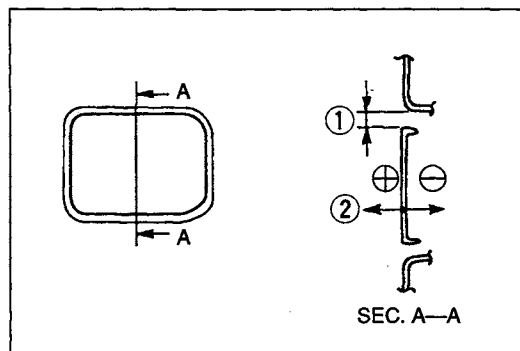

**Adjustment
Fuel-filler lid**

1. Verify that the fuel-filler lid can be closed easily and that there is no looseness or excessive clearance.

Clearance ①: $3.0 \pm 1.0 \text{ mm } \{ 0.12 \pm 0.04 \text{ in } \}$

②: $-0.5^{+1.0}_{-0.5} \text{ mm } \{ 0.02^{+0.04}_{-0.02} \text{ in } \}$

2. If not as specified, loosen the fuel-filler lid mounting bolts and reposition the fuel-filler lid.

FUEL-FILLER LID LOCK AND OPENER

FUEL-FILLER LID LOCK AND OPENER

Removal / Installation

1. Remove the left trunk side trim. (Refer to page S1-113.)
2. Remove in the order shown in the figure. To remove the fuel-filler lid opener cable, remove the rear seat back (Refer to pages S1-126, 129.), left front scuff plate (Refer to page S1-105.), and left rear scuff plate (Refer to page S1-106.), and turn over the cabin carpet (Refer to page S1-115.).
3. Install in the reverse order of removal.

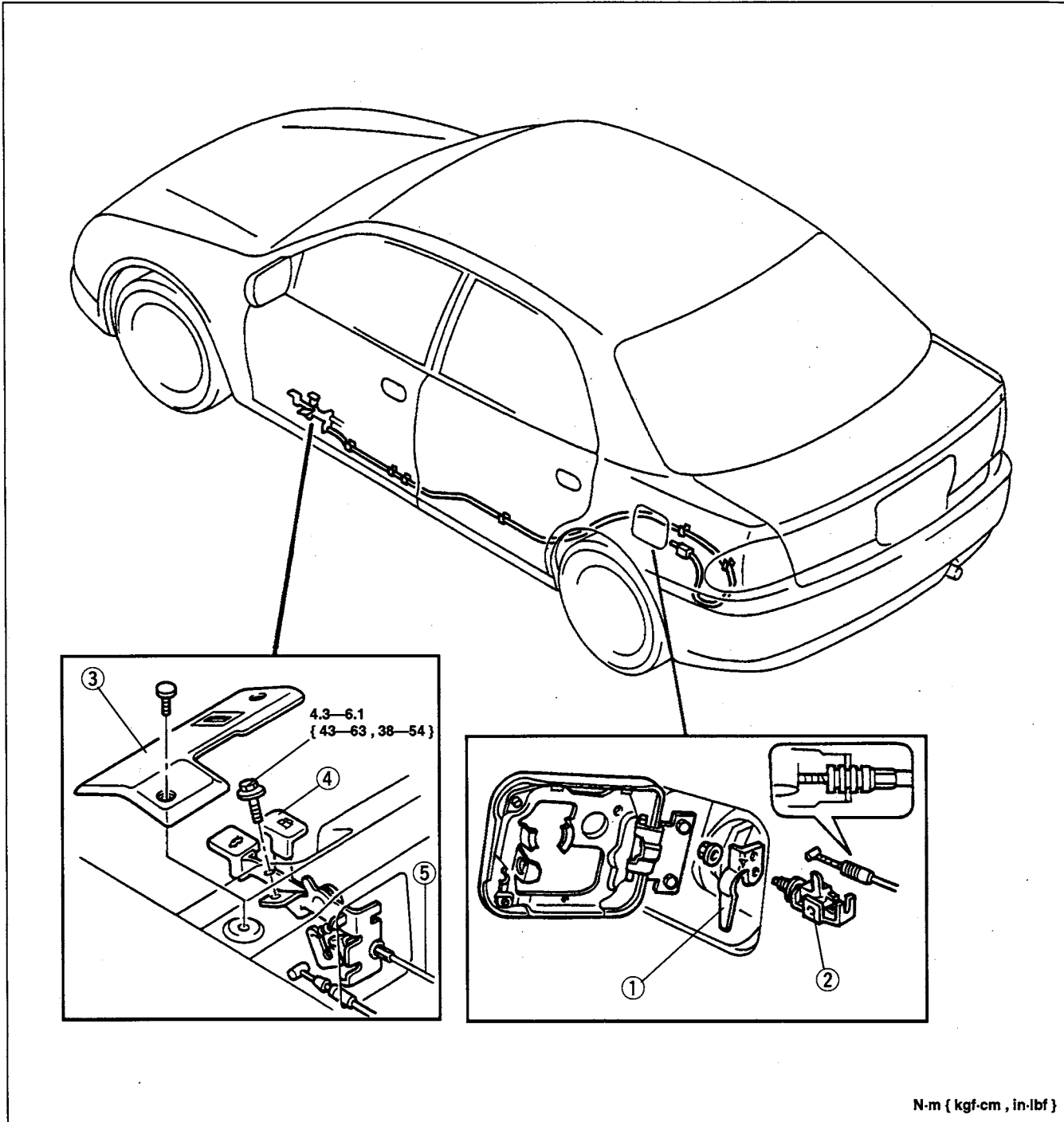

1. Lift spring
2. Fuel-filler lid opener
3. Cover

4. Fuel-filler lid opener lever
5. Fuel-filler lid opener cable

BUMPER

FRONT BUMPER

Removal / Installation

1. Disconnect the negative battery cable.
2. Remove the splash shield. (Refer to section B.)
3. Remove the radiator grille. (Refer to page S1-42.)
4. Remove the headlight. (Refer to section T1.)
5. Remove in the order shown in the figure.
6. Install in the reverse order of removal.

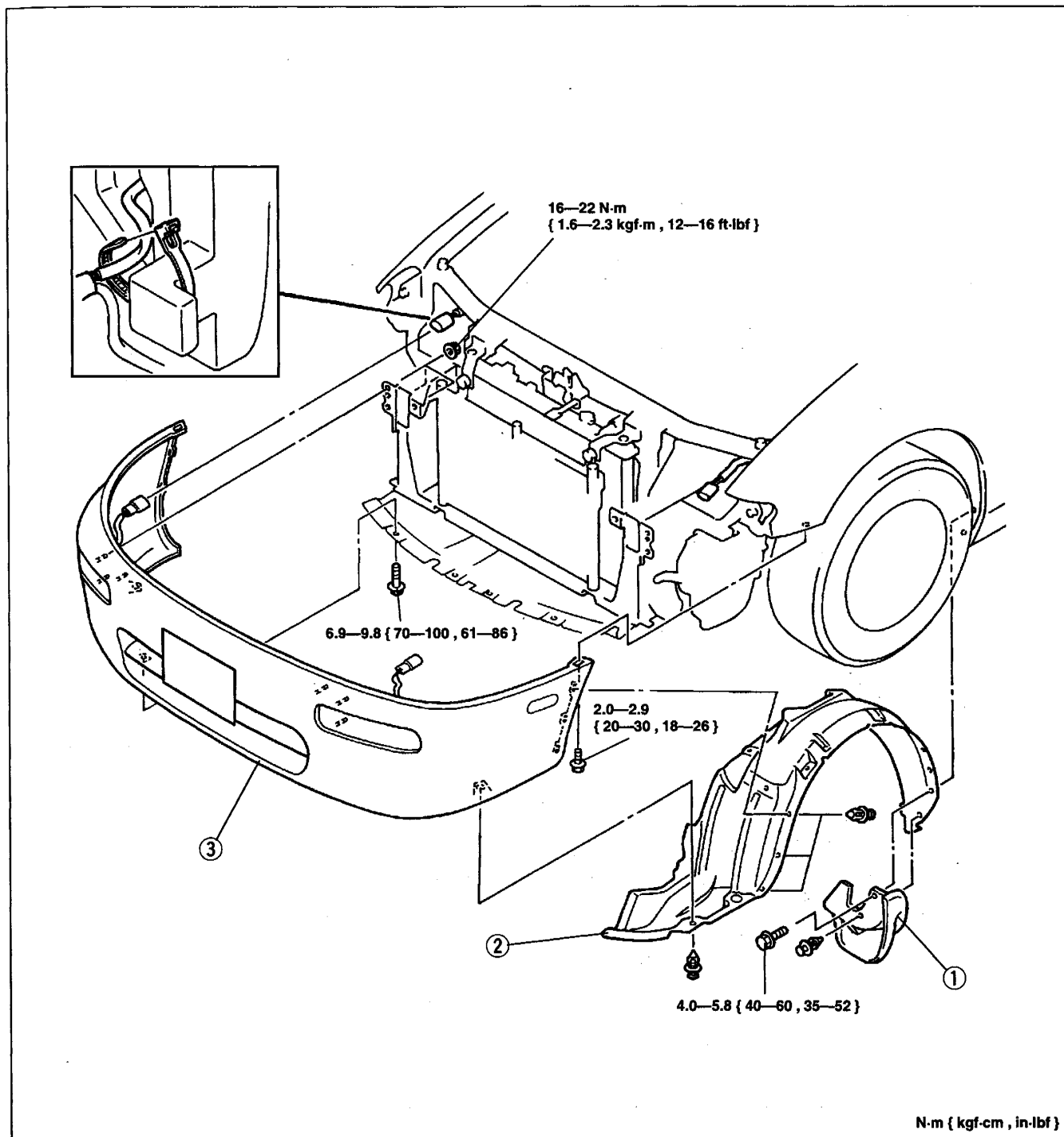

1. Front flap
2. Mud guard

3. Front bumper
Disassembly / Assembly page S1-41

Disassembly / Assembly

1. Disassemble in the order shown in the figure, referring to **Disassembly note**.
2. Assemble in the reverse order of disassembly, referring to **Assembly note**.

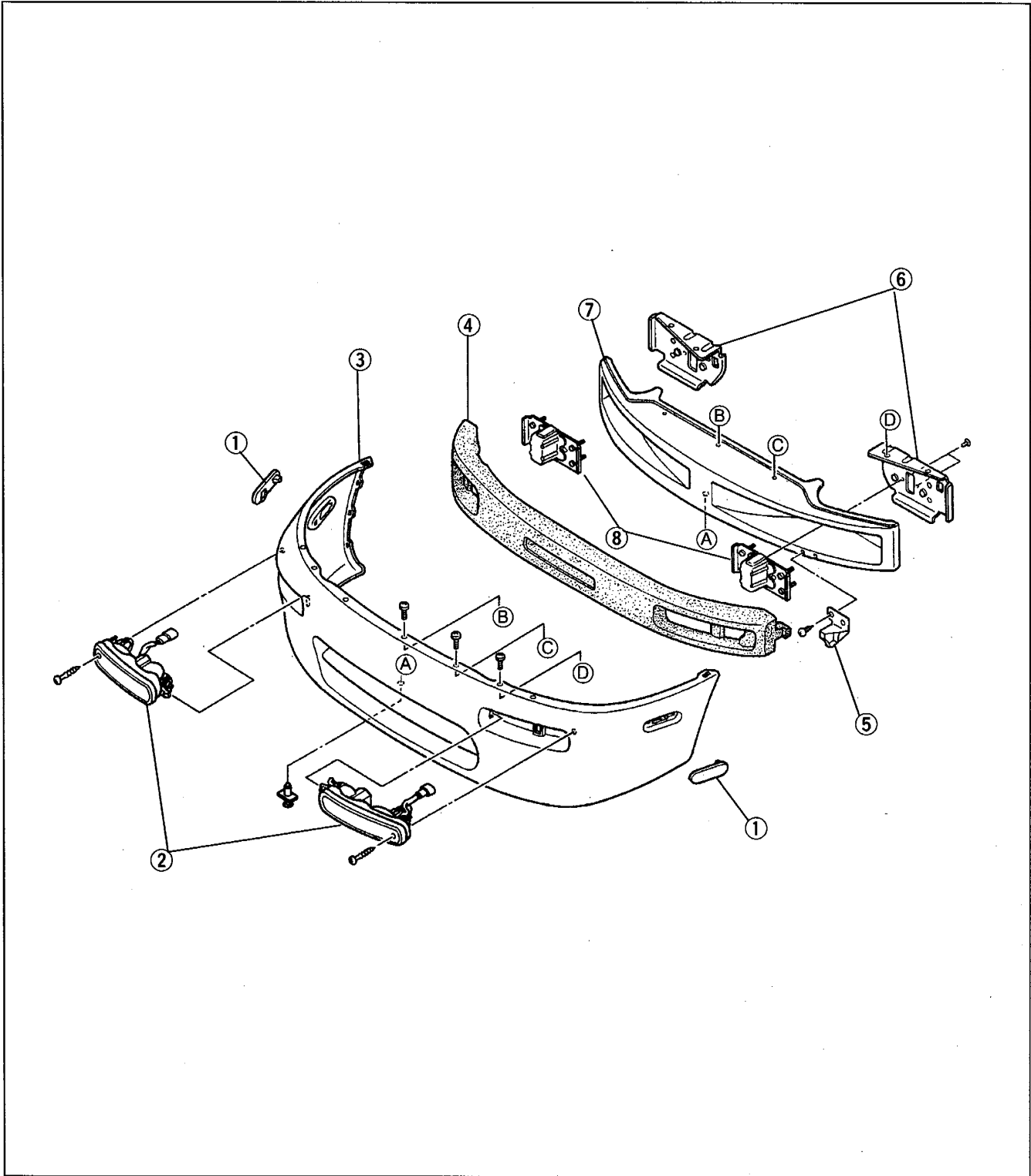

1. Front side marker light
2. Front turn light
Removal / Installation section T1
3. Front bumper fascia
4. Energy-absorbing foam
5. Front bumper panel

6. Set plate
Disassembly note page S1-37
Assembly note page S1-37
7. Front bumper reinforcement
8. Front bumper stay

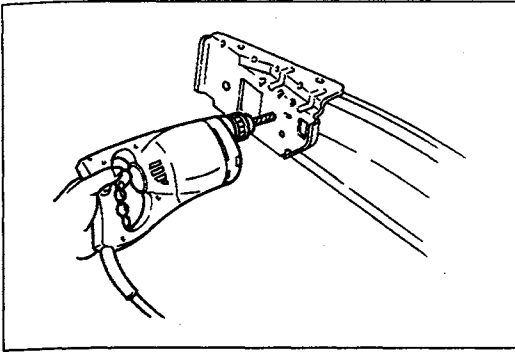
**Disassembly note****Set plate**

Remove the rivets from the front bumper reinforcement by using a drill or cutting pliers.

Drill size: ϕ 7.5 mm { ϕ 0.30 in }

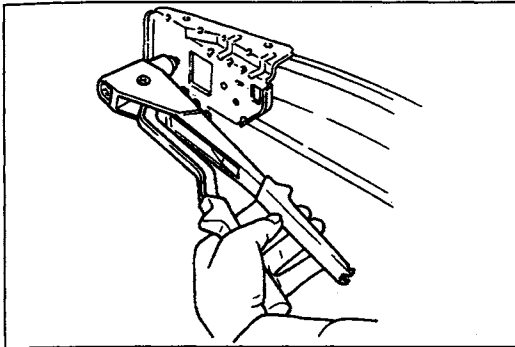
**Assembly note****Set plate**

Rivet the set plate to the front bumper reinforcement by using a hand riveter.

REAR BUMPER

Removal / Installation

1. Disconnect the negative battery cable.
2. Remove the trunk side trim. (Refer to page S1-113.)
3. Remove the combination lights. (Refer to section T1.)
4. Remove the rear end extension. (Refer to page S1-48.)
5. Remove in the order shown in the figure, referring to **Disassembly note**.
6. Install in the reverse order of removal, referring to **Assembly note**.

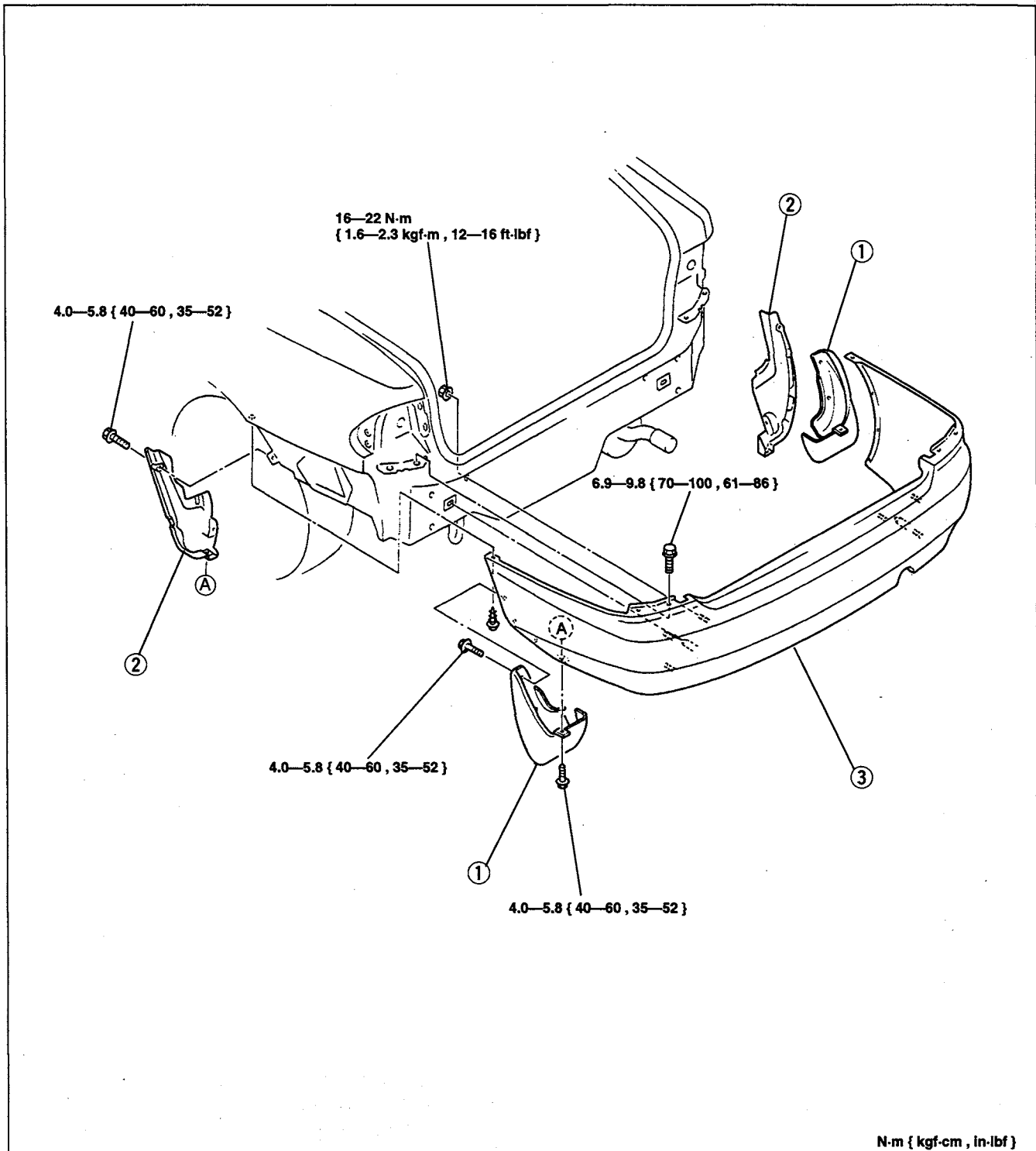

1. Rear flap
2. Splash shield

3. Rear bumper
- Disassembly / Assembly page S1-39

Disassembly / Assembly

1. Disassemble in the order shown in the figure, referring to **Disassembly note**.
2. Assemble in the reverse order of disassembly, referring to **Assembly note**.

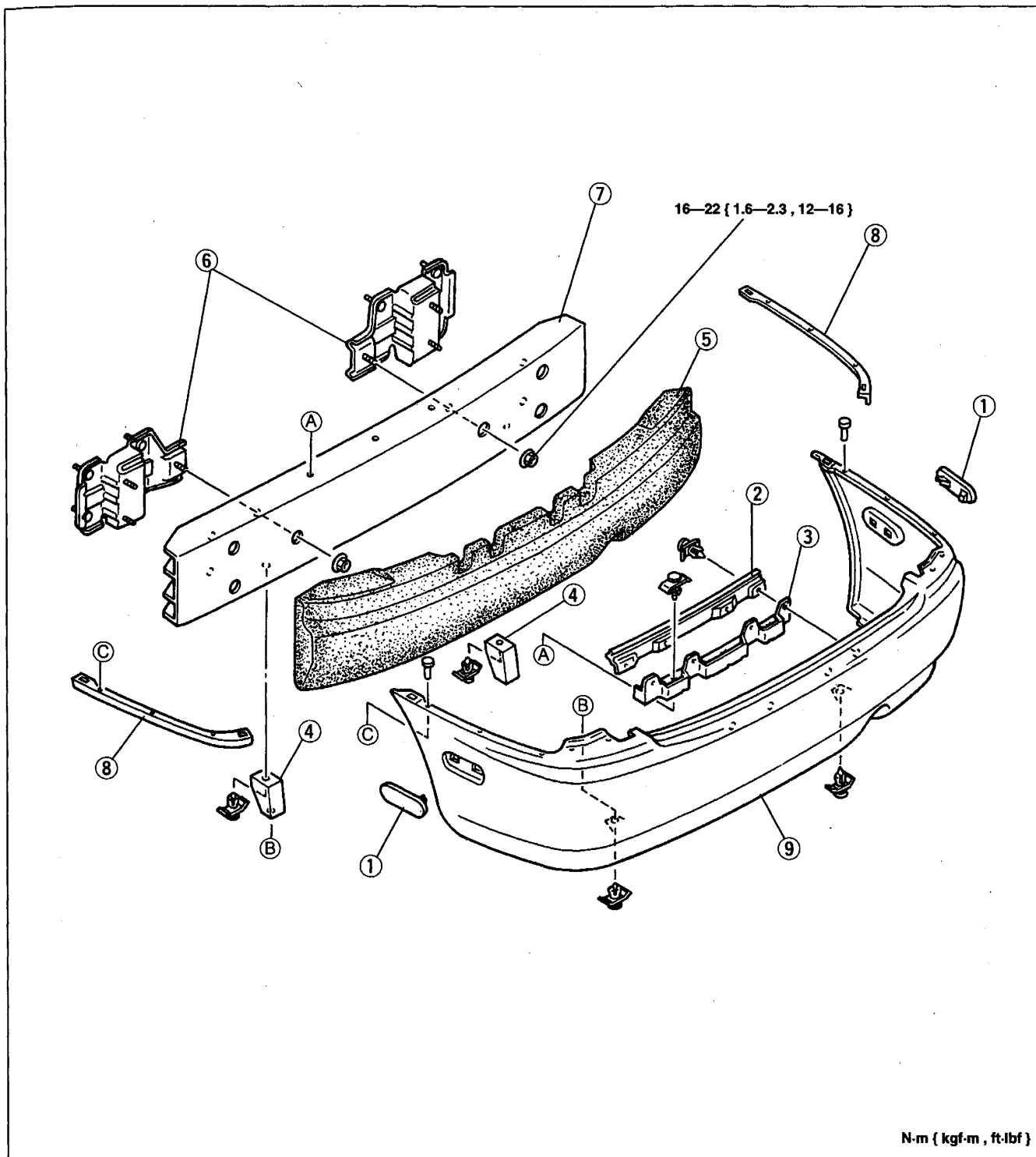

1. Rear side marker
2. Rear bumper retainer
3. Rear bumper bracket
4. Rear bumper bracket
5. Energy-absorbing foam
6. Rear bumper stay

7. Rear bumper reinforcement
8. Rear bumper guard
- Disassembly note page S1-40
- Assembly note page S1-40
9. Rear bumper fascia

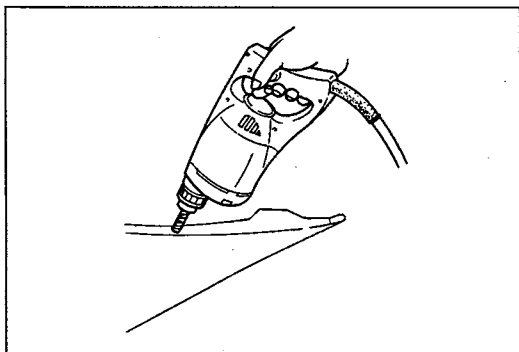
**Disassembly note****Rear bumper guard**

Remove the rivets from the rear bumper fascia by using a drill or cutting pliers.

Drill size: ϕ 3.0 mm { ϕ 0.12 in }

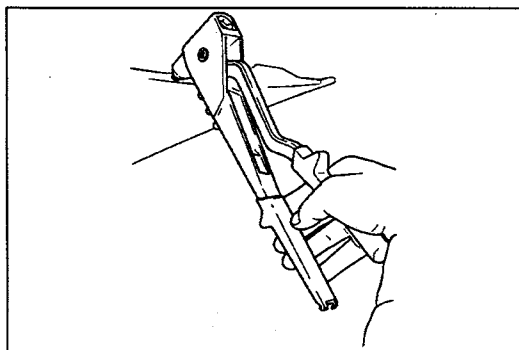
**Assembly note****Rear bumper guard**

Rivet the rear bumper guard to the rear bumper fascia by using a hand riveter.

SPOILER

REAR SPOILER

Removal / Installation

1. Disconnect the negative battery cable.
2. Remove the trunk lid trim. (Refer to page S1-114.)
3. Remove as shown in the figure, referring to **Removal note**.
4. Install in the reverse order of removal.

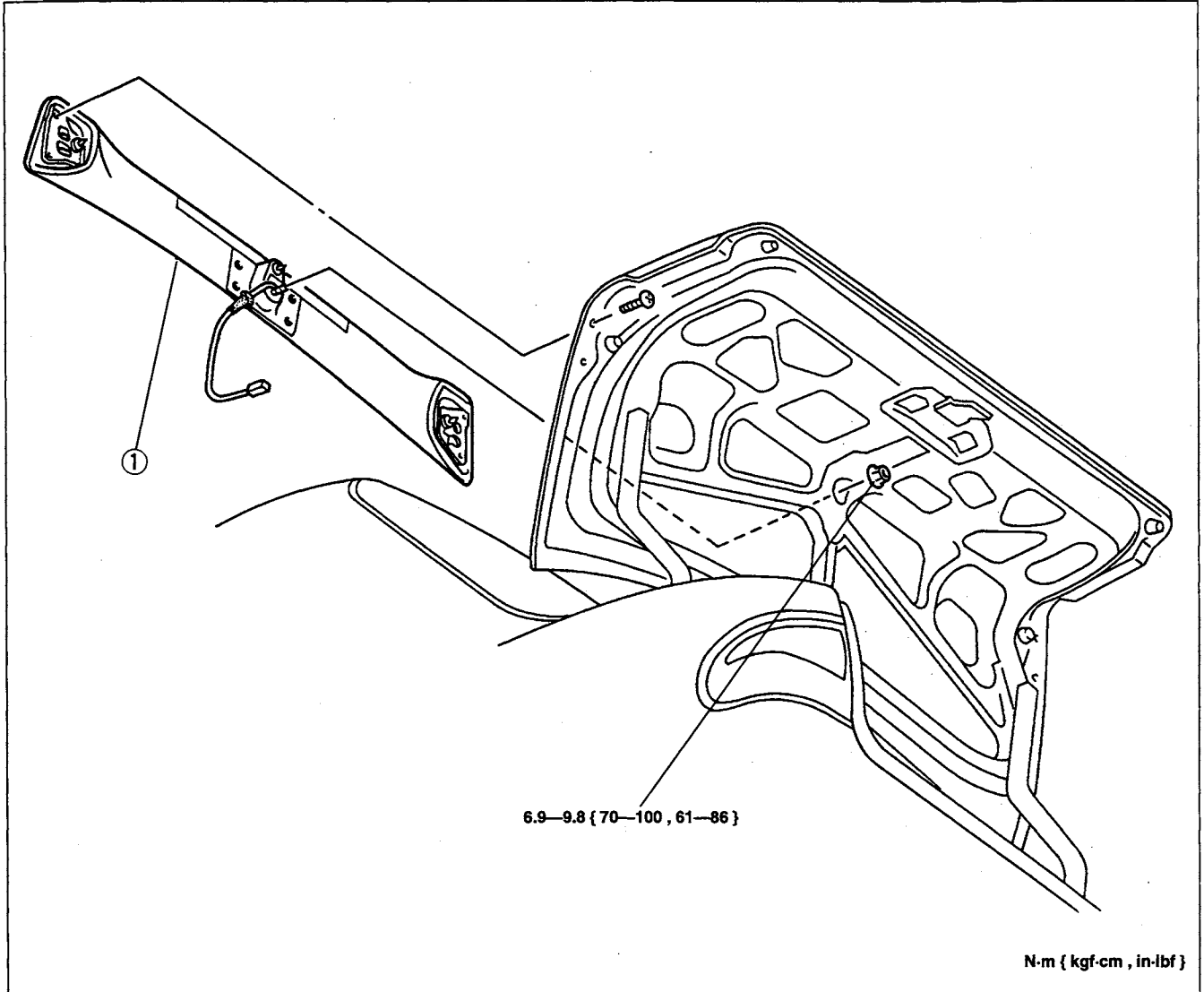

1. Rear spoiler
Removal note below

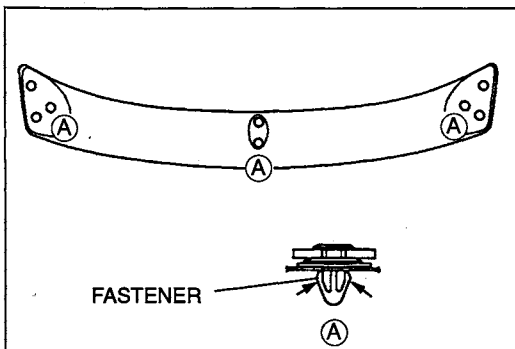

Removal note
Rear spoiler

Squeeze the sides of the fastener and pull the rear spoiler upward to disengage the fasteners from the trunk lid.

RADIATOR GRILLE

RADIATOR GRILLE Removal / Installation

1. Remove in the order shown in the figure.
2. Install in the reverse order of removal.

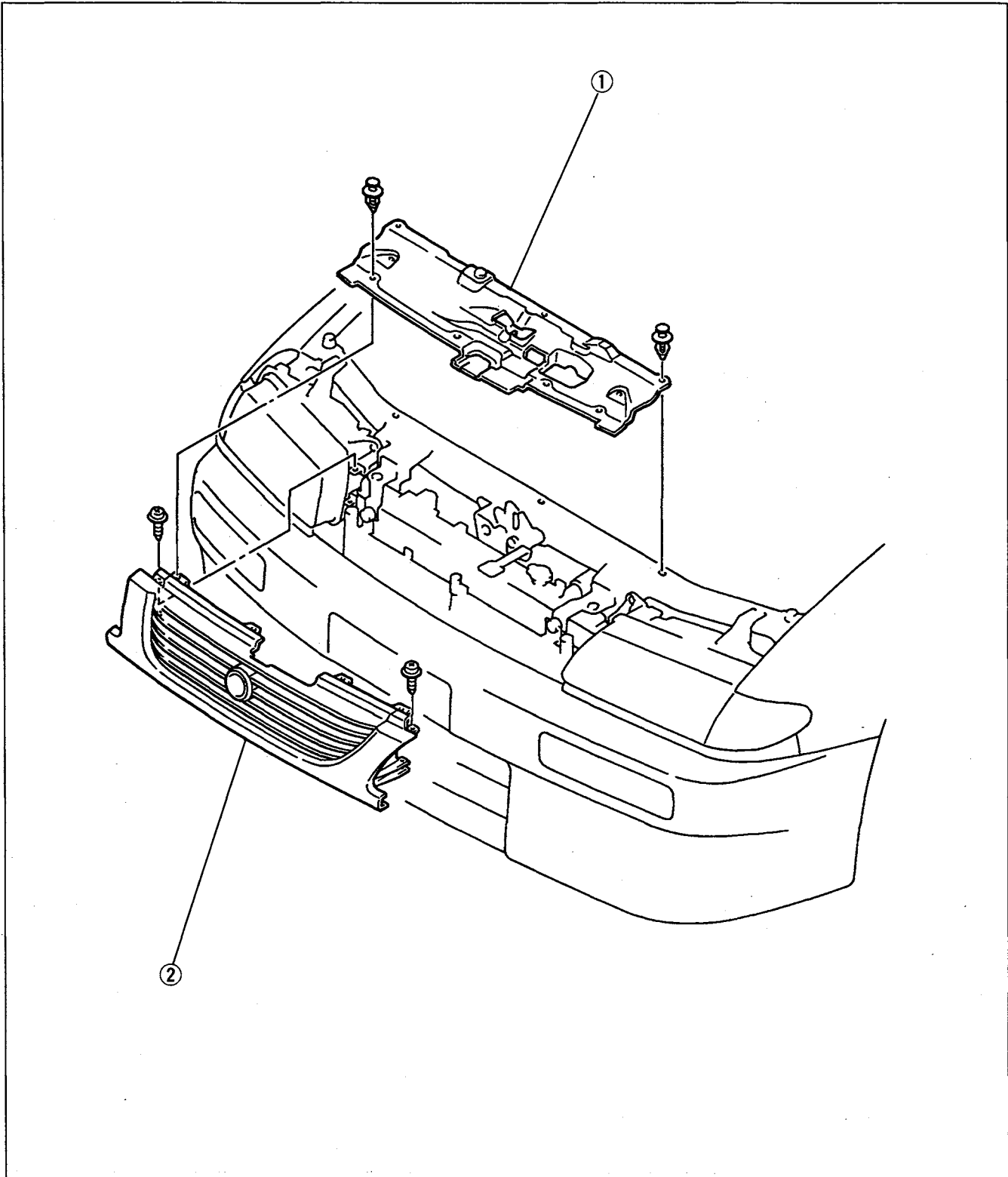

1. Upper seal board

2. Radiator grille

GRILLE LOWER MOLDING**Removal / Installation**

1. Disconnect the negative battery cable.
2. Remove the radiator grille. (Refer to page S1-42.)
3. Remove the headlights. (Refer to section T1.)
4. Remove as shown in the figure.
5. Install in the reverse order of removal.

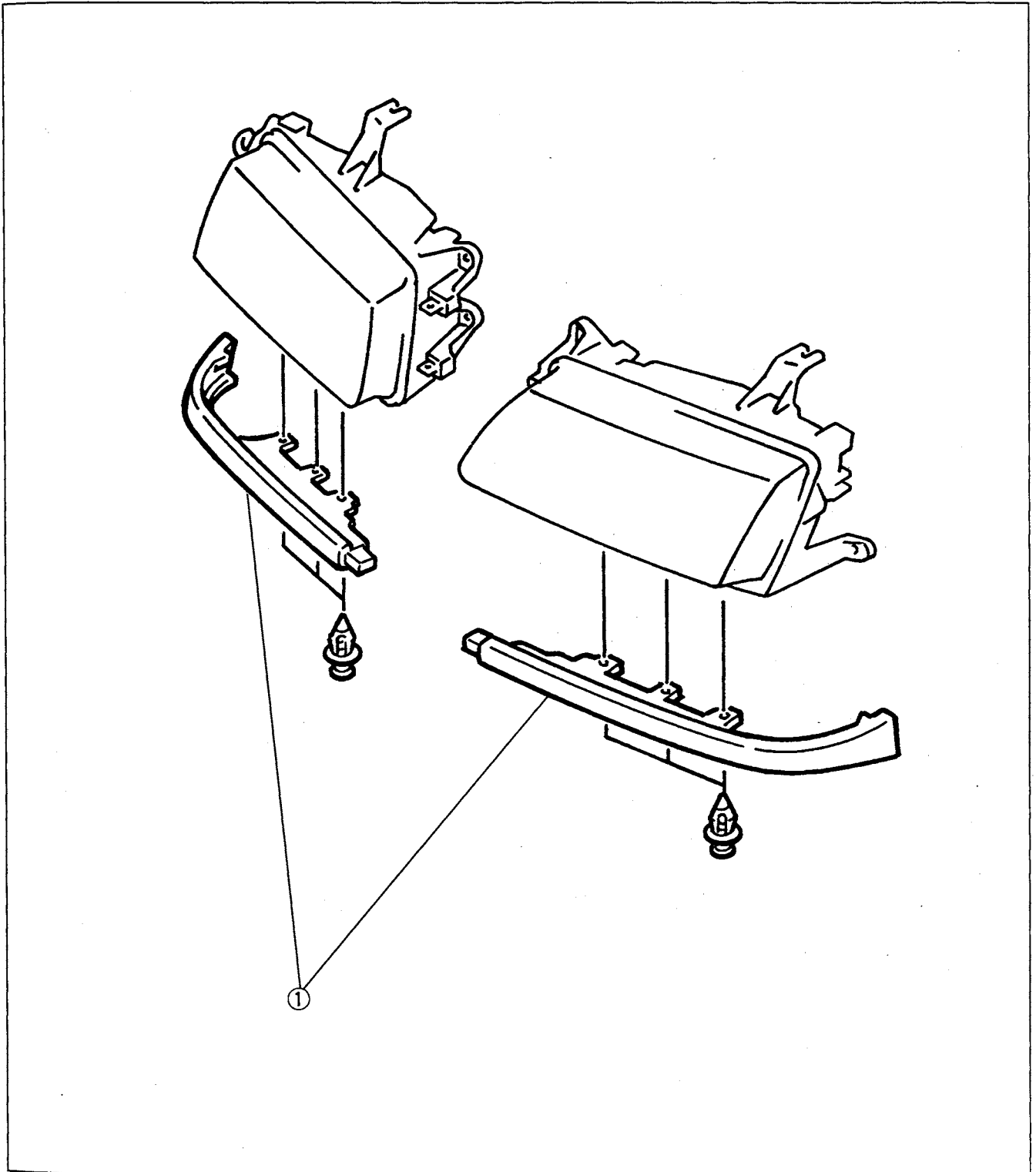

1. Grille lower molding

SIDE GARNISH

SIDE PROTECTOR Removal / Installation

1. Remove in the order shown in the figure, referring to **Removal note**.
2. Install in the reverse order of removal, referring to **Installation note**.

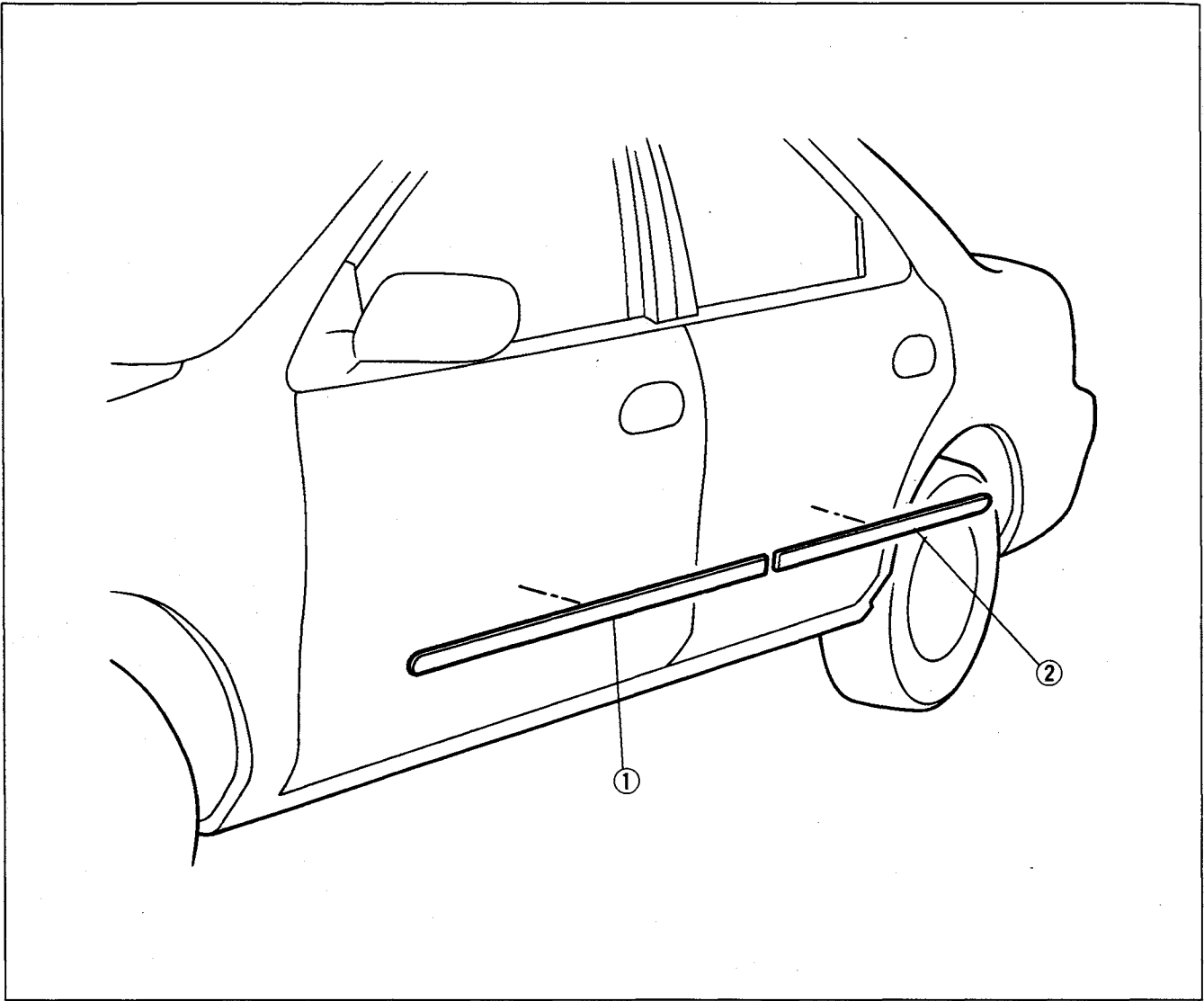

1. Protector No.1
Removal note page S1-45
Installation note page S1-45

2. Protector No.2
Removal note page S1-45
Installation note page S1-45

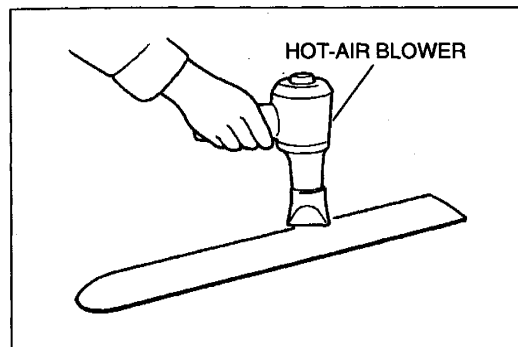
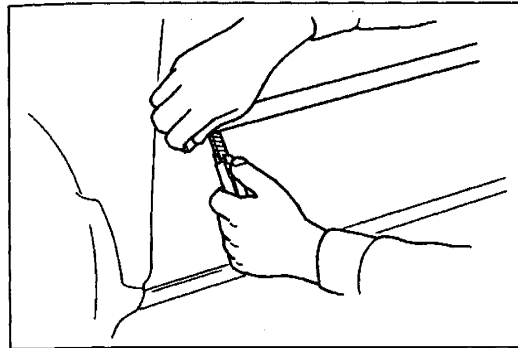
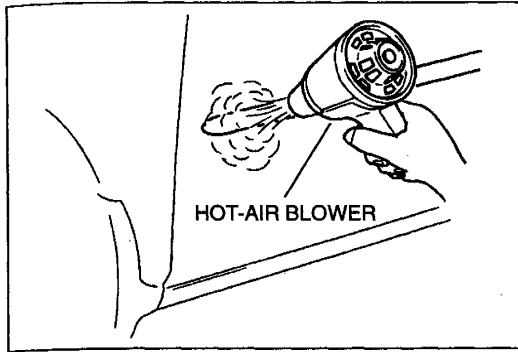

Removal note

Protector No.1, No.2

1. Soften the adhesive by using a hot-air blower.
2. Pry the protector end 20—30 mm { 0.79—1.18 in } by using a flathead screwdriver or razor knife, being careful not to damage the painted surface.
3. Pull the separated portion to remove the protector.

Installation note

Protector No.1, No.2

1. Use a razor knife to remove the adhesive remaining on the body and protector (if the protector will be reused). Remove as much adhesive as possible without damaging the painted surface. If the adhesive is difficult to remove, soften it with a hot-air blower.
2. Remove any grease or dirt from the adhesion surface of the protector (if the protector will be reused) and body.
3. Attach double-sided adhesive tape to the protector as shown (if the protector will be reused).

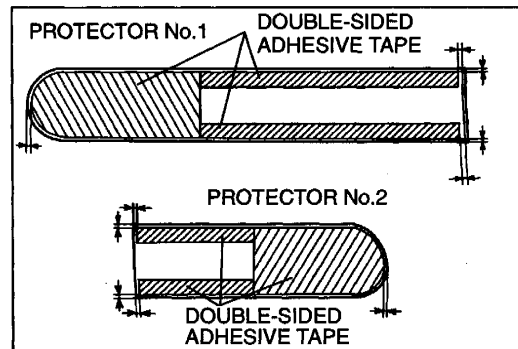

Clearance: 2 ± 1.0 mm { 0.08 ± 0.04 in }

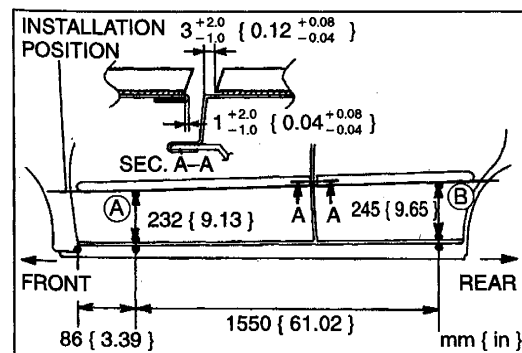

4. Draw a straight line along points (A) and (B) and mark the installation position by using masking tape.

Note

- Adhesion conditions deteriorate if air temperature is below 20 °C { 68 °F }. If this occurs, heat the body before installing the protector.

5. Align the protector on the body and attach it securely.

STONE GUARD

Removal / Installation

1. Remove as shown in the figure.
2. Install in the reverse order of removal.

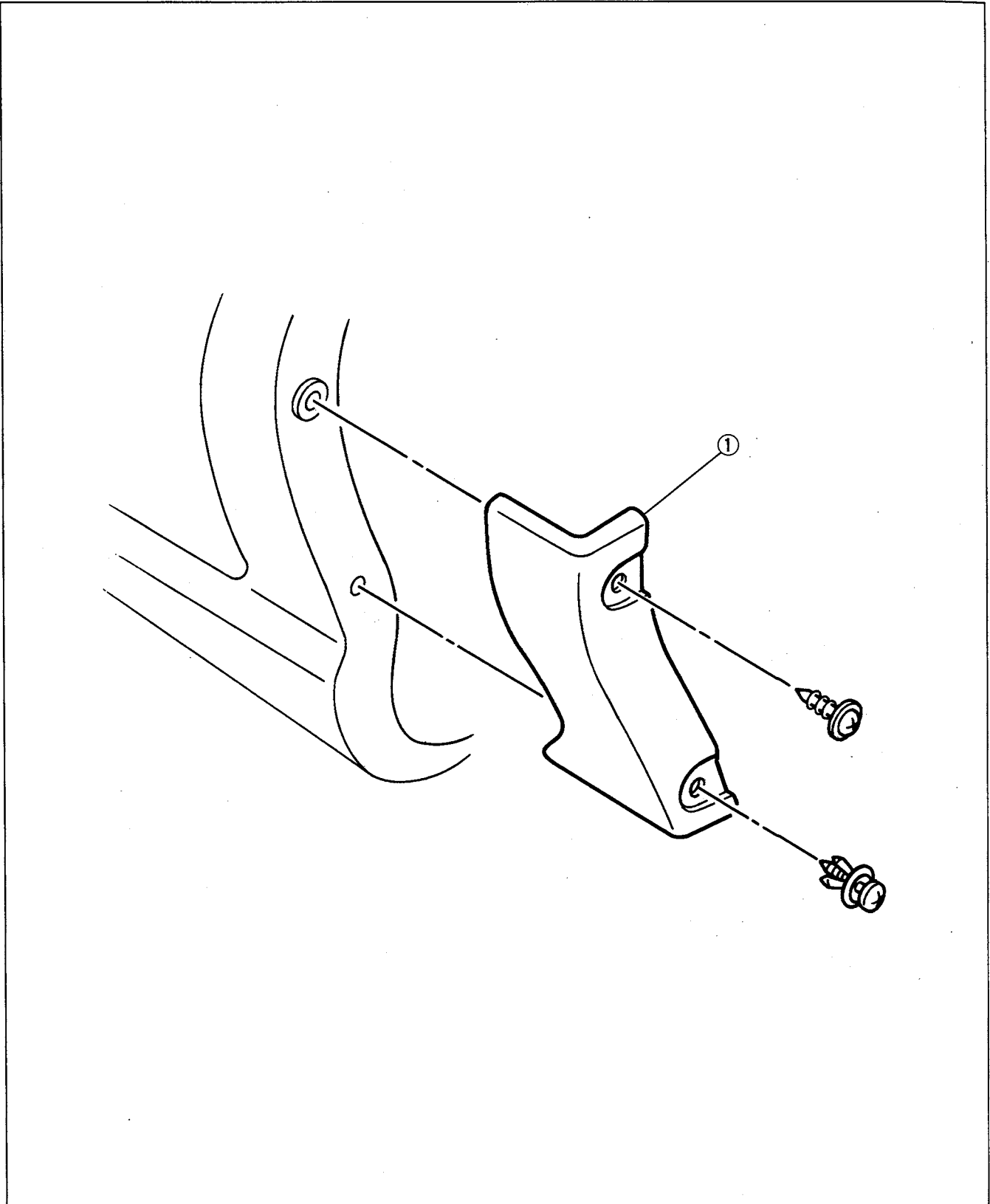

1. Stone guard

EXTRACTOR CHAMBER**EXTRACTOR CHAMBER****Removal / Installation**

1. Disconnect the negative battery cable.
2. Remove the rear bumper. (Refer to page S1-38.)
3. Remove as shown in the figure.
4. Install in the reverse order of removal.

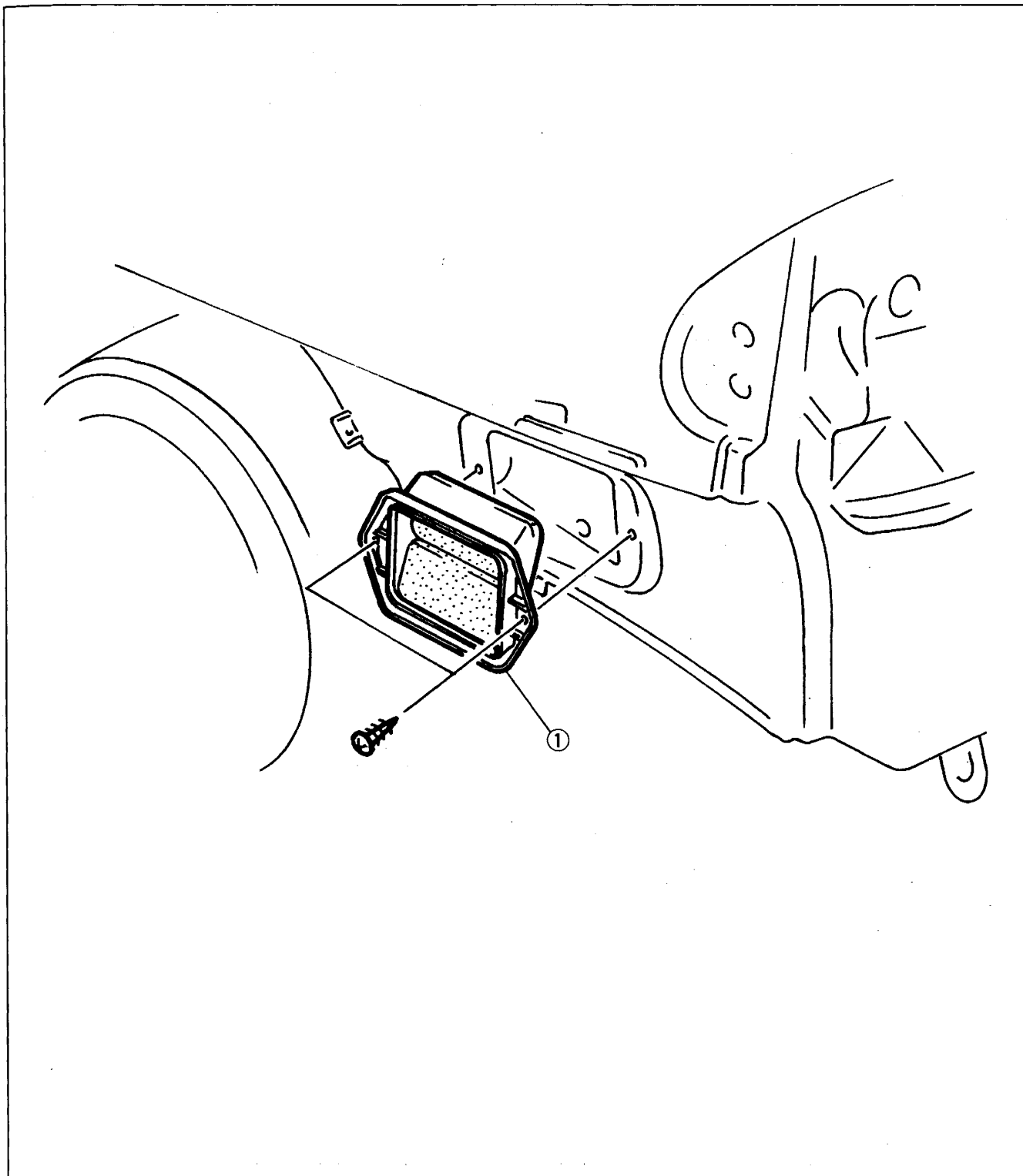

1. Extractor chamber

REAR FINISHER

REAR END EXTENSION

Removal / Installation

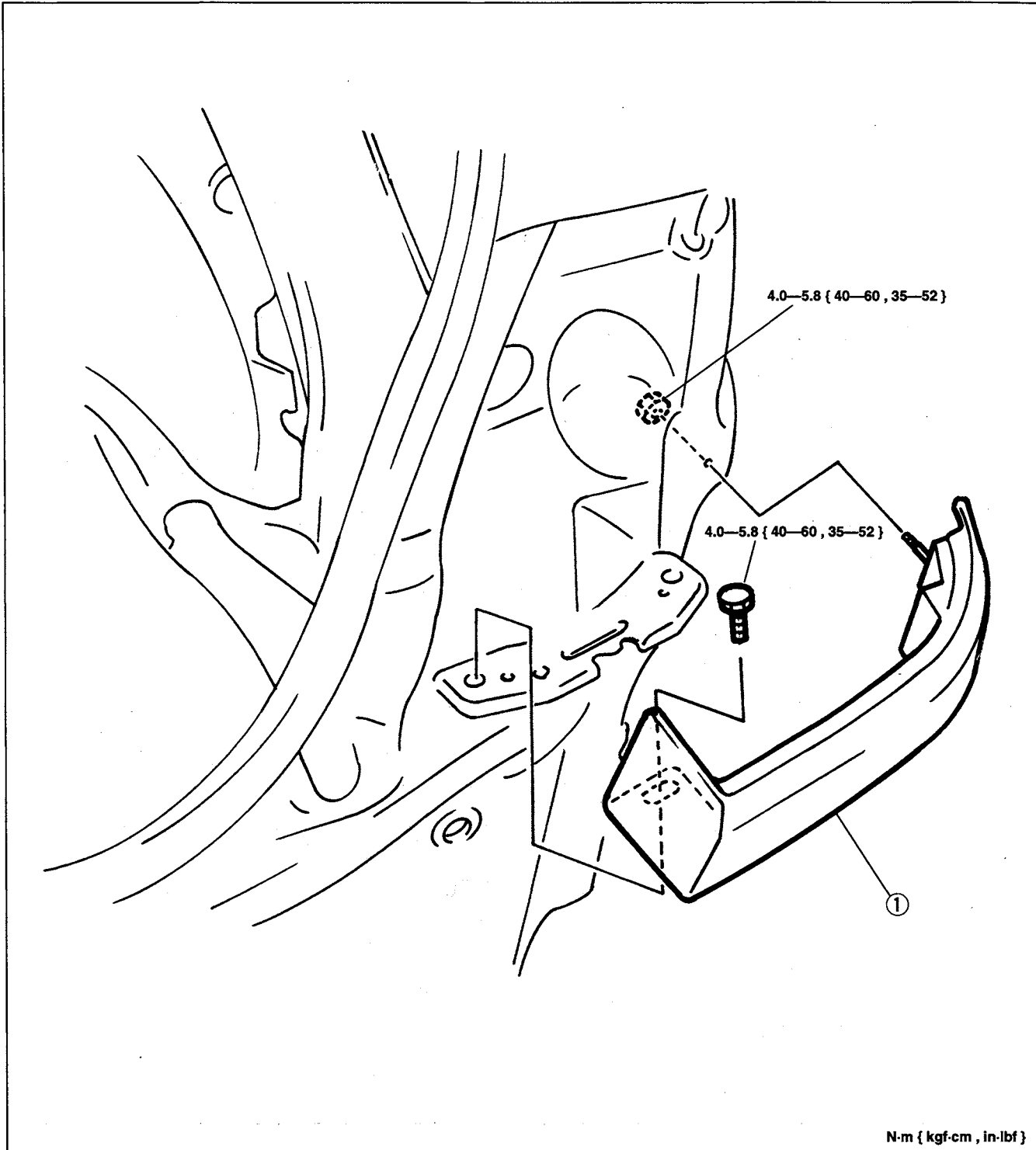

1. Disconnect the negative battery cable.
2. Remove the trunk side trim. (Refer to page S1-113.)
3. Remove the combination lights. (Refer to section T1.)
4. Remove as shown in the figure.
5. Install in the reverse order of removal.



1. Rear end extension

MOLDING

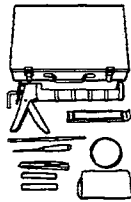
**PREPARATION
SST**

<p>49 0305 870A</p> <p>Tool set, window</p> 	<p>For installation of molding</p>	<p>49 G050 1A0</p> <p>Remover, sealant</p> 	<p>For removal of sealant</p>
---	--	--	---------------------------------------

WINDSHIELD MOLDING

Removal

1. Disconnect the negative battery cable.
2. Remove the cowl grille. (Refer to page S1-58.)
3. Remove as shown in the figure, referring to **Removal note**.

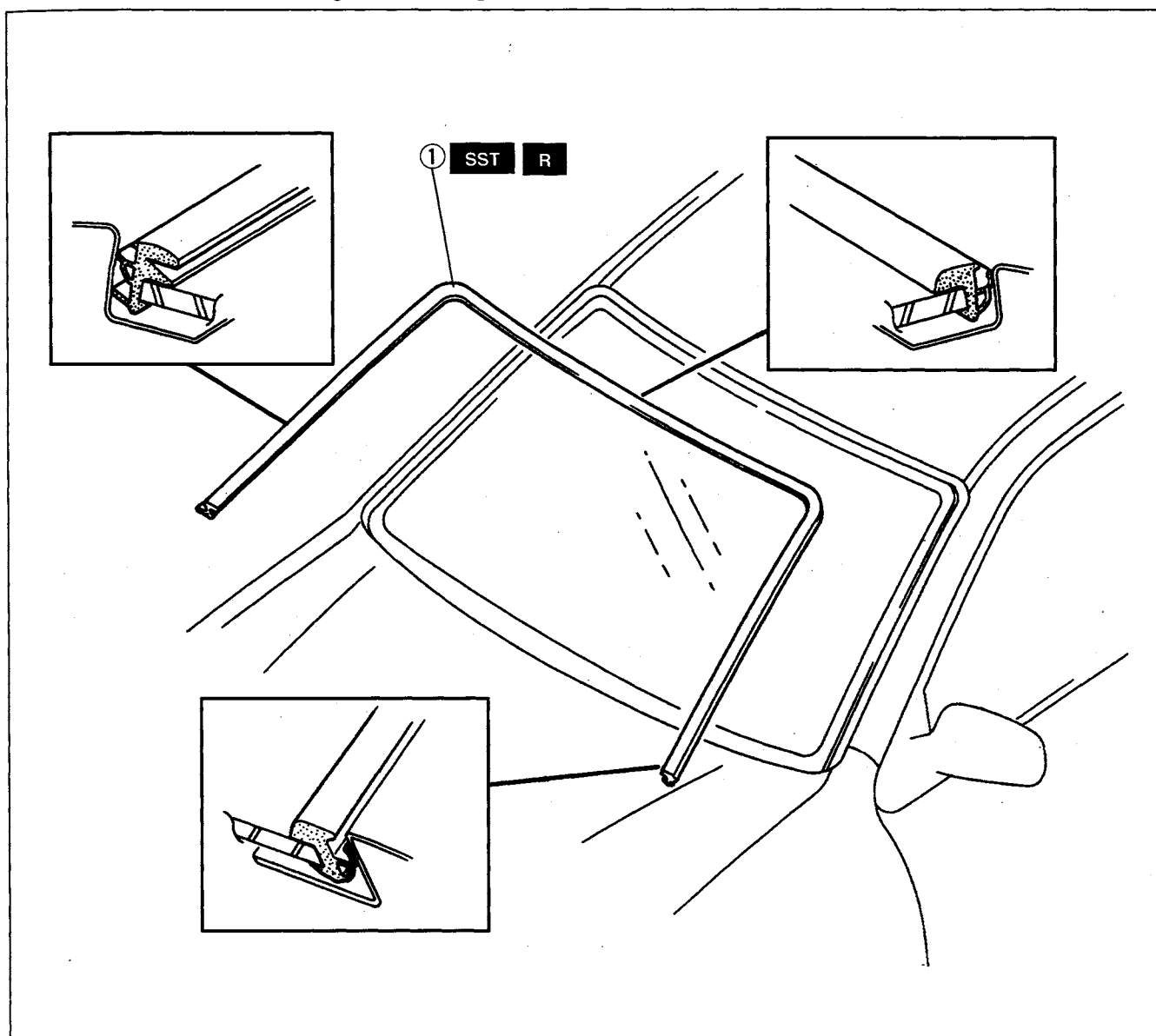

1. Windshield molding
Removal note page S1-50

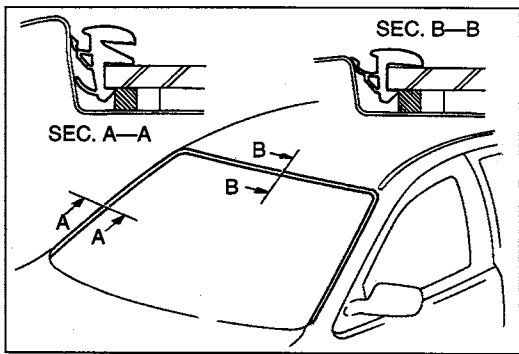

Removal note Windshield molding

The upper molding is attached to the windshield by sealant as shown.

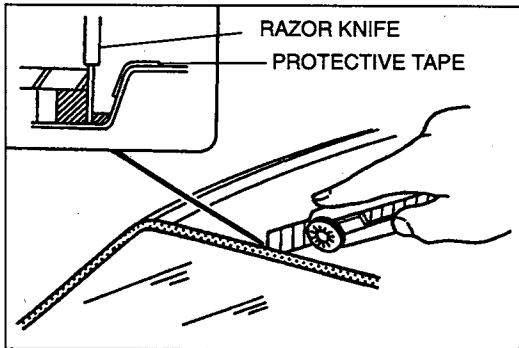

Installation

1. Apply protective tape along the edge of the body to protect it from damage.
2. Cut the sealant by using a razor knife as shown.

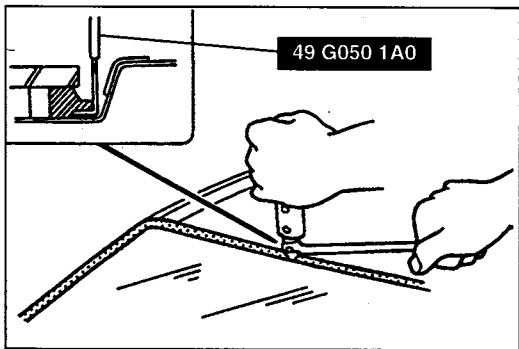

3. Insert the blade of the **SST** into the sealant, and pull on the bar to cut the sealant near the body as shown.

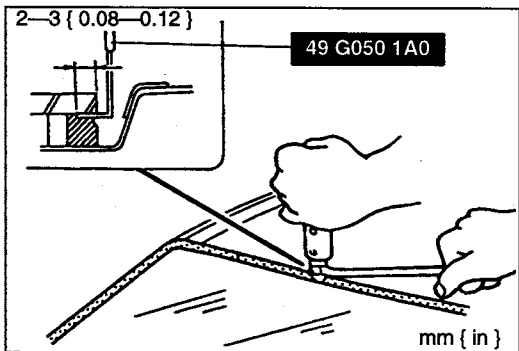

4. Insert the blade of the **SST** into the sealant, and pull on the bar to cut the sealant near the glass as shown.

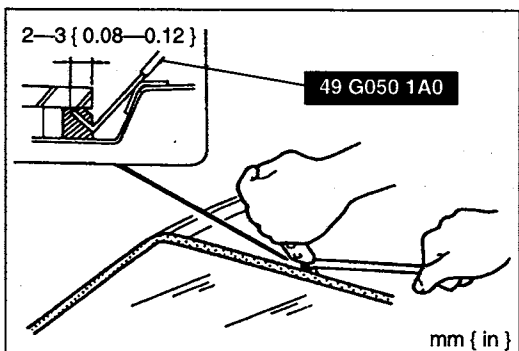

5. Remove as much sealant as possible from between the body and the glass.
6. Carefully clean around the edge of the glass and the adhesion surface of the body.

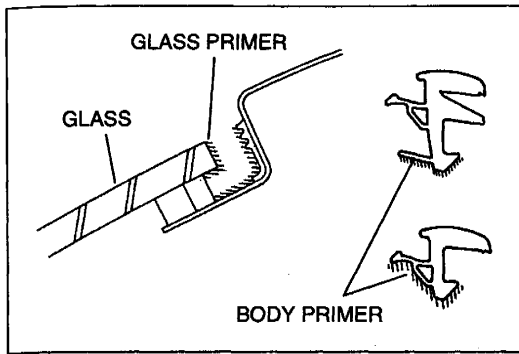

7. Apply primer onto the bonding area of the glass, body, and new windshield molding by using a brush. Use only glass primer on the glass and body primer on the body and molding. Keep the area free of dirt and grease, and do not touch the surface. Allow the primer to dry for approximately **30 minutes**.

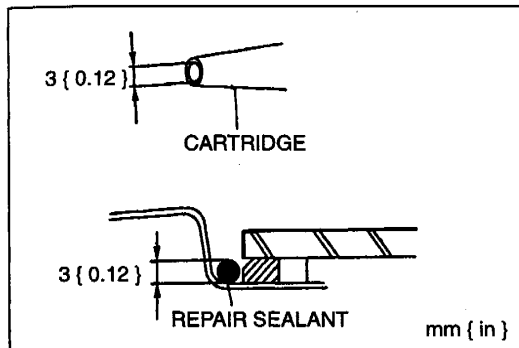

8. Apply a **3 mm { 0.12 in }** bead of repair sealant between the glass and the body.

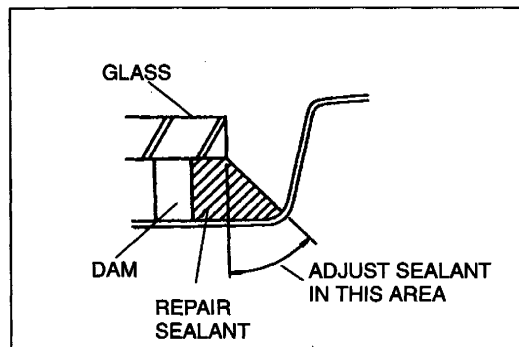

9. Reshape the repair sealant as shown if necessary.

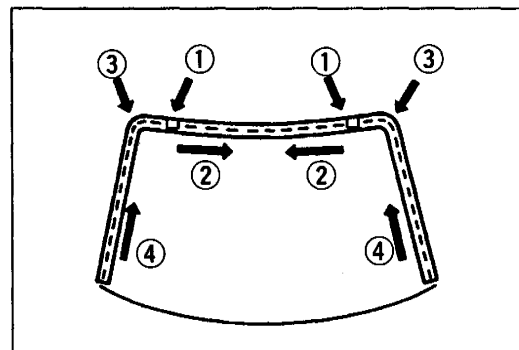

10. Install the windshield molding before the sealant has hardened.

- (1) Align the marks on the molding to the roof inner line.
- (2) Install the upper part of the molding.
- (3) Install the corner part of the molding.
- (4) Install the side parts of the molding, starting from the bottom and then toward the top.

Hardening time of repair sealant

Temperature	Surface hardening time	Time required until car can be put into service
5 °C { 41 °F }	Approx. 1.5 hr	12 hr
20 °C { 68 °F }	Approx. 1 hr	4 hr
35 °C { 95 °F }	Approx. 10 min	2 hr

11. Check for water leaks. If a leak is found, wipe the water off well and repeat the installation.

REAR WINDOW MOLDING

Removal / Installation

1. Remove in the order shown in the figure.
2. Install in the reverse order of removal.

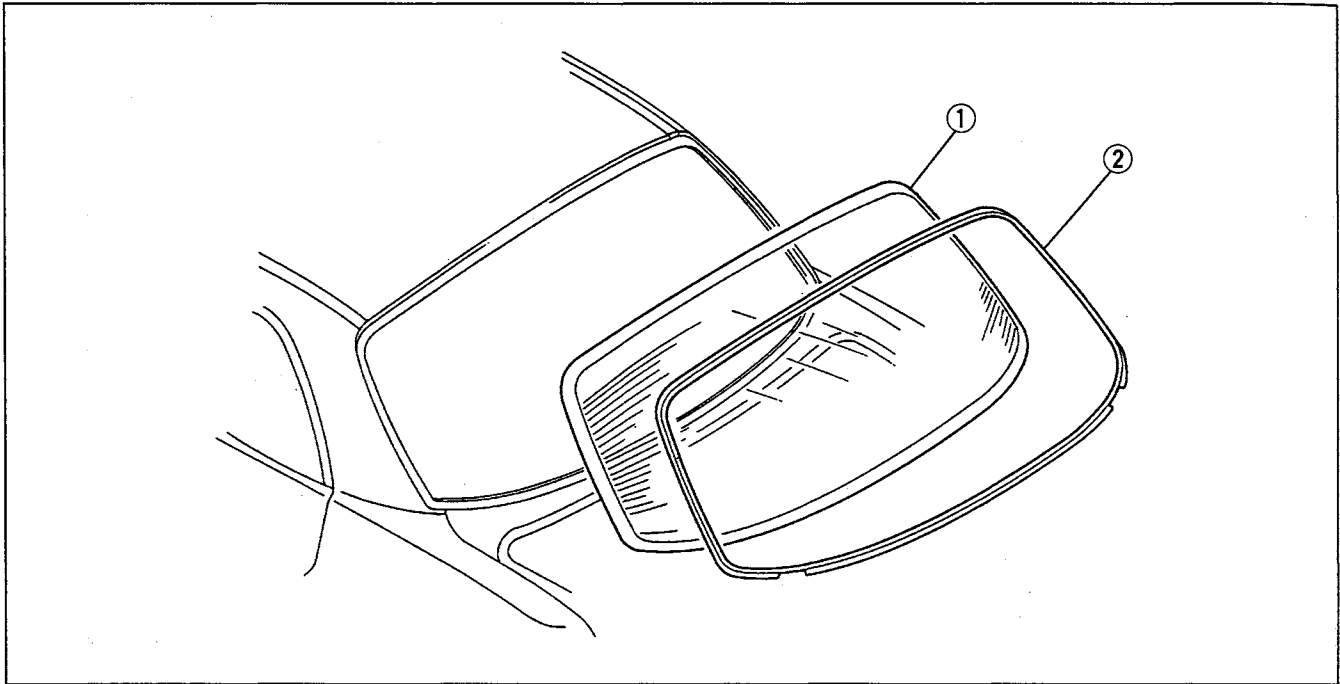

1. Rear window glass

Removal page S1-71
Installation page S1-73

2. Rear window molding

FRONT BELTLINE MOLDING**Removal / Installation**

1. Disconnect the negative battery cable.
2. Remove the power outside mirror. (Refer to page S1-59.)
3. Remove the front door glass. (Refer to page S1-12.)
4. Remove as shown in the figure, referring to **Removal note**.
5. Install in the reverse order of removal.

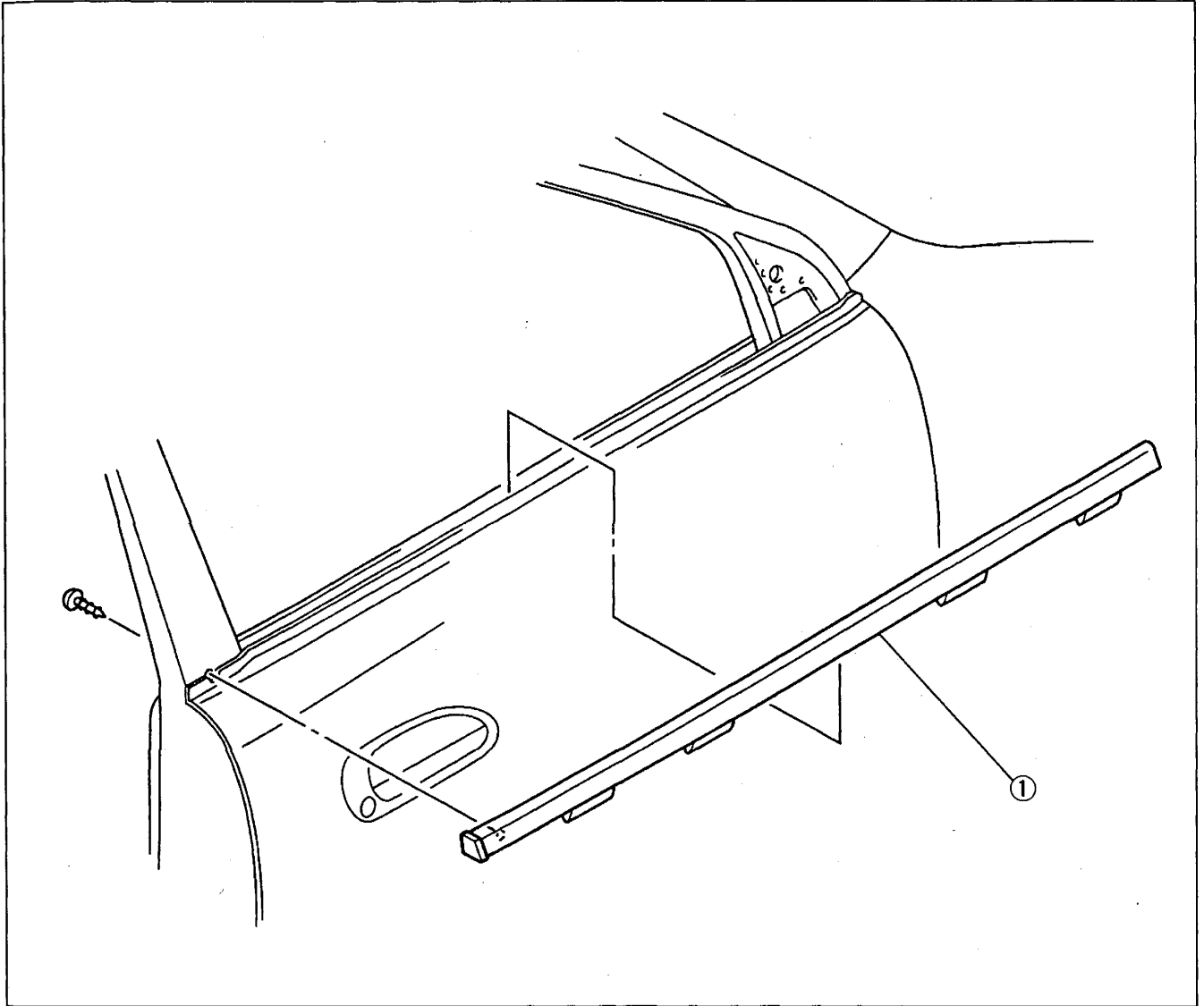
**1. Front beltline molding**

Removal note below

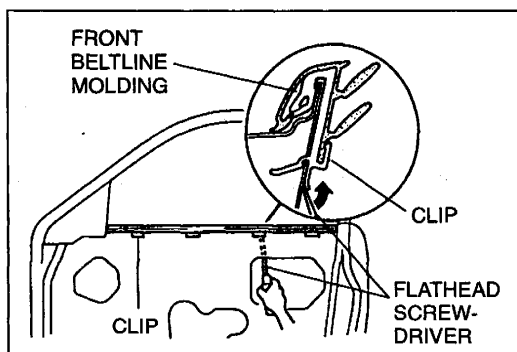
**Removal note****Front beltline molding**

1. Remove the installation screw.
2. Insert a flathead screwdriver which has been wrapped in tape under the clip as shown.
3. Lift the screwdriver and pull up on the molding to remove it.

REAR BELTLINE MOLDING

Removal / Installation

1. Disconnect the negative battery cable.
2. Remove the rear door glass. (Refer to page S1-14.)
3. Remove as shown in the figure, referring to **Removal note**.
4. Install in the reverse order of removal.

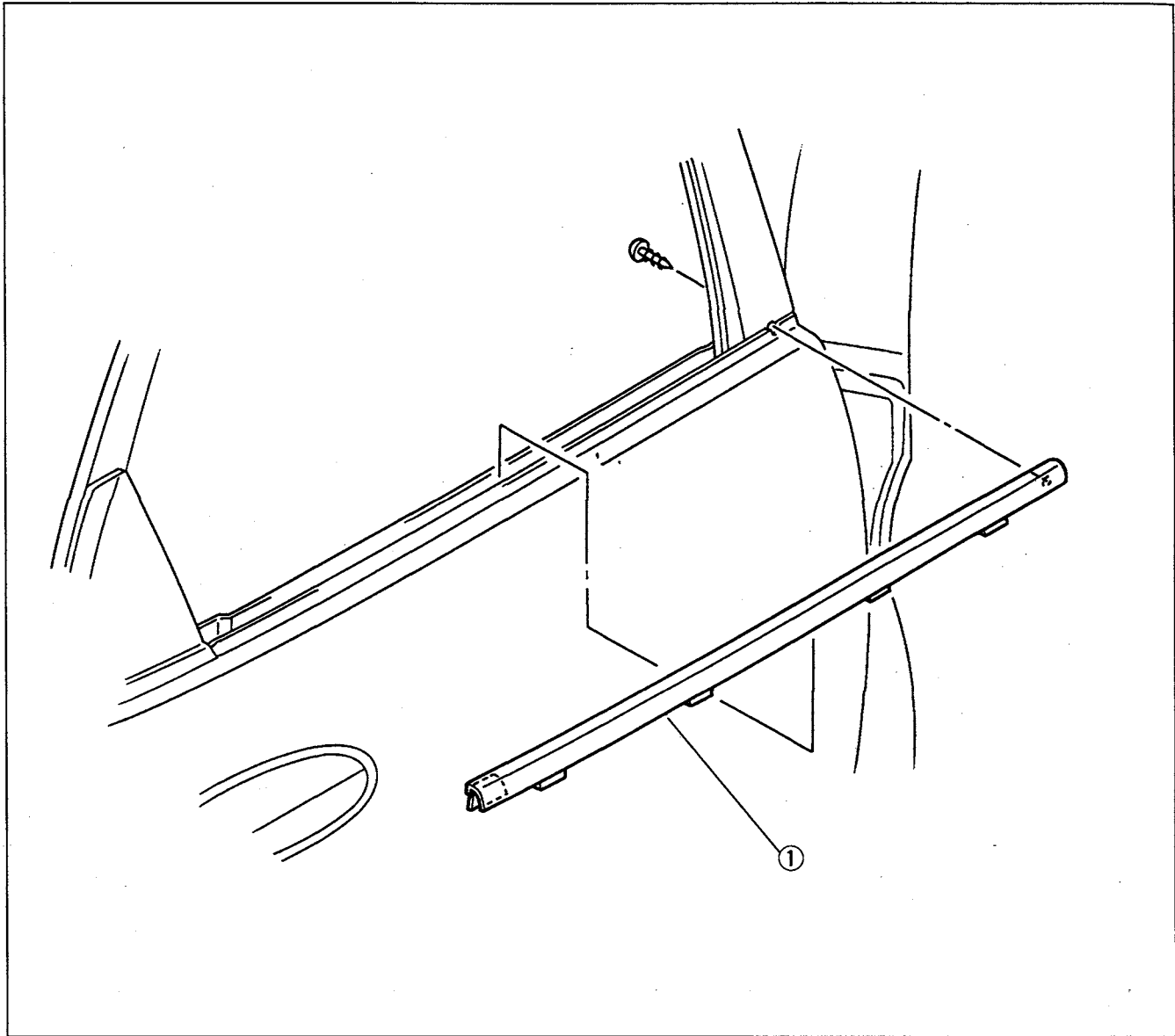

1. Rear beltline molding

Removal note below

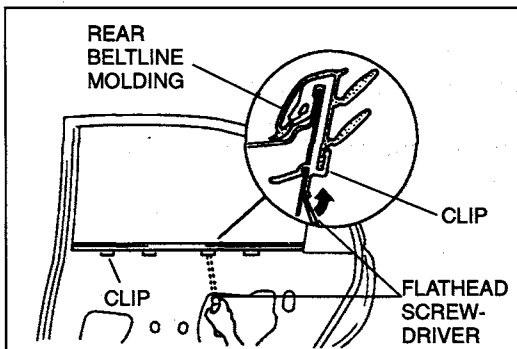

Removal note

Rear beltline molding

1. Remove the installation screw.
2. Insert a flathead screwdriver which has been wrapped in tape under the clip as shown.
3. Lift the screwdriver and pull up on the molding to remove it.

ROOF MOLDING
Removal / Installation

1. Remove as shown in the figure.
2. Install in the reverse order of removal, referring to **Installation note**.

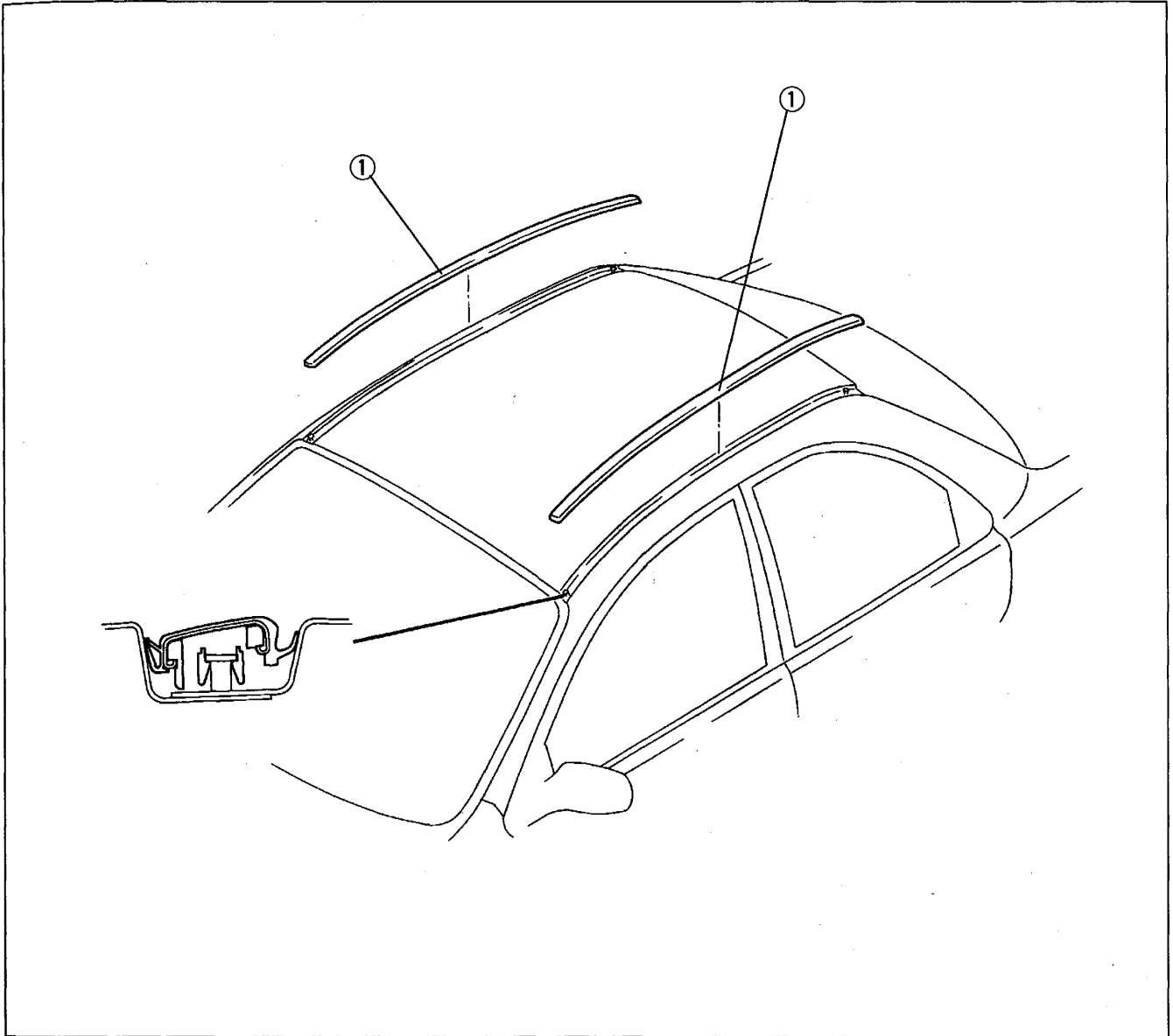

1. Roof molding
Installation note below

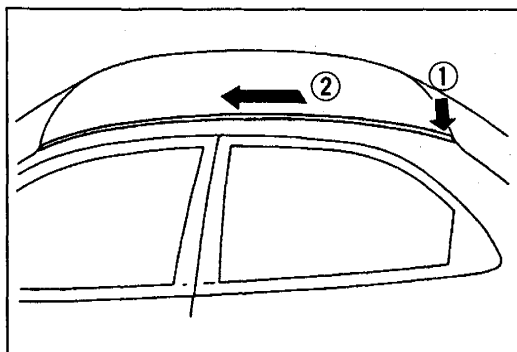

Installation note
Roof molding

1. Locate the roof molding based on the rear end clip and press it. (①)
2. Install the roof molding pushing it down from rear toward front end. (②)

DOOR GARNISH

Removal / Installation

1. Remove the rear beltline molding. (Refer to page S1-54.)
2. Remove as shown in the figure.
3. Install in the reverse order of removal.

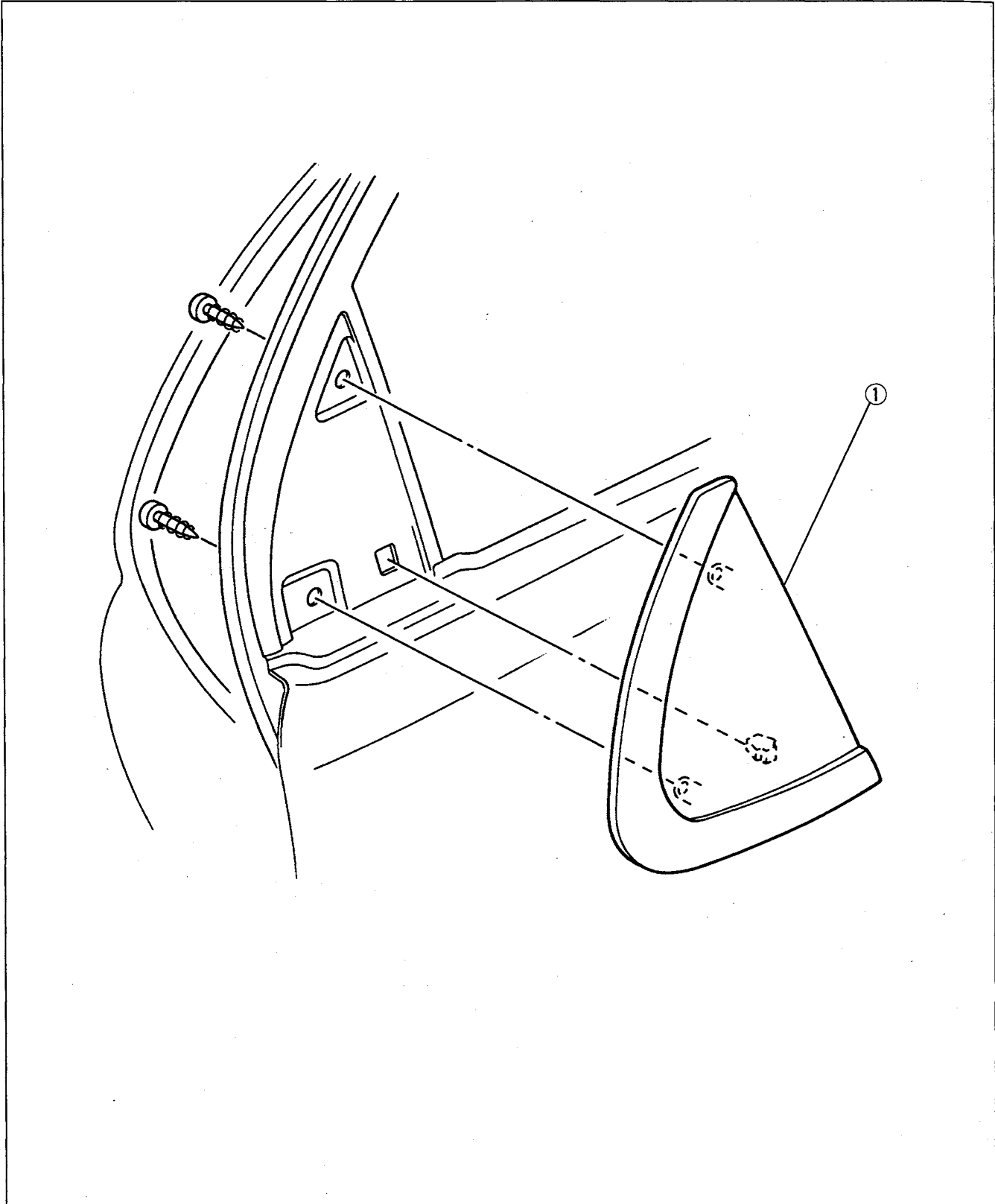

1. Door garnish

GLASS STOPPER
Removal / Installation

1. Disconnect the negative battery cable.
2. Remove the cowl grille. (Refer to page S1-58.)
3. Remove as shown in the figure.
4. Install in the reverse order of removal.

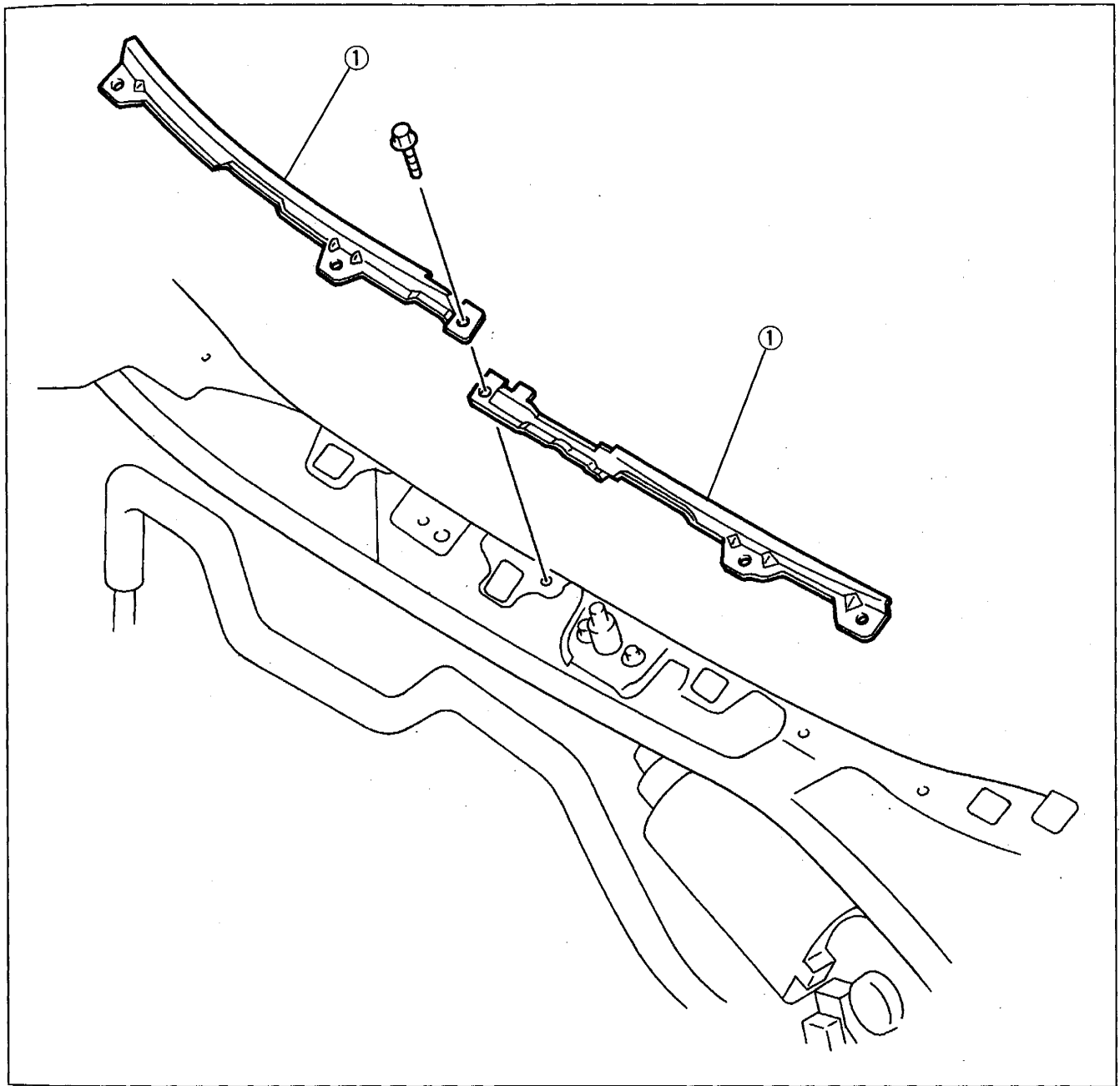

1. Glass stopper

COWL GRILLE

COWL GRILLE

Removal / Installation

1. Remove the windshield wiper arms. (Refer to section T1.)
2. Remove in the order shown in the figure.
3. Install in the reverse order of removal.

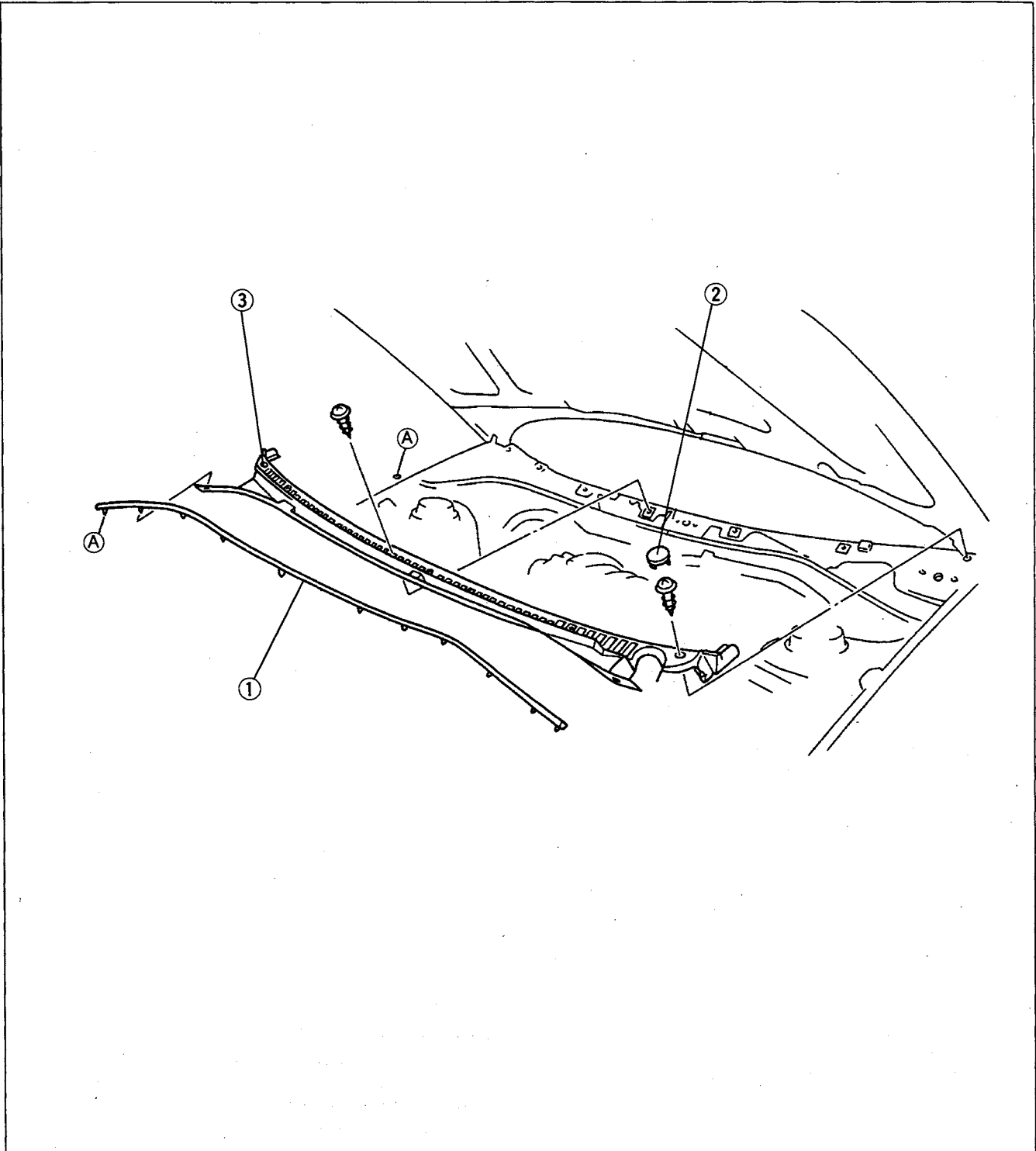

1. Cowl seal weatherstrip
2. Cowl cap

3. Cowl grille

OUTSIDE MIRROR

**OUTSIDE MIRROR
Removal / Installation**

1. Disconnect the negative battery cable if equipped with a power outside mirror.

Note

- Remove the door screen carefully so that it may be reused.

2. Remove in the order shown in the figure.
3. Install in the reverse order of removal.

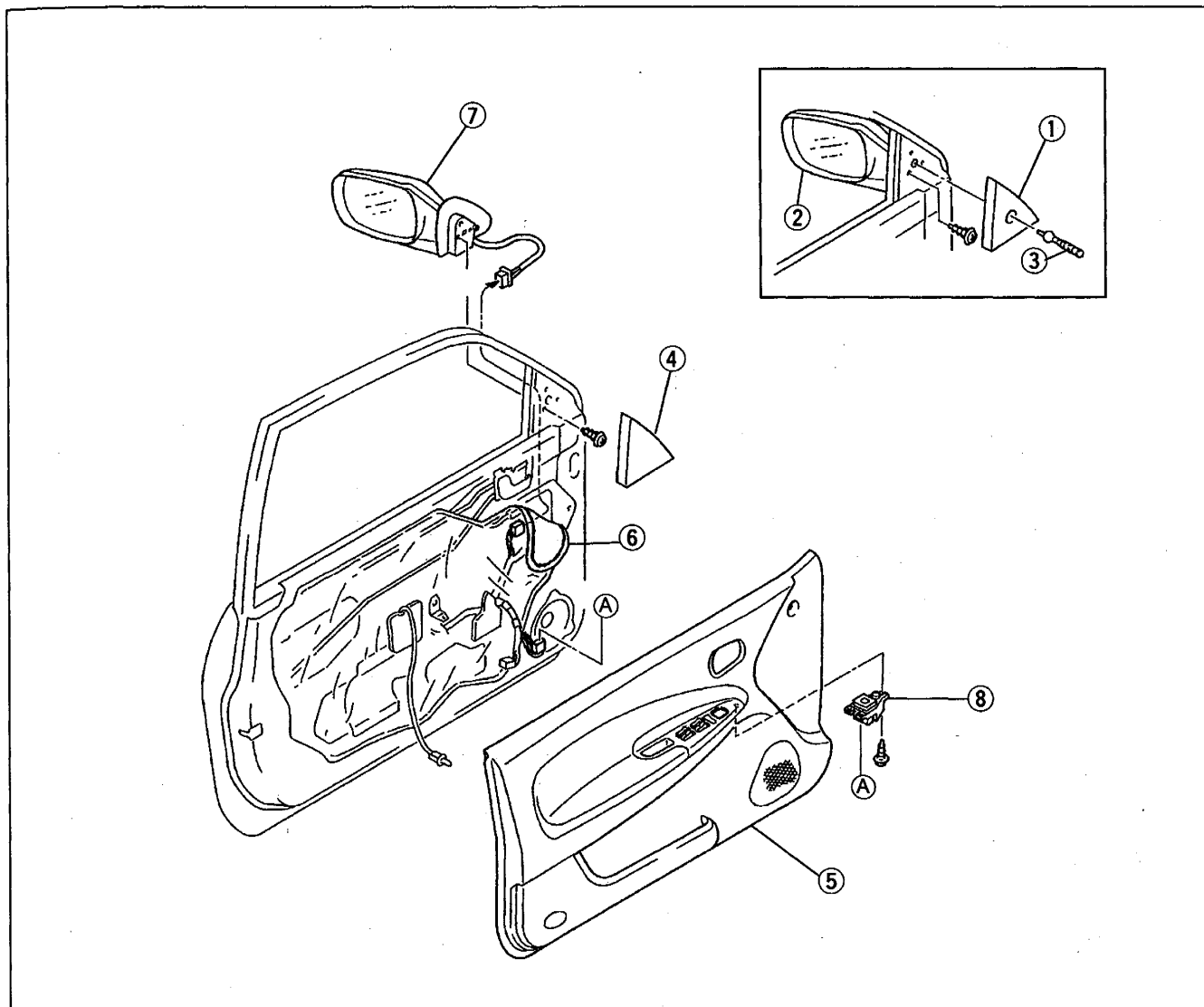

Manual outside mirror

1. Inner garnish
2. Manual outside mirror
Replacement of mirror glass . page S1- 60
3. Knob

Power outside mirror

4. Inner garnish
5. Front door trim
Removal / Installation page S1-107

6. Door screen

7. Power outside mirror
Replacement of mirror glass . page S1- 60
Inspection page S1- 61

Power outside mirror switch

- 5 Front door trim
Removal / Installation page S1-107
8. Power outside mirror switch
Inspection page S1- 61

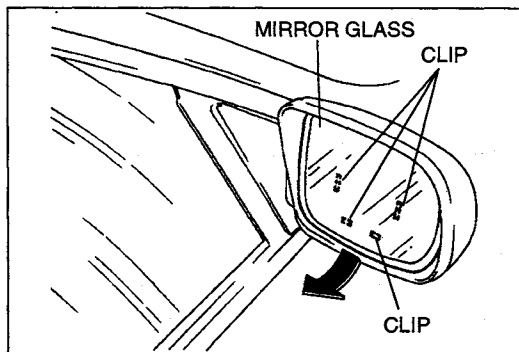

Replacement of Mirror Glass

(Power outside mirror)

Removal

1. Push the top of the mirror glass.
2. Pull the bottom of the mirror glass and remove the mirror glass from the frame.

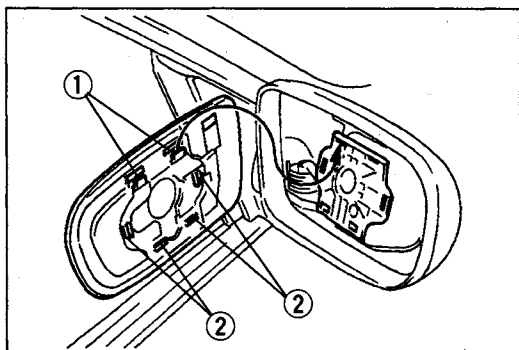

Installation

1. Hook the top of the mirror glass onto the frame.
2. Press the sides and bottom of the mirror glass onto the frame.

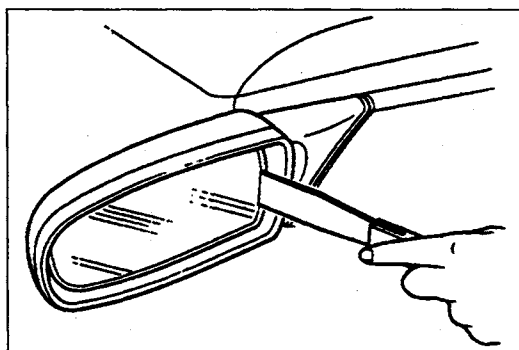

(Manual outside mirror)

Removal

1. Warm the frame and the mirror glass by using a hot-air blower.
2. Insert a scraper between the mirror glass and the frame, and pry the glass loose.
3. Remove the remaining adhesive.

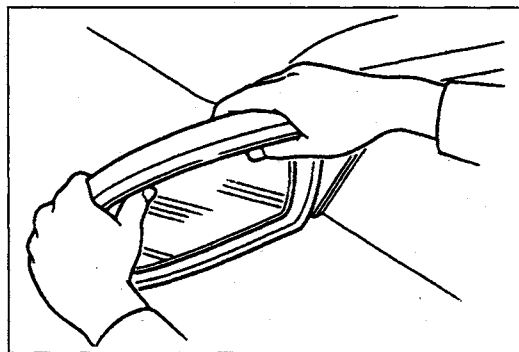

Installation

1. Warm the adhesive surface of the frame and the mirror by using a hot-air blower. If the frame is stained with oil, degrease it.
2. Peel off the wax paper from the double-sided adhesive tape on the rear side of the new mirror glass.
3. Install the glass in the mirror frame and gently press it in to secure it.

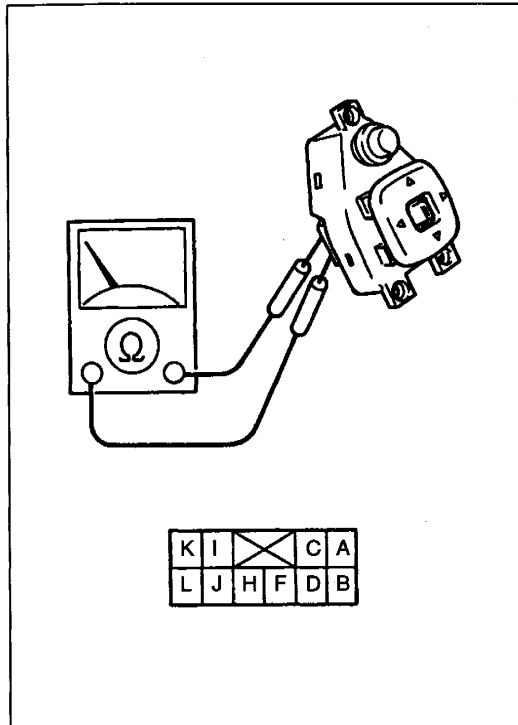
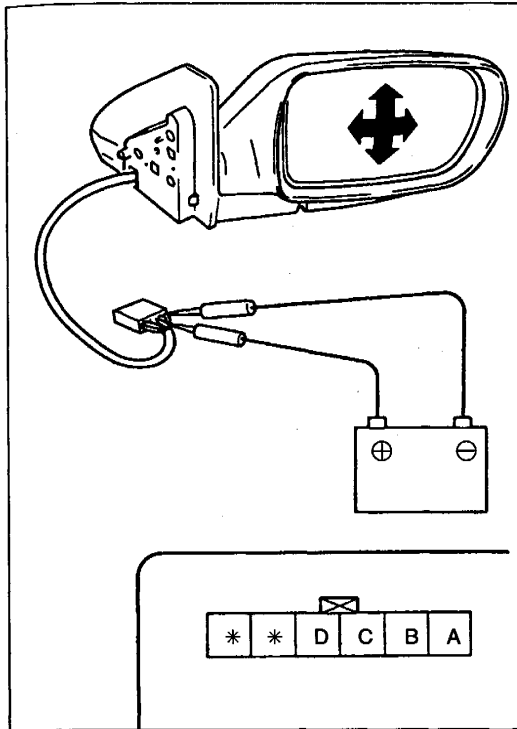

POWER OUTSIDE MIRROR

Inspection

1. Remove the power outside mirror.
(Refer to page S1-59.)
2. Apply battery positive voltage and check the operation of the power outside mirror.

B+: Battery positive voltage

Connection		Mirror operation
B+	GND	
A	B	Up
B	A	Down
B	C	Left
C	B	Right

3. If not as specified, replace the power outside mirror.

POWER OUTSIDE MIRROR SWITCH

Inspection

1. Remove the power outside mirror switch.
(Refer to page S1-59.)
2. Check for continuity between the switch terminals.

Switch position		Terminal						
		D	F	H	I	J	K	L
Left	UP	○	○	○	○			○
	DOWN	○	○	○	○			
	LEFT	○	○	○				○
	RIGHT	○	○	○	○			○
Right	UP	○	○	○	○	○	○	
	DOWN	○	○	○	○	○		
	LEFT	○	○	○		○	○	
	RIGHT	○	○	○	○	○	○	

○—○: Continuity

3. If not as specified, replace the power outside mirror switch.

REARVIEW MIRROR

PREPARATION

SST

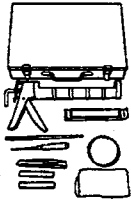
49 0305 870A Tool set, window		For removal / installation of base
---	---	---

REARVIEW MIRROR

Removal / Installation

1. Remove in the order shown in the figure, referring to **Removal note**.
2. Install in the reverse order of removal, referring to **Installation note**.

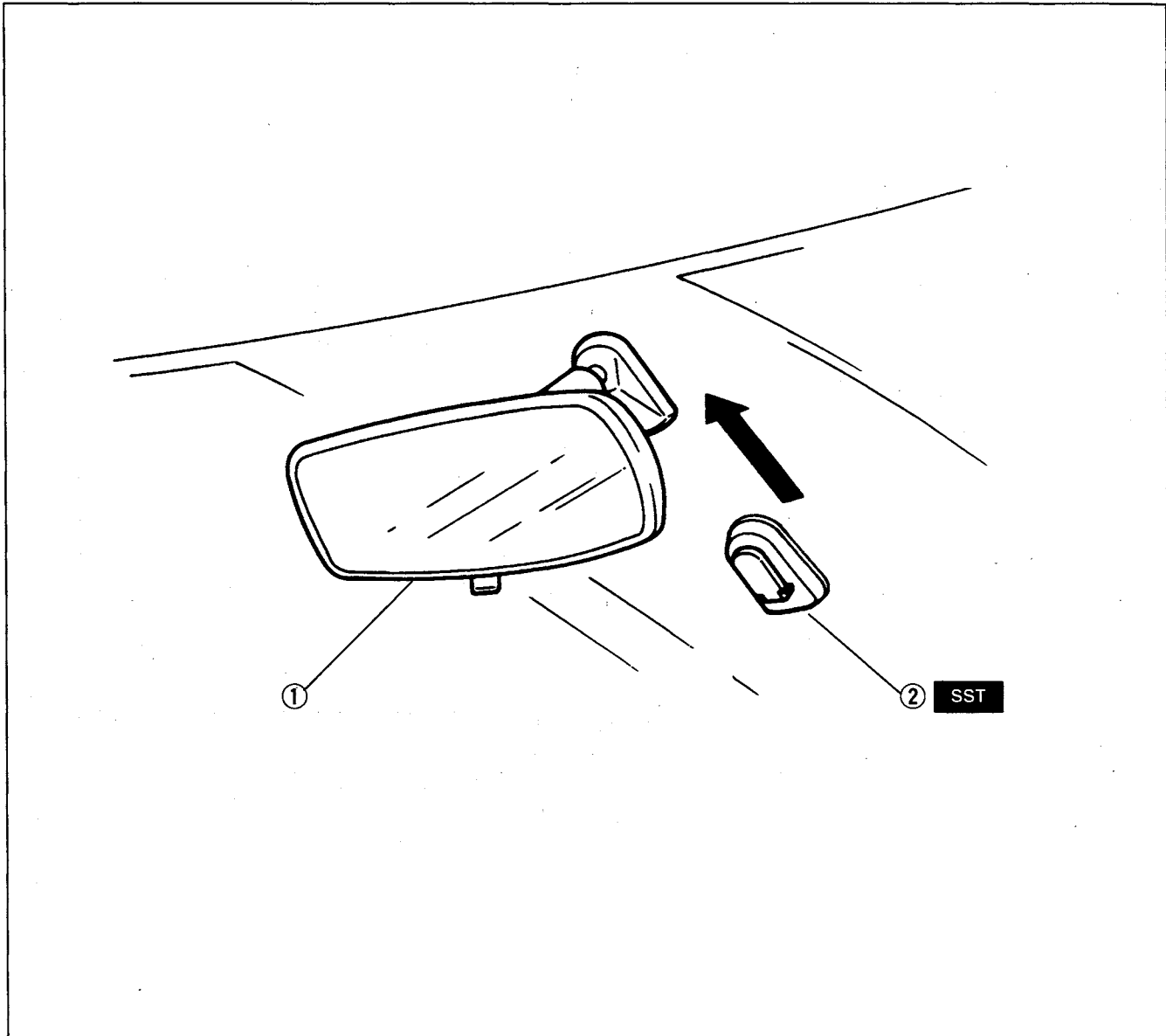

1. Rearview mirror
Removal note page S1-63

2. Base
Removal note page S1-63
Installation note page S1-63

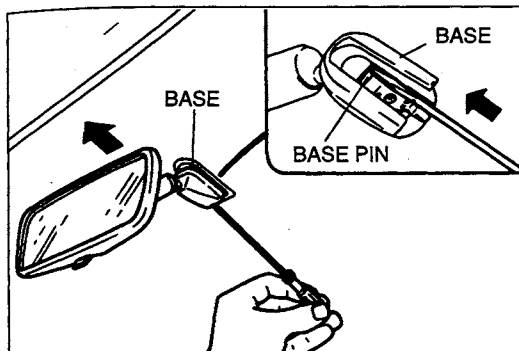

Removal note

Rearview mirror

1. Insert a flathead screwdriver between the mirror and the base.
2. Push the base pin to remove the mirror.

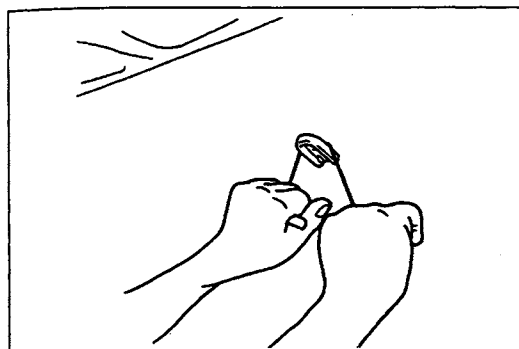

Base

1. Wind each end of a wire around a bar.
2. Saw through the sealant to remove the base. Use a long sawing action to spread the work over the whole length of wire to prevent it from breaking.

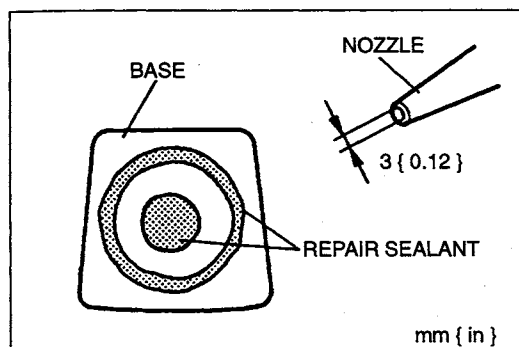

Installation note

Base

1. Cut away all of the original sealant by using a razor knife.
2. Clean and degrease the glass.
3. Apply primer to the glass and the base. Use only glass primer on the glass and body primer on the base. Keep the bonding area free of dirt and grease, and do not touch the surface. Allow the primer to dry for approximately **30 minutes**.
4. Apply a **3 mm { 0.12 in }** bead of repair sealant to the base.
5. Center the base in the ceramic coating and press it onto the glass. Use ethyl alcohol to remove any excess repair sealant.

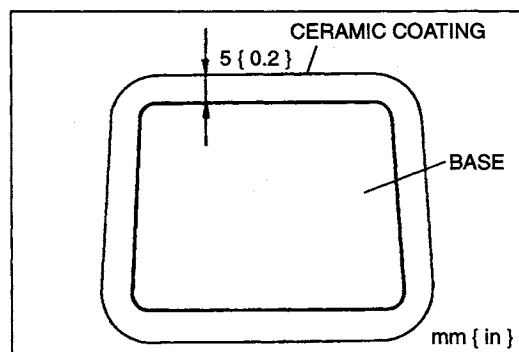

Hardening time of repair sealant

Temperature	Surface hardening time	Time required until car can be put into service
5 °C { 41 °F }	Approx. 1.5 hr	12 hr
20 °C { 68 °F }	Approx. 1 hr	4 hr
35 °C { 95 °F }	Approx. 10 min	2 hr

REAR WINDOW DEFROSTER

STRUCTURAL VIEW

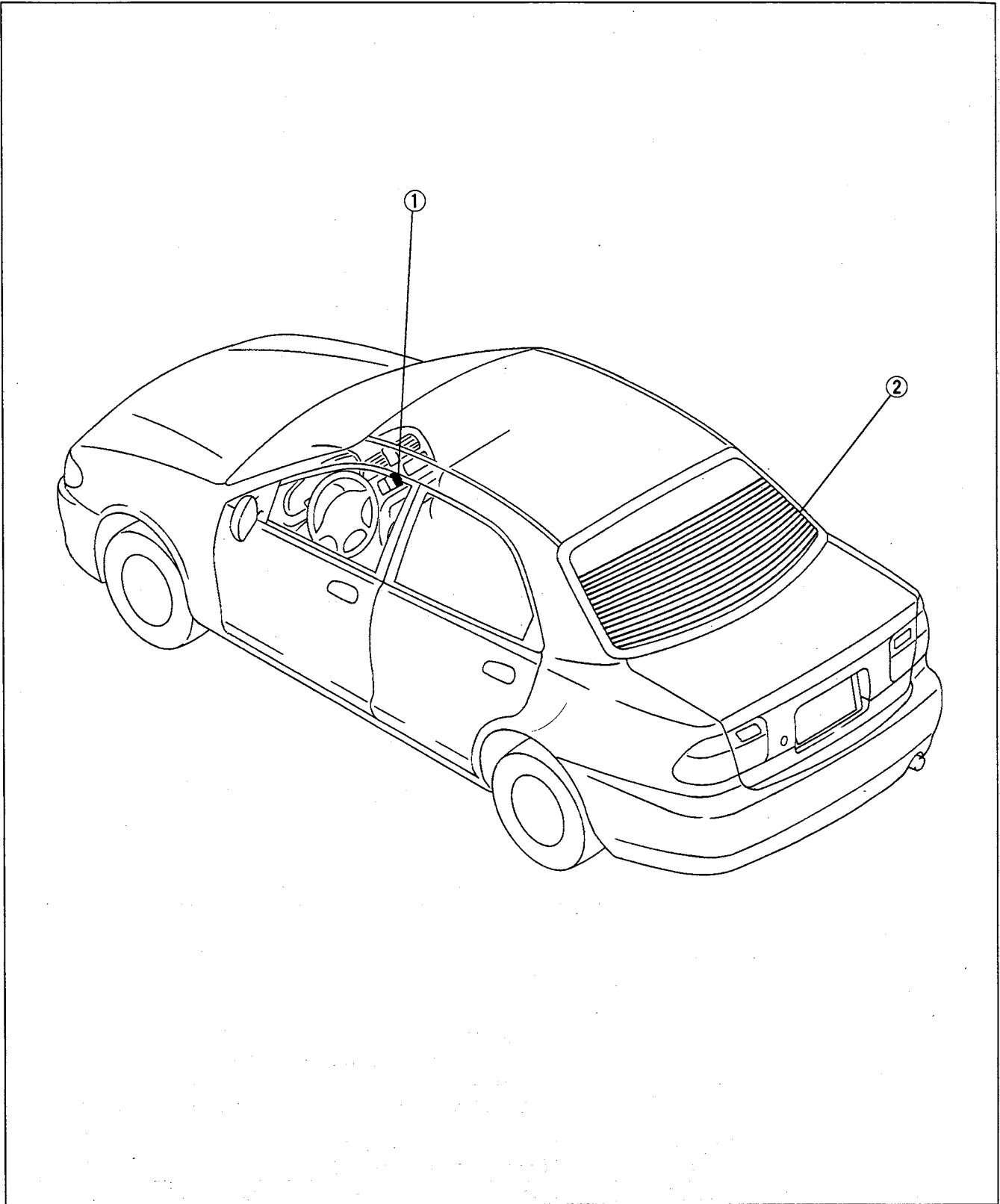

- 1. Rear window defroster switch
 - Removal / Installation page S1-65
 - Inspection page S1-65

- 2. Filament
 - Inspection page S1-66
 - Repair page S1-66

REAR WINDOW DEFROSTER SWITCH

Removal / Installation

1. Disconnect the negative battery cable.
2. Remove the meter hood. (Refer to page S1-96.)
3. Remove as shown in the figure.
4. Install in the reverse order of removal.

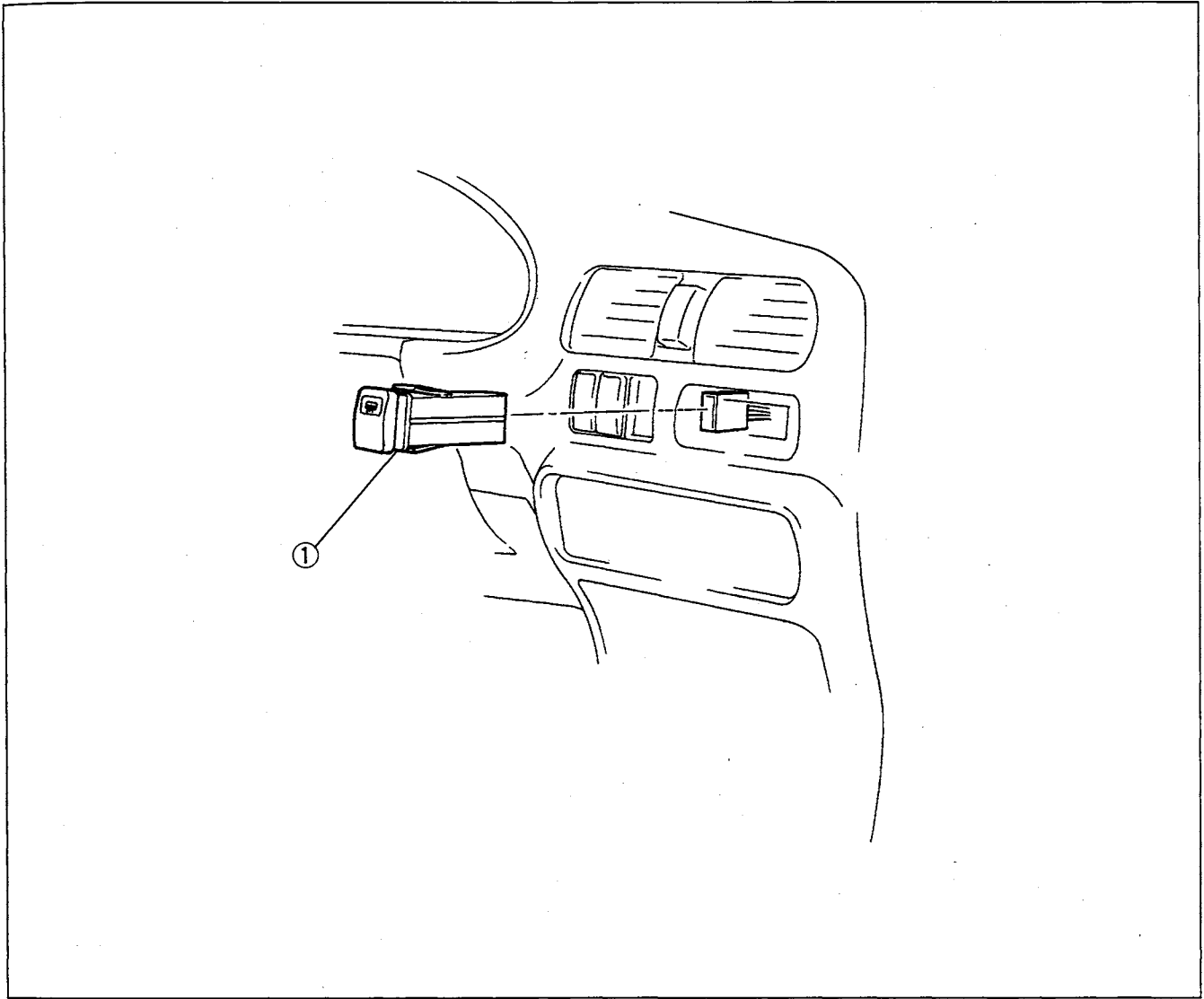

1. Rear window defroster switch
 Inspection below

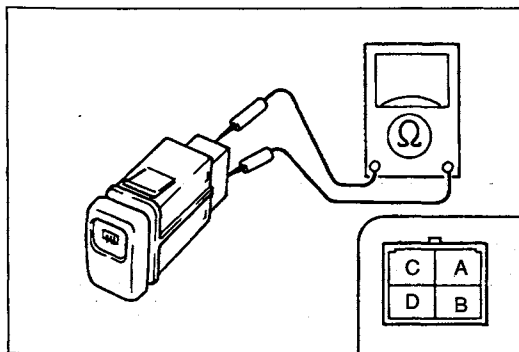

Inspection

1. Remove the rear window defroster switch.
 (Refer above.)
2. Check for continuity between the switch terminals.

Terminal	B	D
Switch position		
ON	○ — ○	○ — ○
OFF		

○ — ○: Continuity

3. If not as specified, replace the rear window defroster switch.

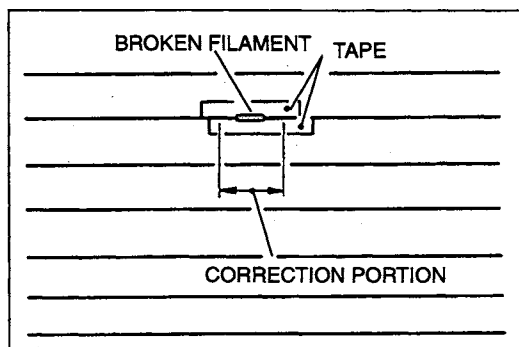
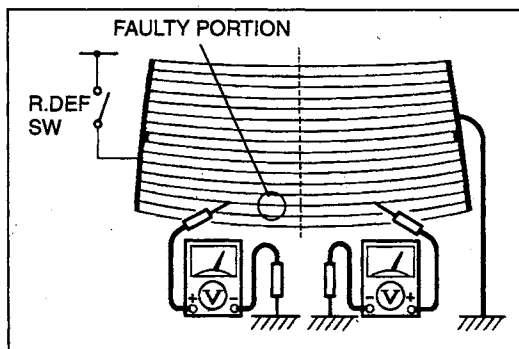
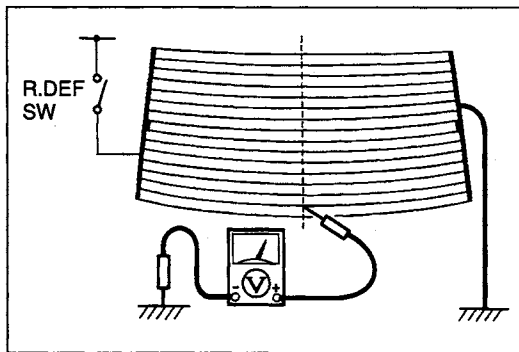

FILAMENT Inspection

1. Turn the rear window defroster switch on.
2. Connect the (+) terminal of a voltmeter to the center of each filament and the (-) terminal to the body and check the voltage.

Standard voltage: 5—7 V

Note

- If the meter indication is high, there is an open circuit between the center and the ground side of the filament.
 - If the meter indication is low or zero, the malfunction is between the center and positive side of the filament.
3. If not as specified, repair the filament. (Refer below.)

Repair

Caution

- Use only paint thinner or ethyl alcohol for cleaning. Other solvents can damage the surrounding filament.
1. Use paint thinner or ethyl alcohol to clean around the damaged section of the filament.
 2. Attach tape above and below the damaged section of the filament.
 3. Using a small brush or marking pen, repair the filament with silver paint or equivalent.
 4. Use a hot-air blower heated to **150 °C { 302 °F }** for **30 minutes** or let the paint set for **24 hours** at **25 °C { 77 °F }** to allow it to dry completely. Do not use the defroster until the paint is dry.

WINDOW GLASS

**PREPARATION
SST**

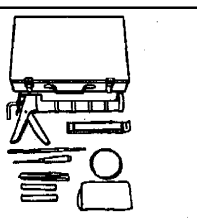
<p>49 0305 870A</p> <p>Tool set, window</p>		<p>For removal / installation of glass</p>
---	---	--

WINDSHIELD

Removal

1. Remove the following parts.
 - a. Headliner (Refer to page S1-116.)
 - b. Rearview mirror (Refer to page S1-62.)
 - c. Cowl grille (Refer to page S1-58.)
 - d. Windshield molding (Refer to page S1-49.)
 - e. Glass stopper (Refer to page S1-57.)
2. Remove in the order shown in the figure, referring to **Removal note**.

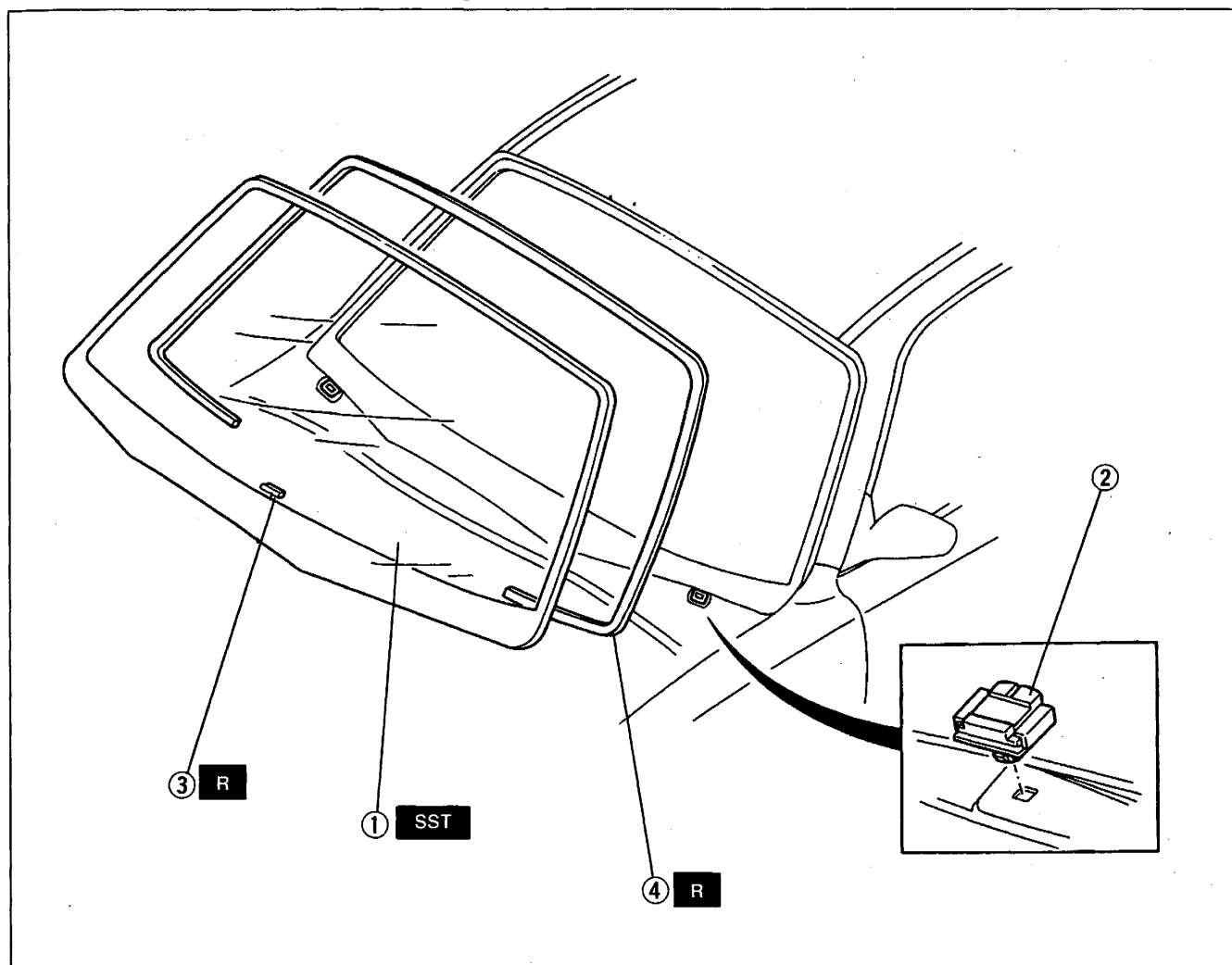

- | | | |
|-------------------------------------|------------|-------------|
| 1. Windshield
Removal note | page S1-68 | 3. Spacer B |
| 2. Spacer A | | 4. Dam |

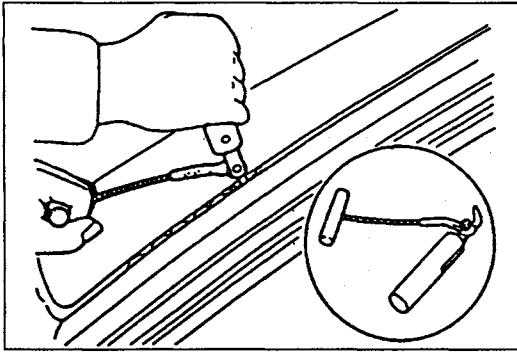

Removal note
Windshield

1. Apply protective tape along the edge of the body to protect it from damage.

If the glass will not be reused

2. Use a tool like that shown in the figure and insert the blade into the sealant.
3. Pull it through the sealant around the edge of the glass.
4. Remove the glass.

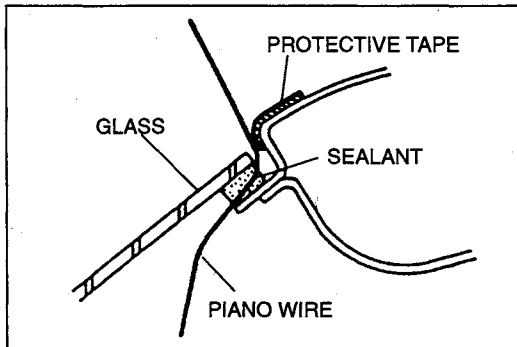

If the glass will be reused

2. Make a hole through the sealant from the inside of the vehicle by using an awl.
3. Pass piano wire through the hole.

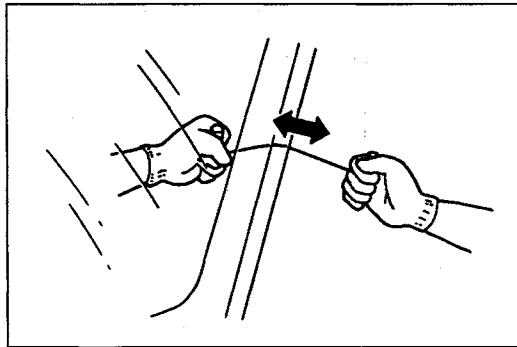

4. Wind each end of the wire around a bar.
5. Working with another person, saw through the sealant around the edge of the glass. Use a long sawing action to spread the work over the whole length of wire to prevent it from breaking. Make sure the wire does not rub on the body or the dashboard.
6. Remove the glass.

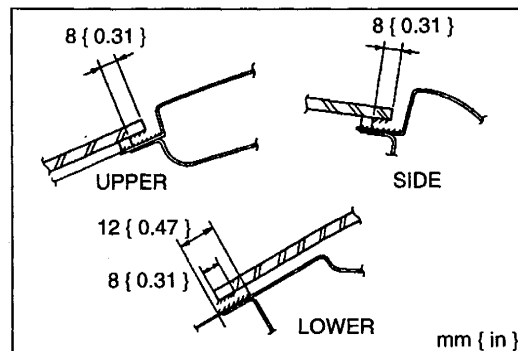
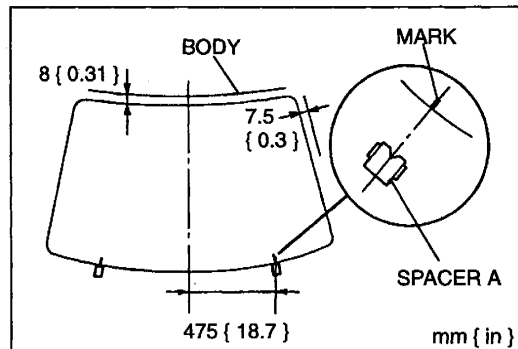
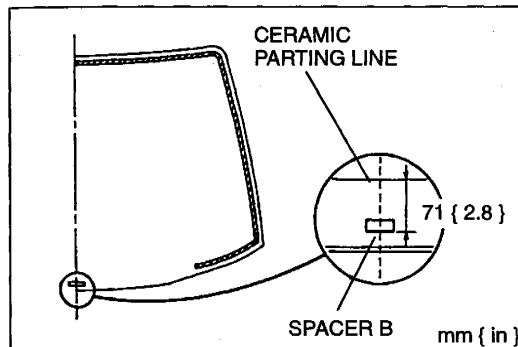
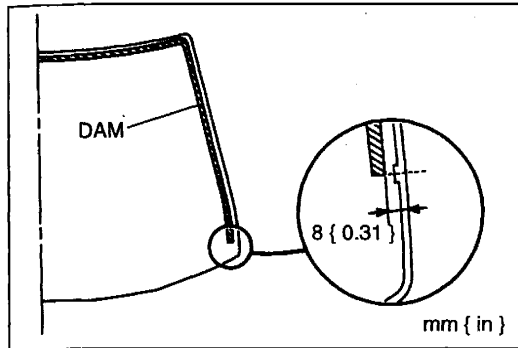
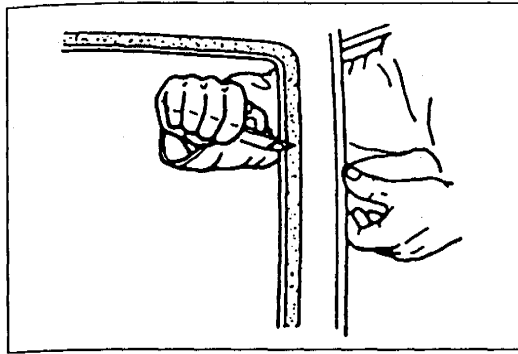

Installation

1. Cut away the old sealant by using a razor knife so that **1 to 2 mm { 0.04 to 0.08 in }** of sealant remains around the circumference of the frame. If all the sealant has come off in any one place, apply some primer after degreasing, and allow it **30 minutes** to dry. Then apply new sealant to create a **2 mm { 0.08 in }** layer.
2. Carefully clean an area **50 mm { 2.0 in }** wide around the circumference of the glass and clean the bonding area on the body.
3. Securely bond a new dam **8 mm { 0.31 in }** from the edge of the glass as shown. Allow it to dry completely.
4. Securely bond spacer B to the glass as shown.
5. Install spacers A. If a spacer is damaged, replace it.
6. Temporarily install the glass onto the body and adjust the glass-to-body clearance.
7. Make a mark on the glass directly above the V-notch of spacers A.
8. Remove the glass.
9. Apply primer to the bonding area of the glass and body by using a brush. Use only glass primer on the glass and body primer on the body. Keep the area free of dirt and grease, and do not touch the surface. Allow it to dry for approximately **30 minutes**.

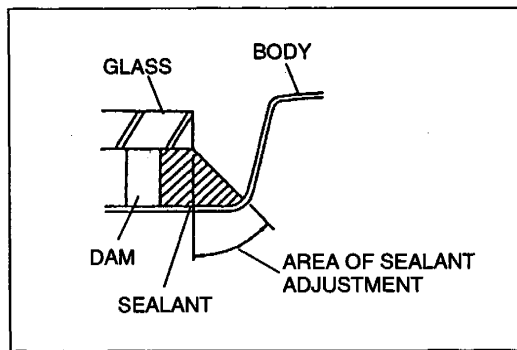
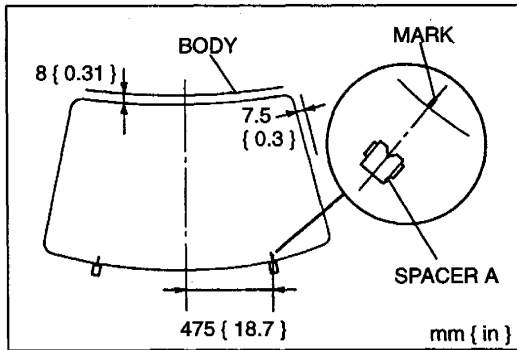
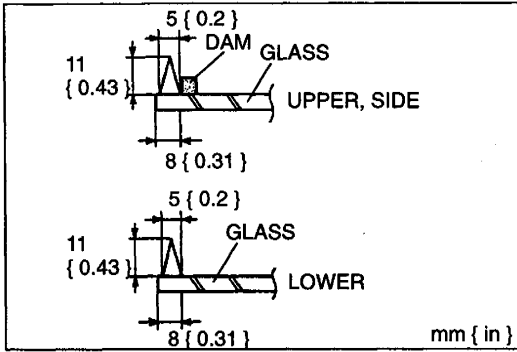

10. Apply an 11 mm { 0.43 in } high bead of repair sealant around the circumference of the glass as shown. Keep the bead of sealant smooth and even, reshaping it with a spatula where necessary. If the windshield is being reused, apply new repair sealant over the original.

11. Align the glass marks with the V-notches of spacers A and install the glass onto the body.
12. Press firmly on the glass to compress the sealant. Verify that the body-to-glass clearance is as shown.

13. Use a scraper to smooth away any sealant that oozes out. Add more sealant to any points of poor contact. Adjust the upper and side sealant as shown, if necessary.
14. To prevent the glass from being pushed out by air pressure if a door is closed, open all of the windows until the repair sealant has hardened.

Hardening time of repair sealant

Temperature	Surface hardening time	Time required until car can be put into service
5 °C { 41 °F }	Approx. 1.5 hr	12 hr
20 °C { 68 °F }	Approx. 1 hr	4 hr
35 °C { 95 °F }	Approx. 10 min	2 hr

15. Check for water leaks. If a leak is found, wipe the water off well and reinstall the windshield.
16. Install the following parts.
 - a. Glass stopper (Refer to page S1-57.)
 - b. Windshield molding (Refer to page S1-49.)
 - c. Cowl grille (Refer to page S1-58.)
 - d. Rearview mirror (Refer to page S1-62.)
 - e. Headliner (Refer to page S1-116.)

REAR WINDOW GLASS

Removal

1. Remove the following parts.
 - a. Headliner (Refer to page S1-116.)
 - b. Rear package trim (Refer to page S1-109.)
2. Remove in the order shown in the figure, referring to **Removal note**.

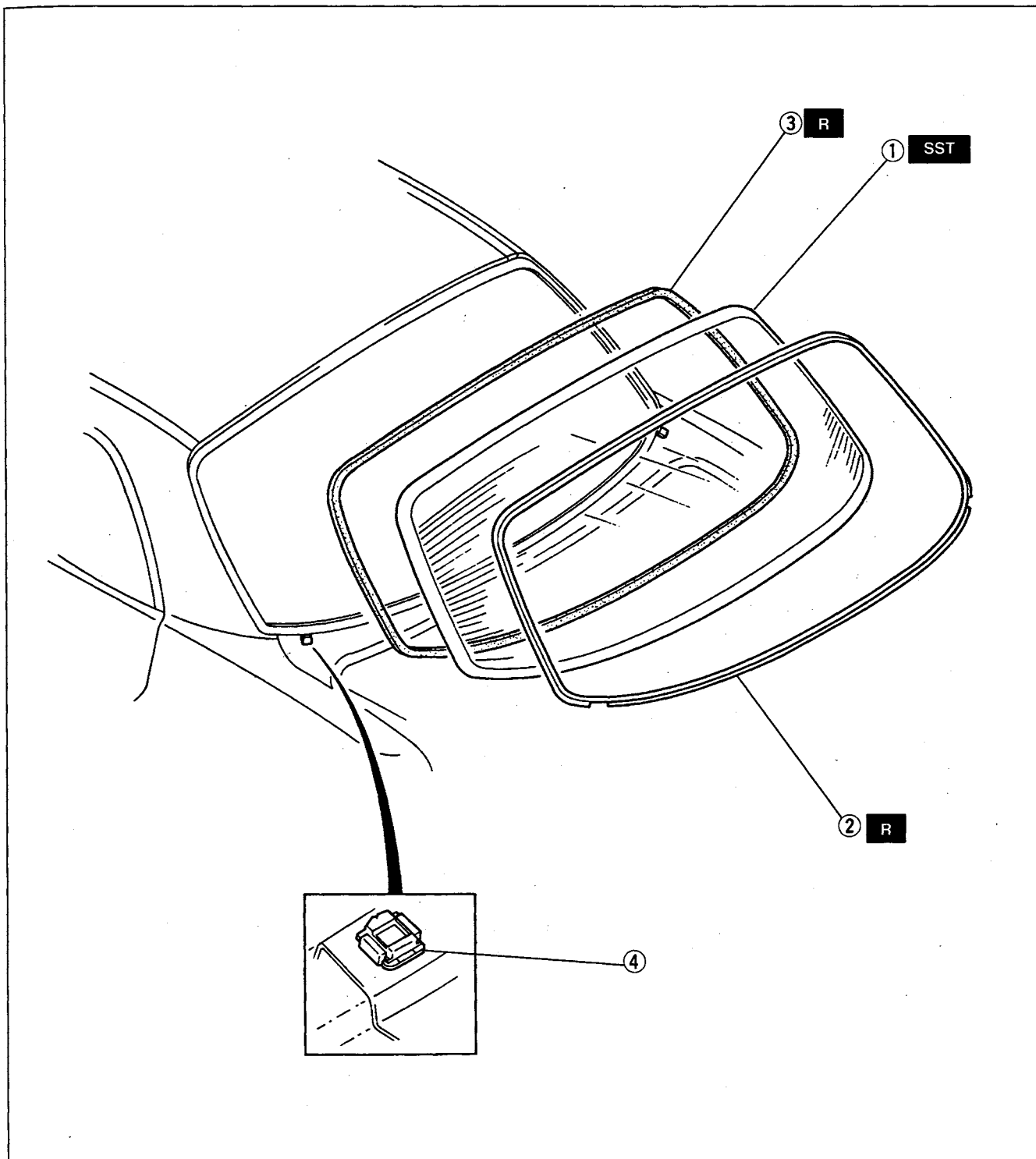

- | | |
|-------------------------------|-----------|
| 1. Rear window glass | 3. Dam |
| Removal note page S1-72 | 4. Spacer |
| 2. Rear window molding | |

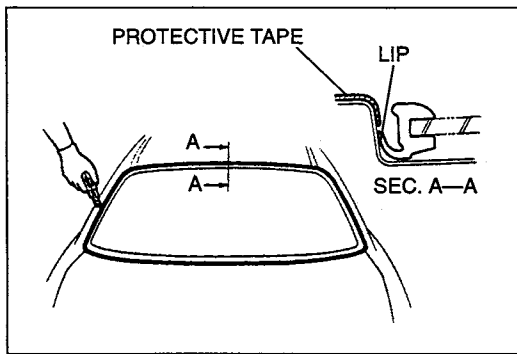
**Removal note****Rear window glass**

1. Apply protective tape along the edge of the body to protect it from damage.
2. Cut the lip of the rear window molding by using a razor knife and remove the lip.

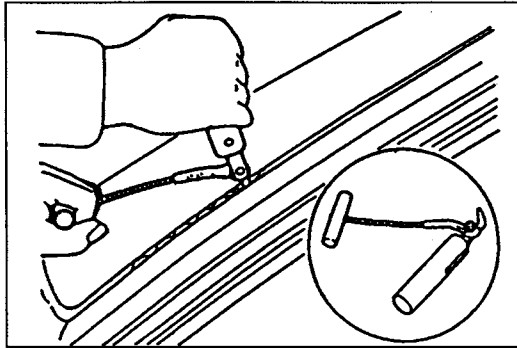
**If the glass will not be reused**

3. Use a tool like that shown in the figure and insert the blade into the sealant.
4. Pull it through the sealant around the edge of the glass.
5. Remove the glass.

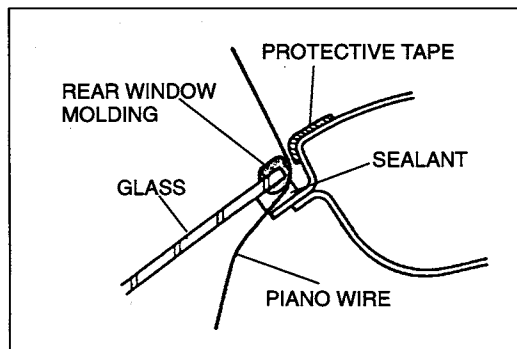
**If the glass will be reused**

3. Make a hole through the sealant from the inside of the vehicle by using an awl.
4. Pass piano wire through the hole.

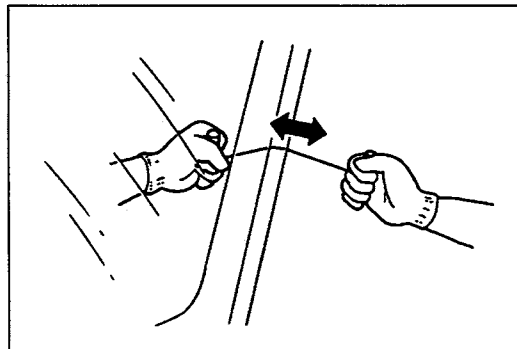

5. Wind each end of the wire around a bar.
6. Working with another person, saw through the sealant around the edge of the glass. Use a long sawing action to spread the work over the whole length of wire to prevent it from breaking. Make sure the wire does not rub on the body.
7. Remove the glass.

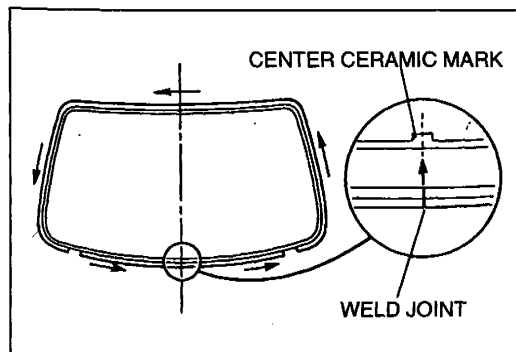
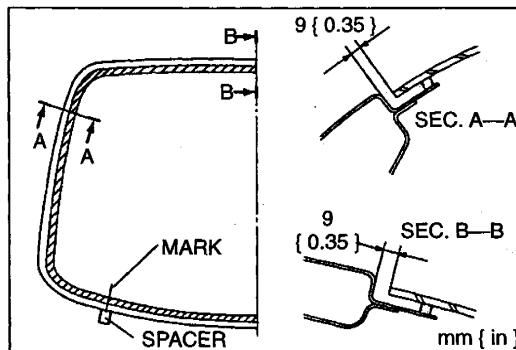
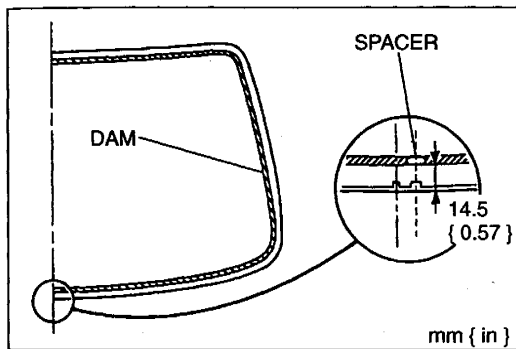
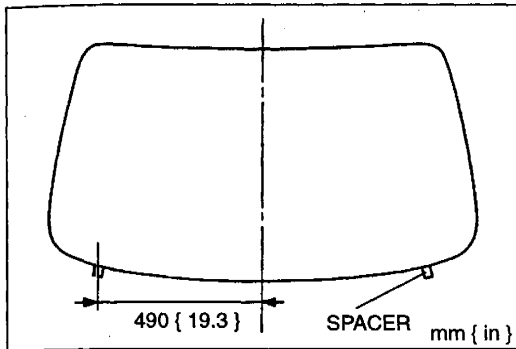
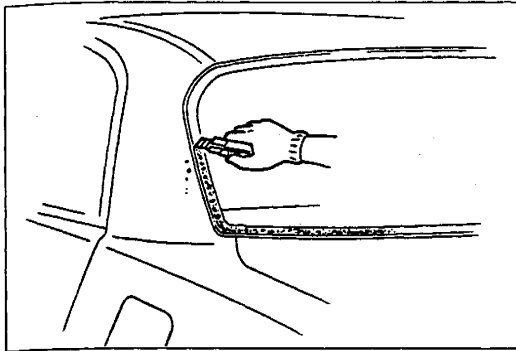

Installation

1. Cut away the old sealant by using a razor knife so that **1 to 2 mm { 0.04 to 0.08 in }** of sealant remains around the circumference of the frame. If all the sealant has come off in any one place, apply some primer after degreasing, and allow it **30 minutes** to dry. Then apply new sealant to create a **2 mm { 0.08 in }** layer.
2. Carefully clean an area **50 mm { 2.0 in }** wide around the circumference of the glass and clean the bonding area on the body.

3. Install the spacers onto the body.

4. Install the spacer part of the dam as shown and securely bond the dam around the circumference of the glass **14.5 mm { 0.57 in }** from the edge. Allow the dam to dry completely.

5. Temporarily install the glass onto the body and adjust the glass-to-body clearance.
6. Make a mark on the glass directly above the V-notch of the spacers.
7. Remove the glass.

8. Install the rear window molding to the glass.
 - (1) Align the weld joint of the molding with the center ceramic mark on the glass.
 - (2) Attach the molding in the direction shown in the figure.

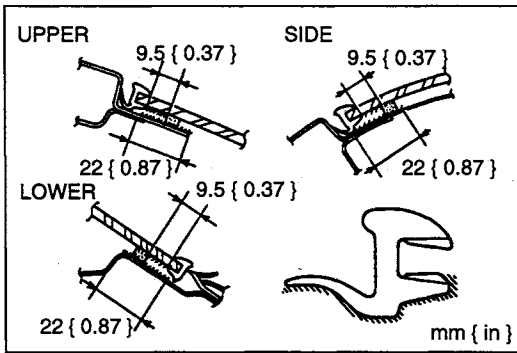

9. Apply primer to the bonding area of the molding, glass, and body by using a brush. Use only glass primer on the glass and body primer on the body and molding. Keep the area free of dirt and grease, and do not touch the surface. Allow it to dry for approximately **30 minutes**.

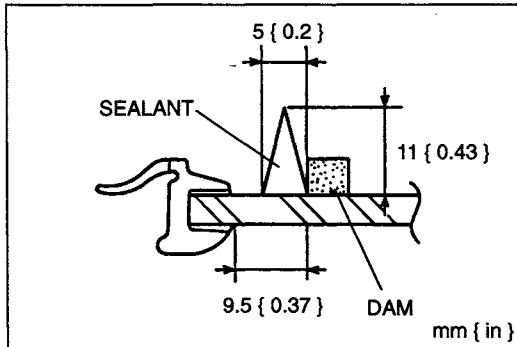

10. Apply an **11 mm { 0.43 in }** high bead of repair sealant around the circumference of the glass as shown. Keep the bead of sealant smooth and even, reshaping it with a spatula where necessary. If the rear window glass is being reused, apply new repair sealant over the original.

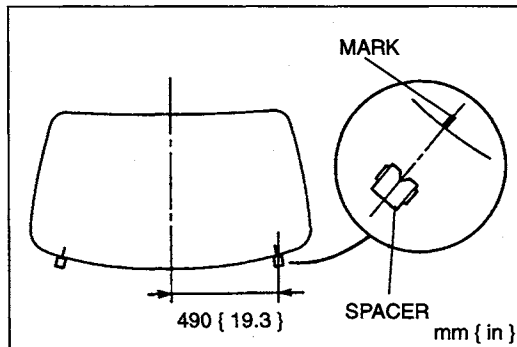

11. Align the glass marks with the V-notches of the spacers and install the glass onto the body.
12. Press firmly on the glass to compress the sealant.
13. To prevent the glass from being pushed out by air pressure if a door is closed, open all of the windows until the repair sealant has hardened.

Hardening time of repair sealant

Temperature	Surface hardening time	Time required until car can be put into service
5 °C { 41 °F }	Approx. 1.5 hr	12 hr
20 °C { 68 °F }	Approx. 1 hr	4 hr
35 °C { 95 °F }	Approx. 10 min	2 hr

14. Check for water leaks. If a leak is found, wipe the water off well and reinstall the rear window glass.
15. Install the following parts.
 - a. Rear package trim (Refer to page S1-109.)
 - b. Headliner (Refer to page S1-116.)

SLIDING SUNROOF

SLIDING SUNROOF
Removal / Installation

1. Disconnect the negative battery cable.
2. Remove in the order shown in the figure, referring to **Removal note**. To remove the sunroof motor, remove the headliner. (Refer to page S1-116.)
3. Install in the reverse order of removal, referring to **Installation note**.

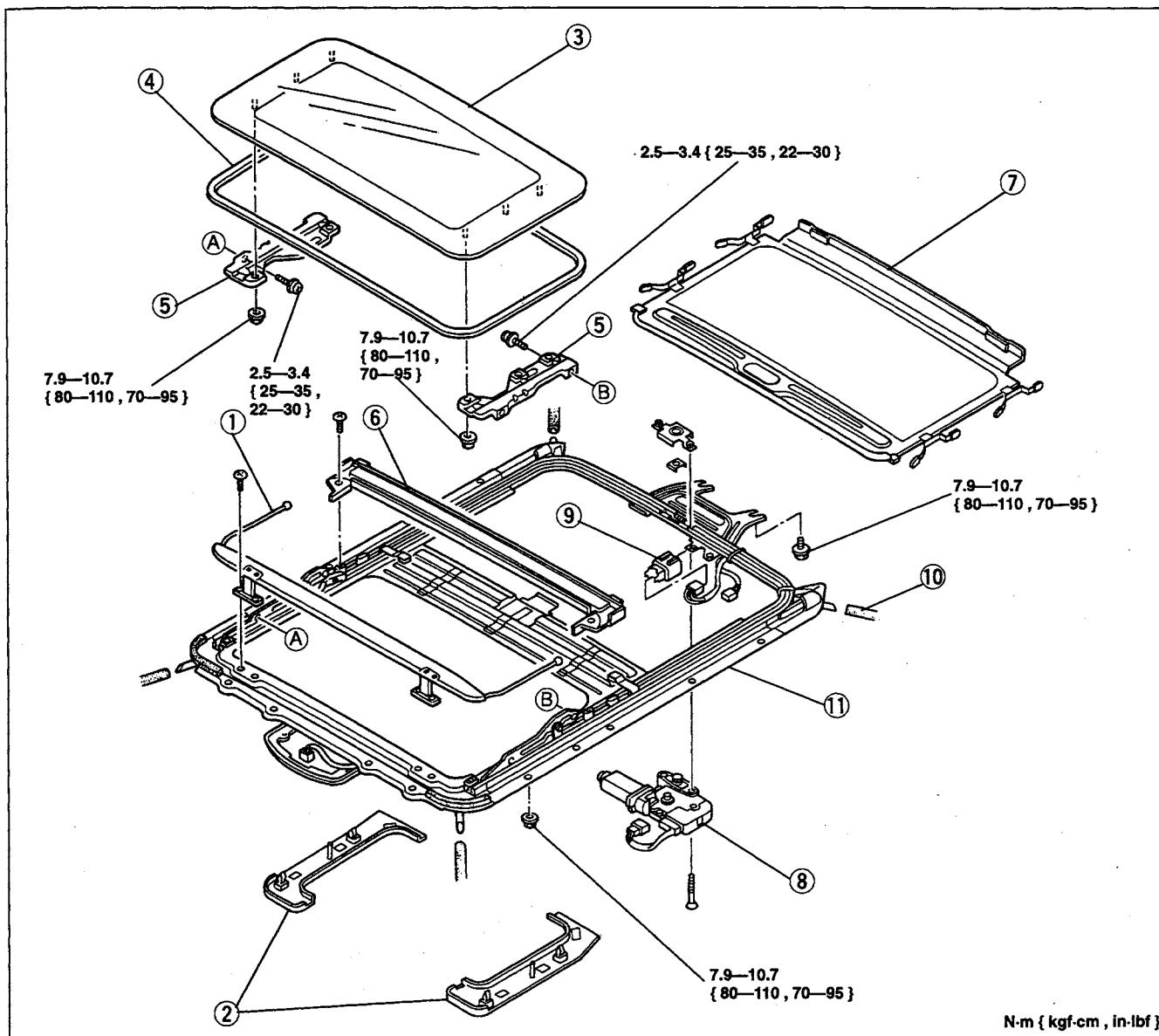

- 1. Deflector
Removal note page S1-76
- 2. Lower panel cover
Removal note page S1-76
- 3. Glass panel
Removal note page S1-76
Adjustment page S1-80
- 4. Weatherstrip
- 5. Lower panel
- 6. Drip rail
- 7. Sunshade
Removal note page S1-76

- 8. Sunroof motor
Installation note page S1-77
Inspection page S1-81
- 9. Sunroof relay
Inspection page S1-81
- 10. Drain hose
Installation note page S1-77
- 11. Sunroof drive unit
Removal note page S1-77
Disassembly / Assembly page S1-78

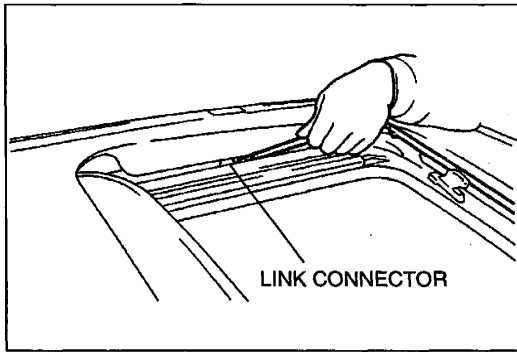
**Removal note****Deflector**

1. Open the glass panel.
2. Remove the link from the link connector.
3. Remove the installation screws and remove the deflector from the frame.

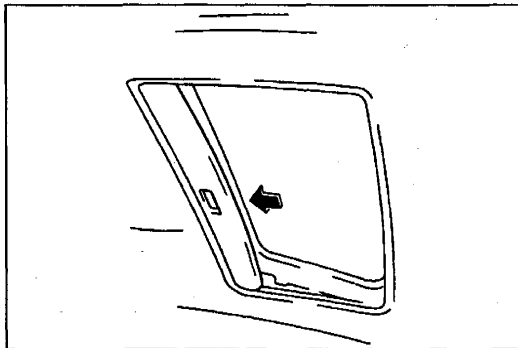
**Lower panel cover**

1. Open the sunshade fully.
2. Close the glass panel.

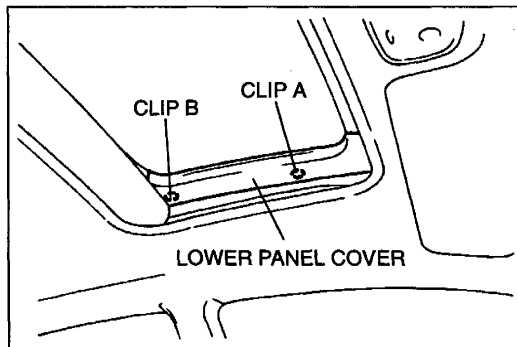

3. Pull the lower panel cover downward to disengage clips A from the body.
4. Slide the lower panel cover inside to disengage clips B from the body.

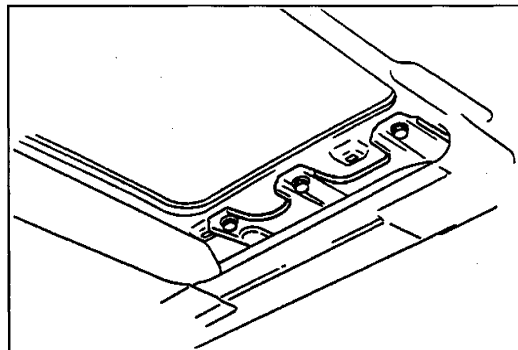
**Glass panel**

Close the glass panel to remove the installation nuts.

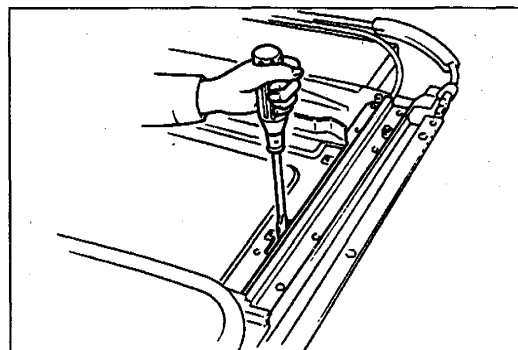
**Sunshade**

Remove the sunshade pins from the groove in the frame by using a flathead screwdriver which has been wrapped in tape.

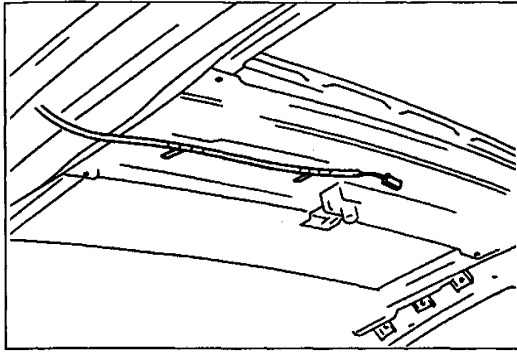
**Sunroof drive unit**

Remove the room light harness.

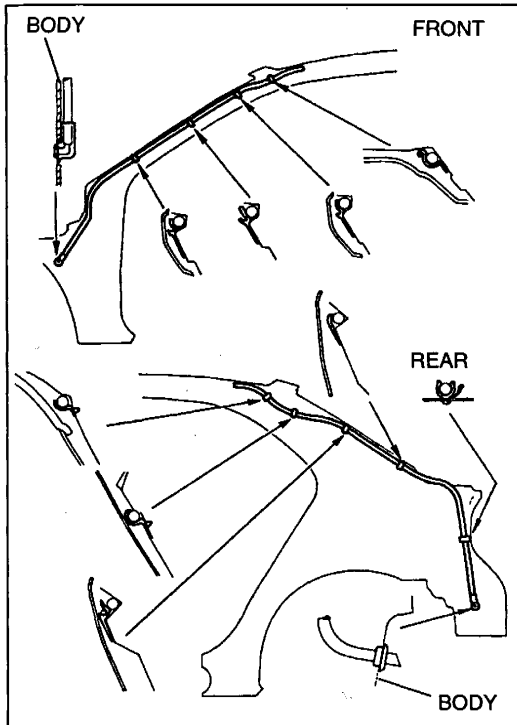
**Installation note****Drain hose****Note**

- Apply soapy water to the drain hose and insert it fully into the sunroof frame.

(front)

Insert one end of the hose into the sunroof frame, set the hose along the A-pillar, and insert the other end into the hinge pillar inner hole.

(rear)

Insert one end of the hose into the sunroof frame, set the hose along the rear pillar, and insert the other end into the side frame outer hole.

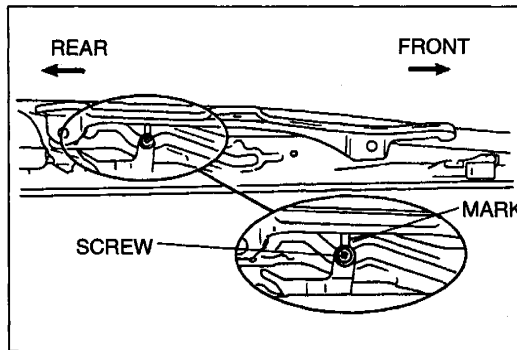
**Sunroof motor**

1. Move the guide by hand until the screw is aligned with the mark.

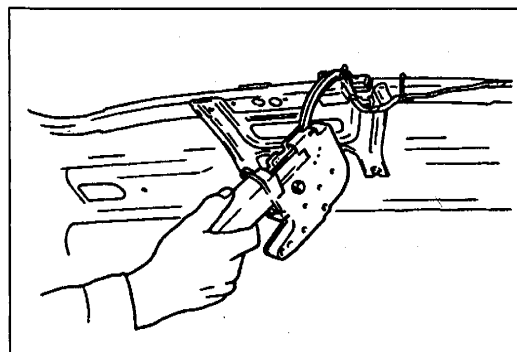

2. Connect the harness connector to the sunroof motor and overhead console.
3. Press the OPEN side of the slide switch until the motor stops. Then press the CLOSE side of the slide switch until the motor stops.
4. Install the motor to the frame.

Disassembly / Assembly

1. Disassemble in the order shown in the figure, referring to **Disassembly note**.
2. Assemble in the reverse order of disassembly, referring to **Assembly note**.

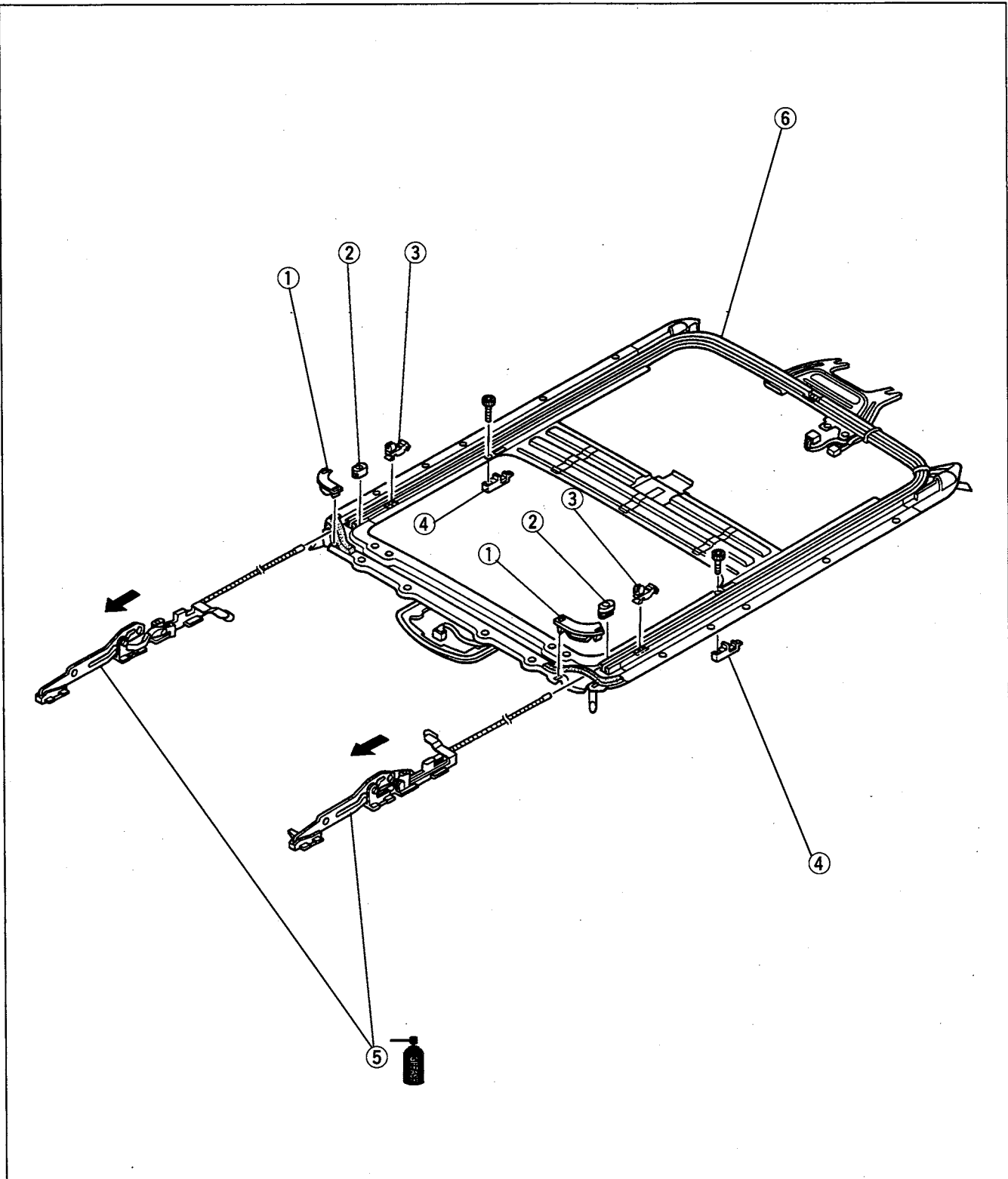

- 1. Rail cover
- 2. Guide stopper
- 3. Deflector pin
Disassembly note page S1-79
- 4. Rear guide stopper

- 5. Drive unit
Disassembly note page S1-79
Assembly note page S1-79
- 6. Frame

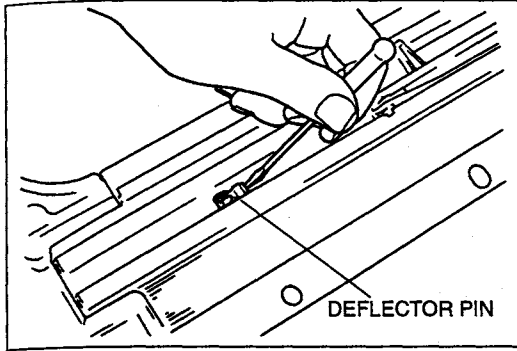
**Disassembly note****Deflector pin**

Lift the deflector pin by using a flathead screwdriver to remove the pin.

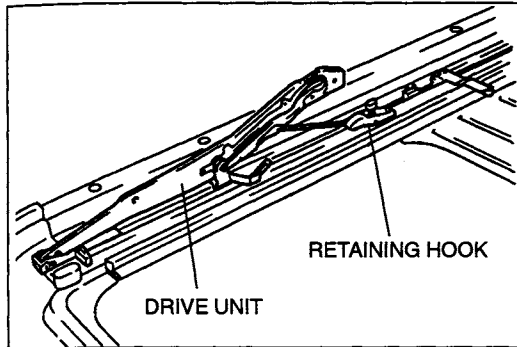
**Drive unit**

Push the front of the retaining hook to disengage it from the frame, and then pull the drive unit to remove it.

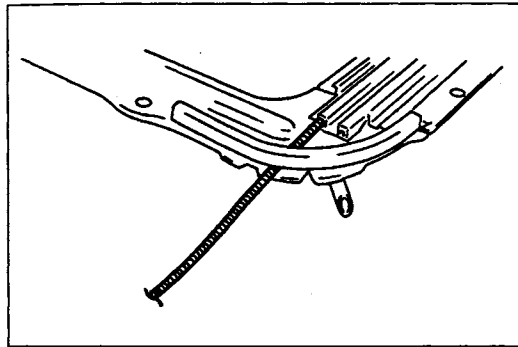
**Assembly note****Drive unit**

1. Grease the contact area of the drive unit.
2. Insert the cable into the channel of the guide rail.

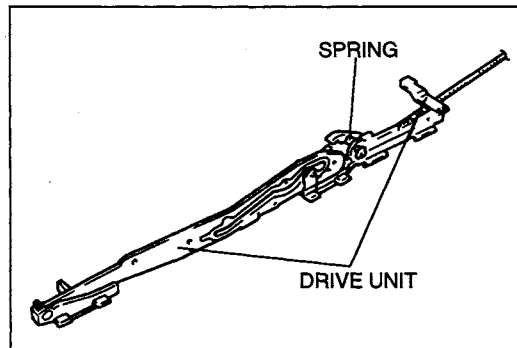

3. Verify that the spring is onto the retaining hook when the drive unit is inserted into the guide rail.

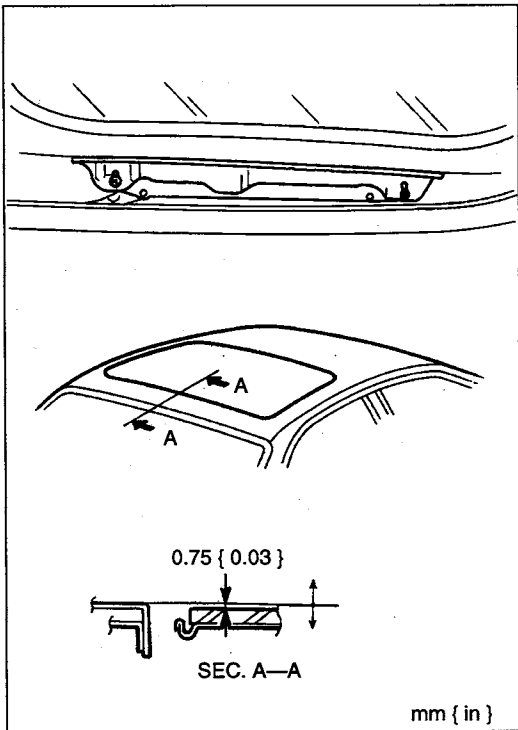

Adjustment Glass panel Height

1. Remove the lower panel cover. (Refer to page S1-75.)
2. Pull up on the weatherstrip surrounding the section which is to be measured.
3. Loosen the lower panel installation screw and adjust the height.

Allowable height clearance: $0^{+0.5}_{-1.5}$ mm { $0^{+0.02}_{-0.06}$ in }

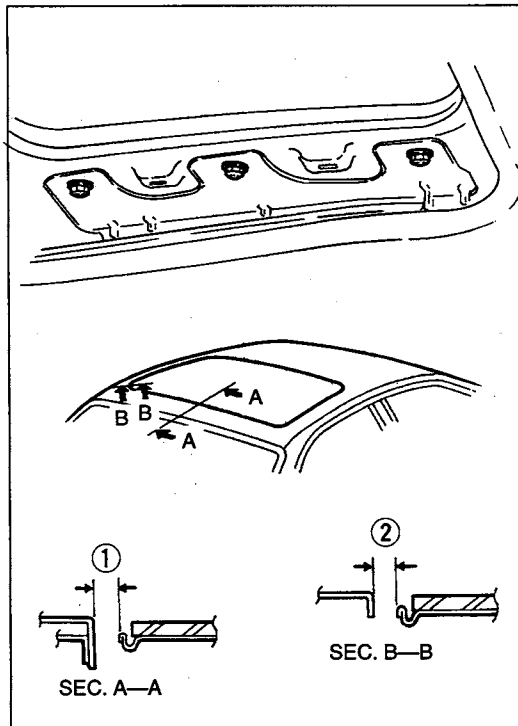

Gap

1. Open the glass panel about 100 mm { 3.9 in } from the fully closed position.
2. Pull up on the weatherstrip surrounding the section which is to be measured.
3. Fully closed the glass panel.
4. Remove the lower panel cover. (Refer to page S1-75.)
5. Loosen the glass panel installation nuts and adjust the gap.
6. Open the glass panel and install the weatherstrip.

Allowable gap clearance

- ①: 6.80 ± 0.35 mm { 0.27 ± 0.01 in }
 ②: 6.60 ± 0.40 mm { 0.26 ± 0.02 in }

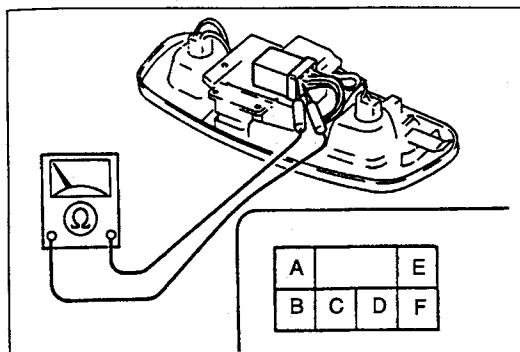

SUNROOF SWITCH

Inspection

1. Remove the overhead console. (Refer to page S1-116.)
2. Check for continuity between the terminals of the connector with the sunroof switch in the following positions.

Switch position	Terminal					
	A	B	C	D	E	F
Tilt-up	○	—	—	○		
Tilt-down	○	—	—	—	—	○
Slide open	○	○				
Slide close	○	—	○			

○—○: Continuity

3. If not as specified, replace the sunroof switch.

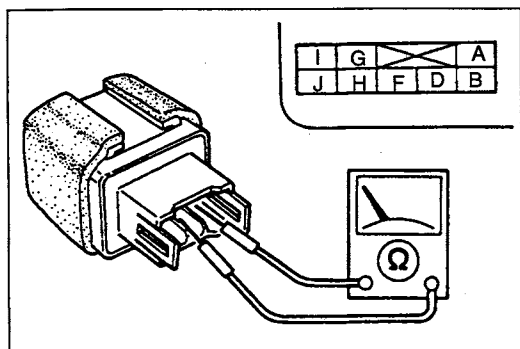

SUNROOF RELAY

Inspection

1. Remove the sunroof relay. (Refer to page S1-75.)
2. Apply battery positive voltage and check for continuity between the relay terminals.

B+: Battery positive voltage

Connection		A	B	D	G	H	I	J
B+	GND							
—	—	○	○	○	—	○	○	○
H	J				○	—	○	
H	B	○	—	—	○			

○—○: Continuity

3. If not as specified, replace the sunroof relay.

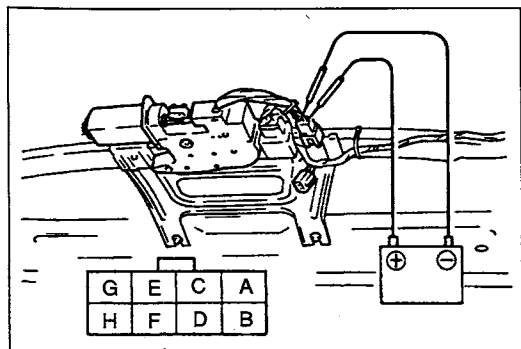

SUNROOF MOTOR

Inspection

Motor

1. Remove the headliner. (Refer to page S1-116.)
2. Disconnect the sunroof motor connector.
3. Apply battery positive voltage to terminal G and connect terminal H to ground. Verify that the motor rotates in the opening/tilt-down direction.
4. Reverse the above connections and verify that the motor rotates in the closing / tilt-up direction.
5. If not as specified, replace the sunroof motor.

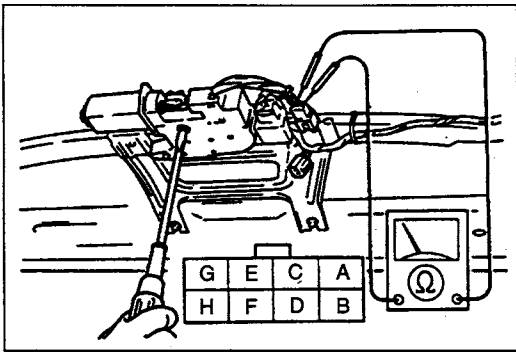

Limit switch

1. Remove the headliner. (Refer to page S1-116.)
2. Disconnect the sunroof motor connector.
3. Move the glass panel to the following positions by using a flathead screwdriver and check for continuity between the terminals of the sunroof motor connector.

Panel position \ Terminal	Terminal							
	A	B	C	D	E	F	G	H
Open				○	—	○		
Closed		○	—	○	—	○		
Tilted up	○	—			○			

○—○: Continuity

4. If not as specified, replace the sunroof motor.

DASHBOARD AND CONSOLE

STRUCTURAL VIEW

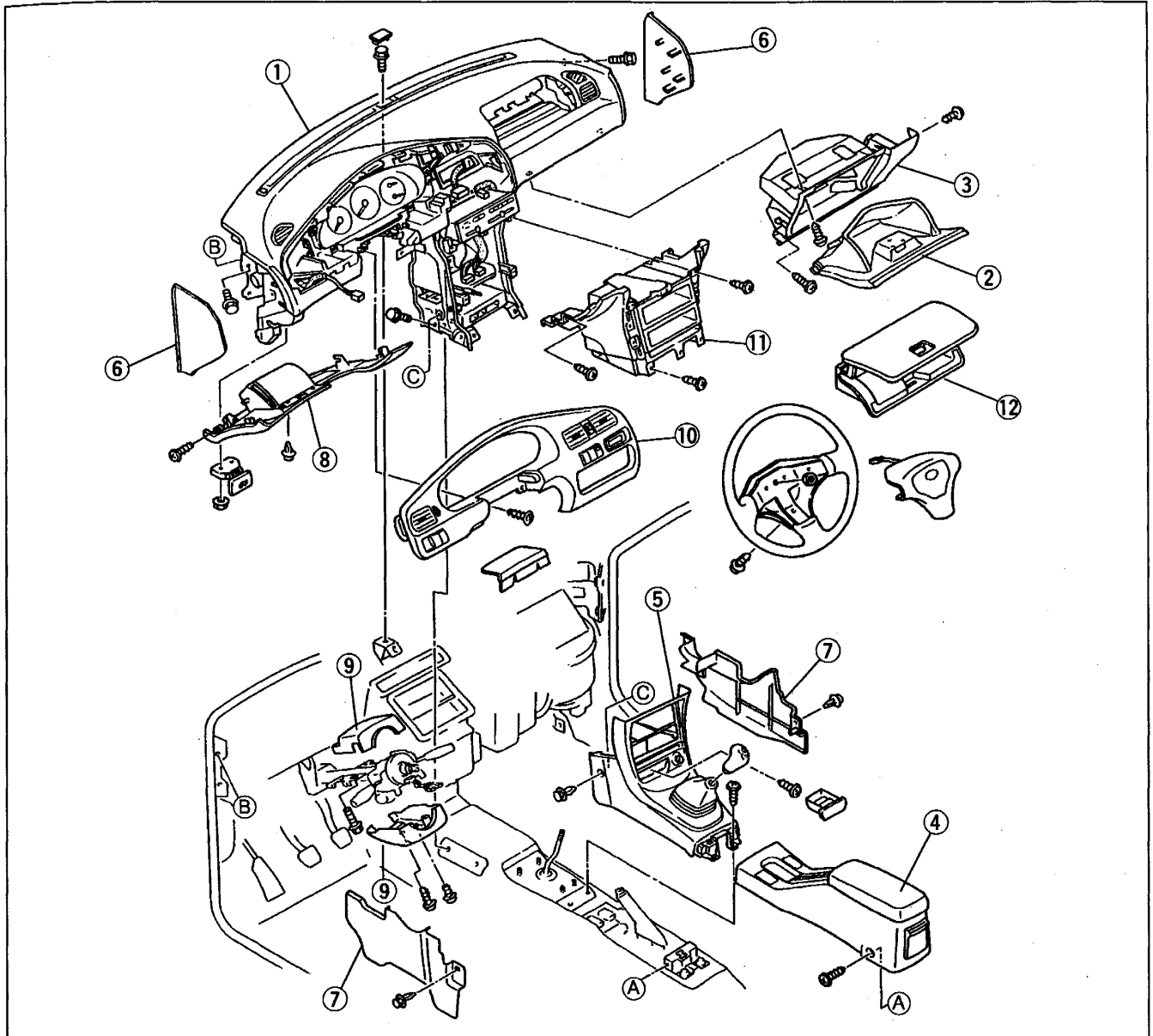

- | | |
|---|---|
| 1. Dashboard | 7. Side wall |
| Removal / Installation page S1-84 | Removal / Installation page S1-93 |
| Disassembly / Assembly page S1-86 | |
| 2. Glove compartment | 8. Lower panel |
| Removal / Installation page S1-87 | Removal / Installation page S1-94 |
| Disassembly / Assembly page S1-88 | |
| 3. Glove compartment cover | 9. Column cover |
| Removal / Installation page S1-88 | Removal / Installation page S1-95 |
| 4. Rear console | 10. Meter hood |
| Removal / Installation page S1-89 | Removal / Installation page S1-96 |
| Disassembly / Assembly page S1-89 | Disassembly / Assembly page S1-97 |
| 5. Front console | 11. Center lower panel |
| Removal / Installation page S1-90 | Removal / Installation page S1-97 |
| Disassembly / Assembly page S1-91 | |
| 6. Side panel | 12. Upper compartment |
| Removal / Installation page S1-92 | Removal / Installation page S1-98 |
| | Disassembly / Assembly page S1-99 |

DASHBOARD

Removal / Installation

1. Disconnect the negative battery cable.

Warning

- Handling the air bag module improperly can accidentally deploy the air bag, which may seriously injure you. Read **SERVICE WARNINGS**, section T1, before handling the air bag module.

2. Remove the A-pillar trim. (Refer to page S1-100.)
3. Remove in the order shown in the figure, referring to **Removal note**.
4. Install in the reverse order of removal, referring to **Installation note**.

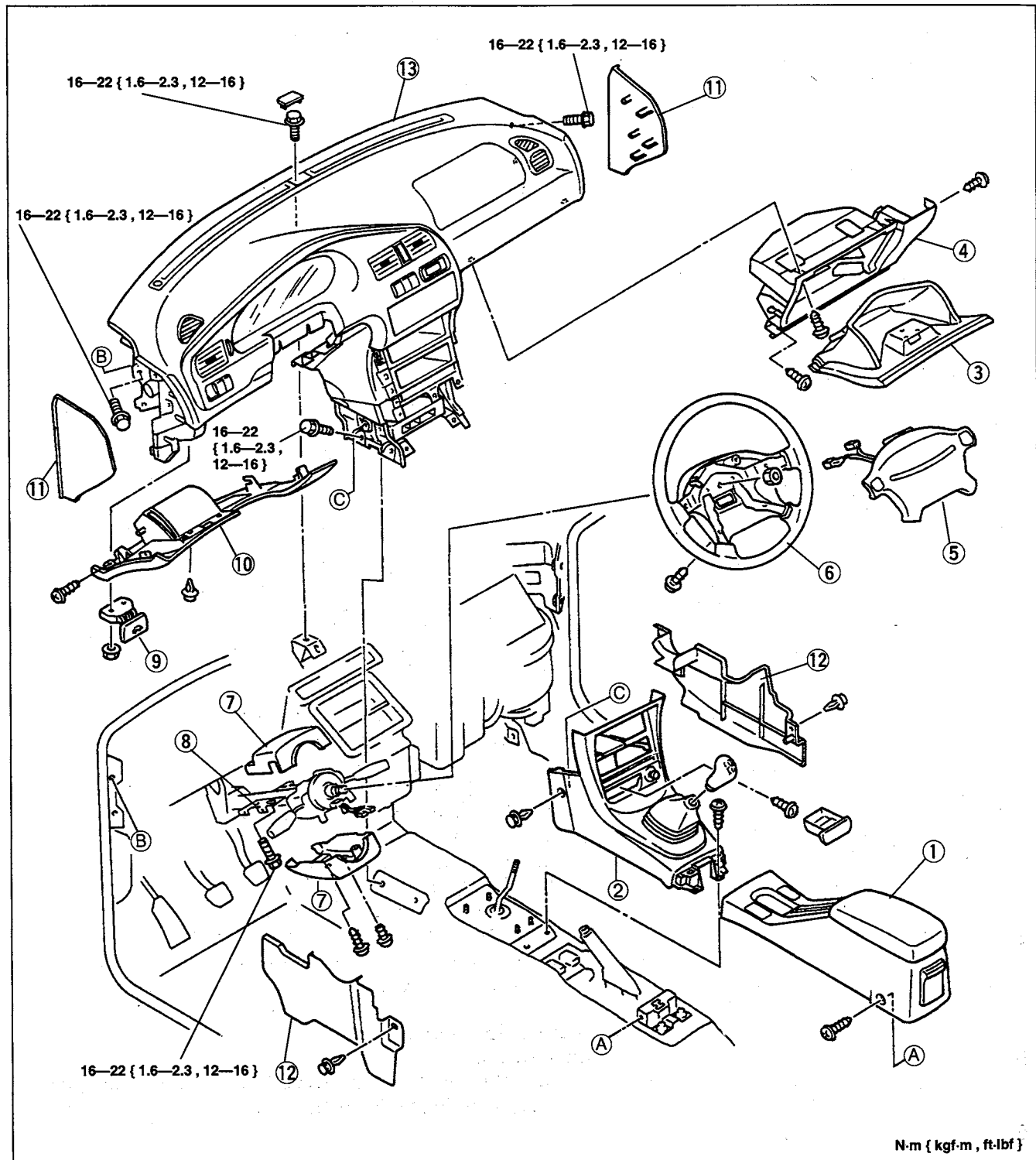

N·m { kgf·m, ft·lbf }

- | | |
|--|---|
| 1. Rear console
Removal / Installation page S1-89 | 8. Steering shaft |
| 2. Front console
Removal / Installation page S1-90 | 9. Hood release lever
Removal / Installation page S1- 5 |
| 3. Glove compartment
Removal / Installation page S1-87 | 10. Lower panel
Removal / Installation page S1-94 |
| 4. Glove compartment cover
Removal / Installation page S1-88 | 11. Side panel
Removal / Installation page S1-92 |
| 5. Driver-side air bag module
Removal / Installation section T1 | 12. Side wall
Removal / Installation page S1-93 |
| 6. Steering wheel
Removal / Installation section N | 13. Dashboard
Removal note below
Installation note below
Disassembly / Assembly page S1-86 |
| 7. Column cover
Removal / Installation page S1-95 | |

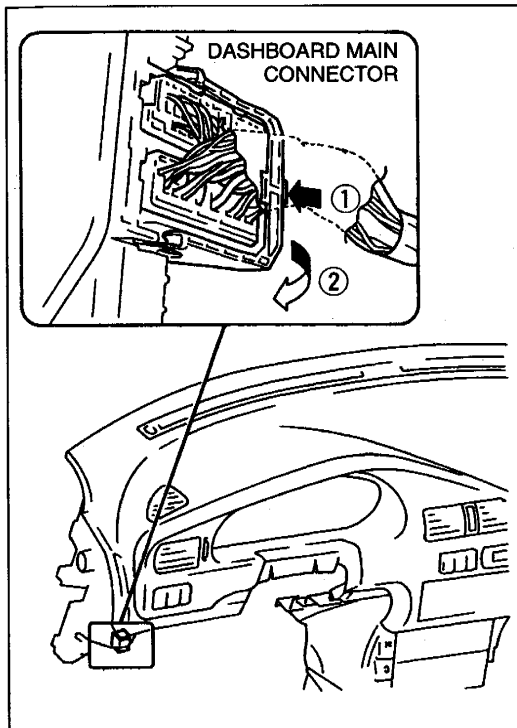

Removal note

Dashboard

With logic-type heater control unit

1. Remove the following connectors.
 - a. ECM connector (Refer to section F1.)
 - PCM connector (Refer to section F2.)
 - b. Blower unit connector (Refer to section U.)
 - c. Air mix actuator connector (Refer to section U.)
 - d. Mode actuator connector (Refer to section U.)
 - e. Dashboard main connector
 - f. CPU connector (Refer to section T1.)
 - g. Orange and blue clock spring connectors (Refer to section T1.)
2. Disconnect the cabin temperature sensor from the air duct. (Refer to section U.)

With wire-type heater control unit

1. Remove the following wires.
 - a. Air mix wire (Refer to section U.)
 - b. Air intake wire (Refer to section U.)
 - c. Mode wire (Refer to section U.)
2. Remove the following connectors.
 - a. Dashboard main connector
 - b. CPU connector (Refer to section T1.)
 - c. ECM connector (Refer to section F1.)
 - PCM connector (Refer to section F2.)
 - d. Orange and blue clock spring connectors (Refer to section T1.)

Installation note

Dashboard

On vehicles with a wire-type heater control unit, adjust each wire. (Refer to section U.)

Disassembly / Assembly

1. Disassemble in the order shown in the figure.
2. Assemble in the reverse order of disassembly.

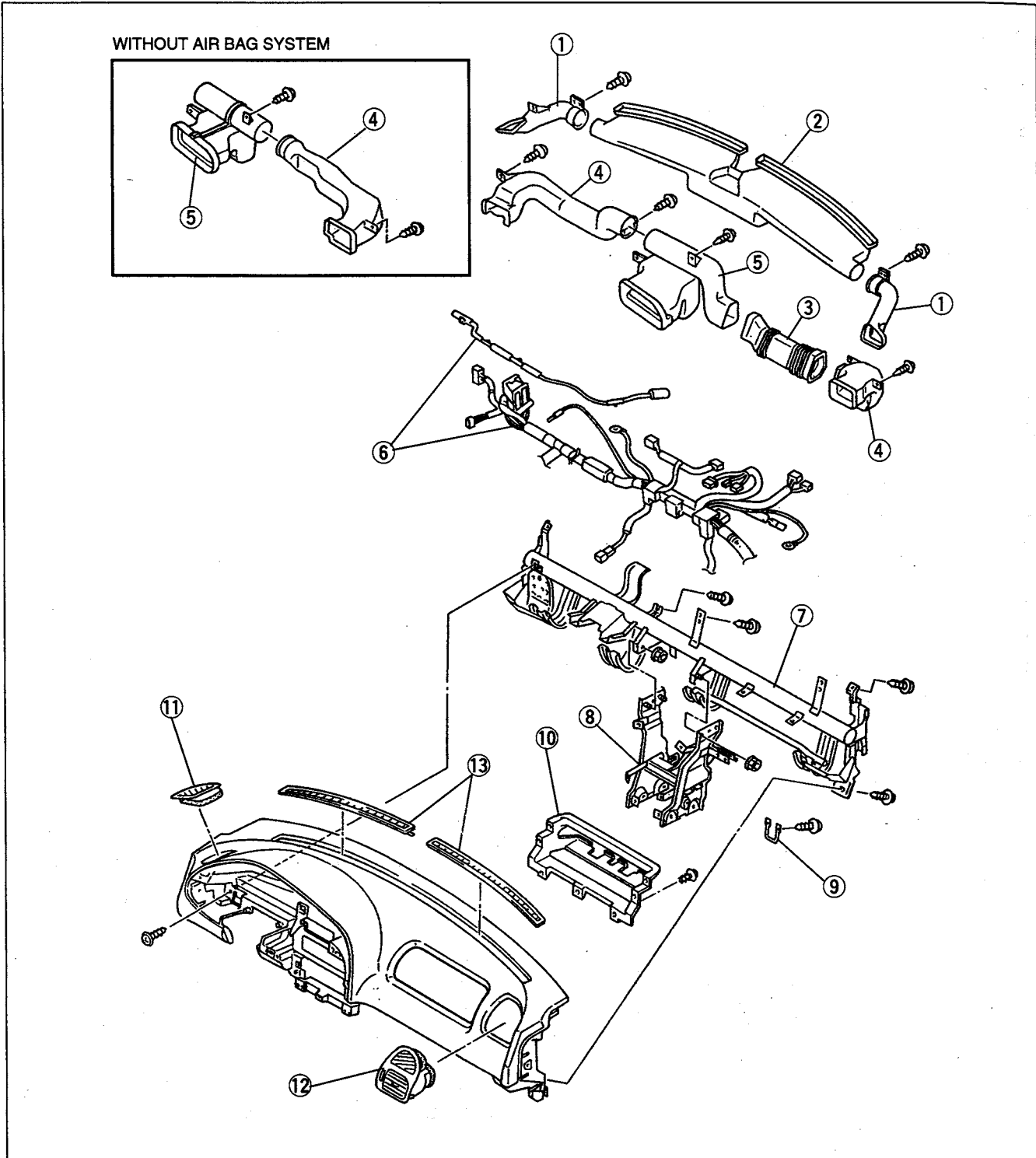

1. Side demister nozzle
2. Defroster nozzle
3. No.1 duct
4. No.2 duct
5. Center duct
6. Dashboard harness
7. Dashboard member

8. Dashboard center member
9. Glove compartment lock striker
10. Air bag case
11. Demister grille
12. Side ventilator
13. Defroster grille

GLOVE COMPARTMENT

Removal / Installation

1. Remove as shown in the figure, referring to **Removal note**.
2. Install in the reverse order of removal.

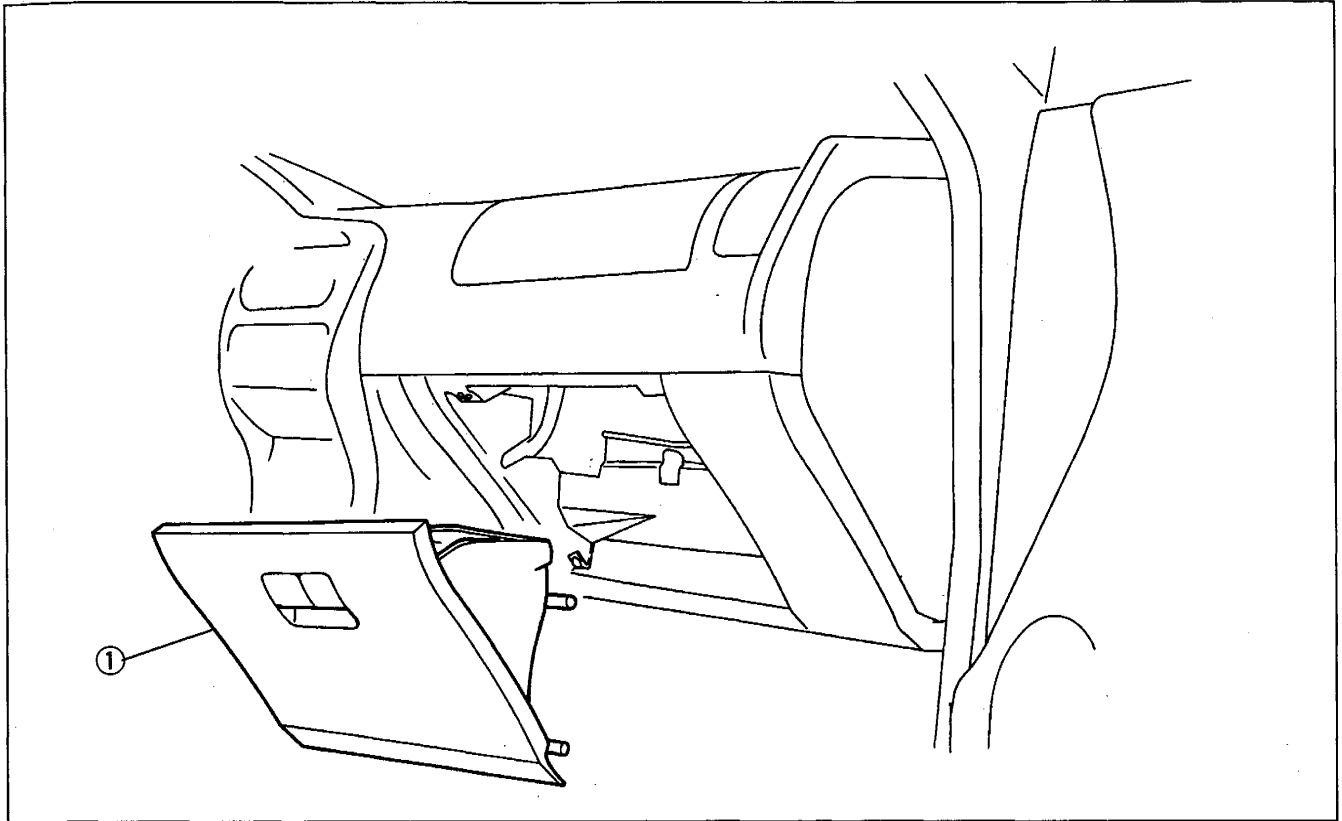

1. Glove compartment
 Removal note below
 Disassembly / Assembly page S1-88

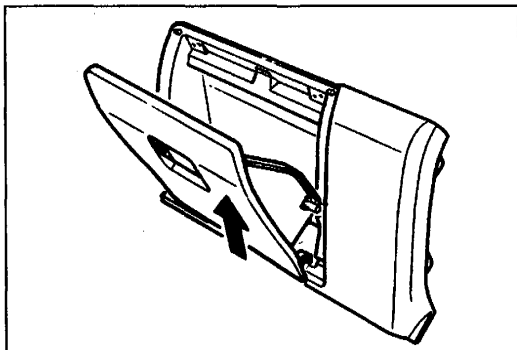

Removal note
Glove compartment

1. Open the glove compartment and pull up on the right side.

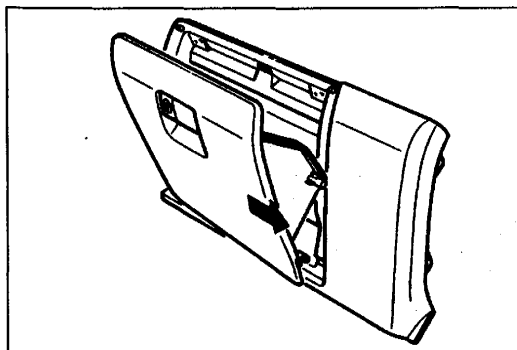

2. Slide the glove compartment to the right to remove it.

Disassembly / Assembly

1. Disassemble in the order shown in the figure.
2. Assemble in the reverse order of disassembly.

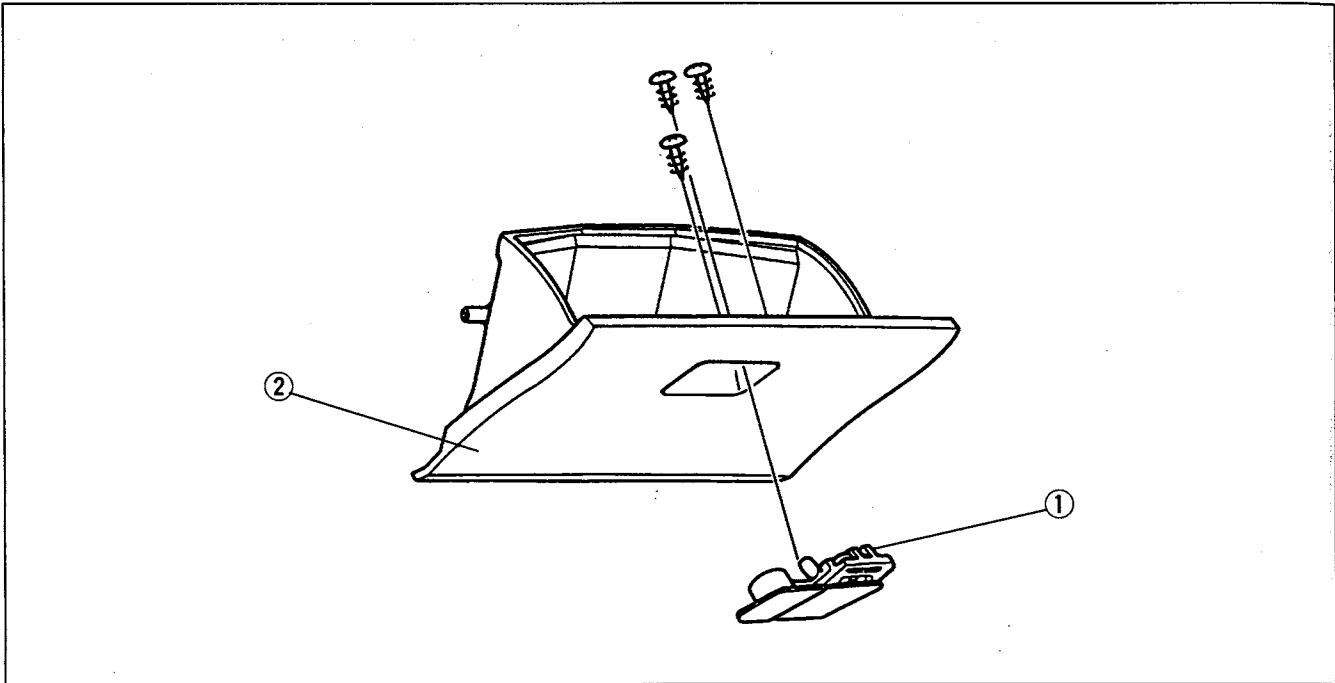

1. Glove compartment lock

2. Glove compartment

GLOVE COMPARTMENT COVER**Removal / Installation**

1. Remove the side panel. (Refer to page S1-92.)
2. Remove the glove compartment. (Refer to page S1-87.)
3. Remove as shown in the figure.
4. Install in the reverse order of removal.

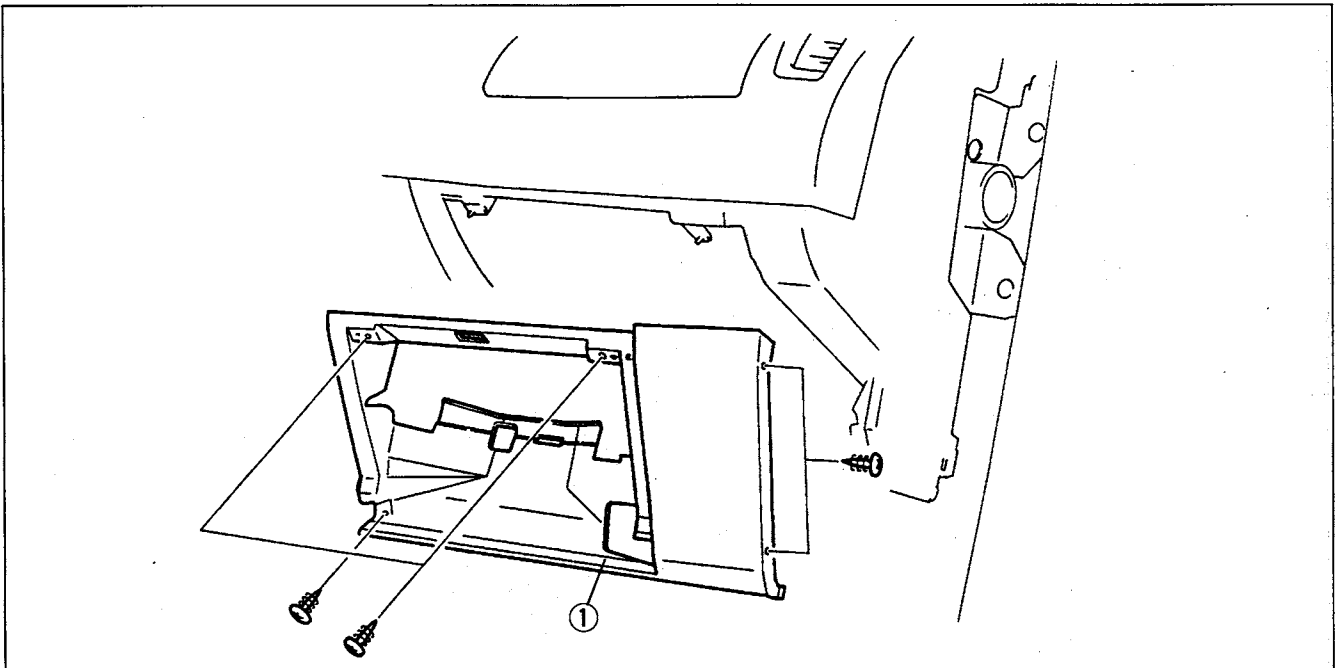

1. Glove compartment cover

REAR CONSOLE
Removal / Installation

1. Remove as shown in the figure.
2. Install in the reverse order of removal.

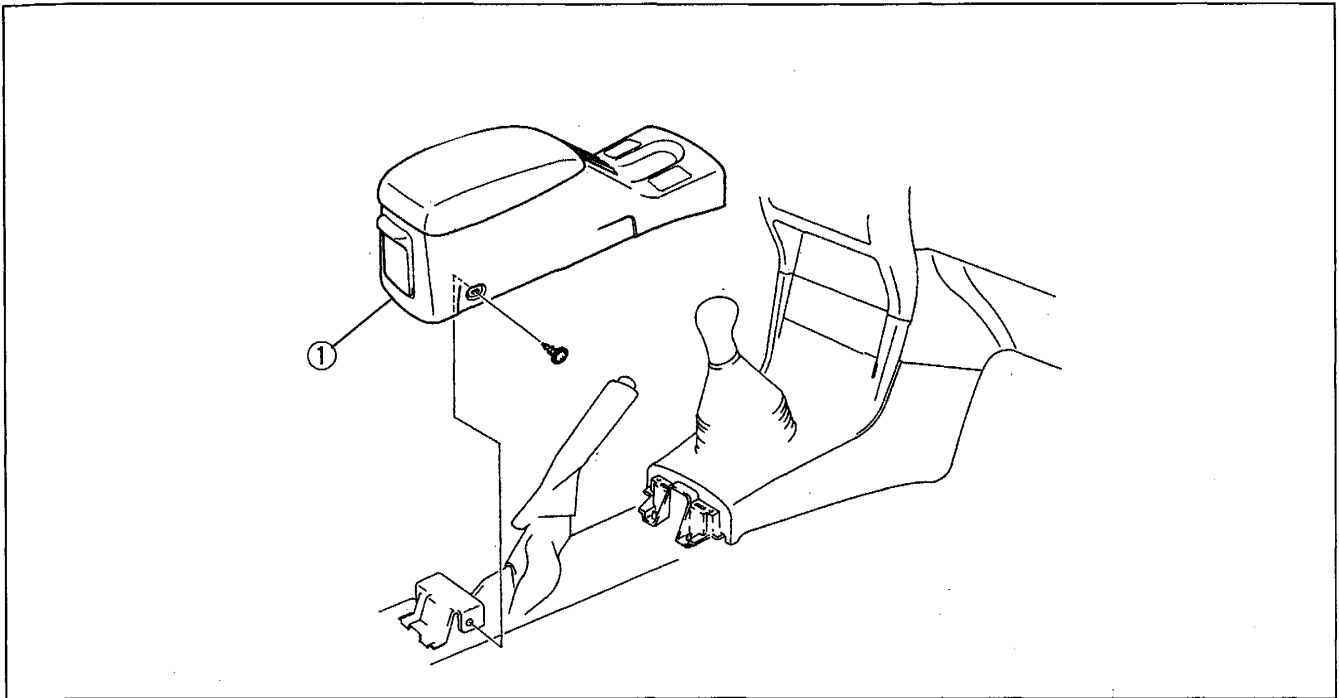

1. Rear console
Disassembly / Assembly below

Disassembly / Assembly

1. Disassemble in the order shown in the figure.
2. Assemble in the reverse order of disassembly.

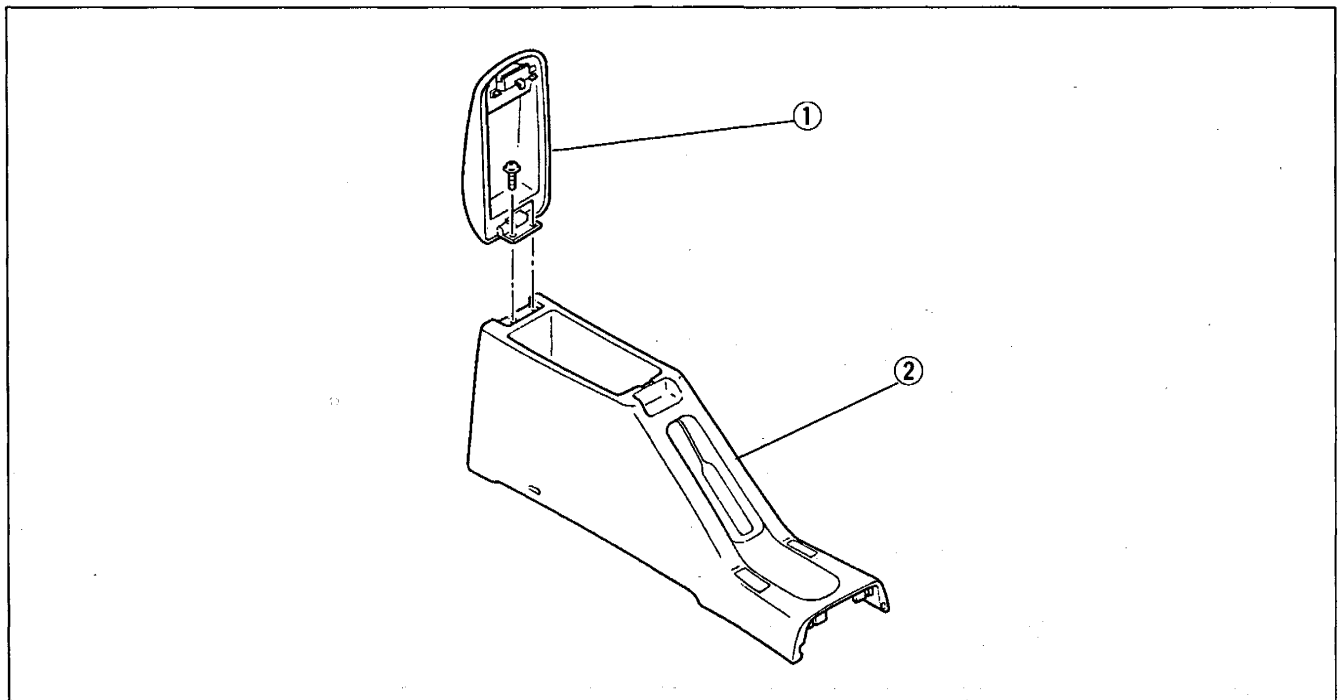

1. Rear console lid

2. Rear console

FRONT CONSOLE**Removal / Installation**

1. Disconnect the negative battery cable.
2. Remove the rear console. (Refer to page S1-89.)
3. Remove in the order shown in the figure.
4. Install in the reverse order of removal.

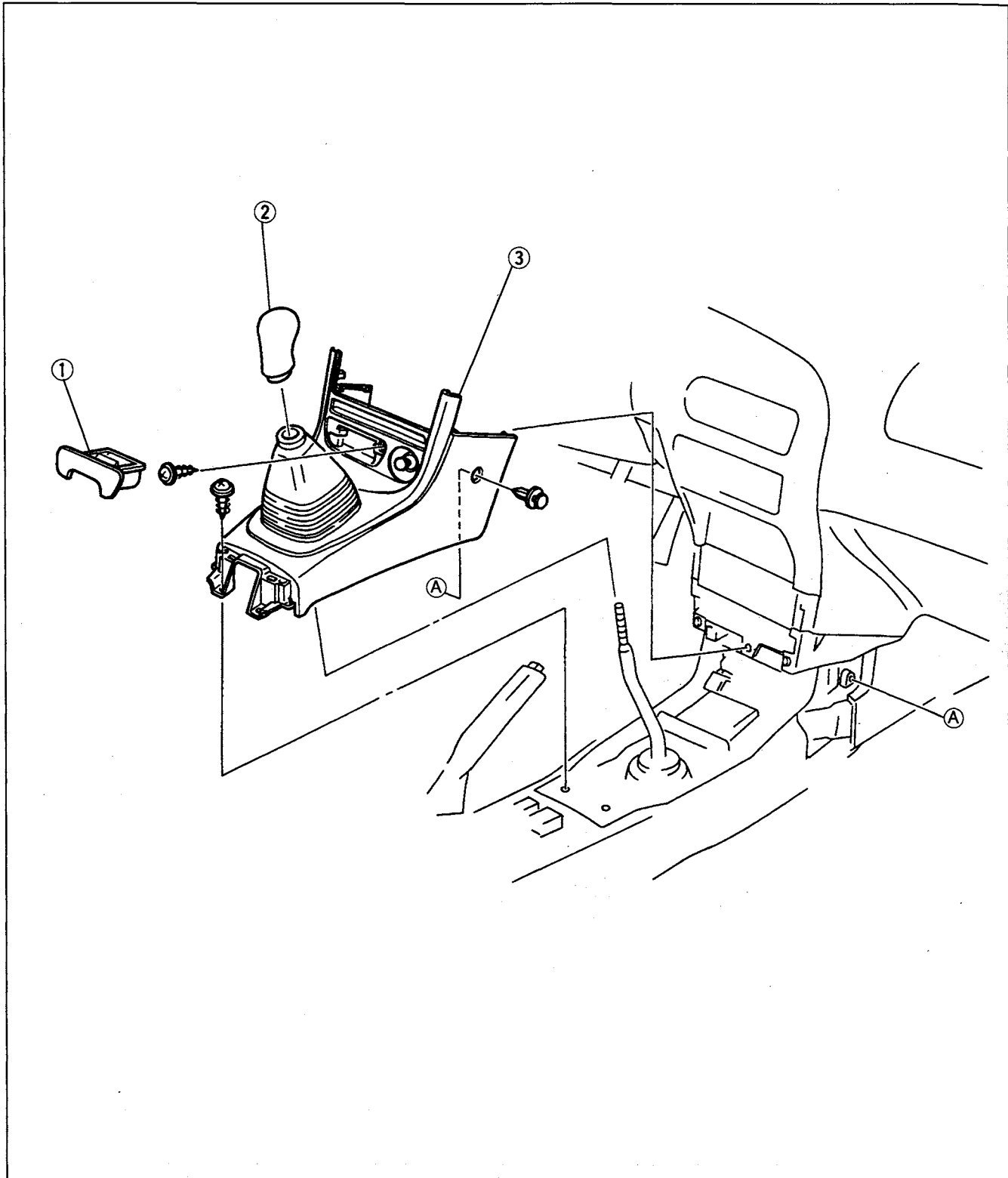

1. Front ashtray
2. Shift lever knob (MTX)

3. Front console
Disassembly / Assembly page S1-91

Disassembly / Assembly

1. Disassemble in the order shown in the figure.
2. Assemble in the reverse order of disassembly.

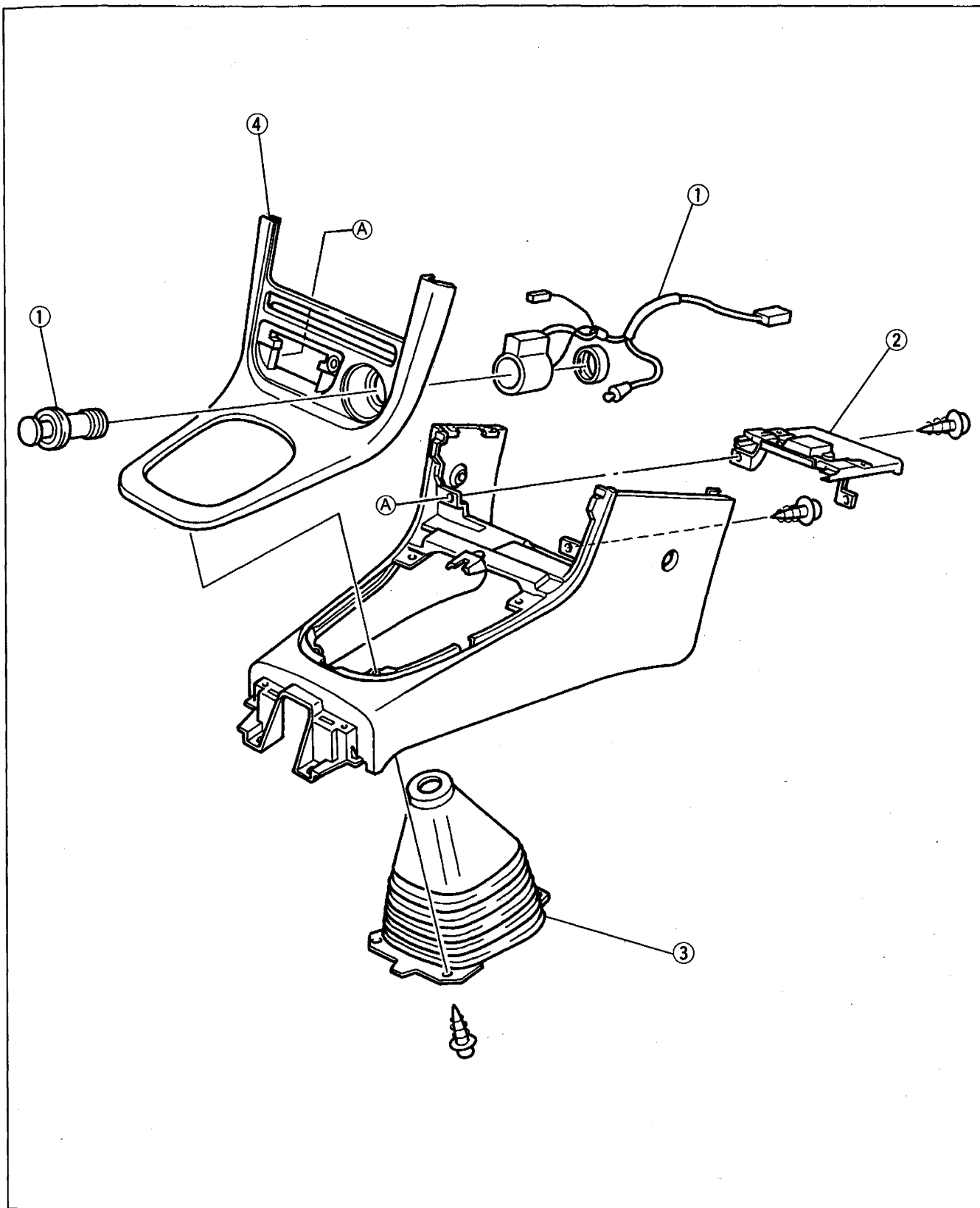

1. Cigarette lighter
2. Front ashtray bracket

3. Change boot
4. Front console panel

SIDE PANEL

Removal / Installation

1. Remove as shown in the figure, referring to **Removal note**.
2. Install in the reverse order of removal.

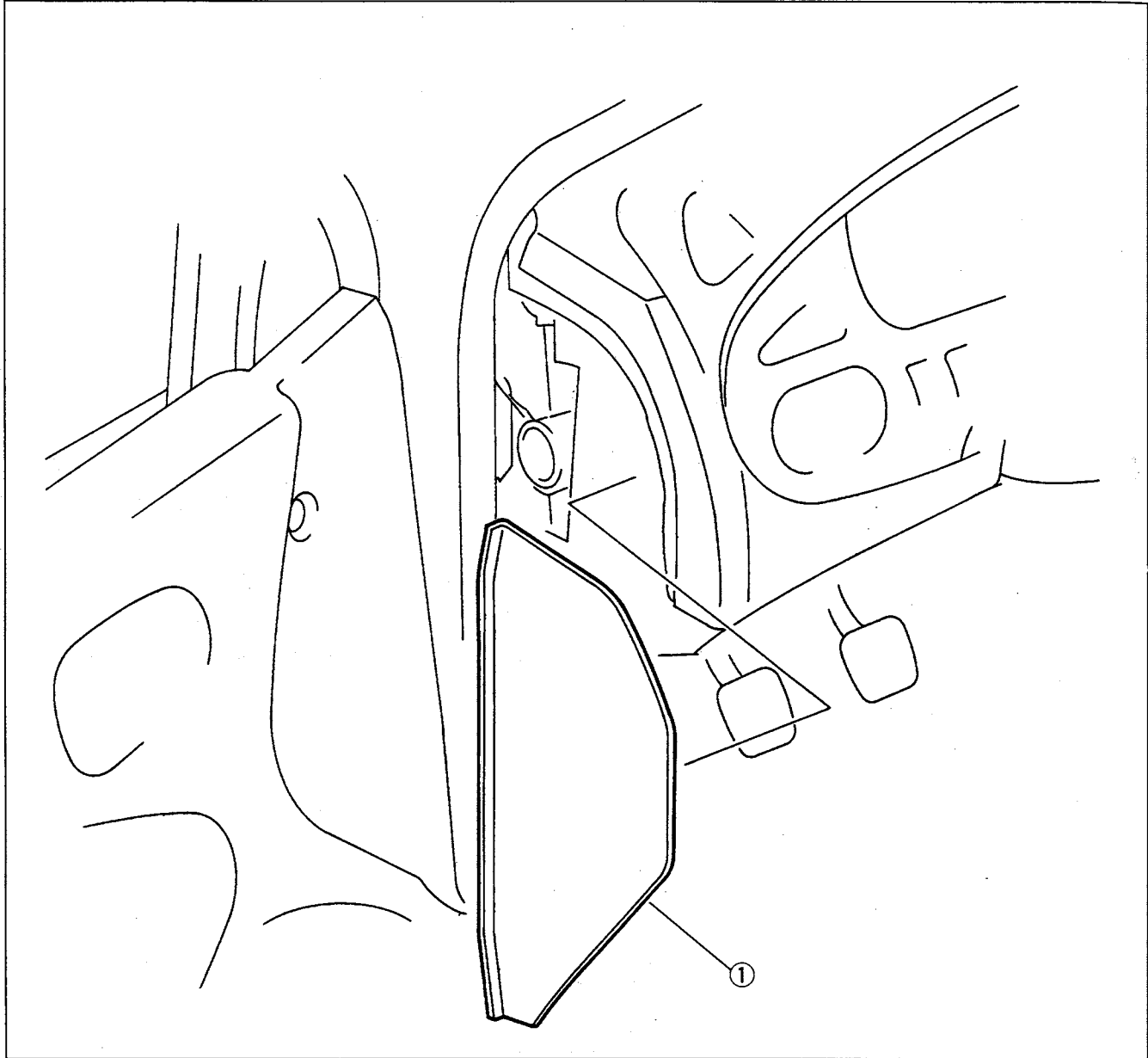

1. Side panel
Removal note below

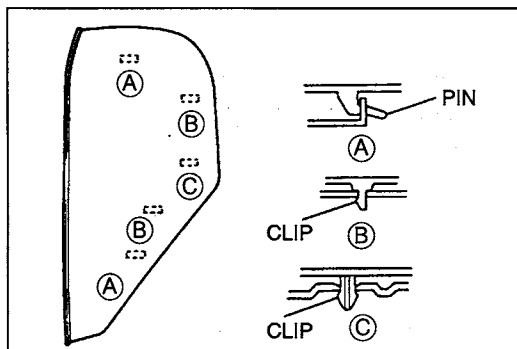

Removal note Side panel

1. Pull the front edge of the side panel forward to remove the clips from the body.
2. Pull the side panel forward to remove the pins from the body.

SIDE WALL

Removal / Installation

1. Remove the front console. (Refer to page S1-90.)
2. Remove as shown in the figure, referring to **Removal note**.
3. Install in the reverse order of removal.

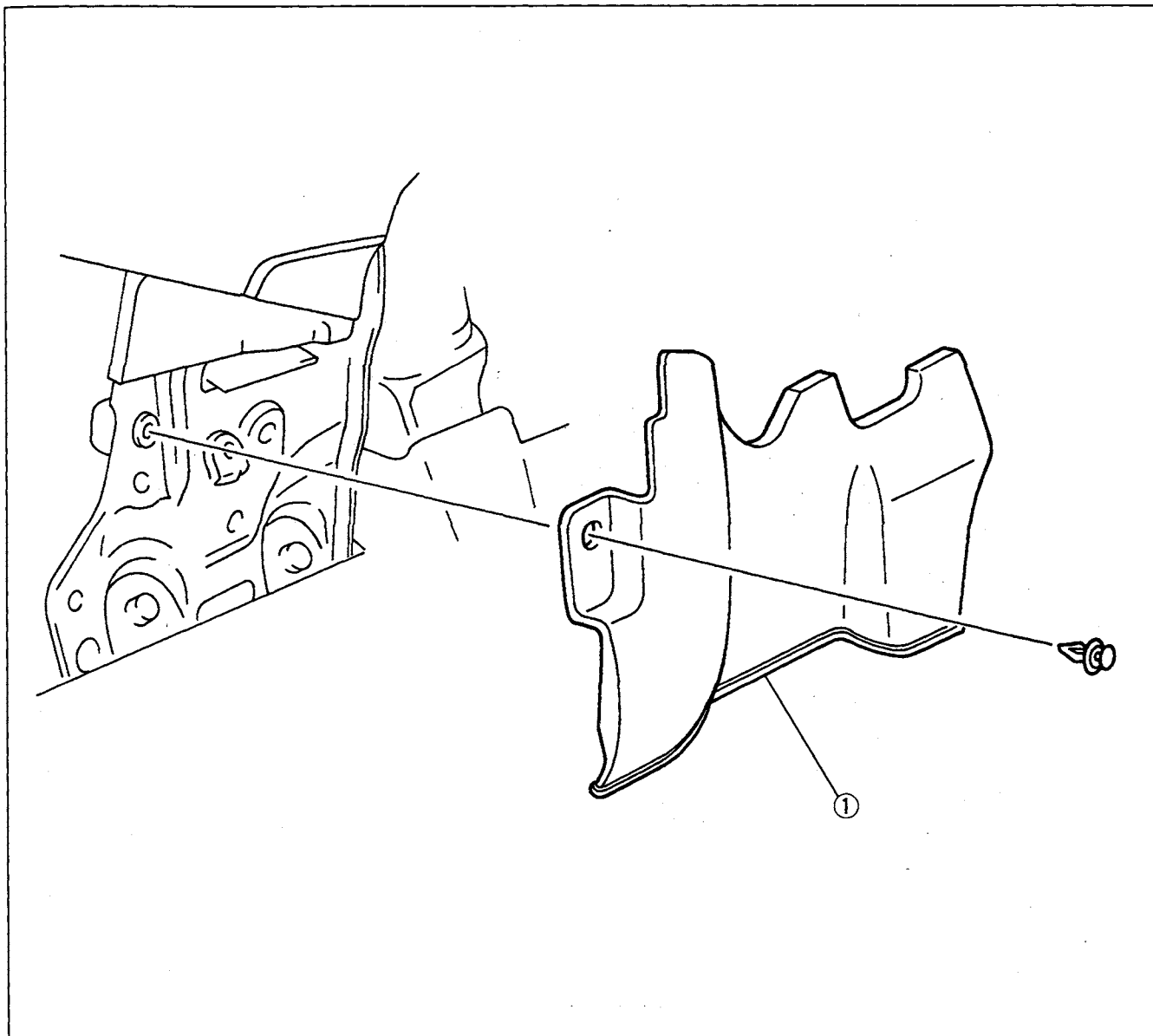

1. Side wall
Removal note below

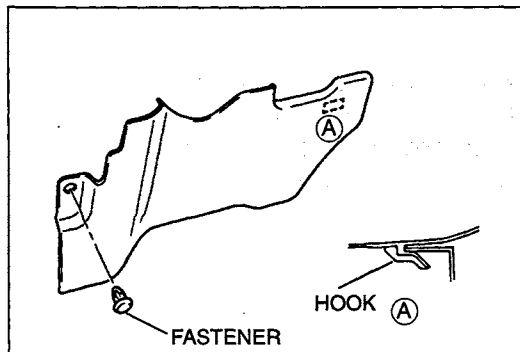

Removal note
Side wall

1. Remove the side wall installation fastener.
2. Pull the side wall forward to disengage the hook.

LOWER PANEL

Removal / Installation

1. Remove in the order shown in the figure, referring to **Removal note**.
2. Install in the reverse order of removal.

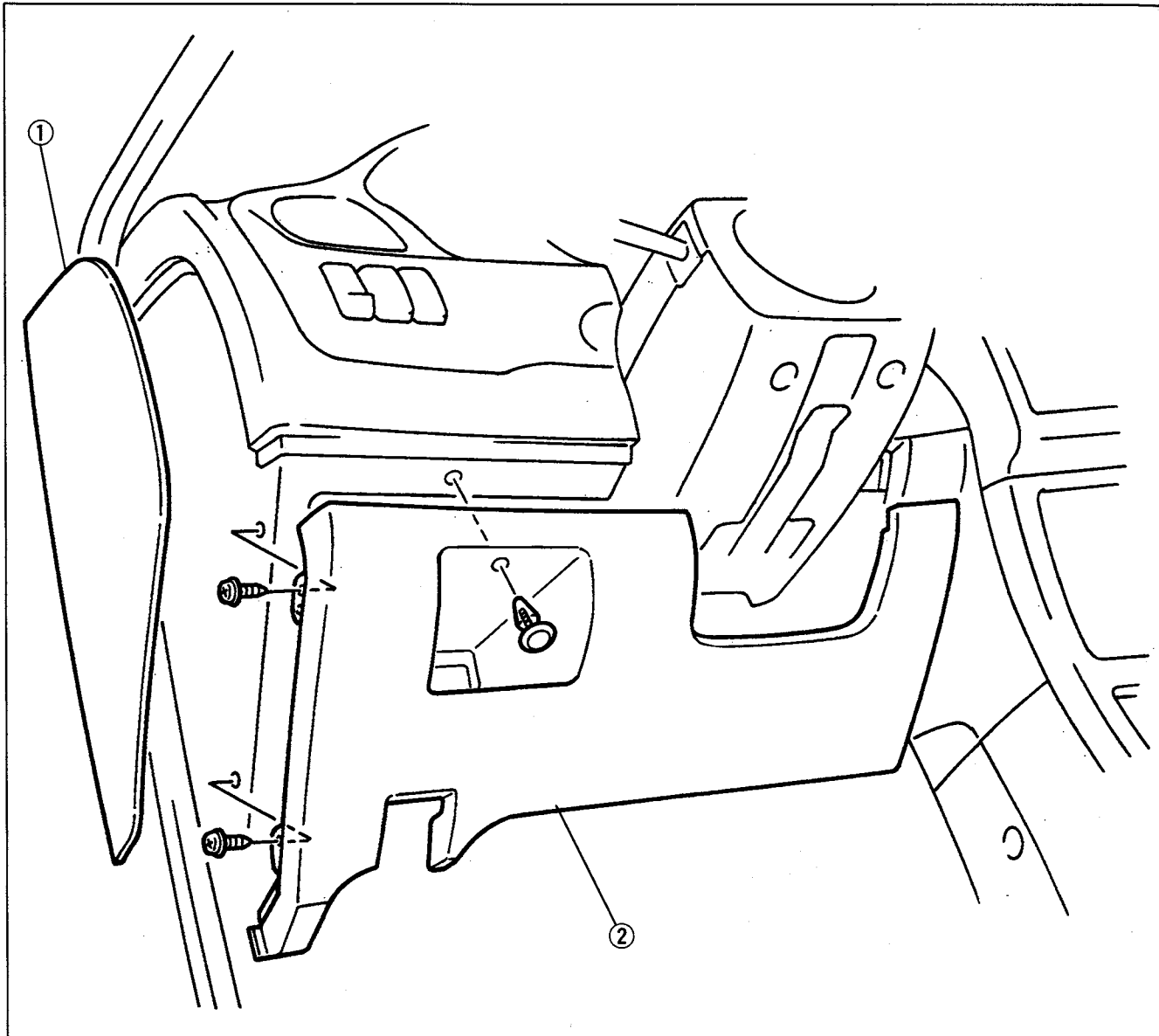

1. Side panel
Removal / Installation page S1-92

2. Lower panel
Removal note below

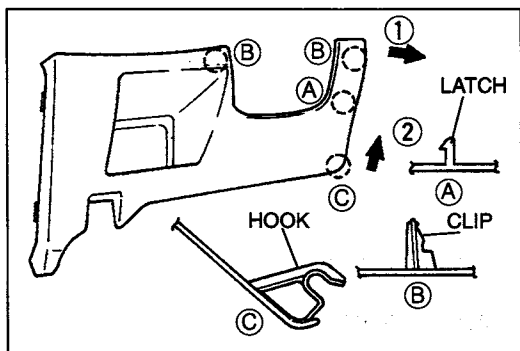

Removal note Lower panel

1. Pull the lower panel forward as indicated by arrow ① to disengage the clip from the dashboard.
2. Pull the lower panel upward as indicated by arrow ② to disengage the hook from the dashboard.

COLUMN COVER**Removal / Installation**

1. Remove in the order shown in the figure.
2. Install in the reverse order of removal.

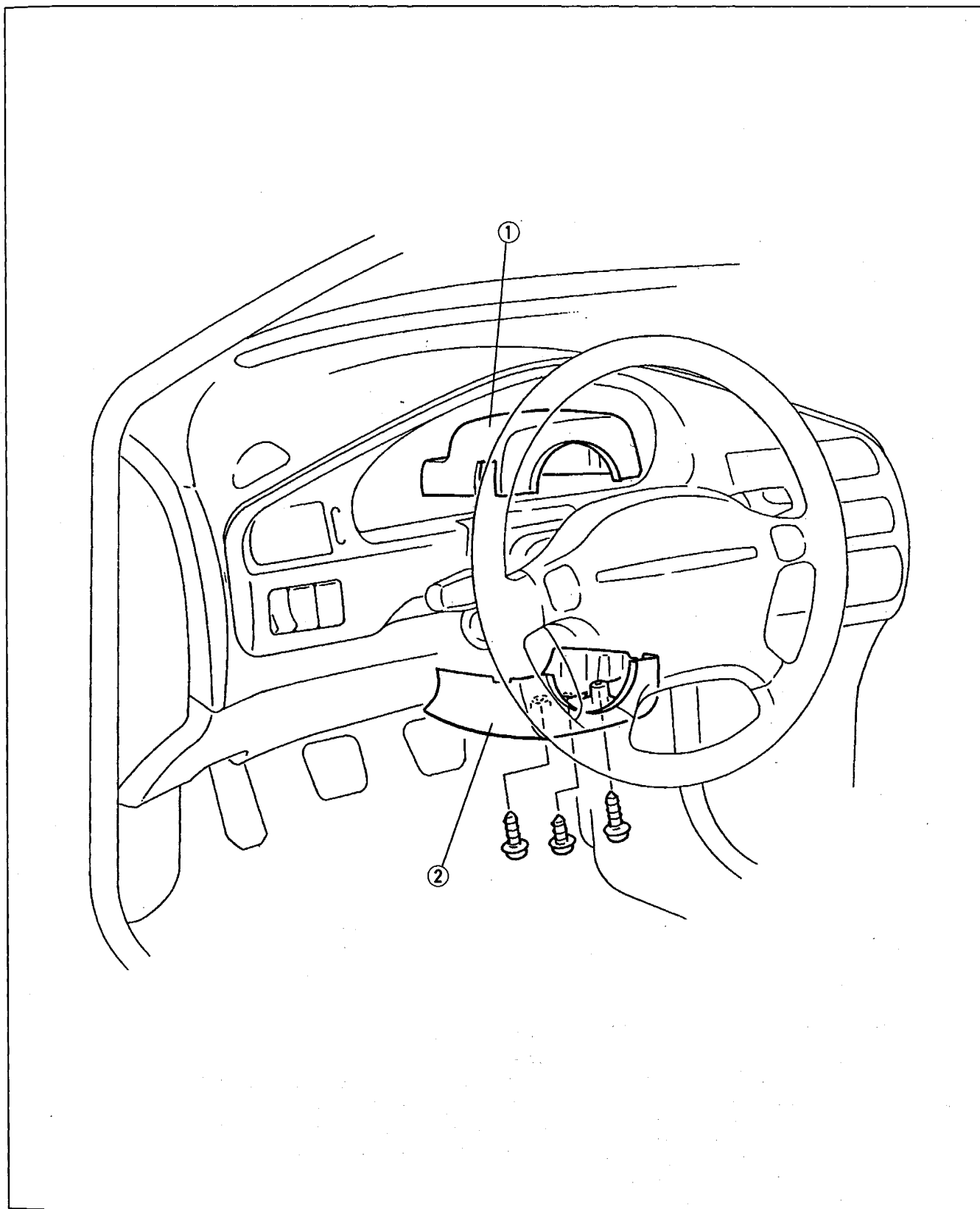

1. Upper column cover

2. Lower column cover

METER HOOD

Removal / Installation

1. Remove the upper column cover. (Refer to page S1-95.)
2. Remove the front console. (Refer to page S1-90.)
3. Remove in the order shown in the figure, referring to **Removal note**.
4. Install in the reverse order of removal.

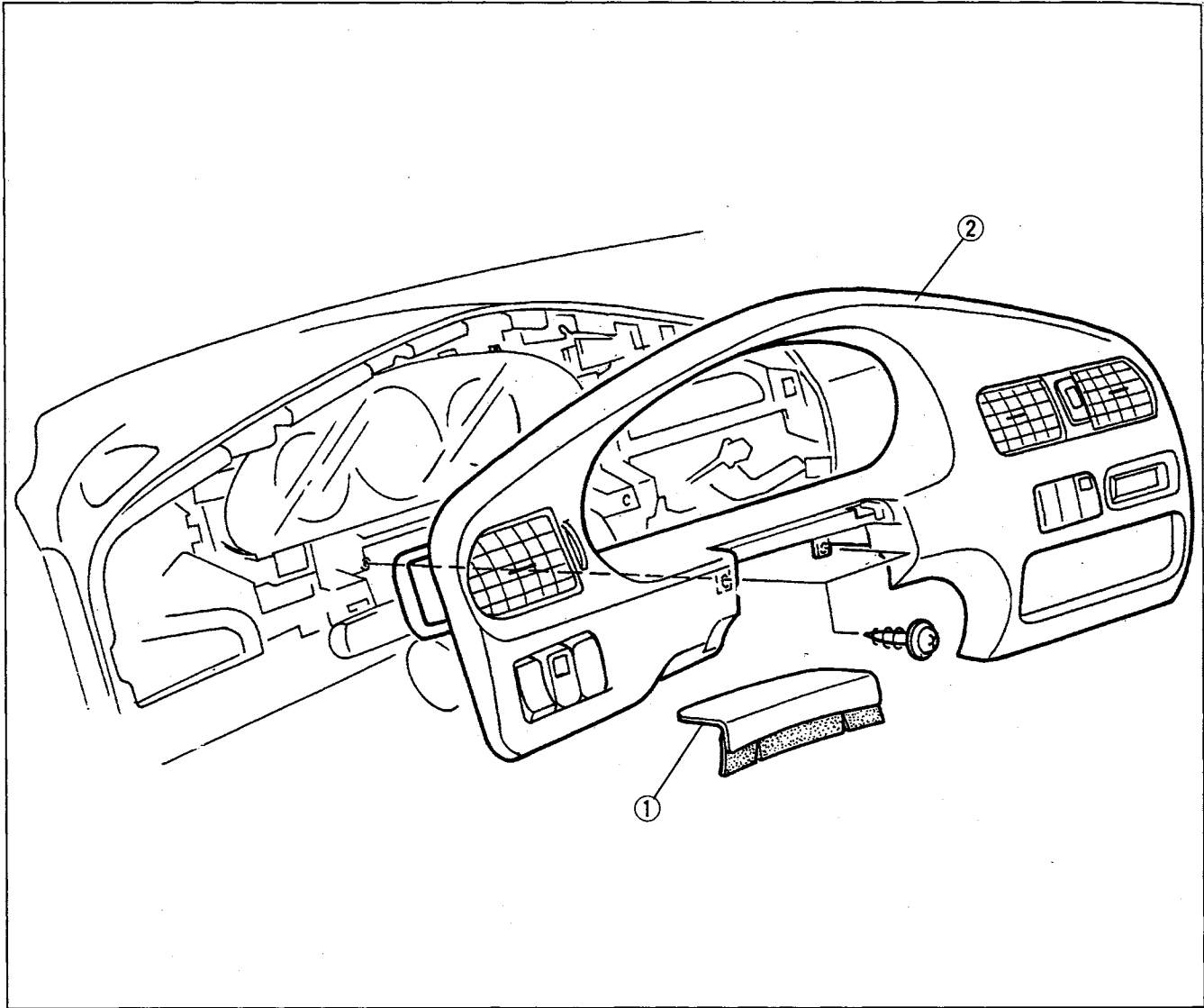

1. Cover

2. Meter hood

Removal note below
 Disassembly / Assembly page S1-97

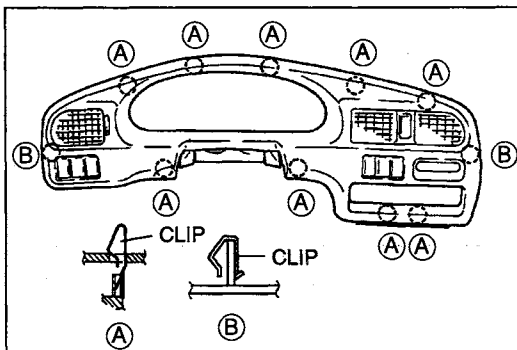

Removal note Meter hood

Pull the meter hood forward to disengage the clips from the body.

Disassembly / Assembly

1. Disassemble in the order shown in the figure.
2. Assemble in the reverse order of disassembly.

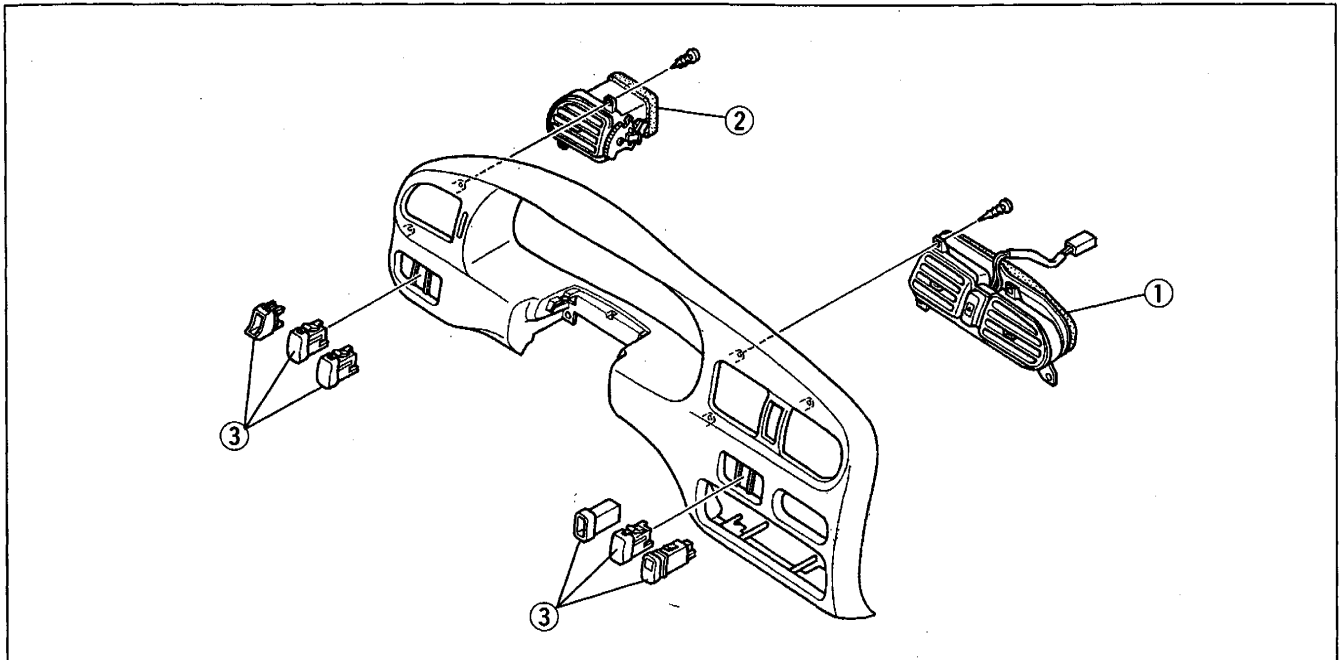

1. Louver ventilator grille
2. Side ventilator grille

3. Switch

**CENTER LOWER PANEL
Removal / Installation**

1. Remove the lower panel. (Refer to page S1-94.)
2. Remove the glove compartment cover. (Refer to page S1-88.)
3. Remove the front console. (Refer to page S1-90.)
4. Remove as shown in the figure.
5. Install in the reverse order of removal.

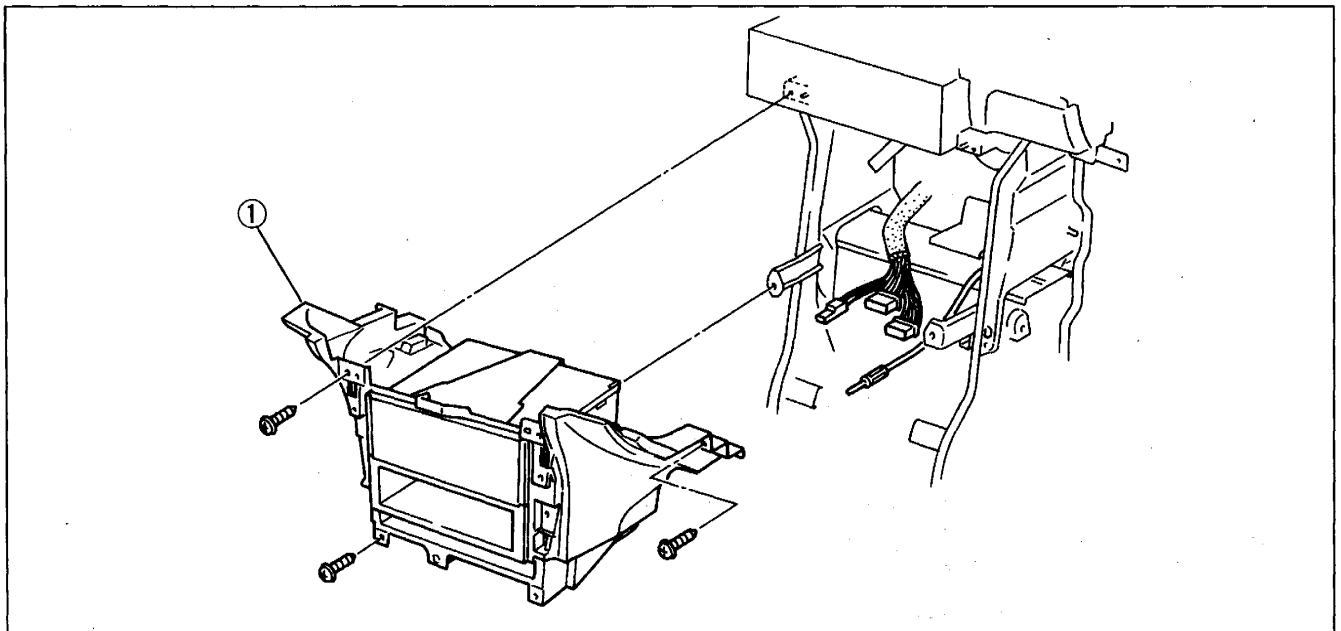

1. Center lower panel

UPPER COMPARTMENT

Removal / Installation

1. Remove the dashboard. (Refer to page S1-84.)
2. Remove the No.2 duct. (Refer to page S1-86.)
3. Remove in the order shown in the figure.
4. Install in the reverse order of removal.

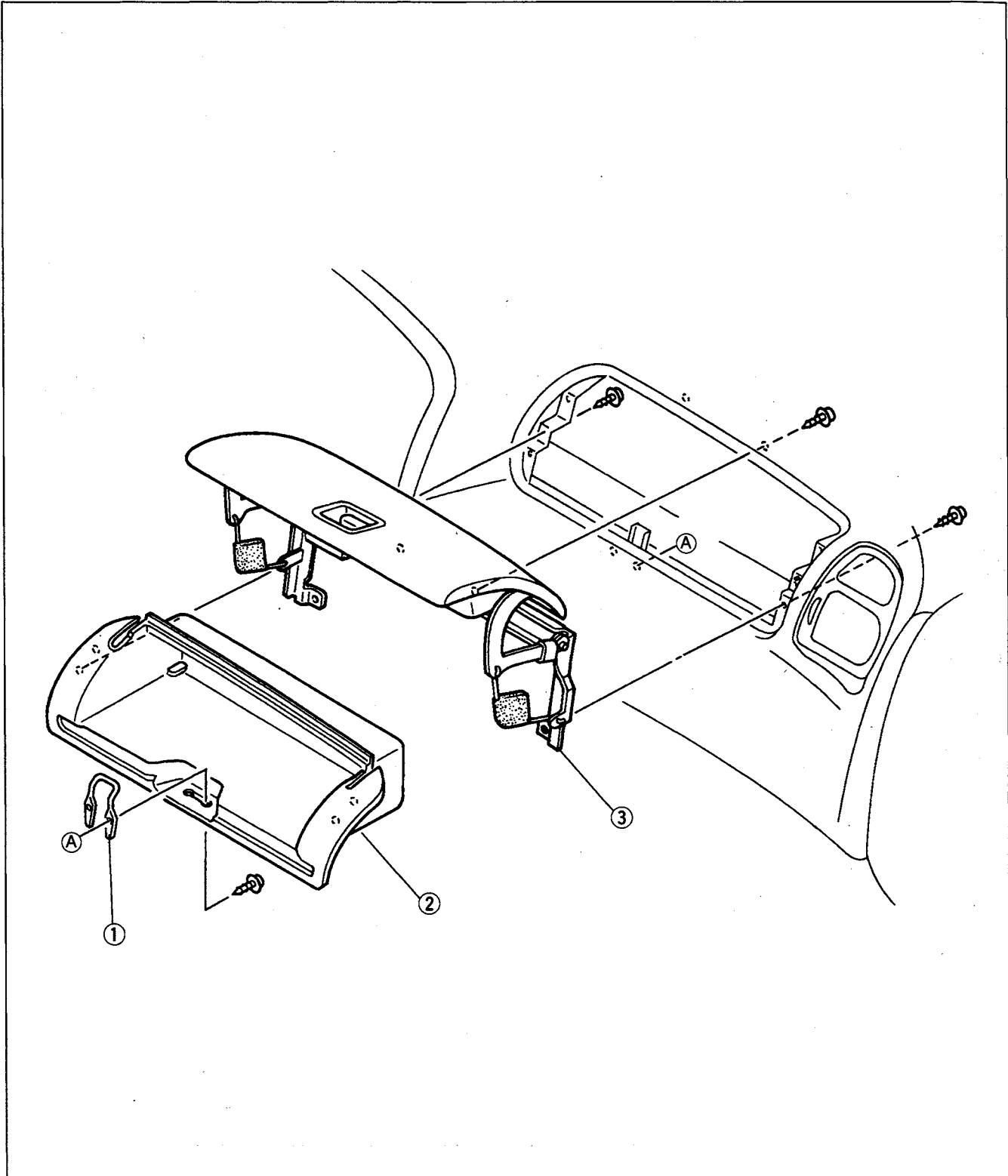

1. Upper compartment striker
2. Upper compartment case

3. Upper compartment lid
Disassembly / Assembly page S1-99

Disassembly / Assembly

1. Disassemble in the order shown in the figure.
2. Assemble in the reverse order of disassembly.

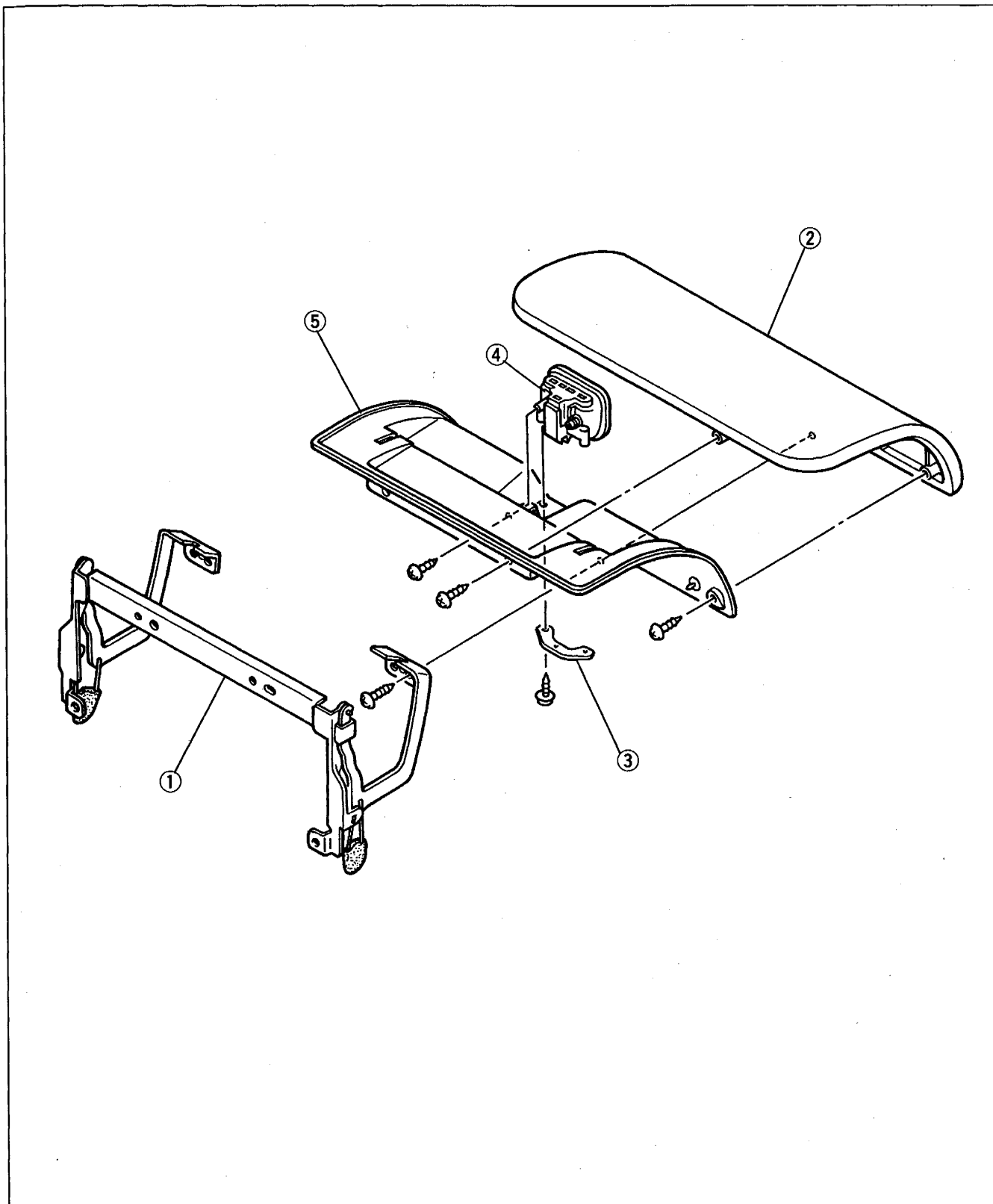

1. Upper compartment hinge
2. Upper compartment lid
3. Bracket

4. Upper compartment lock
5. Upper compartment inner lid

TRIM

A-PILLAR TRIM

Removal / Installation

1. Remove in the order shown in the figure, referring to **Removal note**.
2. Install in the reverse order of removal.

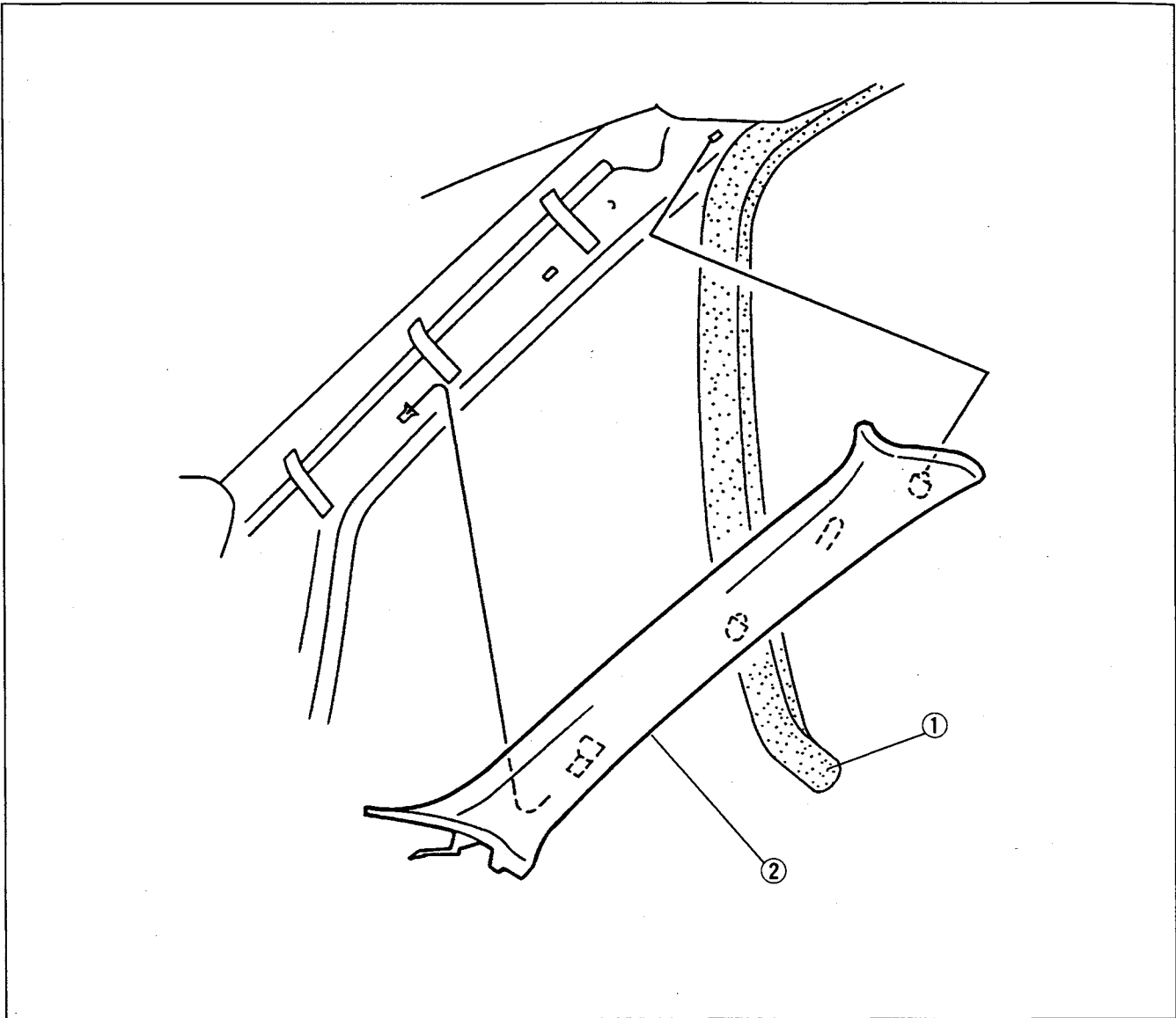

1. Seaming welt

2. A-pillar trim

Removal note below

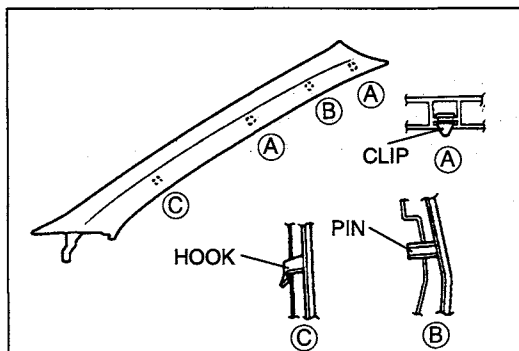

Removal note

A-pillar trim

1. Pull the A-pillar trim forward to disengage the clips and pin from the body.
2. Pull the A-pillar trim upward to disengage the hook from the body.

B-PILLAR LOWER TRIM

Removal / Installation

1. Remove the front scuff plate (Refer to page S1-105.) and rear scuff plate (Refer to page S1-106.).
2. Remove as shown in the figure, referring to **Removal note**.
3. Install in the reverse order of removal.

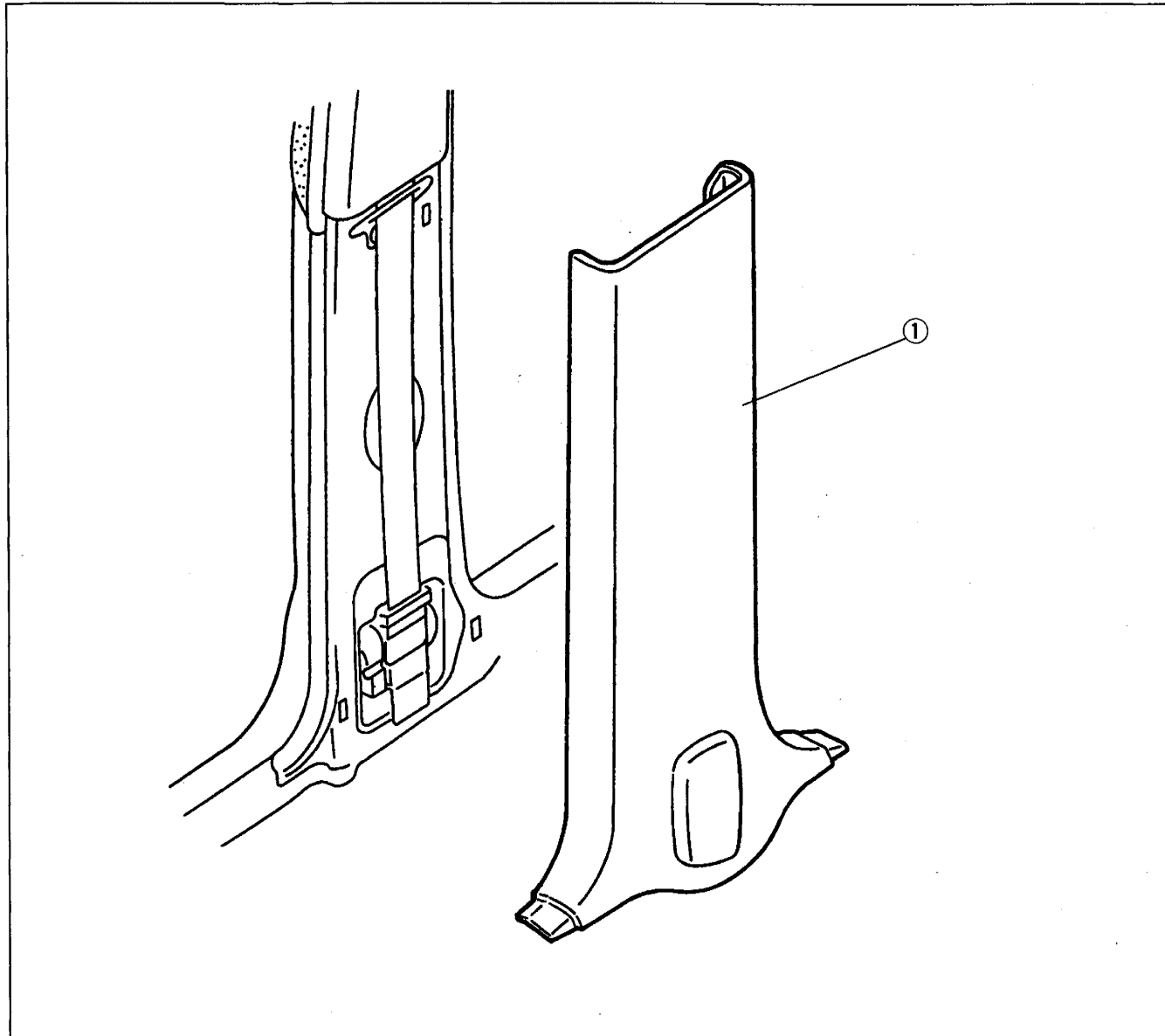

1. B-pillar lower trim
Removal note below

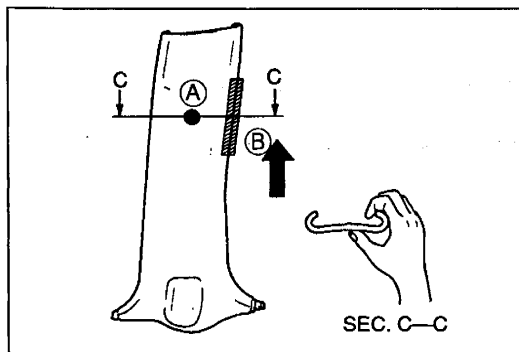

Removal note
B-pillar lower trim

1. Bend the sides of the B-pillar lower trim at area B while pushing the trim at point A as shown.
2. Pull the B-pillar lower trim upward to disengage it from the body.

B-PILLAR UPPER TRIM

Removal / Installation

1. Remove the B-pillar lower trim. (Refer to page S1-101.)
2. Remove the front seat belt upper anchor. (Refer to page S1-117.)
3. Remove in the order shown in the figure, referring to **Removal note**.
4. Install in the reverse order of removal.

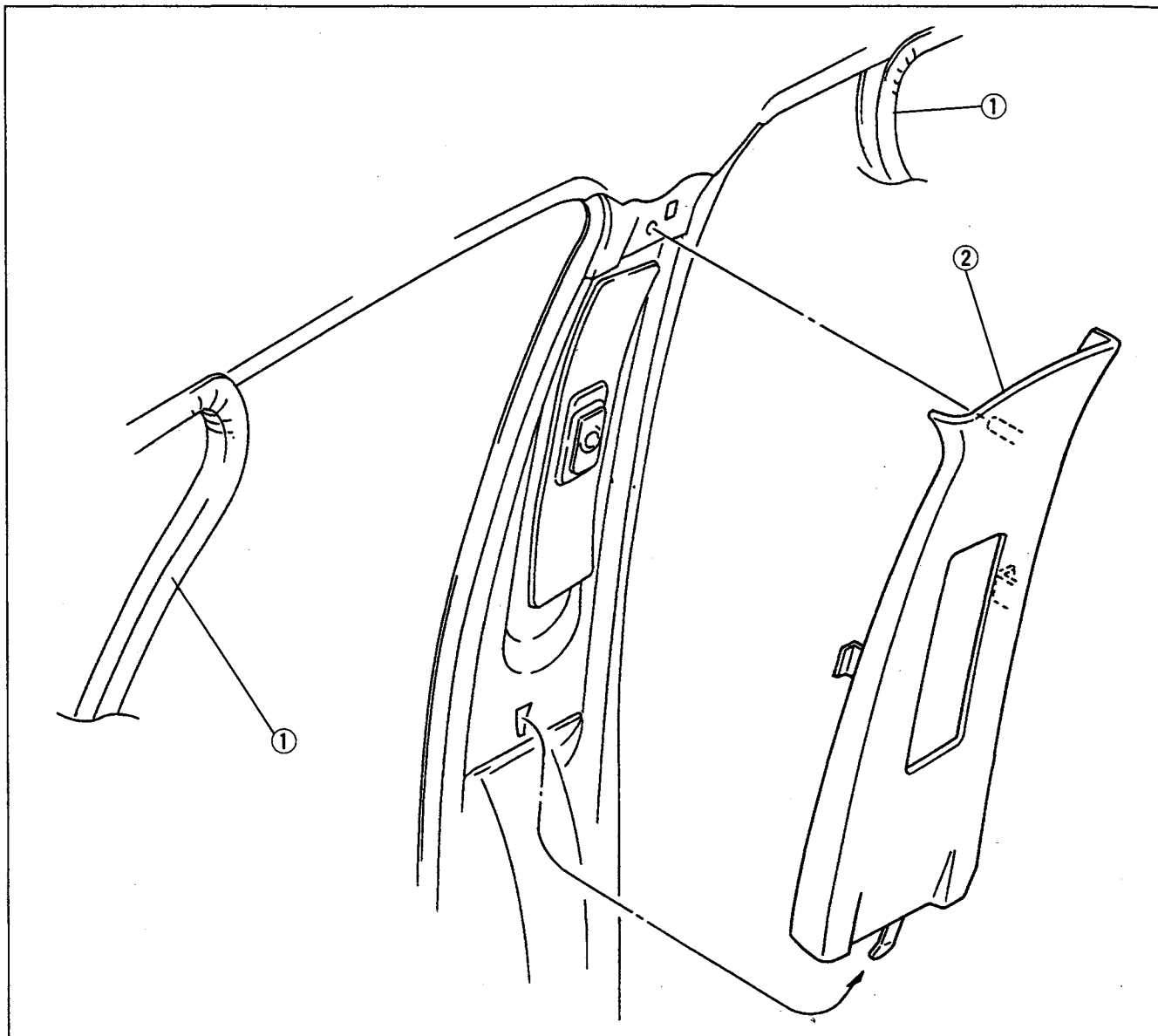

1. Seaming welt

2. B-pillar upper trim
Removal note below

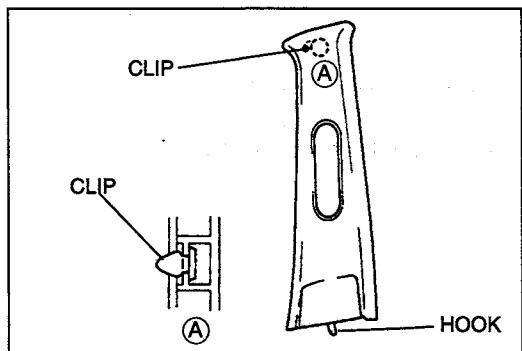

Removal note

B-pillar upper trim

Pull the B-pillar upper trim to disengage the clip from the body.

C-PILLAR TRIM

Removal / Installation

1. Remove the rear package trim. (Refer to page S1-109.)
2. Remove in the order shown in the figure, referring to **Removal note**.
3. Install in the reverse order of removal.

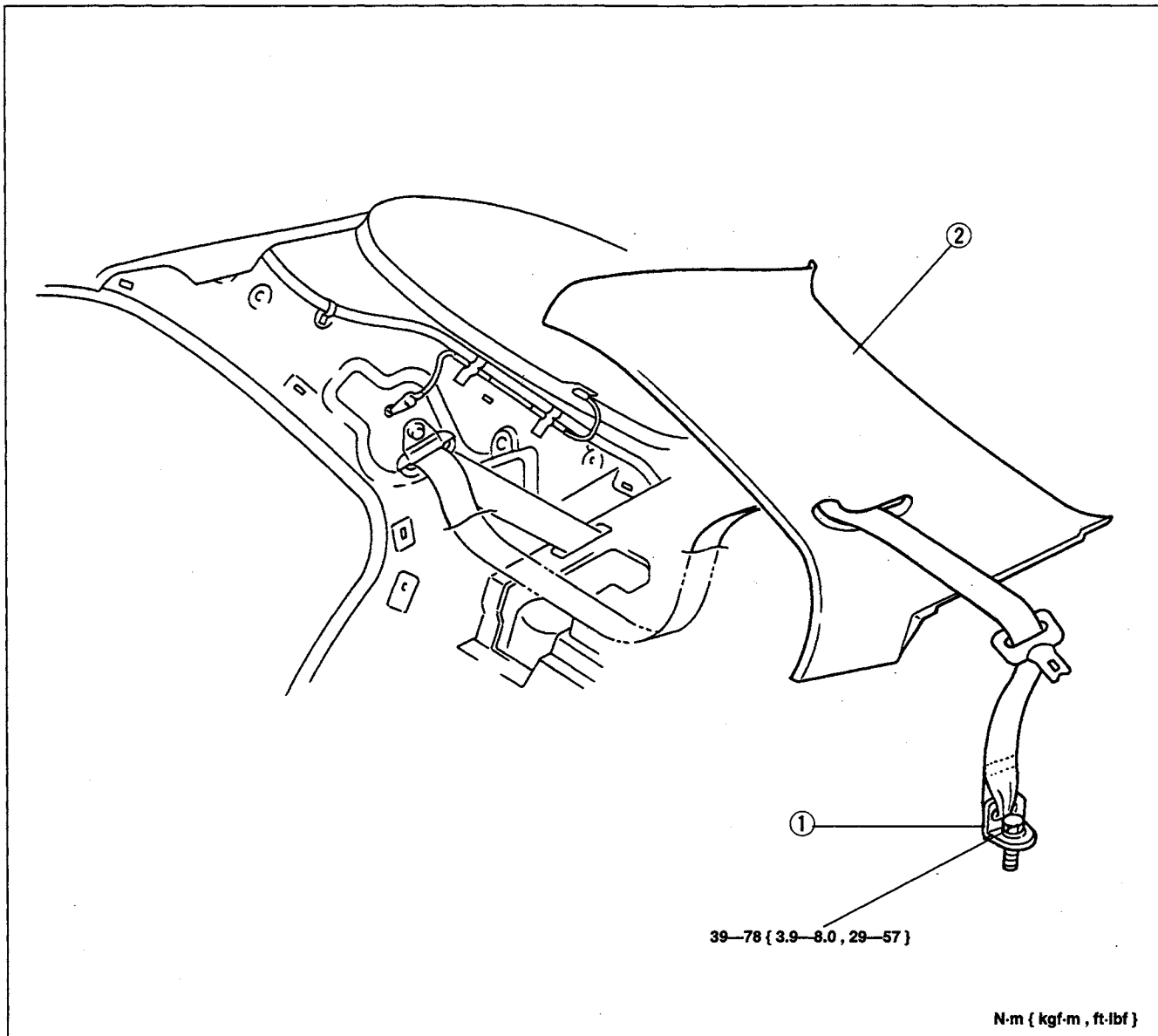

1. Rear seat belt lower anchor
Removal / Installation page S1-119

2. C-pillar trim
Removal note below

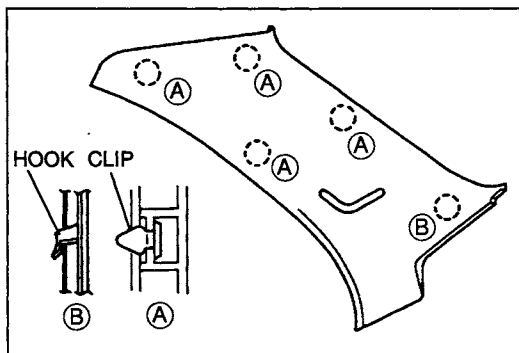

Removal note

C-pillar trim

1. Pull the C-pillar trim forward to disengage the clips from the body.
2. Pull the C-pillar trim upward to disengage the hook from the body.

FRONT SIDE TRIM Removal / Installation

1. Remove in the order shown in the figure, referring to **Removal note**.
2. Install in the reverse order of removal.

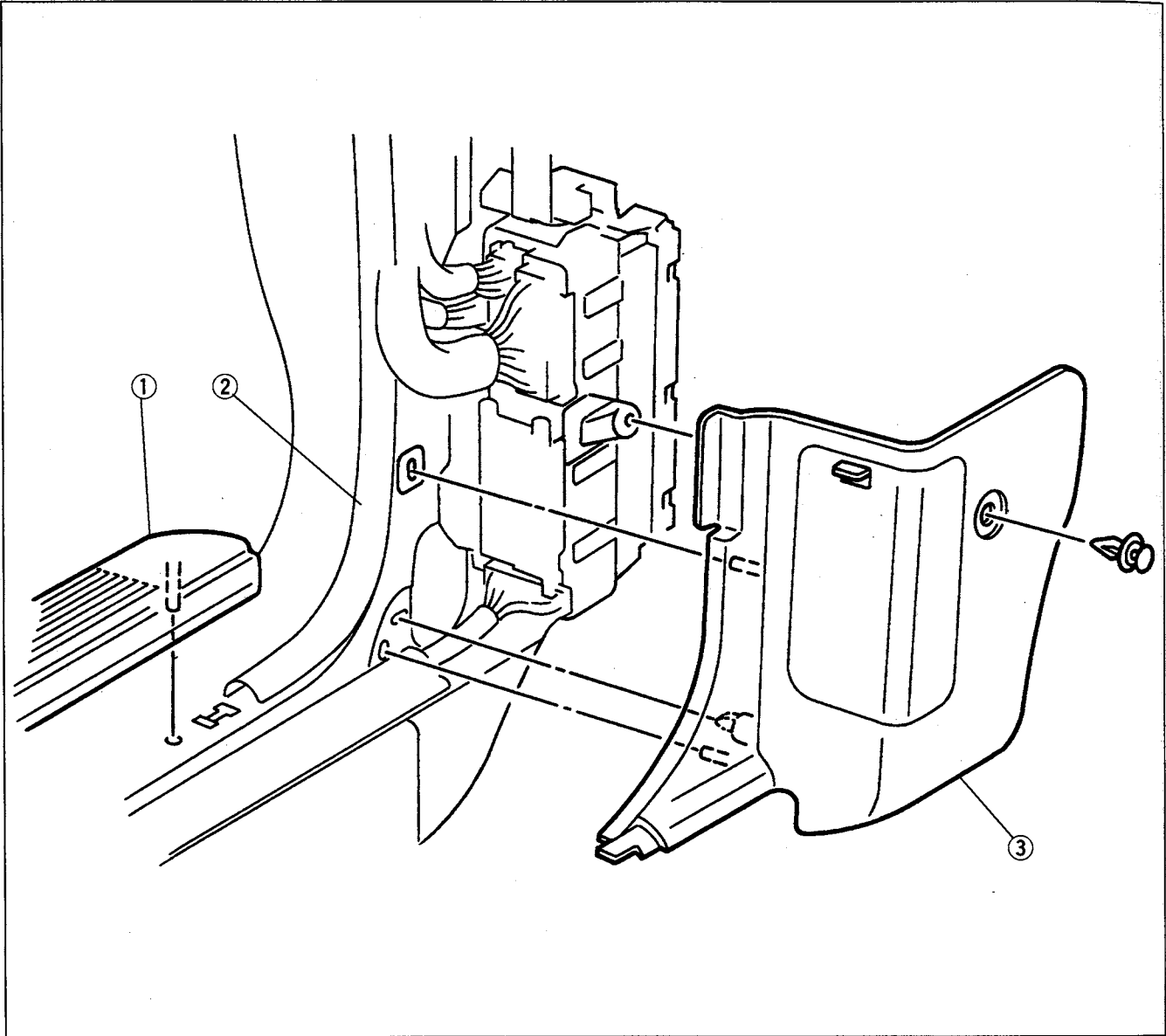

1. Front scuff plate
Removal / Installation page S1-105

2. Seaming welt
3. Front side trim
Removal note below

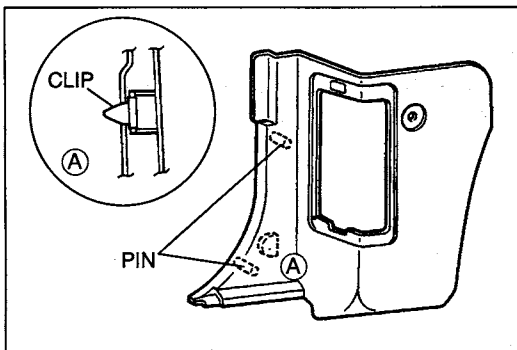

Removal note Front side trim

Pull the front side trim forward to disengage the clip and pins from the body.

FRONT SCUFF PLATE

Removal / Installation

1. Remove as shown in the figure, referring to **Removal note**.
2. Install in the reverse order of removal.

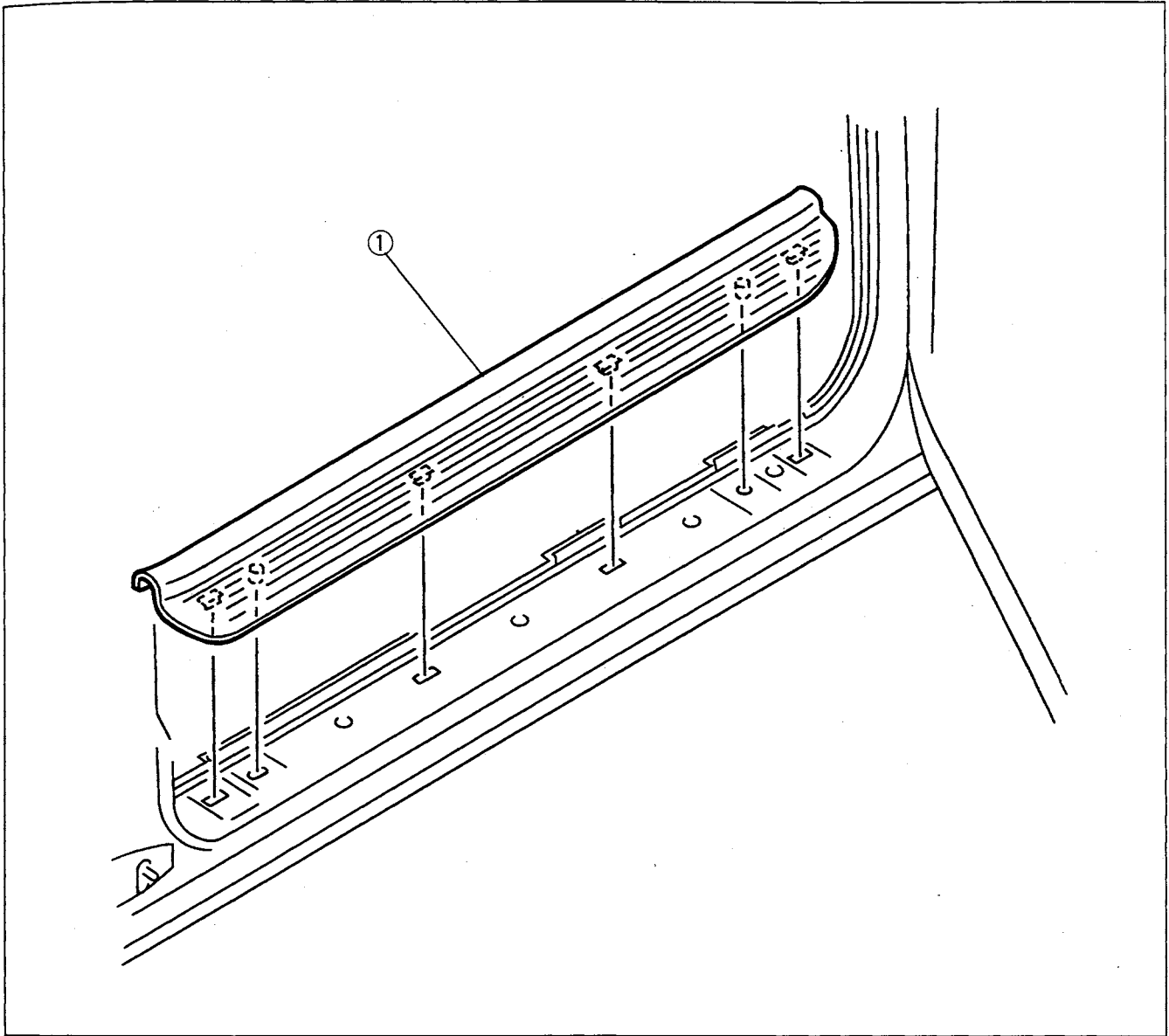

1. Front scuff plate

Removal note below

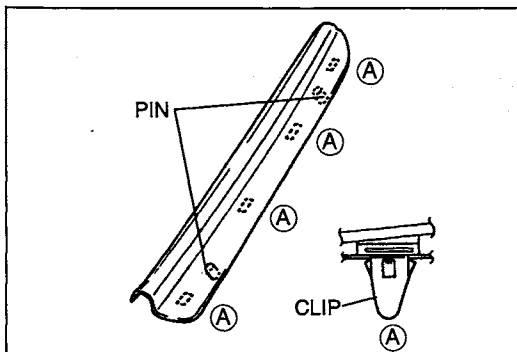

Removal note
Front scuff plate

Pull the front scuff plate upward to disengage the clips and pins from the body.

REAR SCUFF PLATE

Removal / Installation

1. Remove as shown in the figure, referring to **Removal note**.
2. Install in the reverse order of removal.

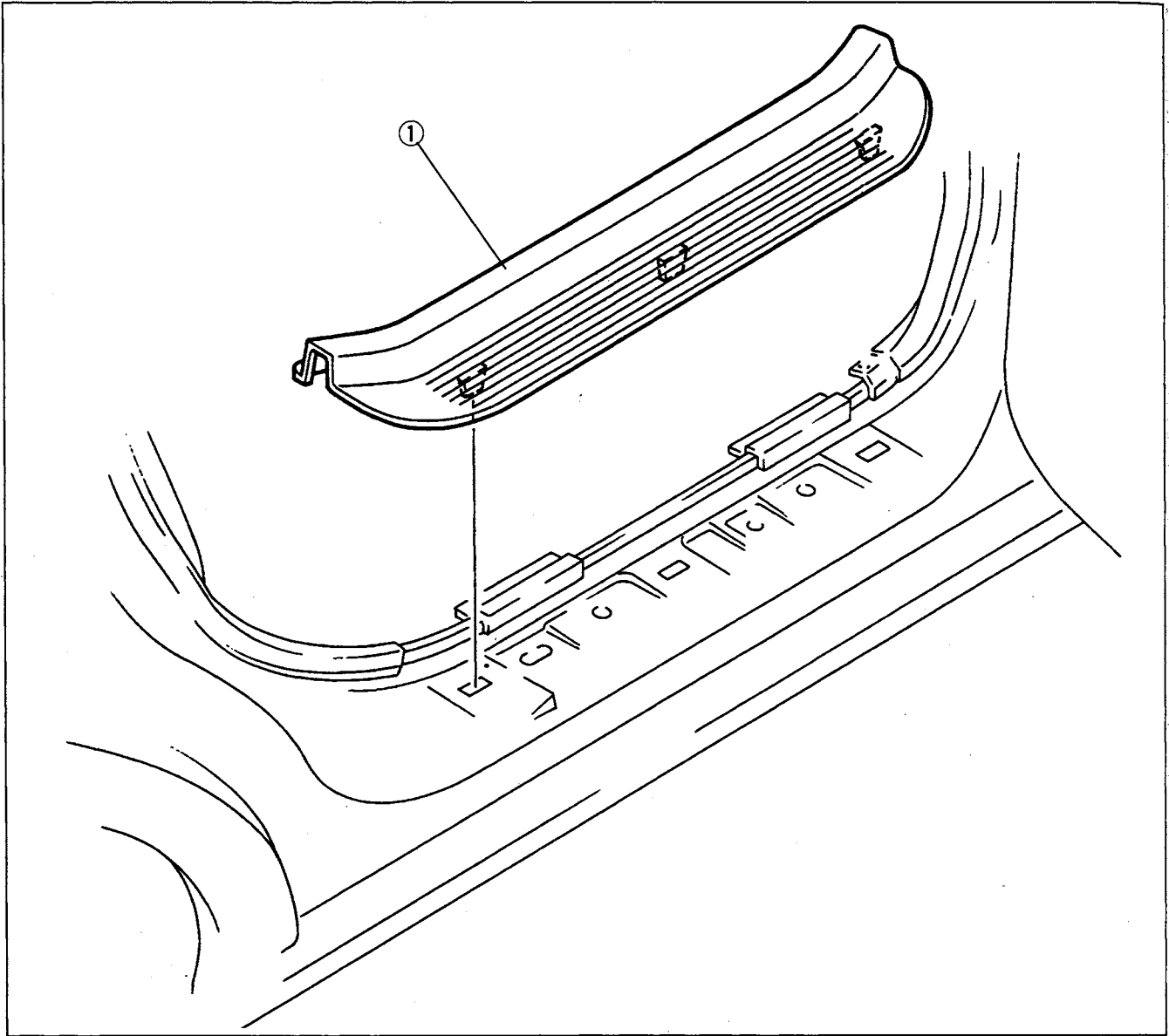

1. Rear scuff plate
Removal note below

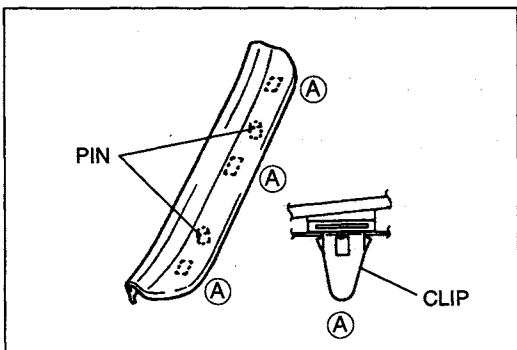

Removal note Rear scuff plate

Pull the rear scuff plate upward to disengage the clips and pins from the body.

FRONT DOOR TRIM

Removal / Installation

1. Disconnect the negative battery cable.
2. Remove in the order shown in the figure, referring to **Removal note**.
3. Install in the reverse order of removal.

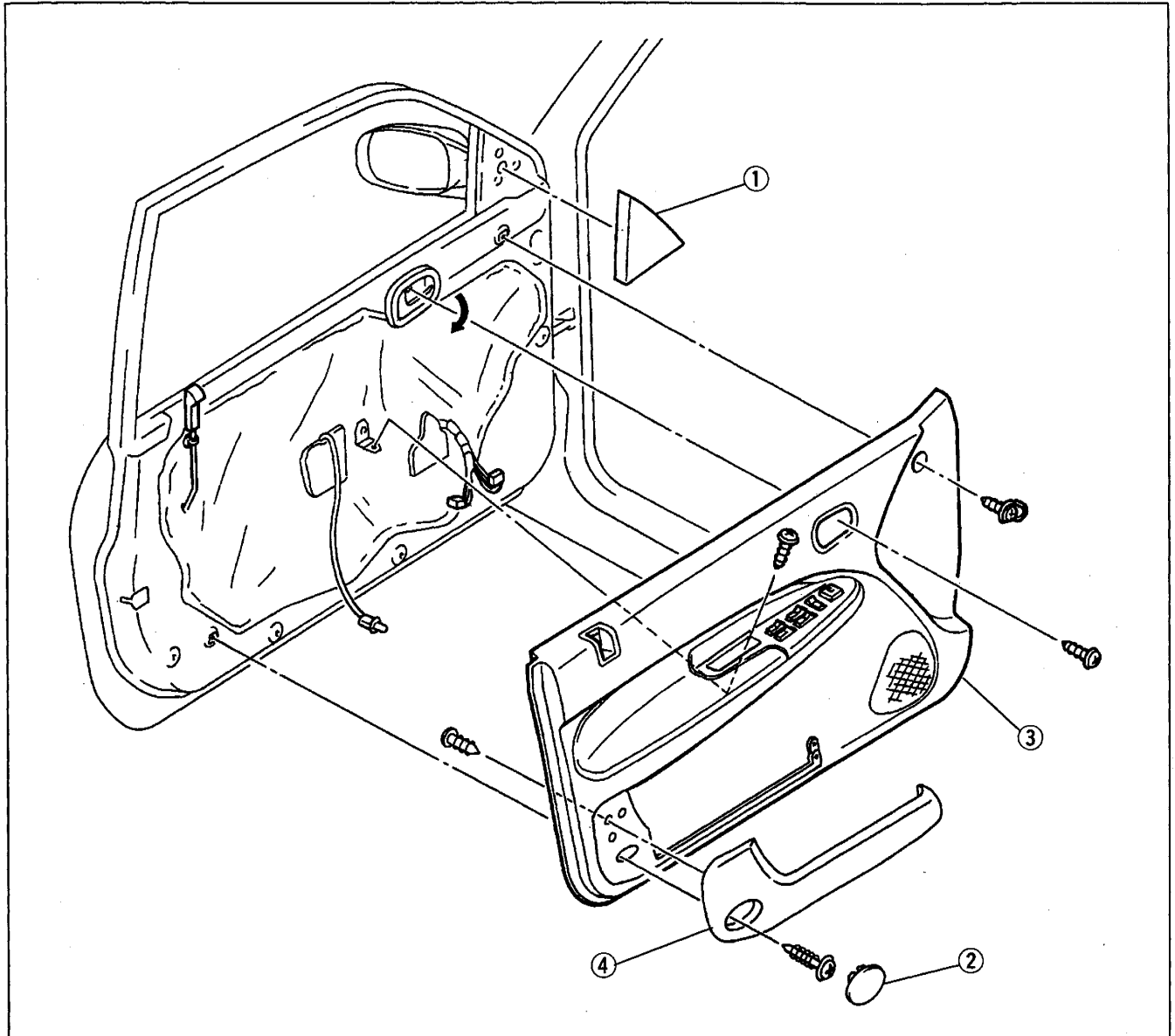

1. Inner garnish
2. Lens

3. Front door trim
Removal note below
4. Door trim pocket

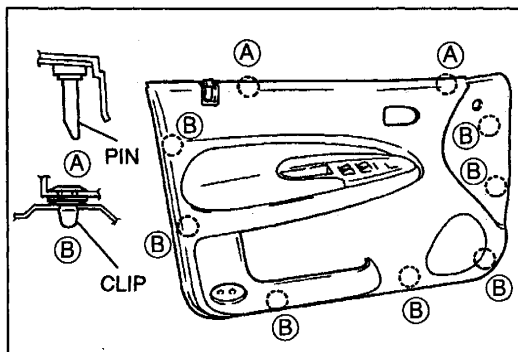

Removal note
Front door trim

1. Pull the front door trim to disengage the clips from the body.
2. Lift the front door trim to disengage the pins from the body.
3. Disconnect the harness connectors.

REAR DOOR TRIM

Removal / Installation

1. Disconnect the negative battery cable.
2. Remove in the order shown in the figure, referring to **Removal note**.
3. Install in the reverse order of removal.

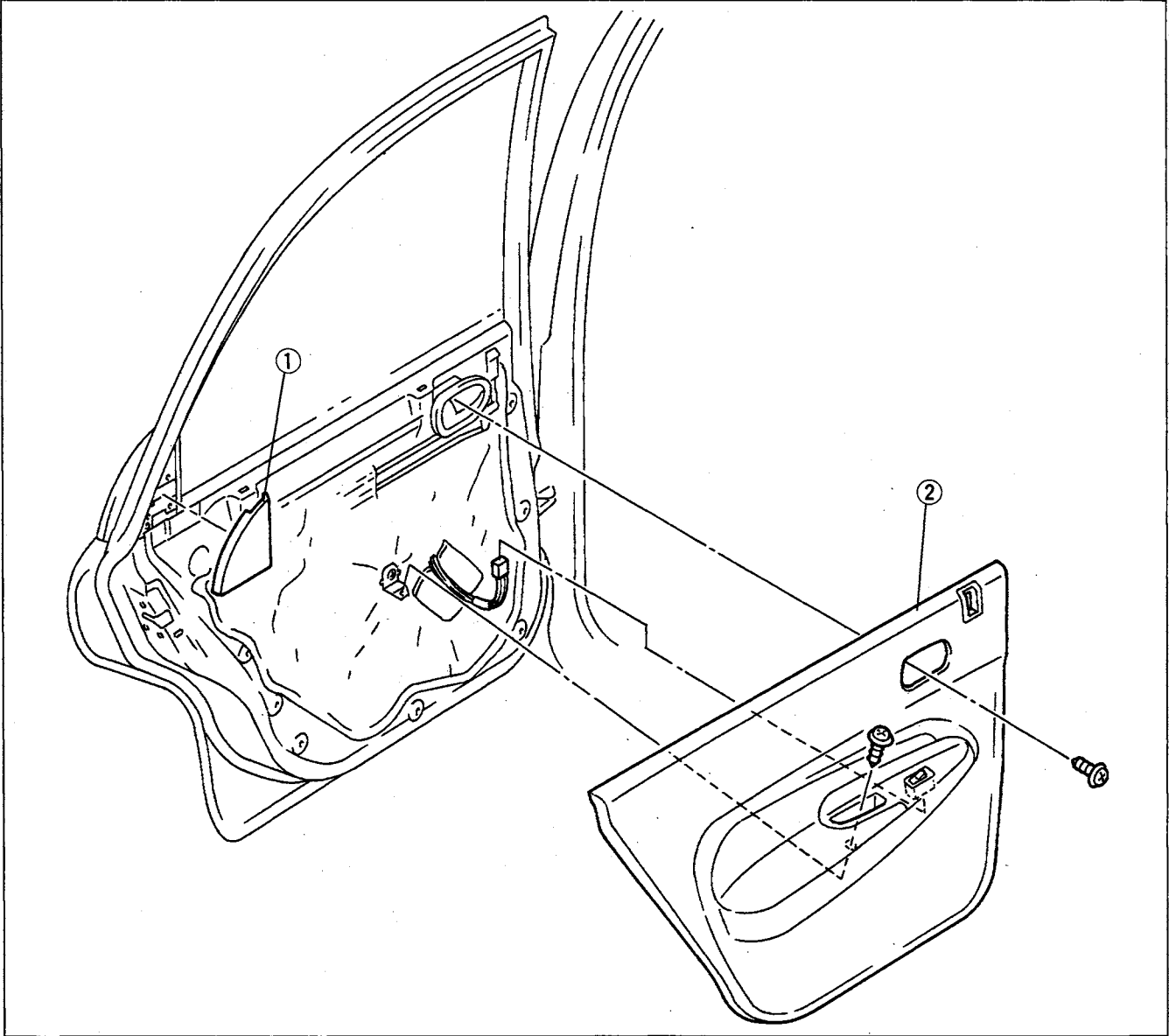

1. Inner garnish

2. Rear door trim
Removal note below

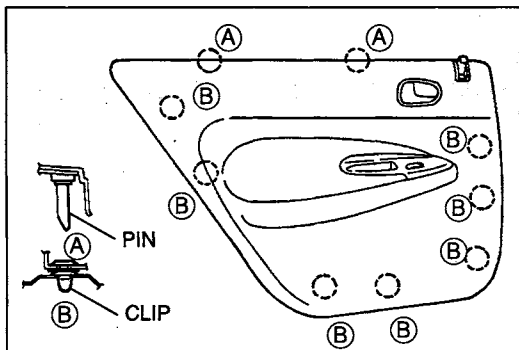

Removal note Rear door trim

1. Pull the rear door trim to disengage the clips from the body.
2. Lift the rear door trim to disengage the pins from the body.
3. Disconnect the harness connectors.

REAR PACKAGE TRIM

Removal / Installation

1. Disconnect the negative battery cable.
2. Remove the rear seat back. (Refer to pages S1-126, 129.)
3. Remove the high-mount brake light. (Refer to section T1.)
4. Remove as shown in the figure, referring to **Removal note**.
5. Install in the reverse order of removal.

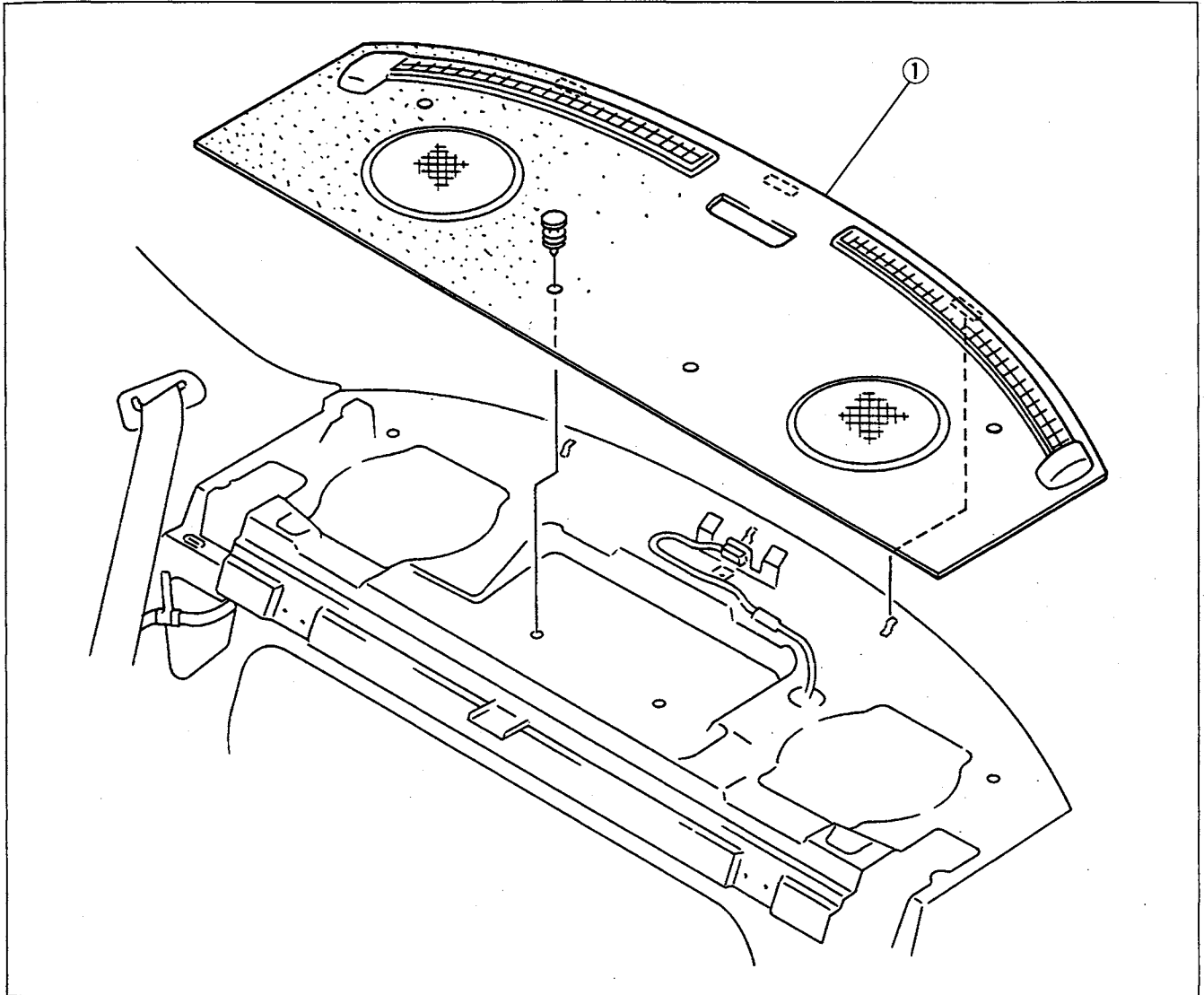

1. Rear package trim
Removal note below

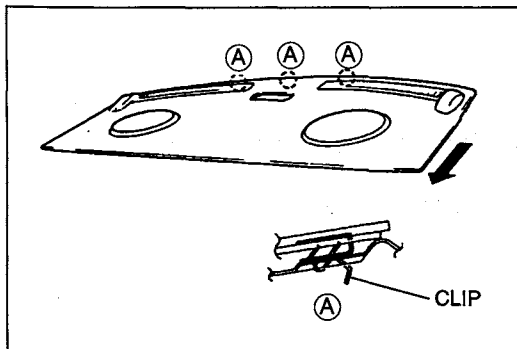

Removal note

Rear package trim

Pull the rear package trim forward to disengage the clips from the body.

REAR PACKAGE FRONT SIDE TRIM

Removal / Installation

1. Remove the rear package trim. (Refer to page S1-109.)
2. Remove the rear seat back. (Refer to pages S1-126, 129.)
3. Remove as shown in the figure.
4. Install in the reverse order of removal.

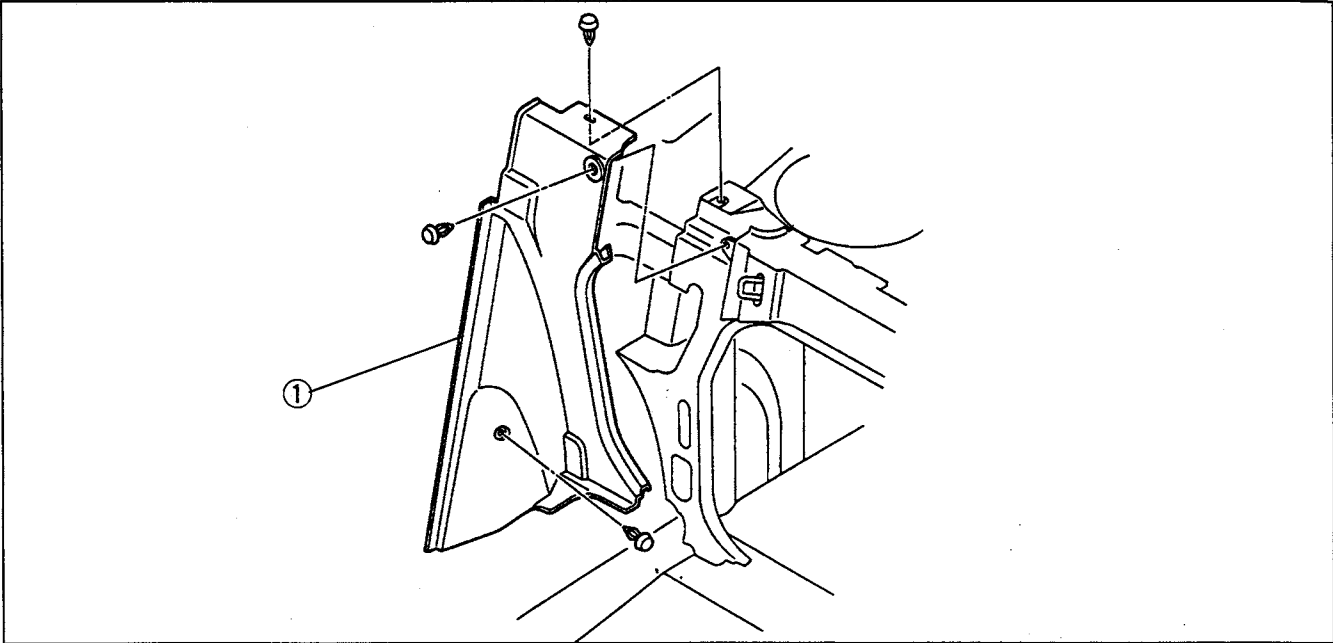

1. Rear package front side trim

REAR PACKAGE FRONT TRIM

Removal / Installation

1. Remove the rear package trim. (Refer to page S1-109.)
2. Remove in the order shown in the figure.
3. Install in the reverse order of removal.

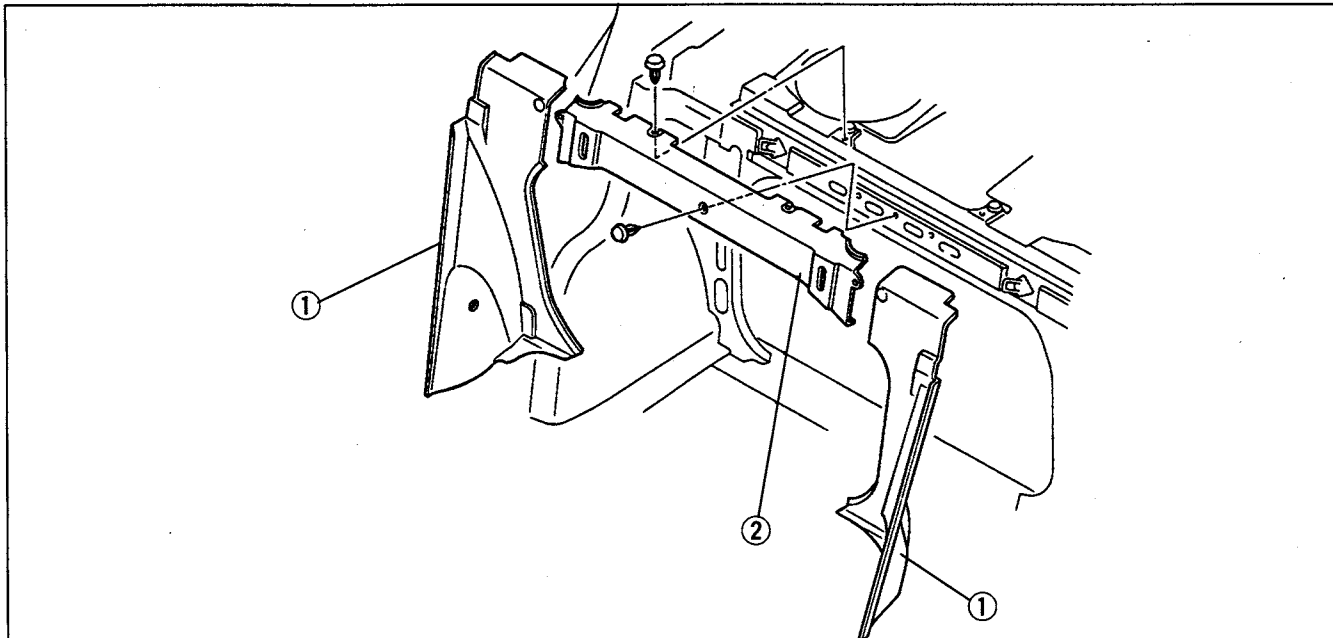

1. Rear package front side trim
Removal / Installation above
2. Rear package front trim

SEAT SIDE COMPARTMENT**Removal / Installation**

1. Remove as shown in the figure.
2. Install in the reverse order of removal.

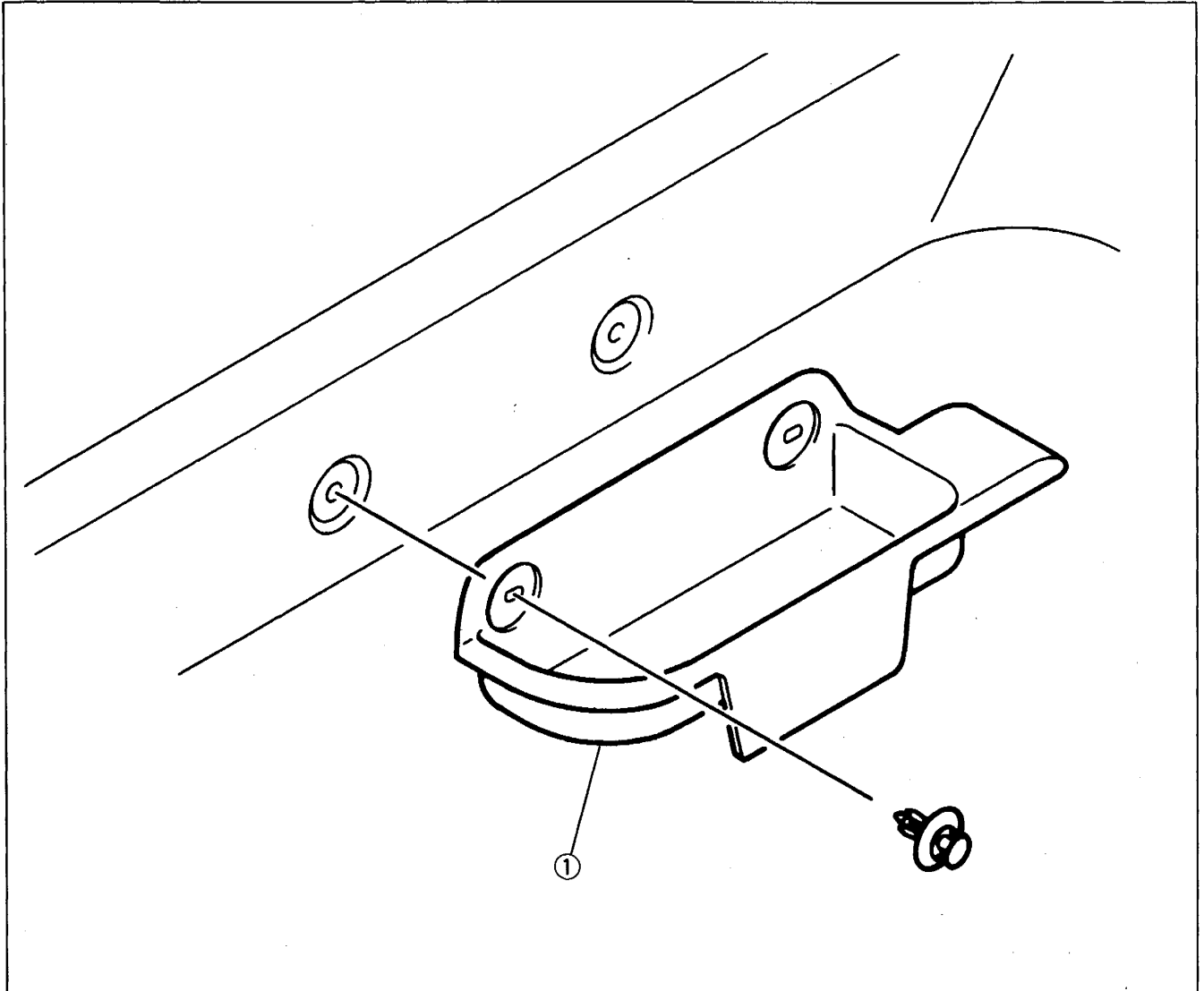

1. Seat side compartment

TRUNK END TRIM

Removal / Installation

1. Remove as shown in the figure, referring to **Removal note**.
2. Install in the reverse order of removal.

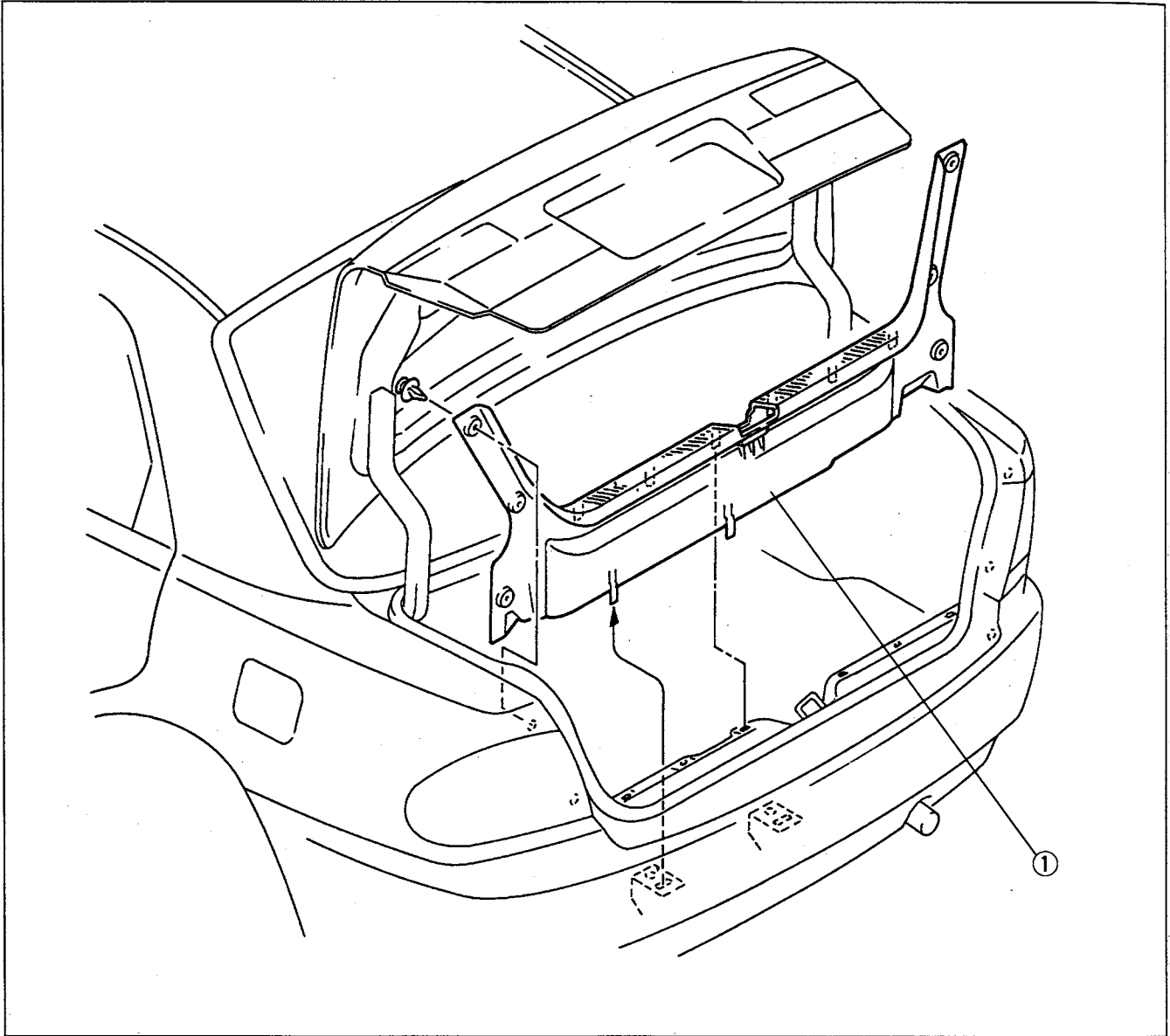

1. Trunk end trim
Removal note below

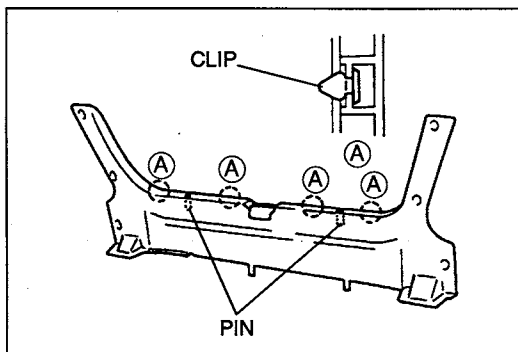

Removal note Trunk end trim

Pull the trunk end trim upward to disengage the clips and pins from the body.

TRUNK SIDE TRIM**Removal / Installation**

1. Remove the trunk end trim. (Refer to page S1-112.)
2. Remove the rear package front side trim. (Refer to page S1-110.)
3. Remove as shown in the figure.
4. Install in the reverse order of removal.

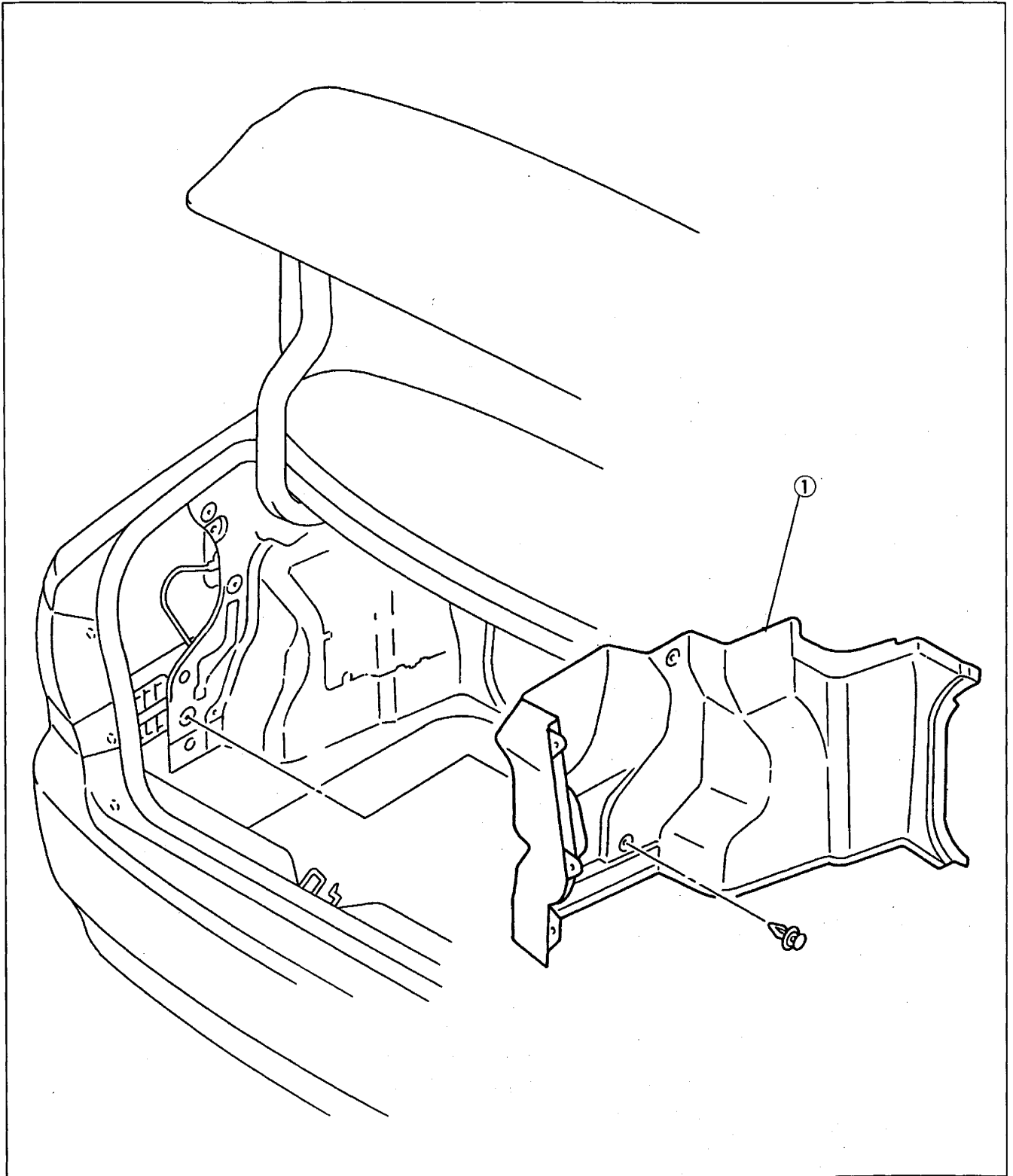

1. Trunk side trim

TRUNK LID TRIM Removal / Installation

1. Remove as shown in the figure.
2. Install in the reverse order of removal.

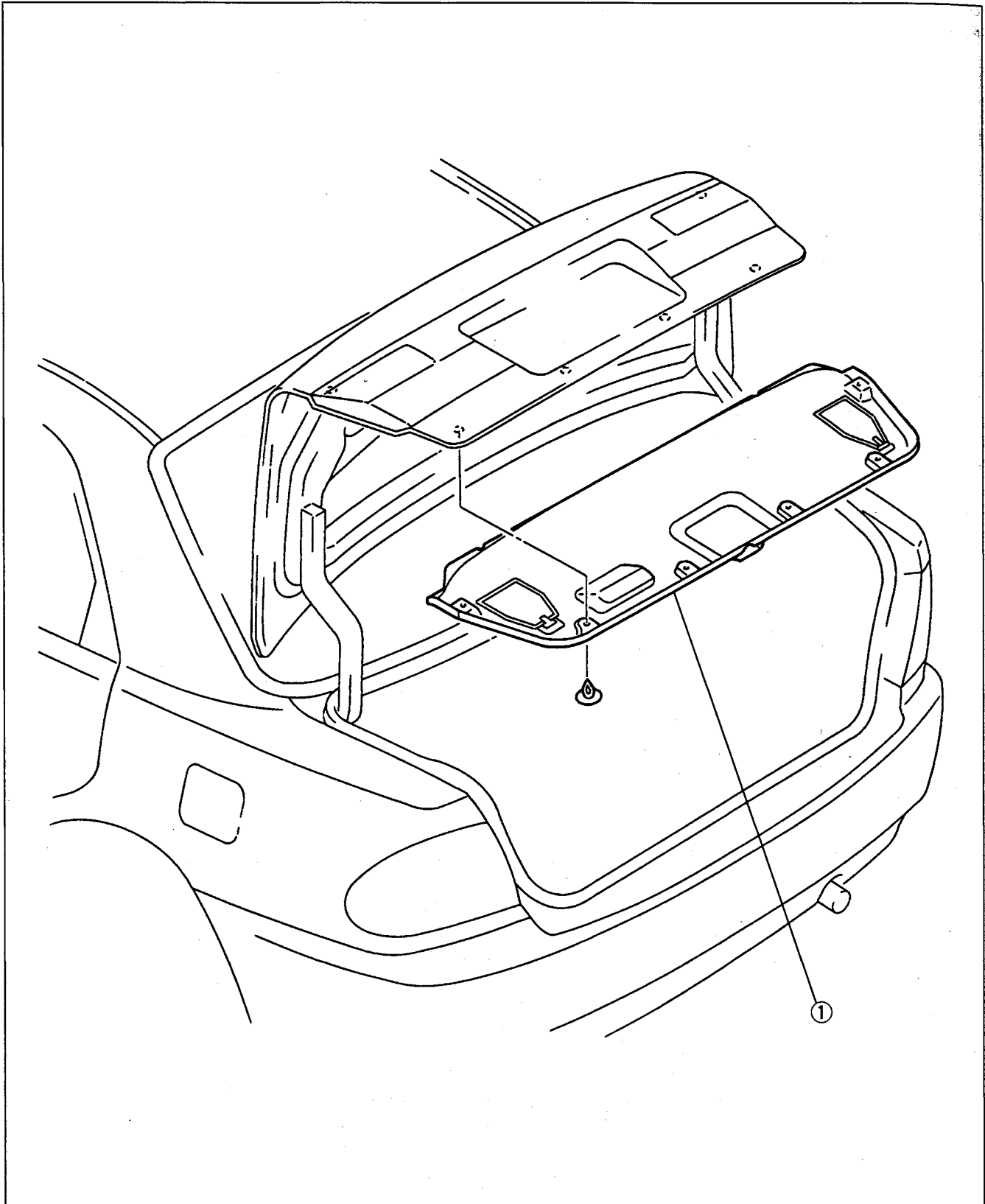

1. Trunk lid trim

FLOOR COVERING**CABIN CARPET****Removal / Installation**

1. Disconnect the negative battery cable.
2. Remove the following.
 - a. Dashboard and console (Refer to page S1-84.)
 - b. Front seat (Refer to page S1-121.)
 - c. Rear seat (Refer to page S1-126.)
 - d. B-pillar lower trim (Refer to page S1-101.)
 - e. Front seat belt lower anchor. (Refer to page S1-117.)
3. Remove in the order shown in the figure.
4. Install in the reverse order of removal.

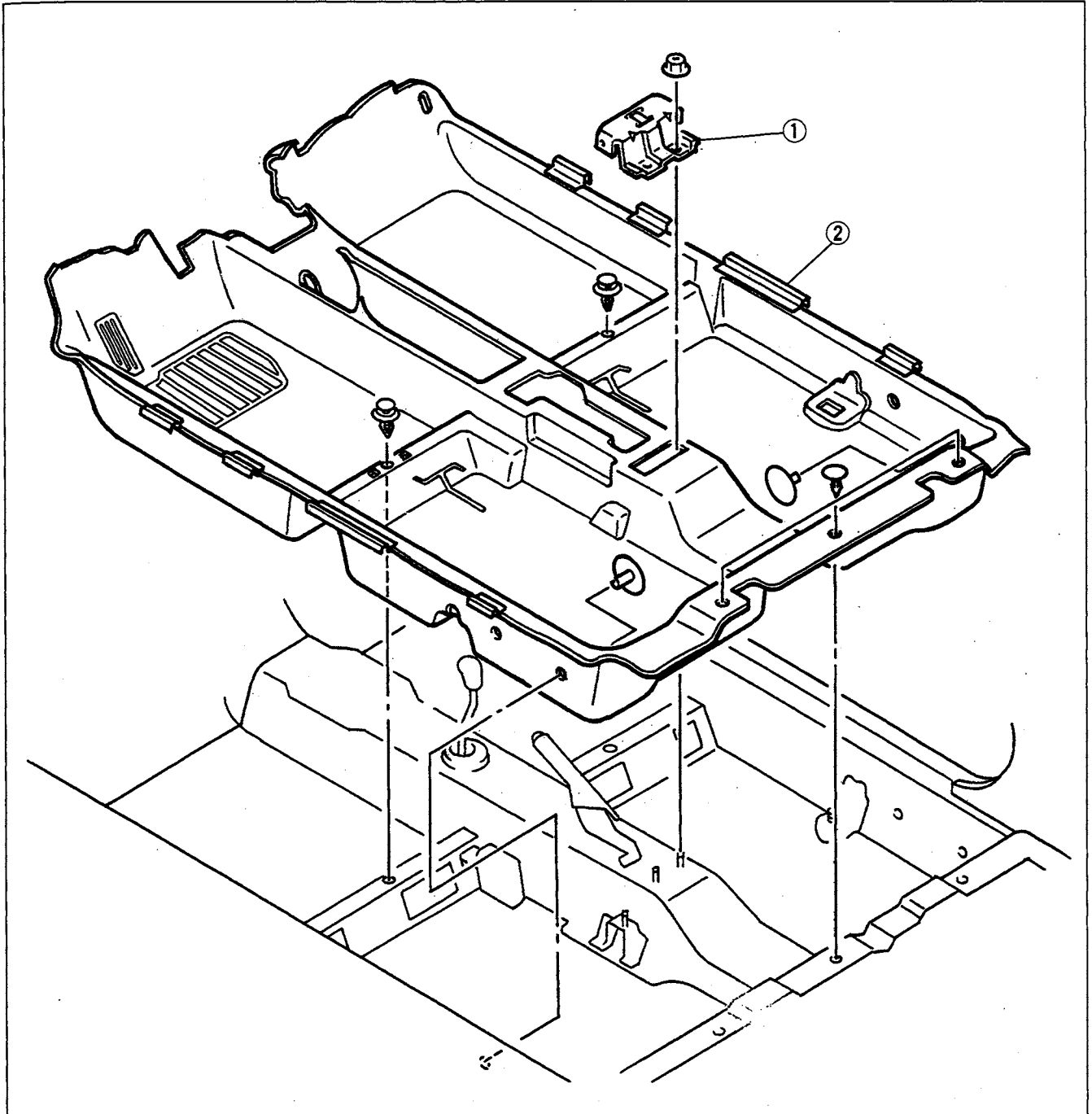

1. Rear console bracket

2. Cabin carpet

HEADLINER

HEADLINER

Removal / Installation

1. Disconnect the negative battery cable.
2. Remove the A-pillar trim (Refer to page S1-100.), B-pillar upper trim (Refer to page S1-102.), and C-pillar trim (Refer to page S1-103.).
3. Remove in the order shown in the figure.
4. Install in the reverse order of removal.

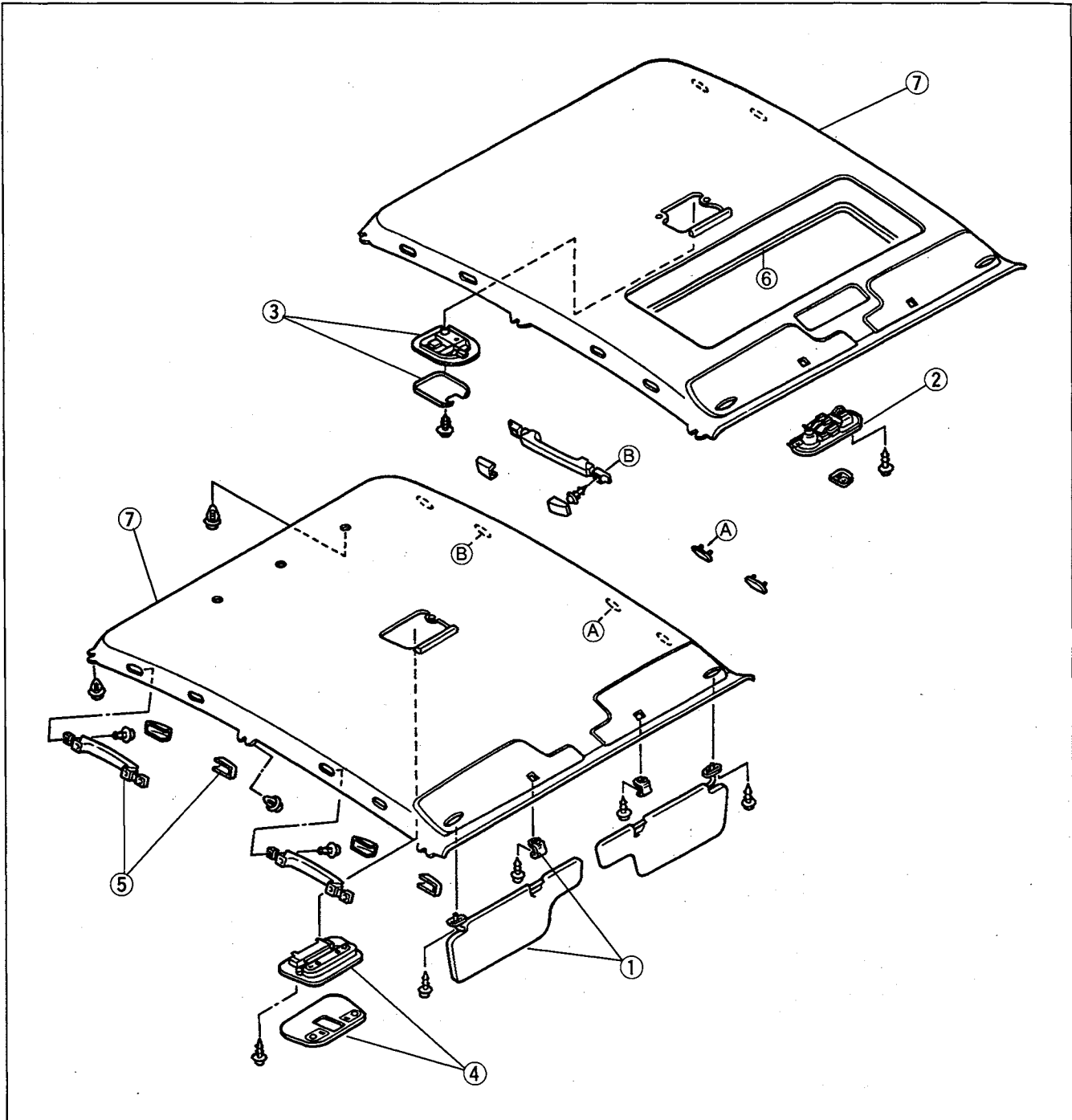

- | | |
|--|-----------------------------------|
| 1. Sunvisor and adapter | 5. Assist handle |
| 2. Overhead console (sliding sunroof) | 6. Seaming welt (sliding sunroof) |
| 3. Room light (sliding sunroof) | 7. Headliner |
| 4. Room and spot light (without sliding sunroof) | |

SEAT BELT

FRONT SEAT BELT
Removal / Installation

Caution

- The ELR (emergency locking retractor) has a spring that will unwind if the retractor's cover is removed. The spring cannot be rewound by hand. If this occurs, the ELR will not work properly. Therefore, do not disassemble the retractor.

1. Disconnect the negative battery cable.
2. Remove in the order shown in the figure. To remove the front seat belt, remove the B-pillar lower trim. (Refer to page S1-101.) To remove the anchor adjuster, remove the B-pillar upper trim. (Refer to page S1-102.)
3. Install in the reverse order of removal.

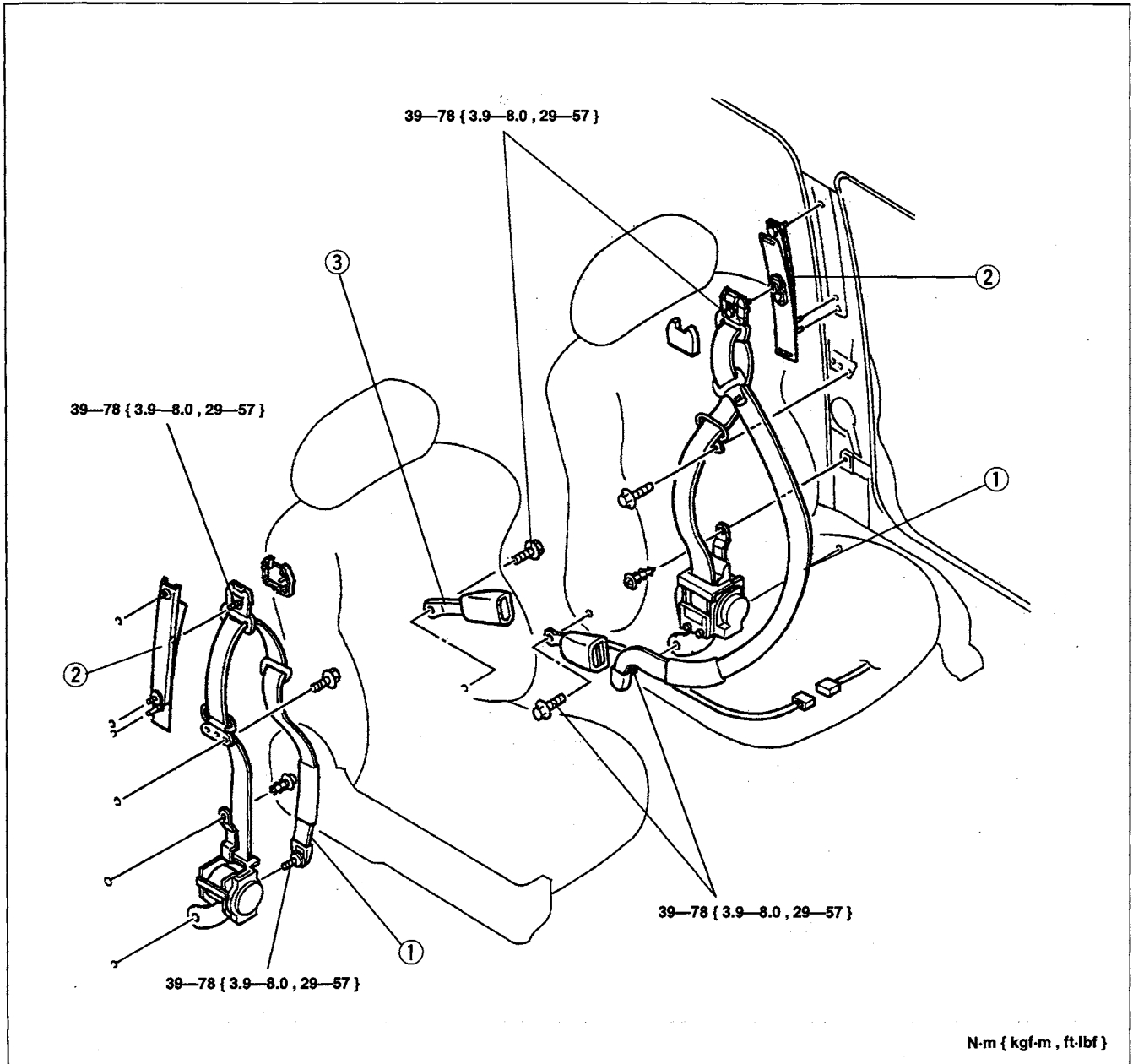

N·m { kgf·m , ft·lbf }

1. Front seat belt
Inspection page S1-118

2. Anchor adjuster
3. Front buckle

Inspection

Seat belt

1. Inspect the webbing for scars, tears, and wear.
2. Inspect the fittings for deformation and damage.
3. If a problem is found, replace the front seat belt.

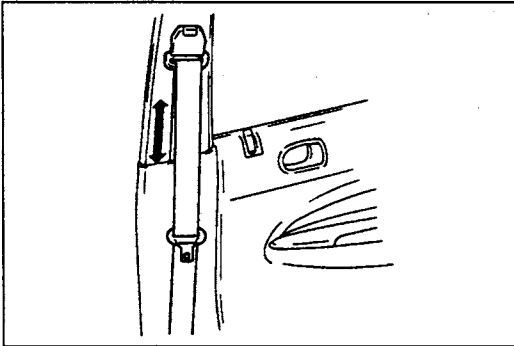

ELR (emergency locking retractor)

1. Verify that the belt can be pulled out smoothly, and that it moves smoothly when worn.
2. Verify that the retractor locks when the belt is quickly pulled.

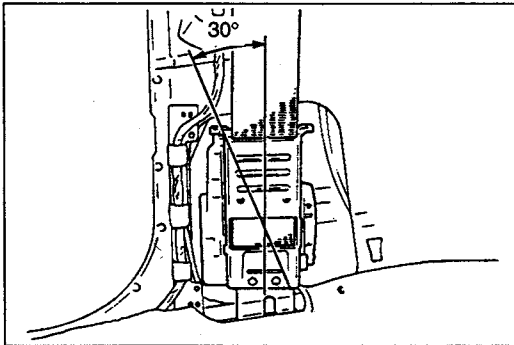

3. Remove the retractor. (Refer to page S1-117.)
4. Hold the retractor as it would be installed.
5. Slowly incline the retractor while pulling out the belt.
6. Verify that the retractor locks at approximately 30° inclination.
7. If not as specified, replace the front seat belt.

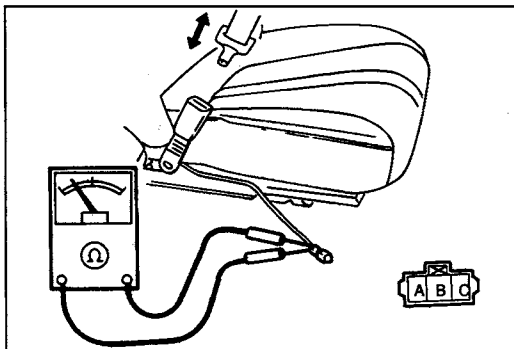

FRONT BUCKLE

Inspection

1. Disconnect the buckle switch connector.
2. Check for continuity between the connector terminals.

Terminal	Driver	
	A	B
Seat belt		
Buckled		
Unbuckled	○ — ○	○ — ○

○ — ○: Continuity

3. If not as specified, replace the front buckle.

REAR SEAT BELT
Removal / Installation

Caution

- The ELR (emergency locking retractor) has a spring that will unwind if the retractor's cover is removed. The spring cannot be rewound by hand. If this occurs, the ELR will not work properly. Therefore, do not disassemble the retractor.

1. Remove the rear seat cushion. (Refer to pages S1-126, 129.)
2. Remove in the order shown in the figure. To remove the rear seat belt, remove the C-pillar trim (Refer to page S1-103.) and trunk side trim (Refer to page S1-113.)
3. Install in the reverse order of removal.

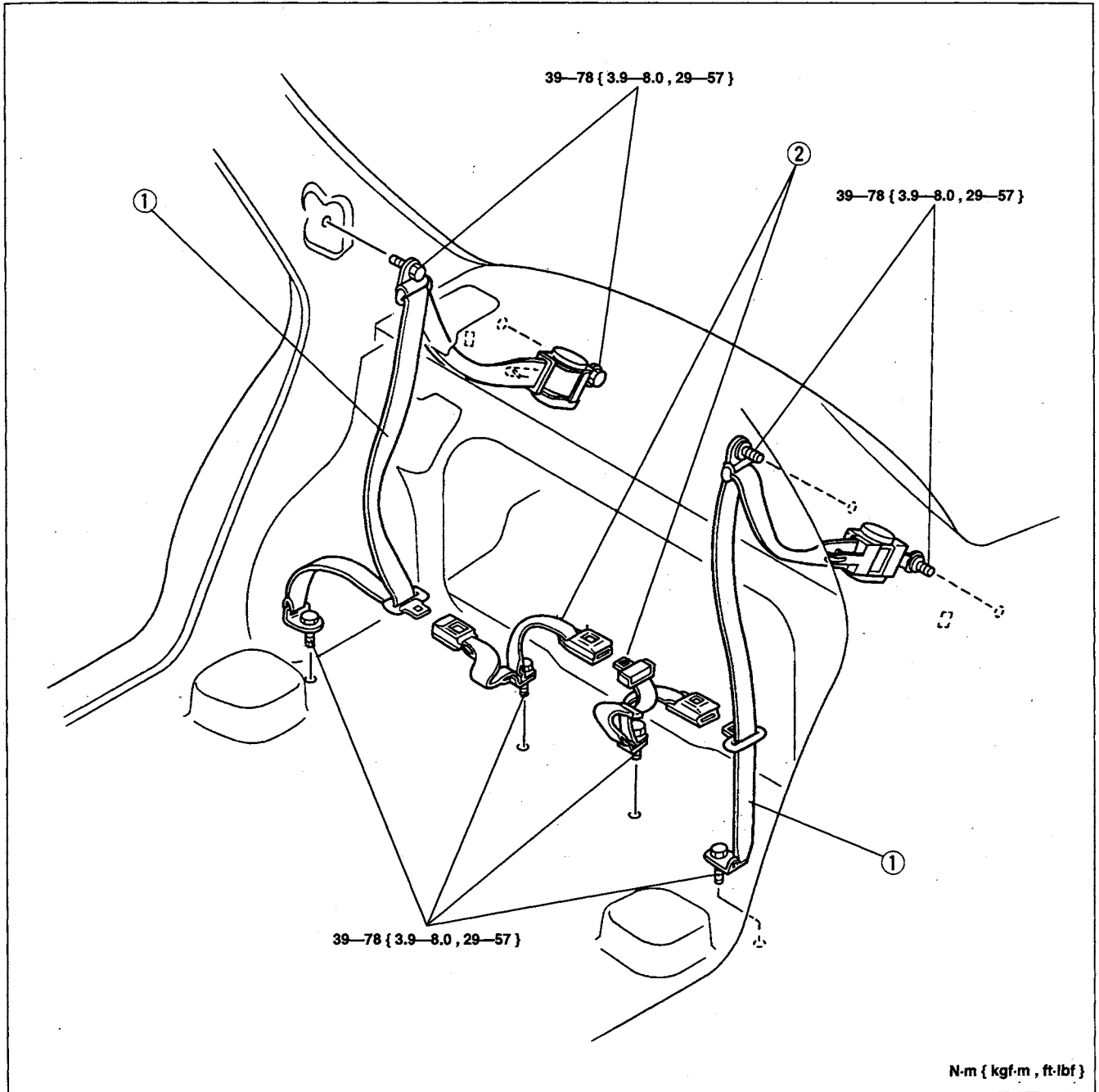

1. Rear seat belt
Inspection page S1-120

2. Rear buckle

Inspection**Seat belt**

1. Inspect the webbing for scars, tears, and wear.
2. Inspect the fittings for deformation and damage.
3. If a problem is found, replace the rear seat belt.

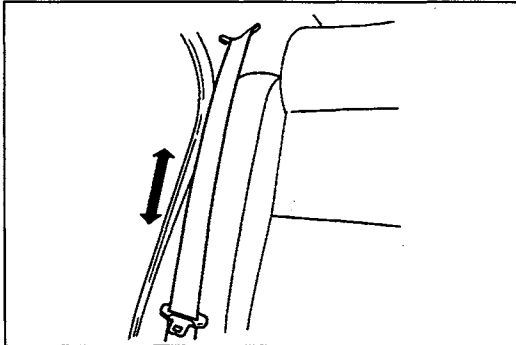
**ELR (emergency locking retractor)**

1. Verify that the belt can be pulled out smoothly, and that it moves smoothly when worn.
2. Verify that the retractor locks when the belt is quickly pulled.

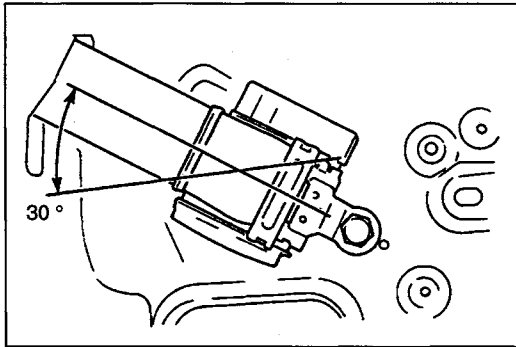

3. Remove the retractor. (Refer to page S1-119.)
4. Hold the retractor as it would be installed.
5. Slowly incline the retractor while pulling out the belt.
6. Verify that the retractor locks at approximately 30° inclination.
7. If not as specified, replace the rear seat belt.

SEAT

FRONT SEAT

Removal / Installation

1. Disconnect the negative battery cable.
2. Remove in the order shown in the figure.
3. Install in the reverse order of removal.

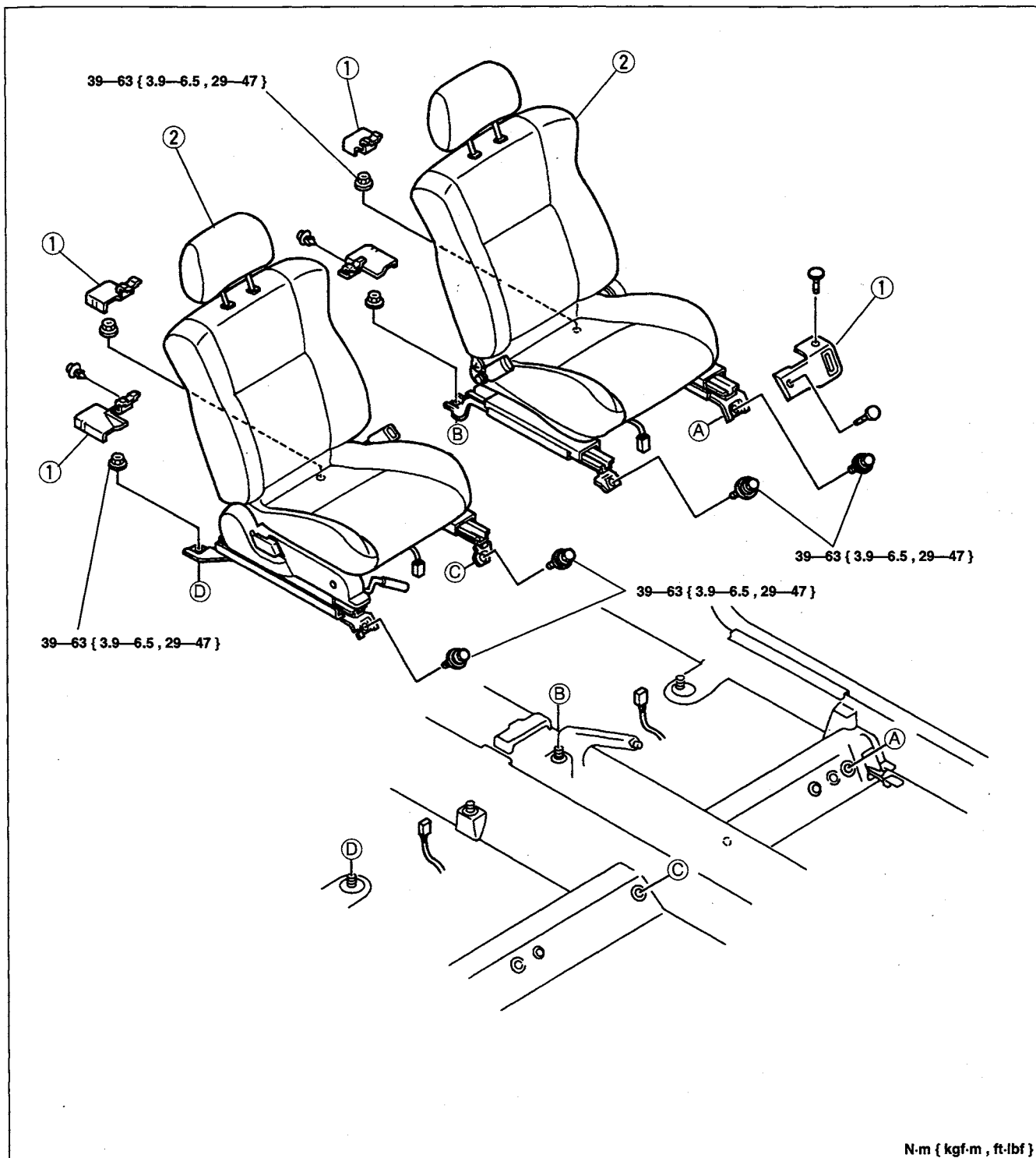

1. Adjuster cover

2. Front seat
Disassembly / Assembly page S1-122

Disassembly / Assembly

1. Disassemble in the order shown in the figure, referring to **Disassembly note**.
2. Assemble in the reverse order of disassembly.

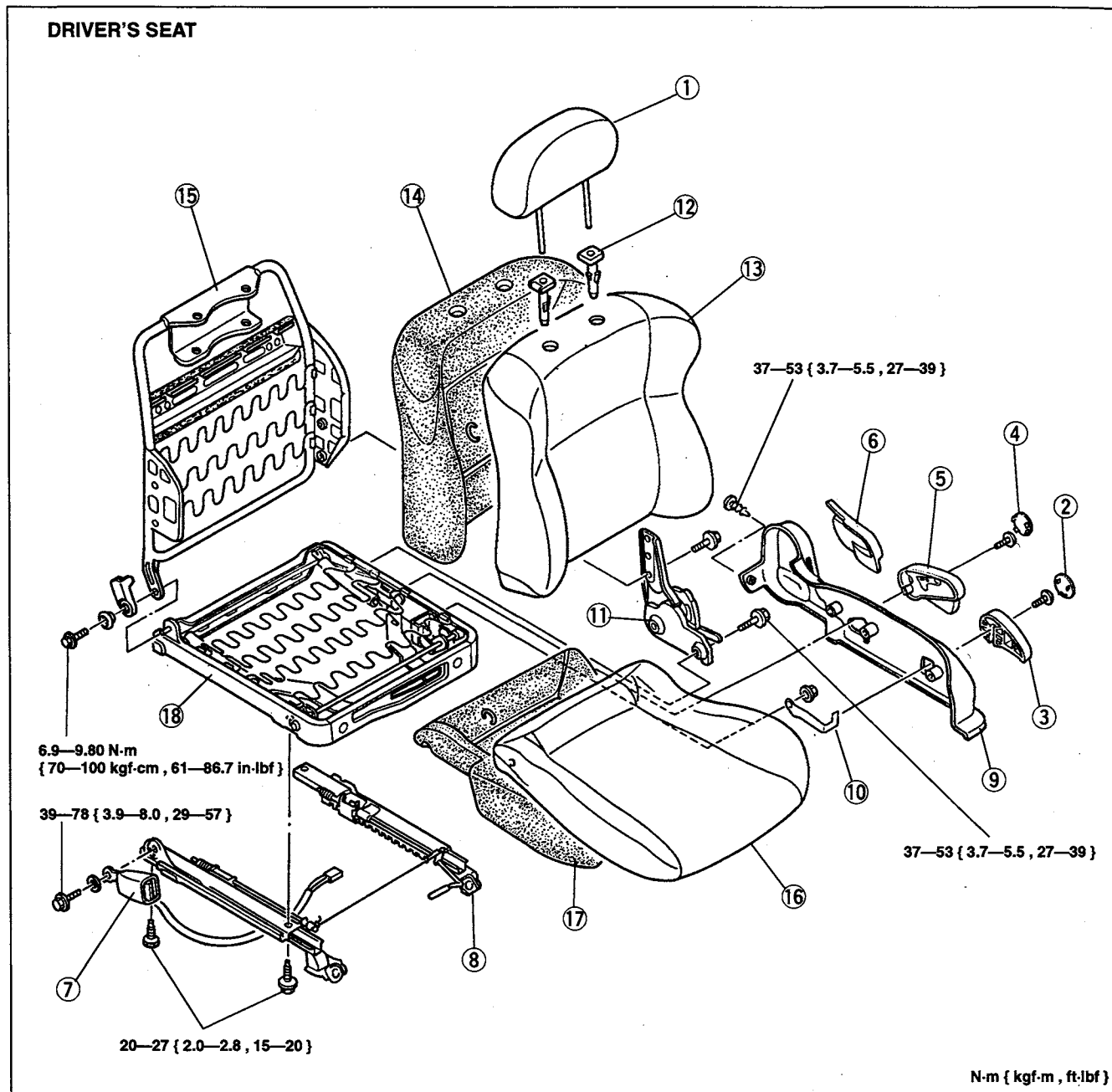

1. Headrest
2. Front-lift knob cap
3. Front-lift knob
4. Rear-lift knob cap
5. Rear-lift knob
6. Recliner knob
7. Front buckle
8. Slide adjuster
9. Seat side cover
10. Front-lift lever
11. Recliner knuckle

12. Pole guide
Disassembly note page S1-124
13. Seat back trim
Disassembly note page S1-124
14. Seat back pad
15. Seat back frame
16. Seat cushion trim
Disassembly note page S1-124
17. Seat cushion pad
18. Seat cushion frame

PASSENGER'S SEAT

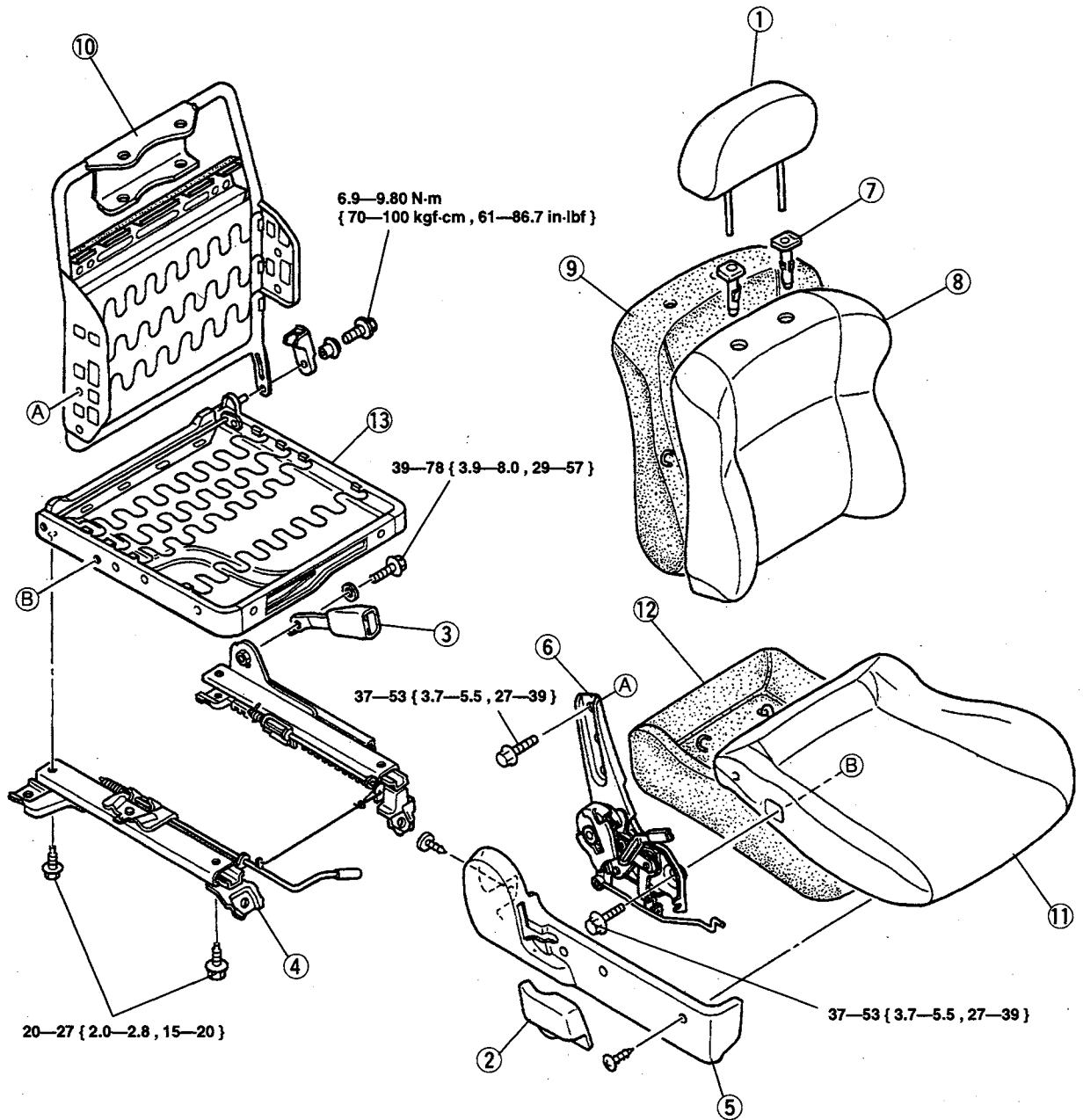

N-m { kgf-m , ft-lbf }

- | | |
|------------------------------------|------------------------------------|
| 1. Headrest | 8. Seat back trim |
| 2. Recliner knob | Disassembly note page S1-124 |
| 3. Front buckle | 9. Seat back pad |
| 4. Slide adjuster | 10. Seat back frame |
| 5. Seat side cover | 11. Seat cushion trim |
| 6. Recliner knuckle | Disassembly note page S1-124 |
| 7. Pole guide | 12. Seat cushion pad |
| Disassembly note page S1-124 | 13. Seat cushion frame |

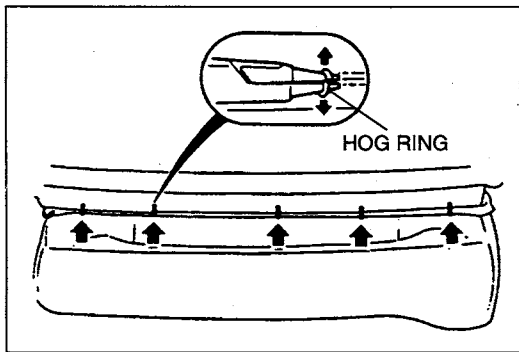

Disassembly note
Pole guide, seat back trim

1. Remove the hog rings under the seat back trim.

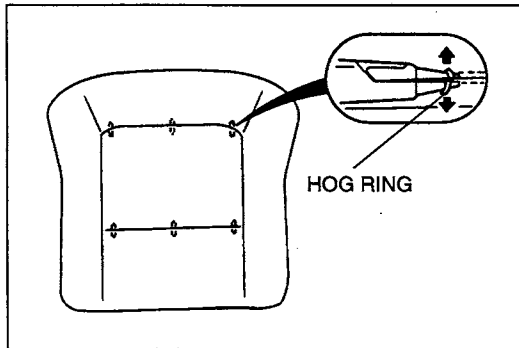

2. Turn up the seat back trim and remove the hog rings holding the trim to the pad.

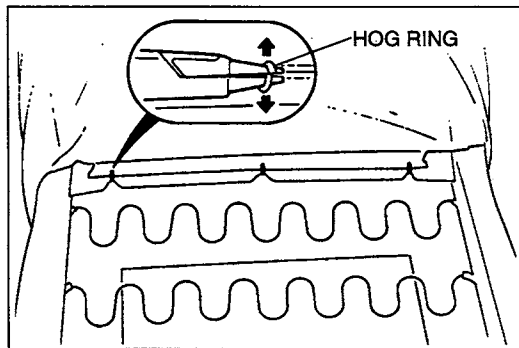

3. Turn up the seat back trim and remove the hog rings holding the trim to the frame.

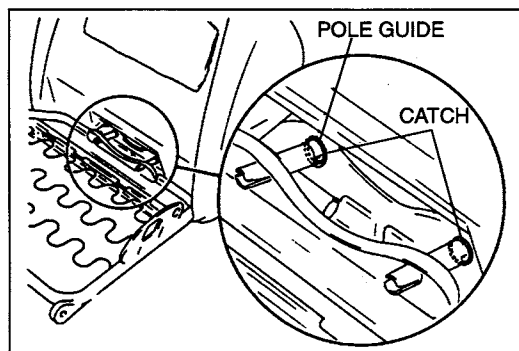

4. Squeeze the catches on the pole guide by using pliers to remove the pole guide.

5. Remove the seat back trim.

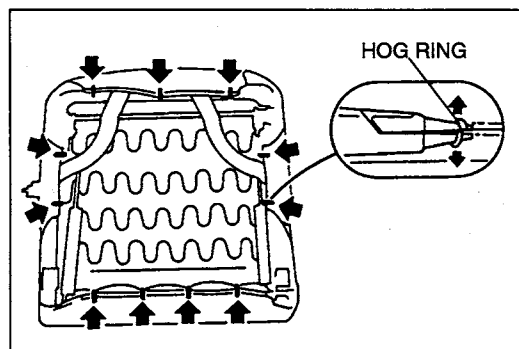

Seat cushion trim

1. Remove the hog rings holding the trim to the frame.

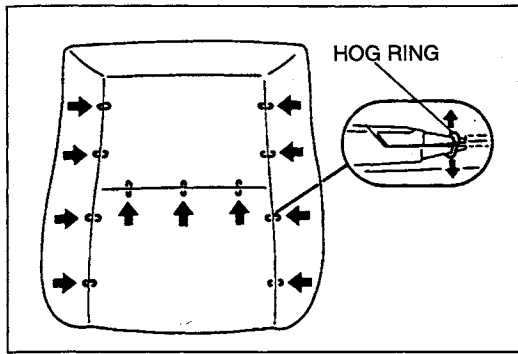

2. Turn up the seat cushion trim and remove the hog rings holding the trim to the pad.

REAR SEAT Removal / Installation

1. Remove in the order shown in the figure.
2. Install in the reverse order of removal.

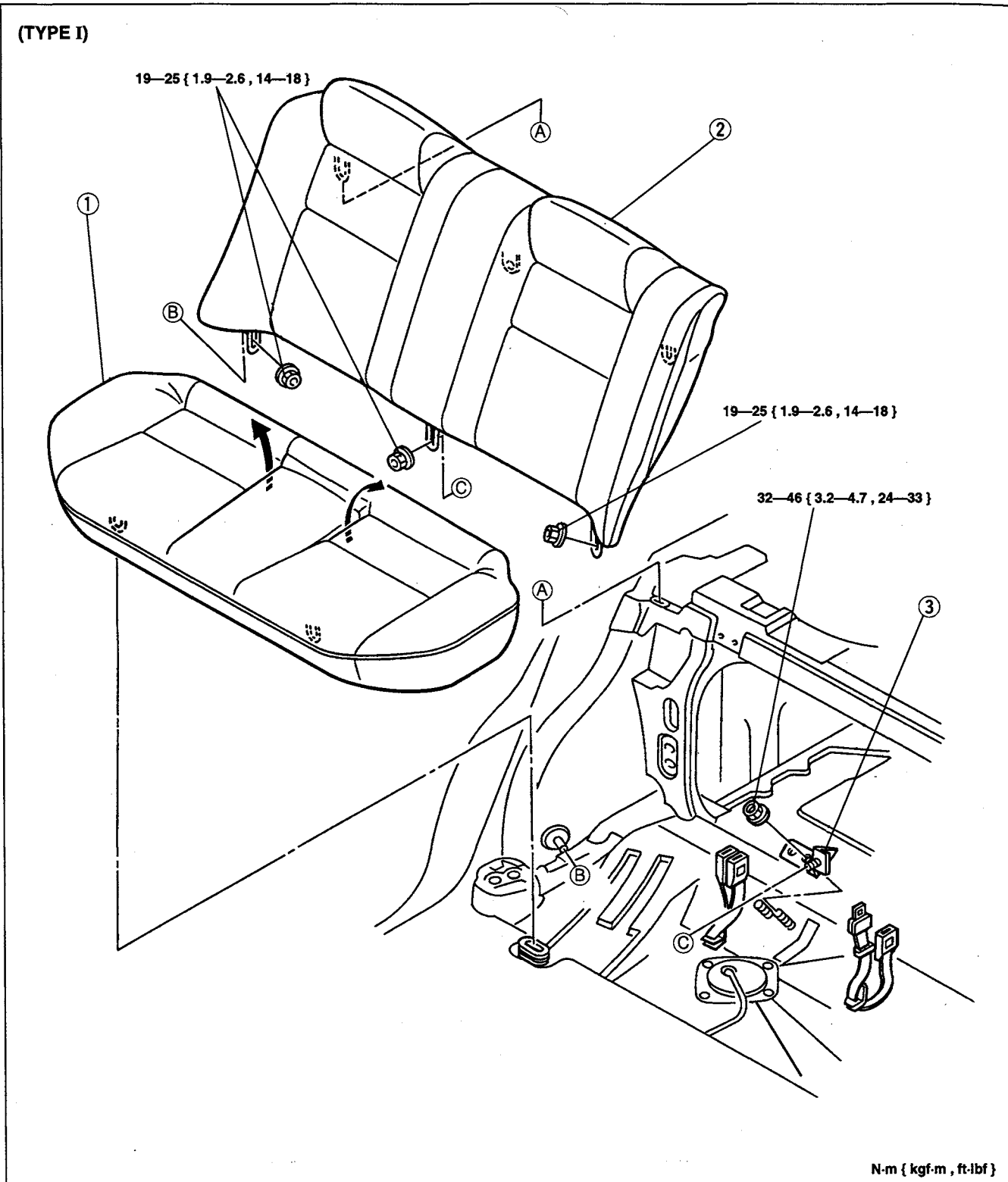

1. Rear seat cushion
Disassembly / Assembly page S1-127

2. Rear seat back
Disassembly / Assembly page S1-127

3. Rear seat back hinge

Disassembly / Assembly

1. Disassemble in the order shown in the figure, referring to **Disassembly note**.
2. Assemble in the reverse order of disassembly.

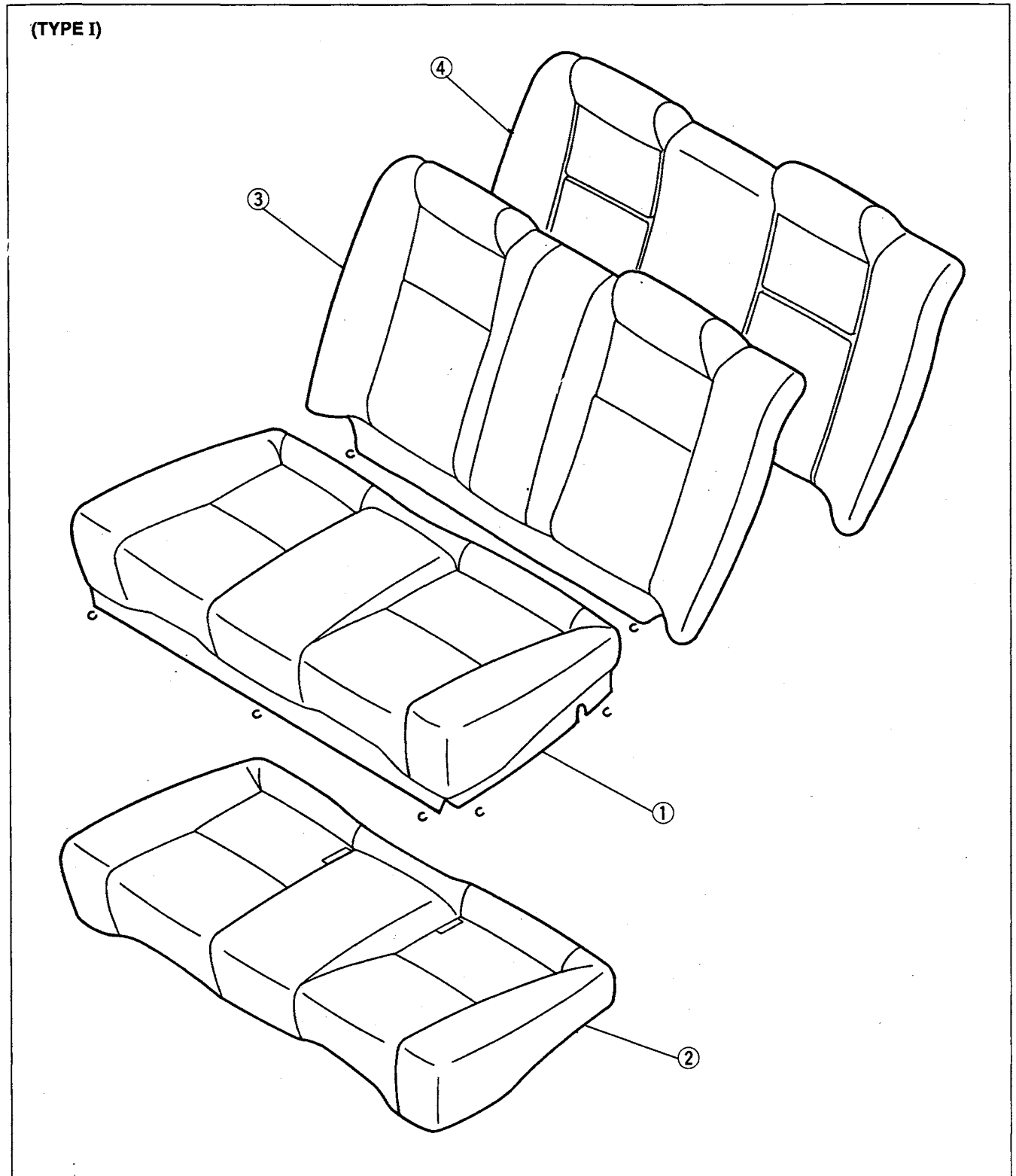

Rear seat cushion

1. Rear seat cushion trim
Disassembly note page S1-128
2. Rear seat cushion pad

Rear seat back

3. Rear seat back trim
Disassembly note page S1-128
4. Rear seat back pad

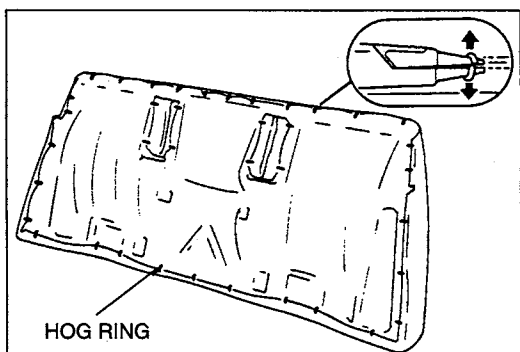

Disassembly note

Rear seat cushion trim

1. Remove the hog rings under the rear seat cushion trim.

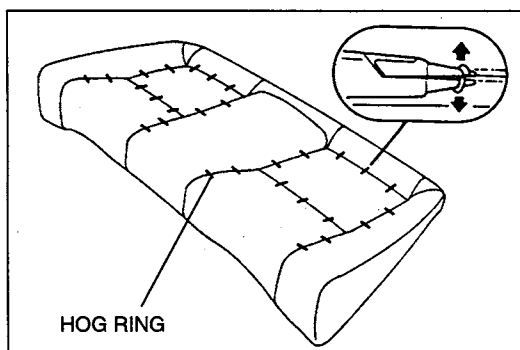

2. Turn up the rear seat cushion trim and remove the hog rings holding the trim to the pad.

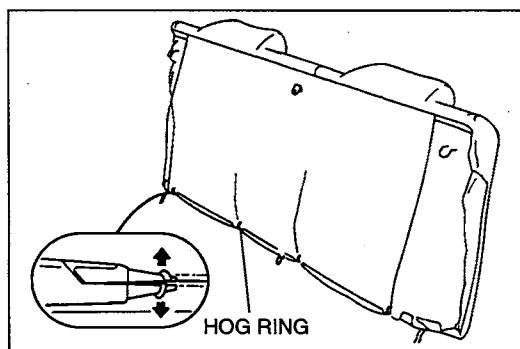

Rear seat back trim

1. Remove the hog rings on the back of the rear seat back trim.

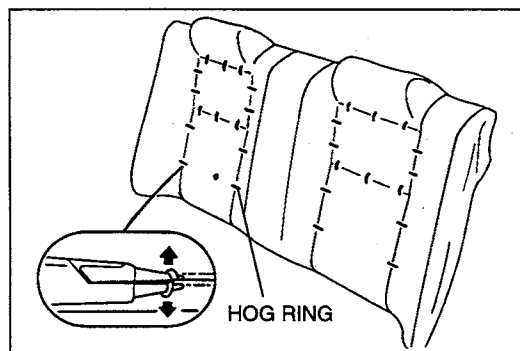

2. Turn up the rear seat back trim and remove the hog rings holding the trim to the pad.

Removal / Installation

1. Remove in the order shown in the figure. To remove the rear seat back striker, remove the rear package front trim. (Refer to page S1-110.)
2. Install in the reverse order of removal.

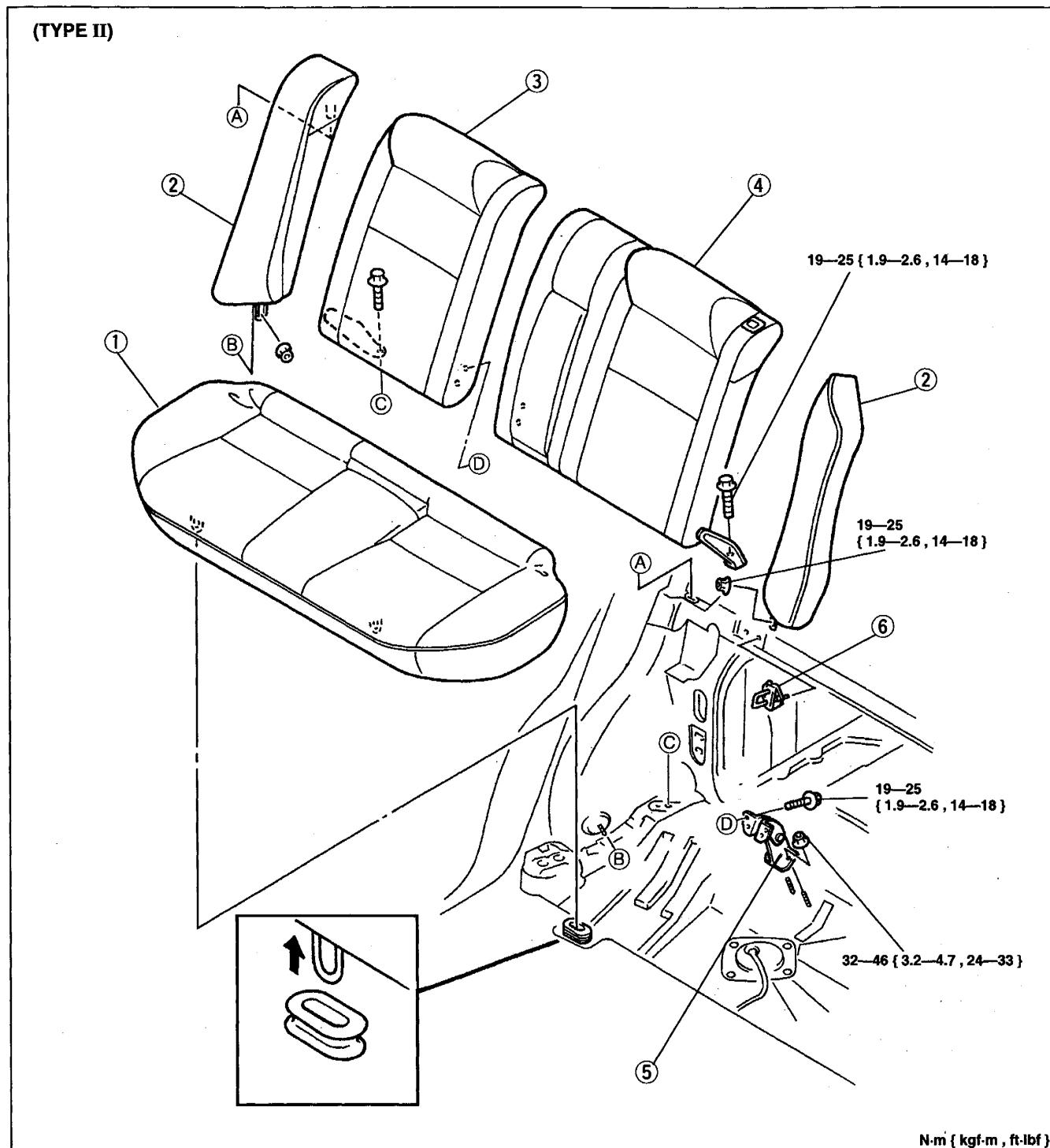

1. Rear seat cushion
Disassembly / Assembly page S1-130
2. Rear seat side bolster
Disassembly / Assembly page S1-130
3. Rear seat back (RH)
Disassembly / Assembly page S1-130

4. Rear seat back (LH)
Disassembly / Assembly page S1-130
5. Rear seat center hinge
6. Rear seat back striker

Disassembly / Assembly

1. Disassemble in the order shown in the figure, referring to **Disassembly note**.
2. Assemble in the reverse order of disassembly.

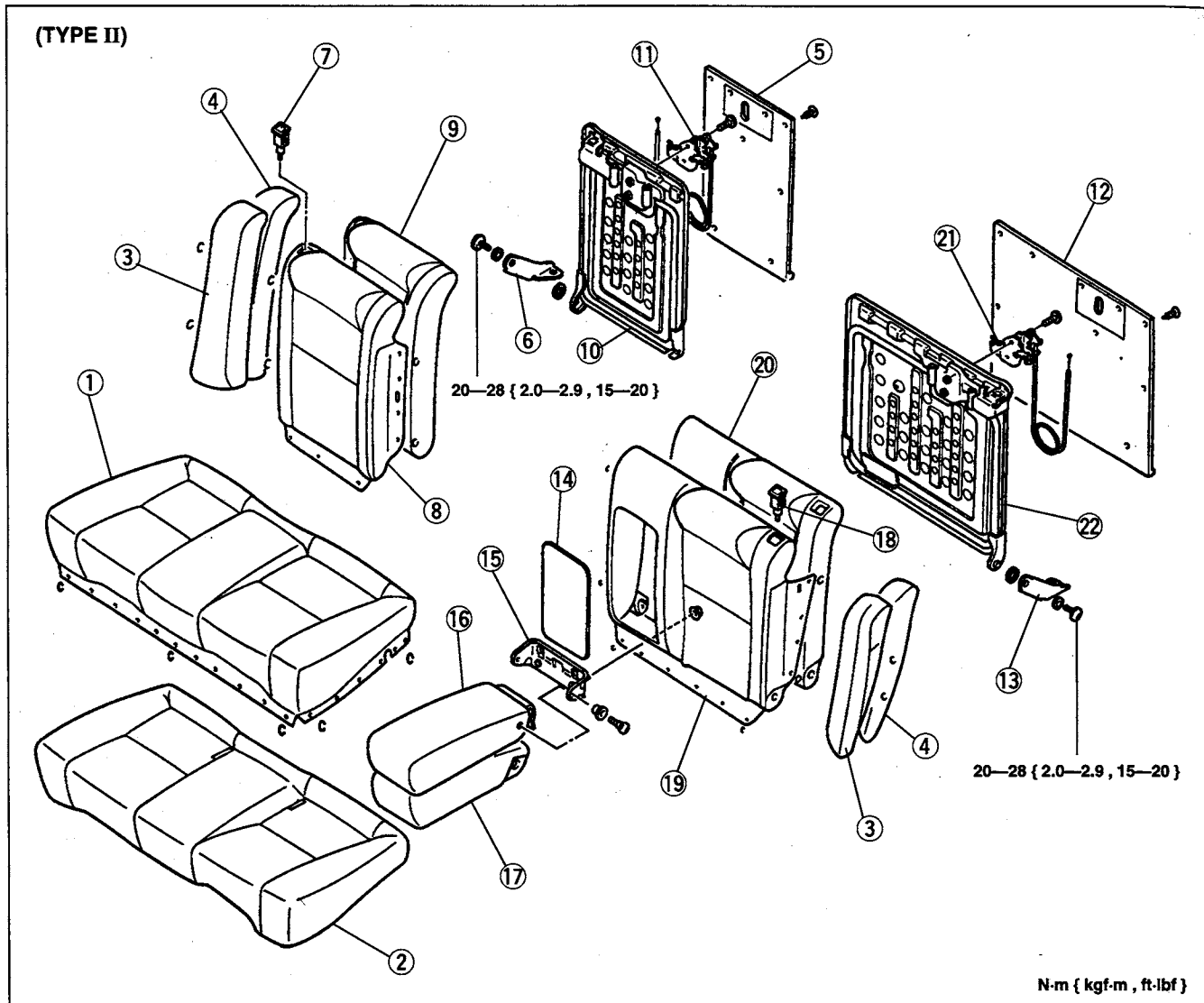

Rear seat cushion

1. Rear seat cushion trim
Disassembly note page S1-131

2. Rear seat cushion pad

Rear seat side bolster

3. Rear seat side bolster trim
Disassembly note page S1-131

4. Rear seat side bolster pad

Rear seat back (RH)

5. Trunk mat
6. Rear seat back side hinge
7. Rear seat back lock knob
Disassembly note page S1-131
8. Rear seat back trim
Disassembly note page S1-131
9. Rear seat back pad
10. Rear seat back frame
11. Rear seat back lock

Rear seat back (LH)

12. Trunk mat
13. Rear seat back side hinge
14. Armrest board
Disassembly note page S1-132
15. Armrest bracket
16. Armrest trim
17. Armrest pad
18. Rear seat back lock knob
Disassembly note page S1-131
19. Rear seat back trim
Disassembly note page S1-132
20. Rear seat back pad
21. Rear seat back lock
22. Rear seat back frame

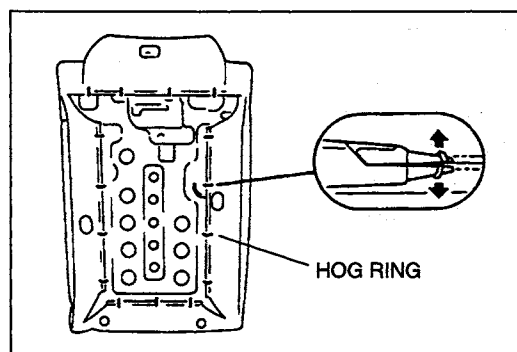
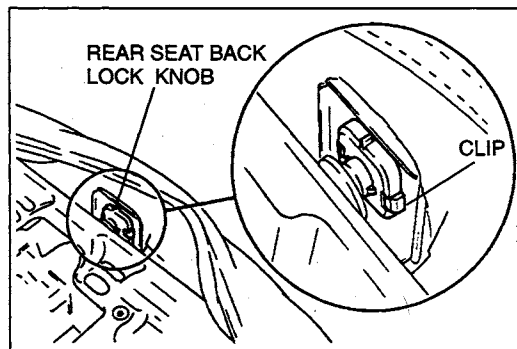
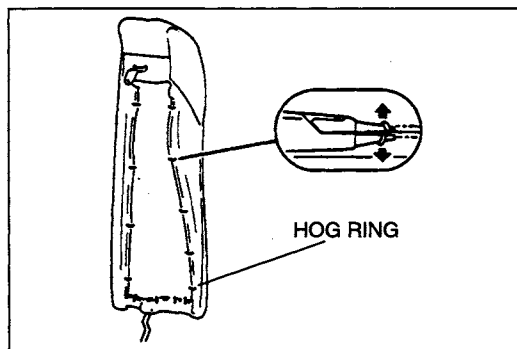
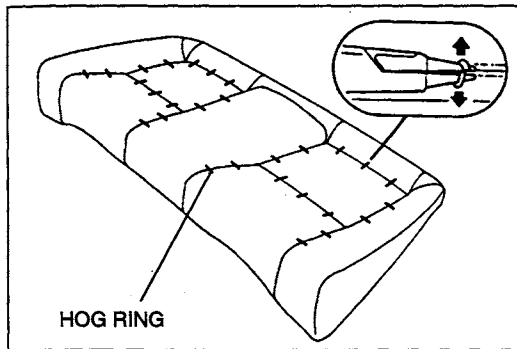
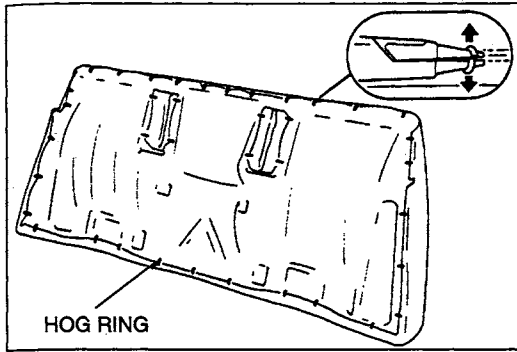

Disassembly note
Rear seat cushion trim

1. Remove the hog rings the rear seat cushion trim.
2. Turn up the rear seat cushion trim and remove the hog rings holding the trim to the pad.

Rear seat side bolster trim

Remove the hog rings from the rear seat side bolster trim.

Rear seat back lock knob

Turn up the rear seat back trim and press the lock knob clips by using pliers.

Rear seat back trim (RH)

1. Remove the hog rings on the back of the rear seat back trim.

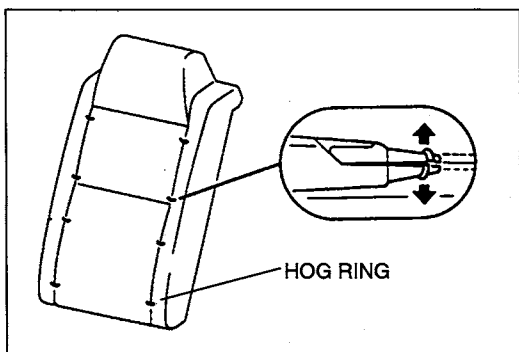

2. Turn up the rear seat back trim and remove the hog rings holding the trim to the pad.

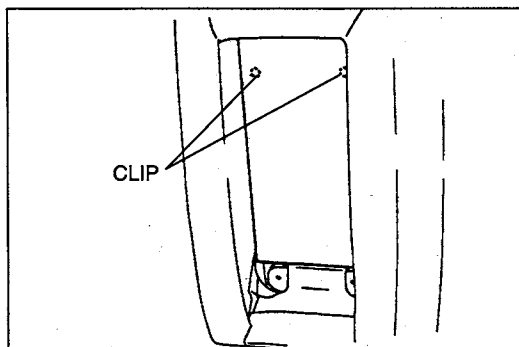

Armrest board

Pull the armrest board forward to disengage the clips from the seat back frame.

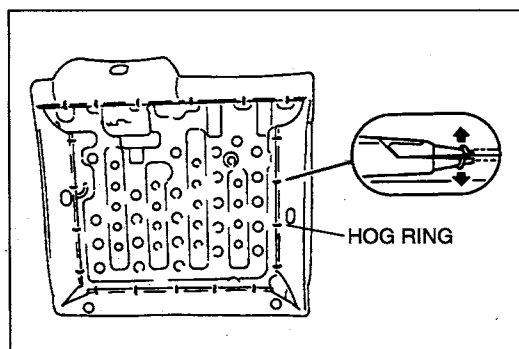

Rear seat back trim (LH)

1. Remove the hog rings on the back of the rear seat back trim.

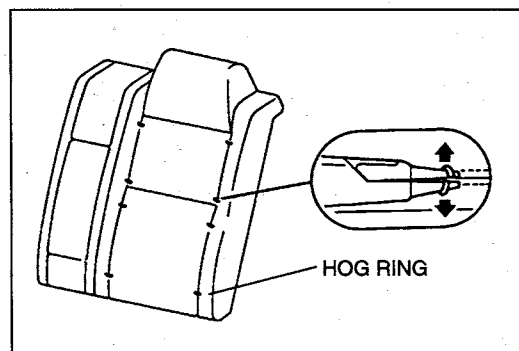

2. Turn up the rear seat back trim and remove the hog rings holding the trim to the pad.

BODY ELECTRICAL SYSTEM

(4 DOOR SEDAN)

POWER SYSTEM	T1- 2	INSTRUMENT CLUSTER	T1- 48
STRUCTURAL VIEW	T1- 2	PREPARATION	T1- 48
MAIN FUSE	T1- 3	STRUCTURAL VIEW	T1- 49
ROOM FUSE	T1- 3	INSTRUMENT CLUSTER	T1- 51
IGNITION SWITCH	T1- 4	SPEEDOMETER	T1- 54
KEY REMINDER SWITCH	T1- 4	TACHOMETER	T1- 54
CPU	T1- 5	WATER TEMPERATURE GAUGE .	T1- 54
STRUCTURAL VIEW	T1- 5	FUEL GAUGE	T1- 55
CPU	T1- 6	WATER TEMPERATURE SENDER	
EXTERIOR LIGHTING SYSTEM	T1-10	UNIT	T1- 55
STRUCTURAL VIEW	T1-10	FUEL GAUGE SENDER UNIT	T1- 56
HEADLIGHT	T1-12	WARNING AND INDICATOR	
PARKING LIGHT	T1-15	LIGHT	T1- 57
FRONT SIDE MARKER LIGHT	T1-15	OIL PRESSURE SWITCH	T1- 58
FRONT TURN LIGHT	T1-16	CLOCK	T1- 58
REAR COMBINATION LIGHT	T1-17	HORN	T1- 59
INBOARD COMBINATION LIGHT ..	T1-18	STRUCTURAL VIEW	T1- 59
LICENCE PLATE LIGHT	T1-19	HORN	T1- 60
HIGH-MOUNT BRAKE LIGHT	T1-19	HORN RELAY	T1- 60
COMBINATION SWITCH	T1-21	AUDIO	T1- 61
HAZARD WARNING SWITCH	T1-28	PREPARATION	T1- 61
FLASHER UNIT	T1-29	STRUCTURAL VIEW	T1- 61
HEADLIGHT RELAY	T1-30	AUDIO UNIT	T1- 62
TNS RELAY	T1-30	SPEAKER	T1- 63
DRL RELAY	T1-30	ROOF ANTENNA	T1- 64
DRL RESISTOR	T1-30	ANTENNA FEEDER	T1- 65
BACK-UP LIGHT SWITCH	T1-31	CRUISE CONTROL SYSTEM	T1- 67
INTERIOR LIGHTING SYSTEM	T1-32	PREPARATION	T1- 67
STRUCTURAL VIEW	T1-32	STRUCTURAL VIEW	T1- 68
INTERIOR AND SPOT LIGHT	T1-33	ON-BOARD DIAGNOSTIC	T1- 69
SPOT LIGHT	T1-34	CRUISE CONTROL MODULE	T1- 89
INTERIOR LIGHT	T1-35	CRUISE ACTUATOR	T1- 91
TRUNK COMPARTMENT LIGHT ...	T1-36	VACUUM PUMP	T1- 92
FRONT ASHTRAY ILLUMINATION .	T1-36	ACTUATOR CABLE	T1- 93
DOOR SWITCH	T1-36	CRUISE CONTROL SWITCH	T1- 94
TRUNK COMPARTMENT LIGHT		CRUISE CONTROL MAIN	
SWITCH	T1-37	SWITCH	T1- 96
PANEL LIGHT CONTROL SWITCH	T1-37	AIR BAG SYSTEM	T1- 97
WINDSHIELD WIPER AND		PREPARATION	T1- 97
WASHER	T1-38	STRUCTURAL VIEW	T1- 97
STRUCTURAL VIEW	T1-38	SERVICE WARNINGS	T1- 98
WINDSHIELD WIPER MOTOR	T1-39	GENERAL PROCEDURES	T1- 99
WINDSHIELD WIPER ARM AND		TROUBLESHOOTING	T1-100
BLADE	T1-42	DRIVER-SIDE AIR BAG MODULE	T1-107
WINDSHIELD WIPER LINK	T1-44	PASSENGER-SIDE AIR BAG	
WINDSHIELD WASHER TANK	T1-45	MODULE	T1-108
WINDSHIELD WASHER MOTOR ..	T1-45	SAS UNIT	T1-109
WINDSHIELD WASHER NOZZLE ..	T1-46	AIR BAG MODULE DISPOSAL	
WINDSHIELD WASHER PIPE	T1-47	PROCEDURE	T1-110
		INSPECTION OF SST	
		(DEPLOYMENT TOOL)	T1-112

POWER SYSTEM

STRUCTURAL VIEW

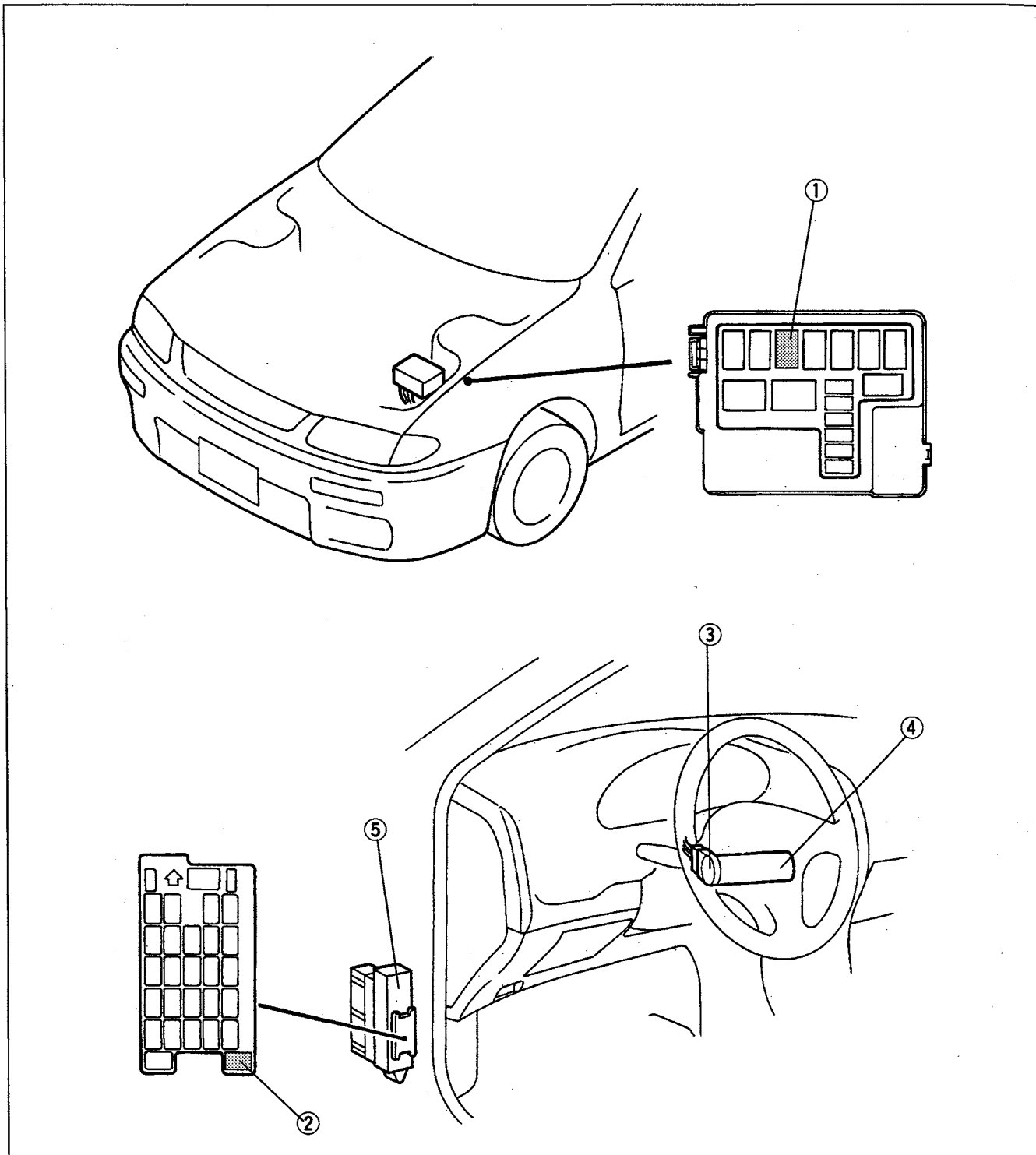

- 1. MAIN fuse
Removal / Installation page T1-3
- 2. ROOM fuse
Installation page T1-3
- 3. Ignition switch
Removal / Installation page T1-4
Inspection page T1-4

- 4. Key reminder switch
Inspection page T1-4
- 5. Joint box
Removal / Installation page T1-6

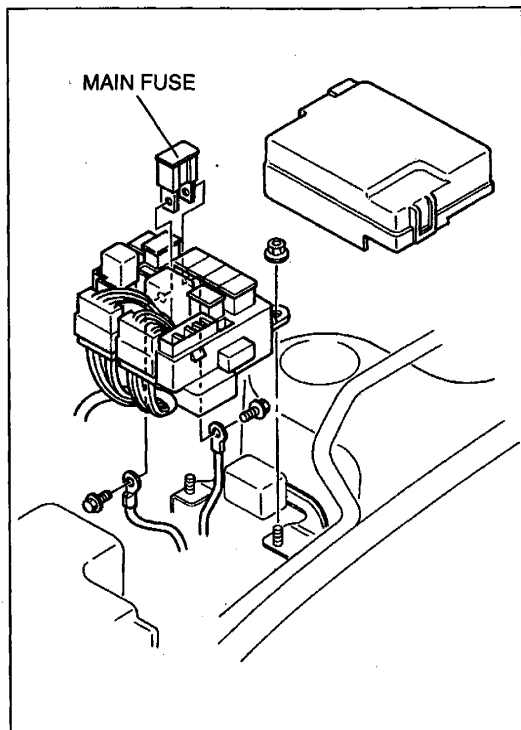
**MAIN FUSE****Removal / Installation**

1. Disconnect the negative battery cable.
2. Remove the main fuse block cover.
3. Remove the main fuse block mounting nuts.
4. Remove the main fuse mounting bolts.
5. Remove the MAIN fuse.
6. Install in the reverse order of removal.

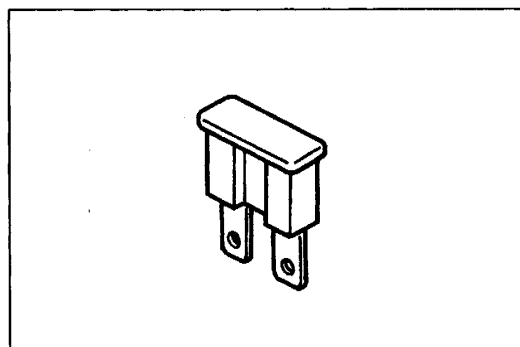
**ROOM FUSE****Installation****Note**

- When the ROOM fuse is burnt or removed, the malfunction indicator lamp illuminates. If the ROOM fuse is replaced or installed with the ignition switch at ON, the malfunction indicator lamp will continue to illuminate.

1. Turn the ignition switch to LOCK.
2. Install the ROOM fuse.

T1

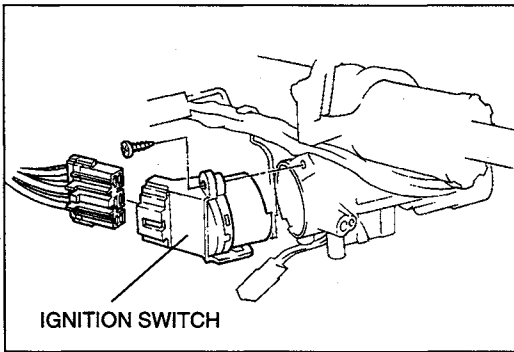

IGNITION SWITCH

Removal / Installation

1. Disconnect the negative battery cable.
2. Remove the column cover.
(Refer to section S1.)
3. Remove the key reminder switch connector from the ignition switch.
4. Disconnect the ignition switch connector and key reminder switch connector.

Note

- If the screw is difficult to remove, remove the steering shaft mounting bolts and lower panel to remove the ignition switch.
(Refer to sections N and S1.)

5. Remove the screw and ignition switch.
6. Install in the reverse order of removal.

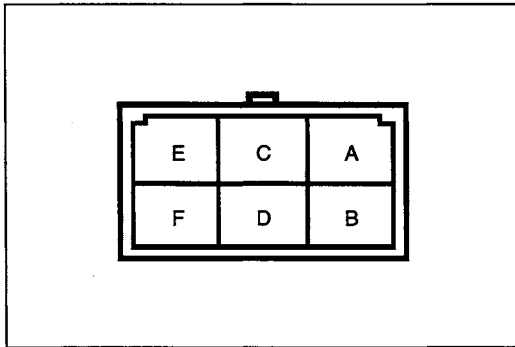

Inspection

1. Remove the ignition switch.
2. Check for continuity between the terminals of the ignition switch.

○—○: Continuity

Switch position \ Terminal	A	B	C	D	E	F
LOCK						
ACC			○—○			○—○
ON	○—○	○—○	○—○	○—○		○—○
START		○—○	○—○	○—○	○—○	

3. If not as specified, replace the ignition switch.

KEY REMINDER SWITCH

Inspection

1. Remove the column cover.
(Refer to section S1.)
2. Disconnect the key reminder switch connector.
3. Check for continuity between the terminals of the key reminder switch.

Switch condition	Continuity
Key inserted	Yes
Key removed	No

4. If not as specified, replace the steering lock.
(Refer to section N.)

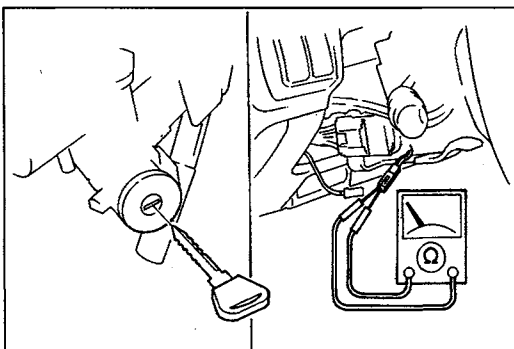

CPU

STRUCTURAL VIEW

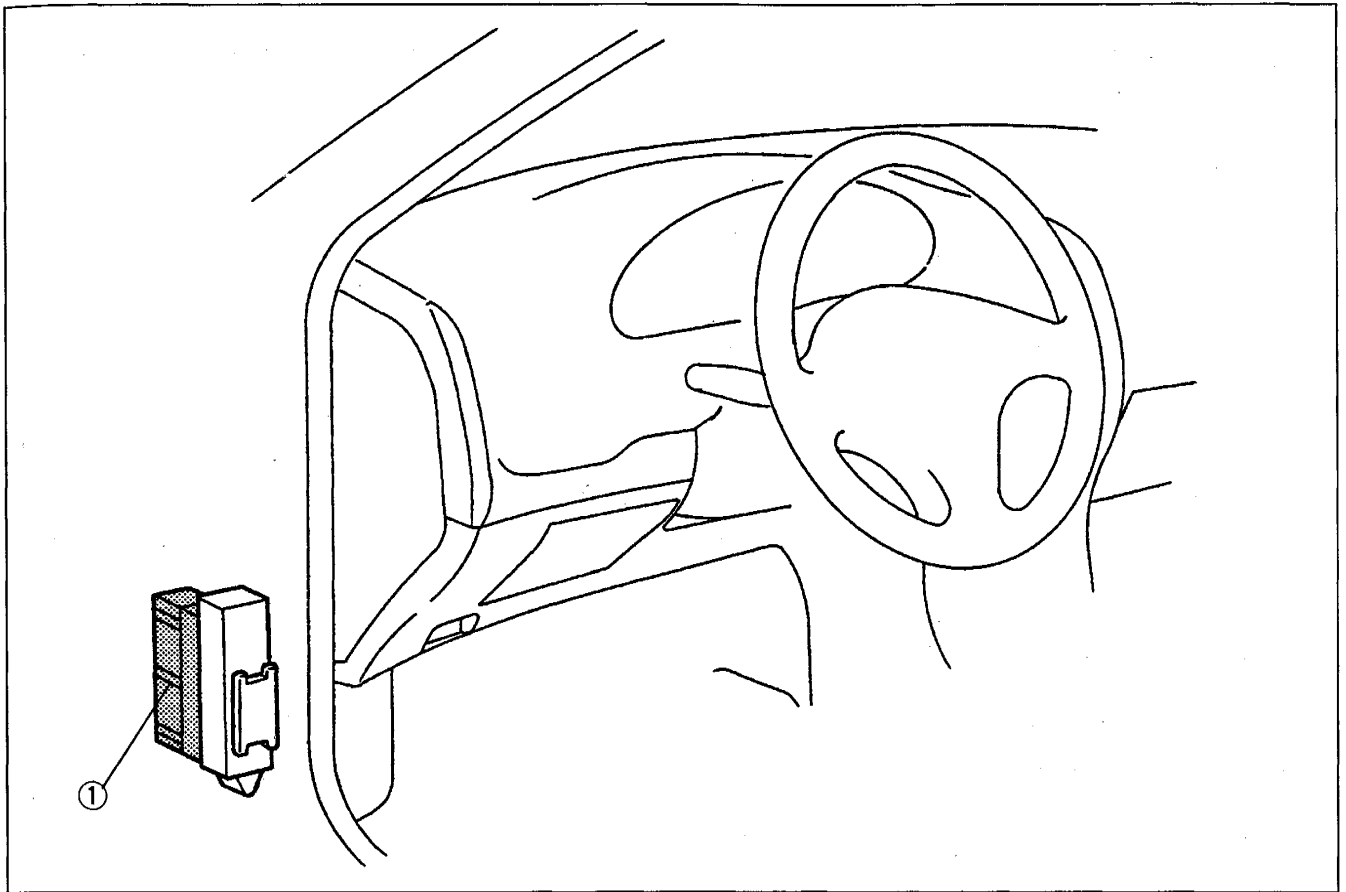

T1

- 1. CPU
 - Removal / Installation page T1-6
 - Inspection page T1-7

CPU

Removal / Installation

1. Disconnect the negative battery cable.
2. Remove the scuff plate and front side trim.
(Refer to section S1.)
3. Disconnect the joint box connectors.
4. Remove in the order shown in the figure.
5. Install in the reverse order of removal.

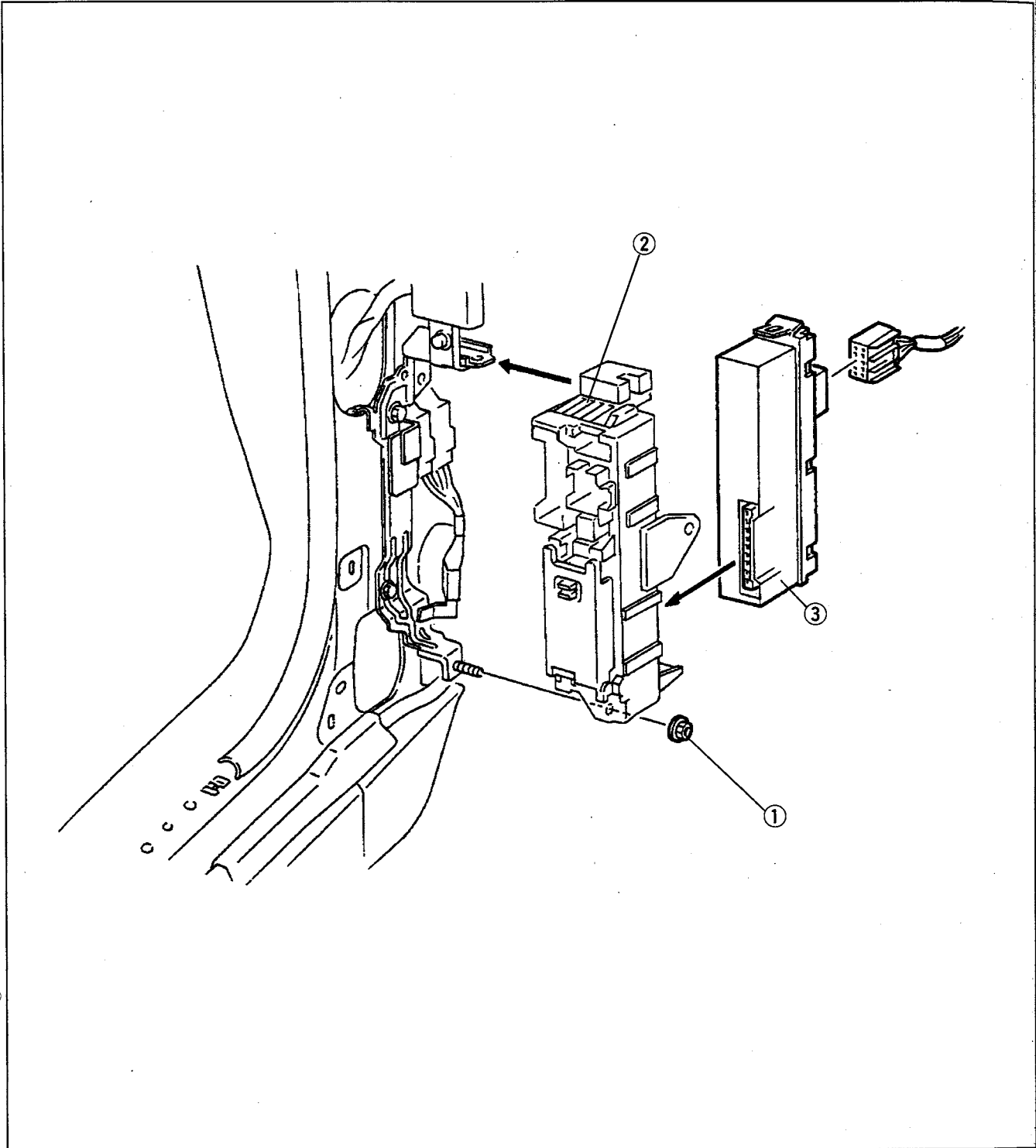

1. Nut
2. Joint box

3. CPU
- Inspection page T1-7

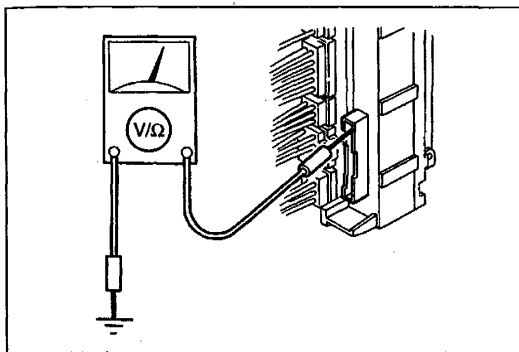

Inspection Connector A

1. Remove the CPU from the joint box.
2. Measure the voltage at the CPU terminals from the joint box side, referring to the terminal voltage list on page T1-8.
3. If not as specified, inspect the parts listed under "Inspection area" and the related wiring harnesses.
4. If the parts and wiring harnesses are OK but the system still does not work properly, replace the CPU.
(Refer to page T1-6.)

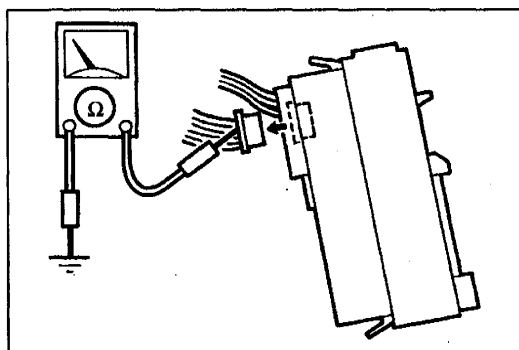

Connector B

1. Follow the appropriate procedure, referring to the terminal voltage list on page T1-9.

Terminal 2I

- (1) Disconnect the CPU connector.
- (2) Check for continuity between the terminal of the CPU connector and ground.

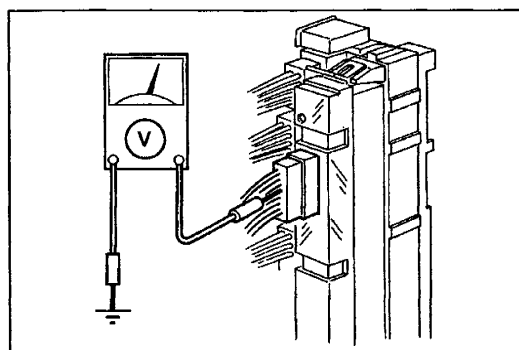

Terminals except 2I

- (1) Install the CPU onto the joint box.
 - (2) Measure the voltage at the CPU terminals.
2. If not as specified, inspect the parts listed under "Inspection area" and the related wiring harnesses.
 3. If the parts and wiring harnesses are OK but the system still does not work properly, replace the CPU.
(Refer to page T1-6.)

Terminal voltage list (Reference)

B+: Battery positive voltage

CONNECTOR A

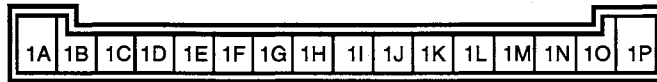

Terminal	Signal	Connection	Test condition		Voltage/Continuity	Inspection area
1A	—	—	—		—	—
1B	—	—	—		—	—
1C	ACC	RADIO 15 A fuse	Ignition switch at ACC		B+	RADIO 15 A fuse
1D	—	—	—		—	—
1E	—	—	—		—	—
1F	Interior light	Interior light	Interior light switch at DOOR		B+	<ul style="list-style-type: none"> ROOM 15 A fuse Interior light
1G	CPU ground	GND	Constant: check for continuity to ground		Yes	—
1H	Door open/closed	Door switch (except driver)	Any door open: check for continuity to ground		Yes	Door switch
			All doors closed: check for continuity to ground		No	
1I	—	—	—		—	—
1J	+B	ROOM 15 A fuse	Constant		B+	ROOM 15 A fuse
1K	Key inserted	Key reminder switch	Ignition key inserted		B+	<ul style="list-style-type: none"> ROOM 15 A fuse Key reminder switch
1L	TNS	TNS relay	Parking light illuminated		B+	<ul style="list-style-type: none"> TAIL 15 A fuse TNS relay
1M	IG1	METER 15 A fuse	Ignition switch at ON		B+	METER 15 A fuse
1N	Seat belt warning	<ul style="list-style-type: none"> Seat belt warning light Buckle switch 	Ignition switch at ON	Seat belt fastened	B+	<ul style="list-style-type: none"> METER 15 A fuse Instrument cluster Buckle switch
				Seat belt unfastened	0 V	
1O	Door open/closed	Door switch (driver)	Door open: check for continuity to ground		Yes	Door switch
			Door closed: check for continuity to ground		No	
1P	—	—	—		—	—

B+: Battery positive voltage

CONNECTOR B

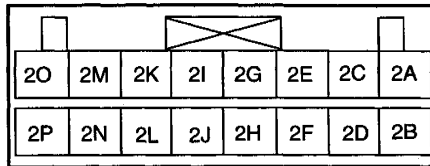

Terminal	Signal	Connection	Test condition		Voltage/ Continuity	Inspection area
2A	Power door lock control	Door lock timer unit	For 0.27 seconds after driver's door key cylinder switch is unlocked		0 V	<ul style="list-style-type: none"> D.LOCK 30 A fuse Door lock timer unit
			Other		B+	
2B	—	—	—		—	—
2C	Power door lock control	Door lock timer unit	For 0.27 seconds after driver's door key cylinder switch is locked		0 V	<ul style="list-style-type: none"> D.LOCK 30 A fuse Door lock timer unit
			Other		B+	
2D	DRL	DRL relay	Ignition switch at ON		B+	<ul style="list-style-type: none"> A/C 10 A fuse DRL relay
2E	DRL	Combination switch	Headlight illuminated		B+	Combination switch
2F	Brake light	Brake switch	Brake light illuminated		B+	Brake switch
2G	Shift-lock control (lock)	Shift-lock actuator	Ignition switch at ON and selector lever at P range	Brake pedal depressed	0 V	<ul style="list-style-type: none"> Shift-lock actuator P range switch
				Brake pedal released	B+	
2H	Shift-lock control (unlock)	Shift-lock actuator	Ignition switch at ON and selector lever at P range	For 1 second after brake pedal is depressed	0 V	<ul style="list-style-type: none"> Shift-lock actuator P range switch
				Other	B+	
2I	Parking brake	Parking brake switch	Parking brake pulled: check for continuity to ground		Yes	Parking brake switch
			Parking brake released: check for continuity to ground		No	
2J	Key cylinder	Door key cylinder switch (passenger)	At lock position		2.5 V	Door key cylinder switch
			At unlock position		0 V	
			Other		5 V	
2K	Brake system warning	<ul style="list-style-type: none"> Brake system warning light Brake fluid level sensor 	Ignition switch at ON	Brake system warning light illuminated	0 V	<ul style="list-style-type: none"> METER 15 A fuse Instrument cluster Brake fluid level sensor
				Other	B+	
2L	Key cylinder	Door key cylinder switch (driver)	At lock position		2.5 V	Door key cylinder switch
			At unlock position		0 V	
			Other		5 V	
2M	—	—	—		—	—
2N	DRL	Combination switch	Headlight switch on	Dimmer switch at high position	B+	Combination switch
				Other	0 V	
2O	—	—	—		—	—
2P	—	—	—		—	—

T1

EXTERIOR LIGHTING SYSTEM

STRUCTURAL VIEW

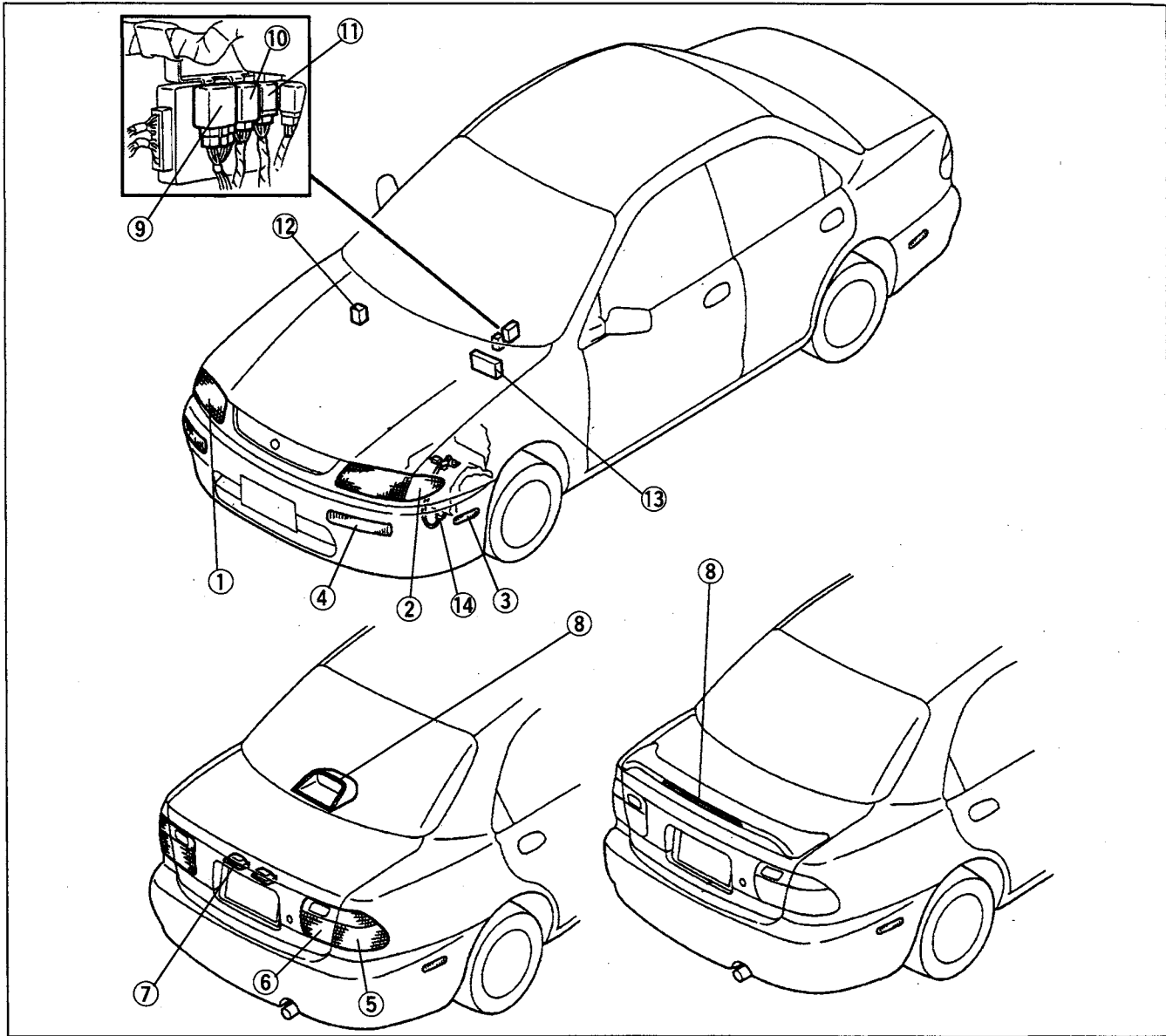

- | | |
|------------------------------|------------|
| 1. Headlight | |
| Removal / Installation | page T1-12 |
| Aiming | page T1-13 |
| Bulb replacement | page T1-14 |
| 2. Parking light | |
| Removal / Installation | page T1-15 |
| 3. Front side marker light | |
| Removal / Installation | page T1-15 |
| 4. Front turn light | |
| Removal / Installation | page T1-16 |
| 5. Rear combination light | |
| Removal / Installation | page T1-17 |
| 6. Inboard combination light | |
| Removal / Installation | page T1-18 |
| Bulb replacement | page T1-18 |
| 7. Licence plate light | |
| Removal / Installation | page T1-19 |
| 8. High-mount brake light | |
| Removal / Installation | page T1-19 |
| Bulb replacement | page T1-20 |
| 9. Flasher unit | |
| Removal / Installation | page T1-29 |
| Inspection | page T1-29 |
| 10. Headlight relay | |
| Inspection | page T1-30 |
| 11. TNS relay | |
| Inspection | page T1-30 |
| 12. DRL relay | |
| Inspection | page T1-30 |
| 13. DRL resistor | |
| Inspection | page T1-30 |
| 14. Back-up light switch | |
| Removal / Installation | page T1-31 |
| Inspection | page T1-31 |

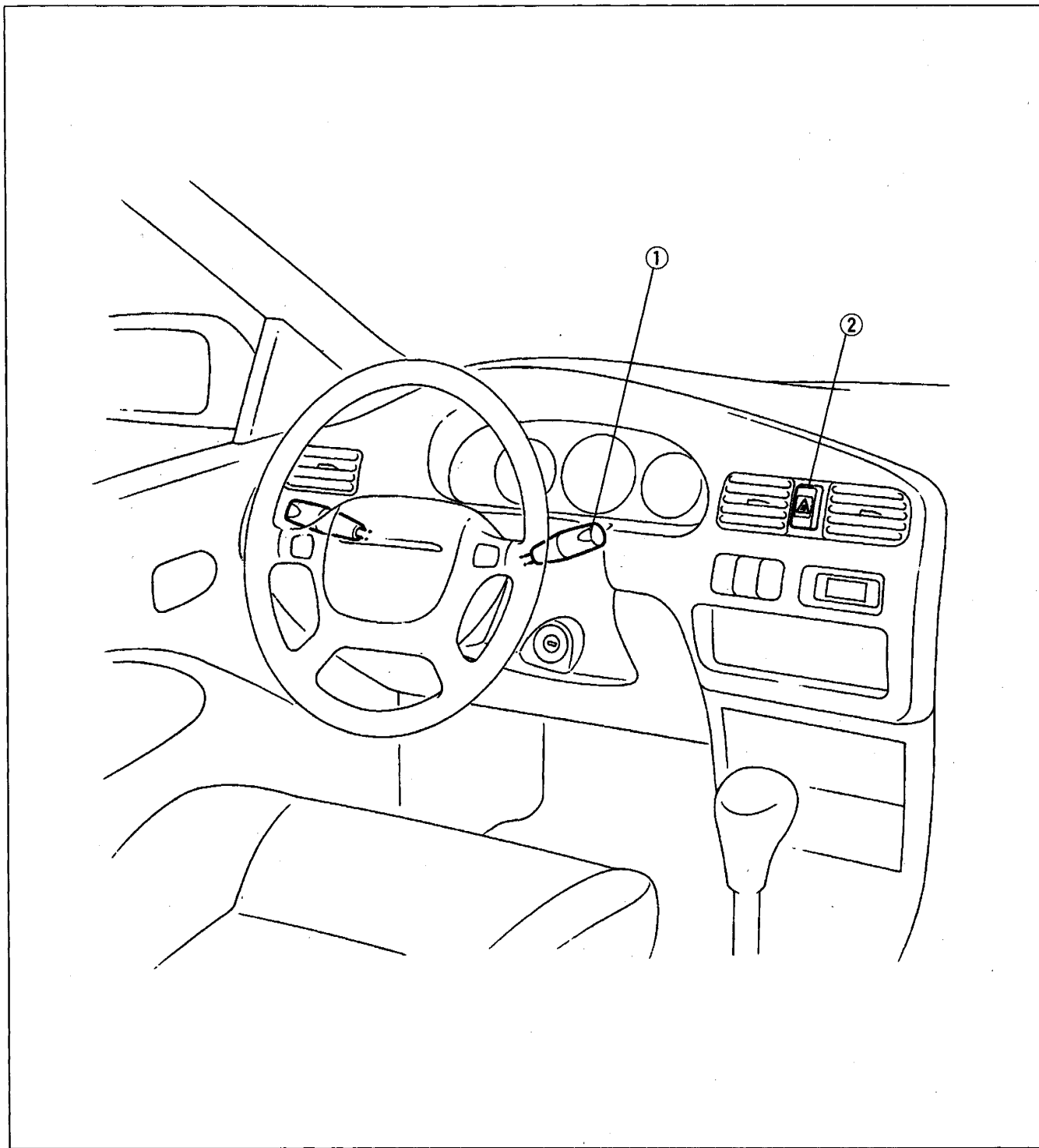

- 1. Combination switch
 - Removal / Installation page T1-21
 - Disassembly / Assembly page T1-23
 - Inspection page T1-24
 - Adjustment page T1-27

- 2. Hazard warning switch
 - Removal / Installation page T1-28
 - Inspection page T1-28

HEADLIGHT

Removal / Installation

1. Remove the radiator grille and upper seal board.
(Refer to section S1.)
2. Remove the parking light.
(Refer to page T1-15.)
3. Remove in the order shown in the figure.
4. Install in the reverse order of removal.

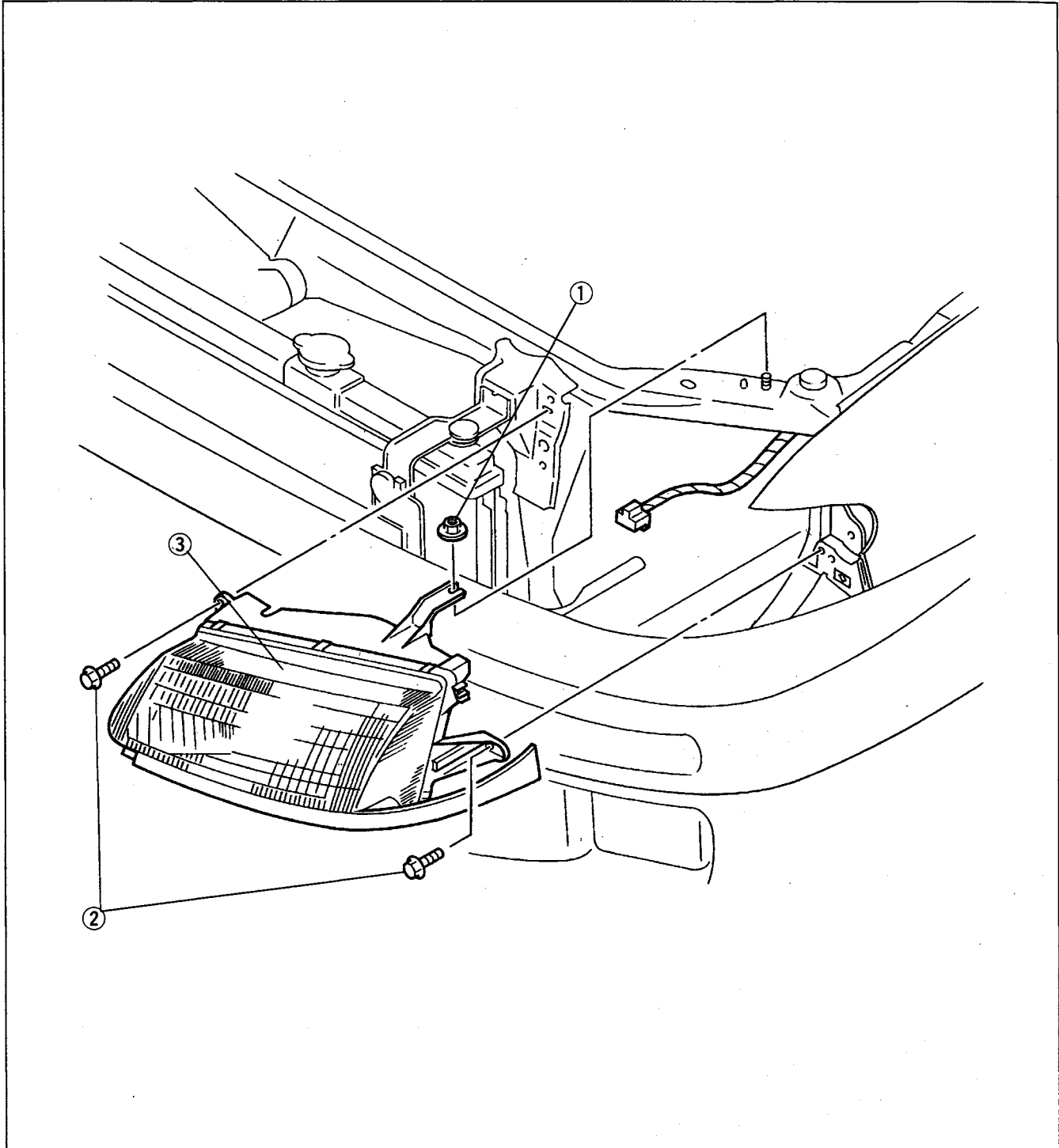

1. Nut
2. Bolts

3. Headlight
Aiming page T1-13
Bulb replacement page T1-14

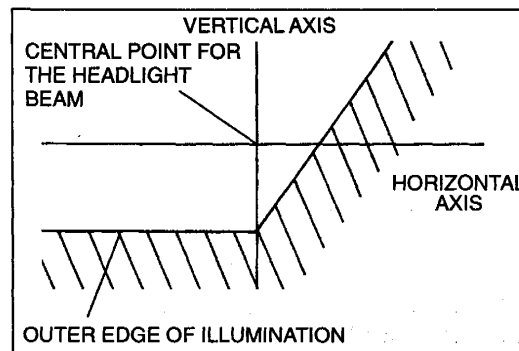
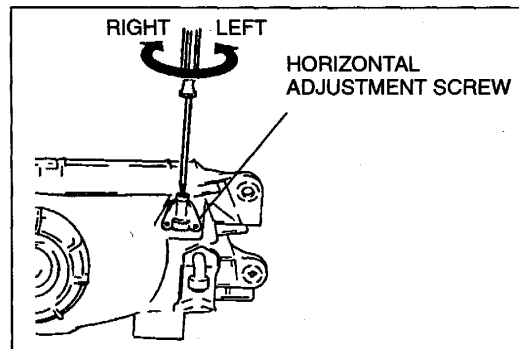
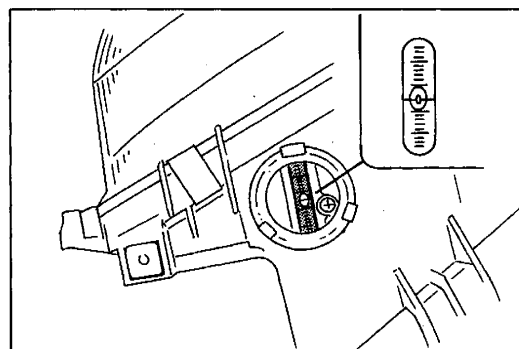
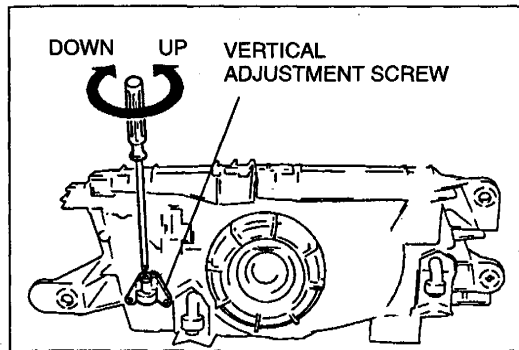
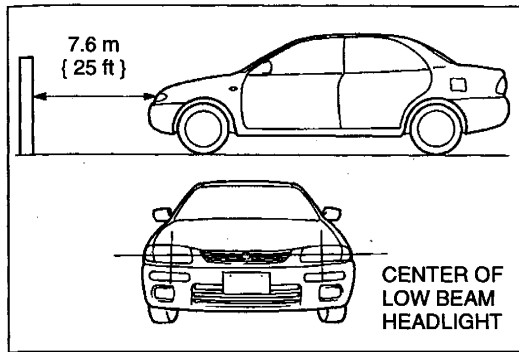

Aiming

Vertical-horizontal aiming method

1. Adjust the tire air pressure to specification. (Refer to section Q.)
2. Fill the fuel tank and remove excess cargo.
3. Position the unloaded vehicle on a flat level surface.
4. Position the vehicle straight ahead to the headlight tester. Set the distance between the headlight and the tester to 7.6 m { 25 ft }.
5. Disconnect the connector of the other headlight.
6. Adjust the up/down position of the headlight by using the vertical aiming gauge. Make sure the bubble in the gauge is within the two lines on either side of the center "0".
7. Turn the headlights on at low beam.
8. Adjust the headlights by turning the horizontal adjustment screw until the field of illumination is as shown.

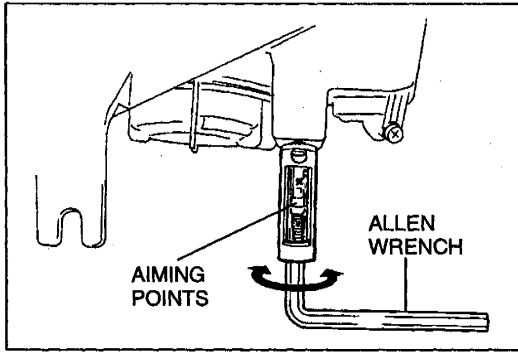

9. Align the aiming points by using an Allen wrench.
10. Do this procedure for both RH and LH headlights.

Note

- Simple aiming adjustments can be done correctly by following the above procedures, by turning the horizontal adjustment screw, and by aligning the aiming points.

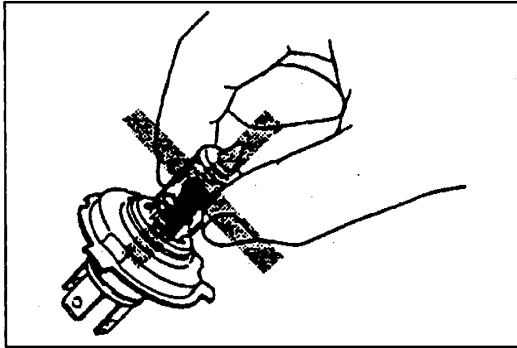

Warning

- If the glass surface of a halogen bulb is touched with bare hands, natural body oil could cause the bulb to overheat when it is lit. Because a halogen bulb contains pressurized gas, this overheating will cause the bulb to burst. The flying glass may seriously injure you. Hold the metal flange, not the glass, when replacing the bulb.

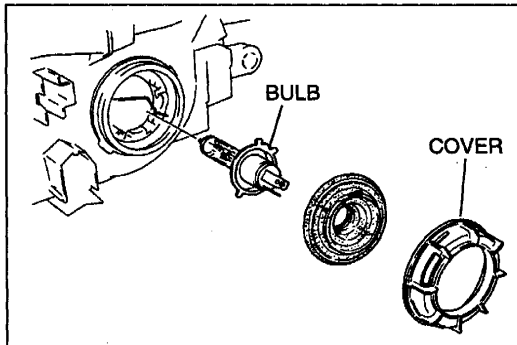

Bulb Replacement

1. Disconnect the headlight connector.
2. Remove the cover.
3. Remove the headlight bulb.
4. Install in the reverse order of removal.

Headlight bulb: High/Low 60/55 W

PARKING LIGHT
Removal / Installation

1. Remove in the order shown in the figure.
2. Install in the reverse order of removal.

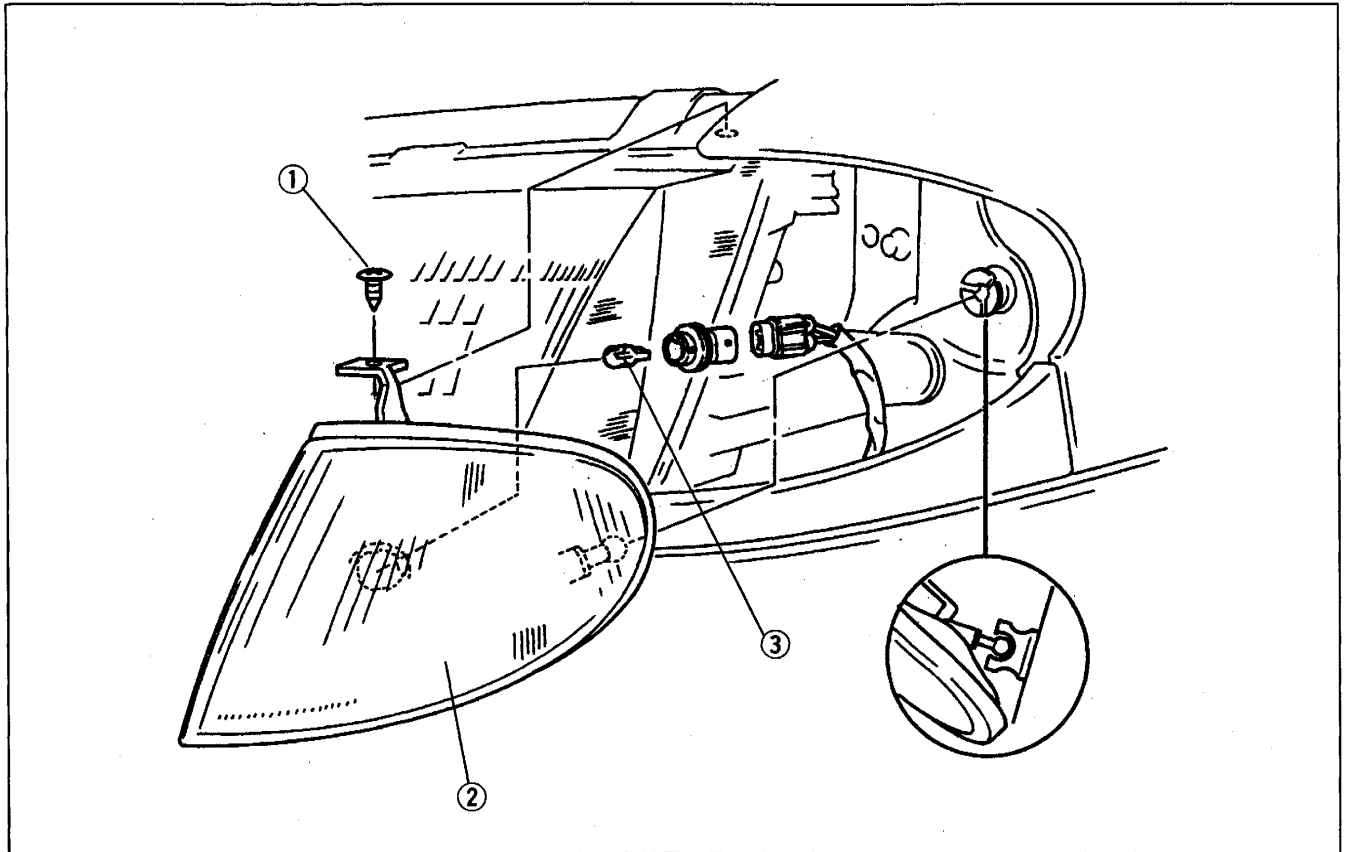

1. Screw
2. Parking light

3. Bulb (5 W)

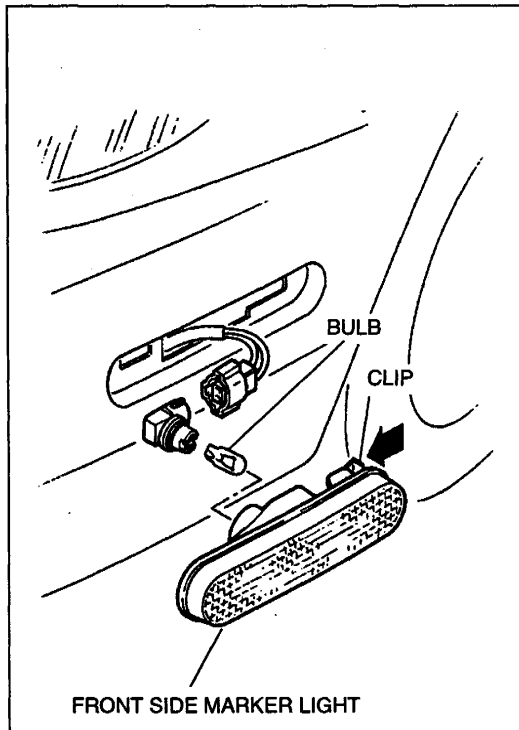

FRONT SIDE MARKER LIGHT
Removal / Installation

1. Turn over the front mud guard.
2. Remove the front side marker light by pressing on the side with the cut-away tab then pulling out the light.
3. Remove the socket and bulb.
4. Install in the reverse order of removal.

Front side marker light bulb: 3.8 W

FRONT TURN LIGHT

Removal / Installation

1. Remove in the order shown in the figure.
2. Install in the reverse order of removal.

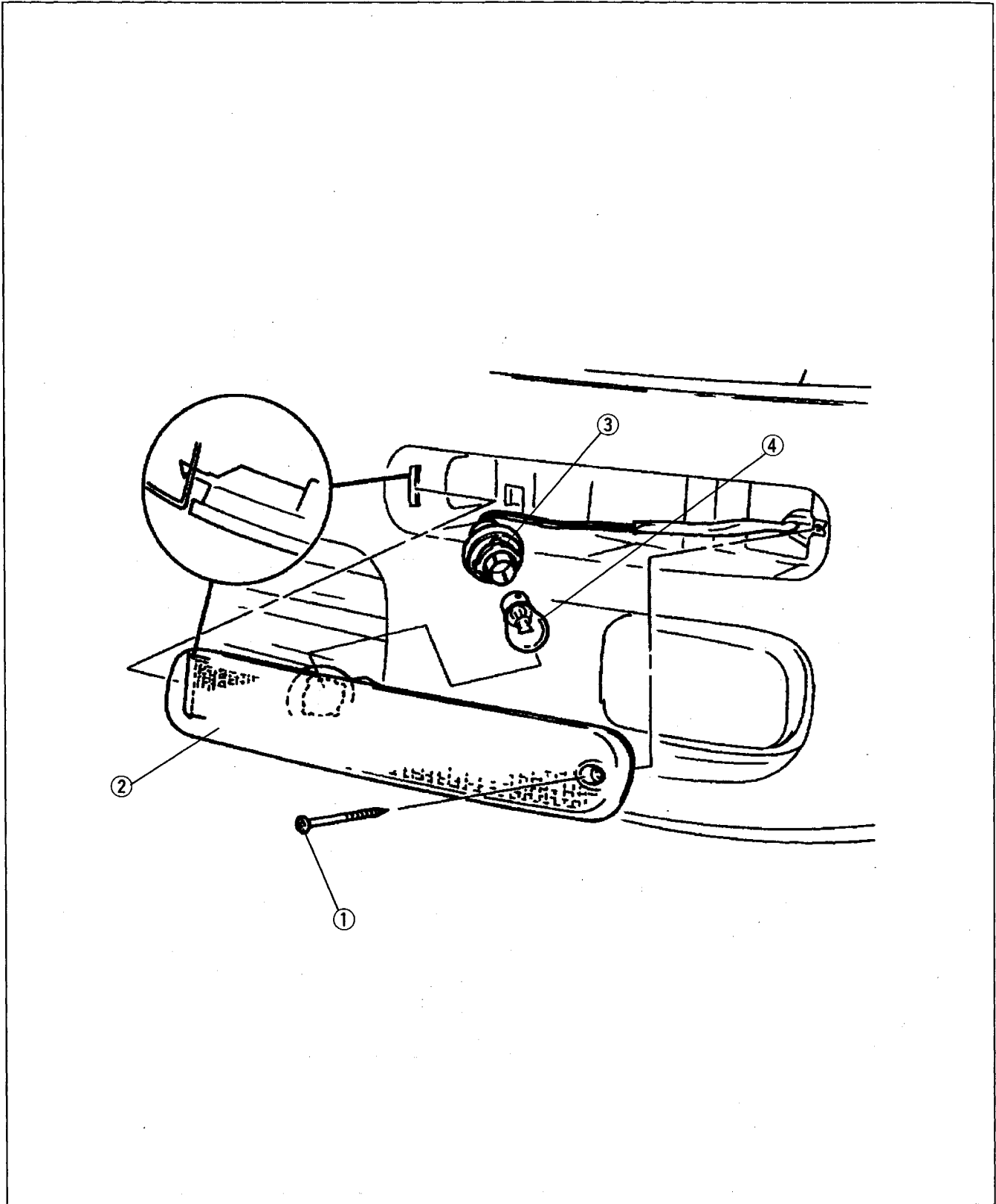

1. Screw
2. Front turn light

3. Socket
4. Bulb (27 W)

REAR COMBINATION LIGHT

Removal / Installation

1. Remove in the order shown in the figure.
2. Install in the reverse order of removal.

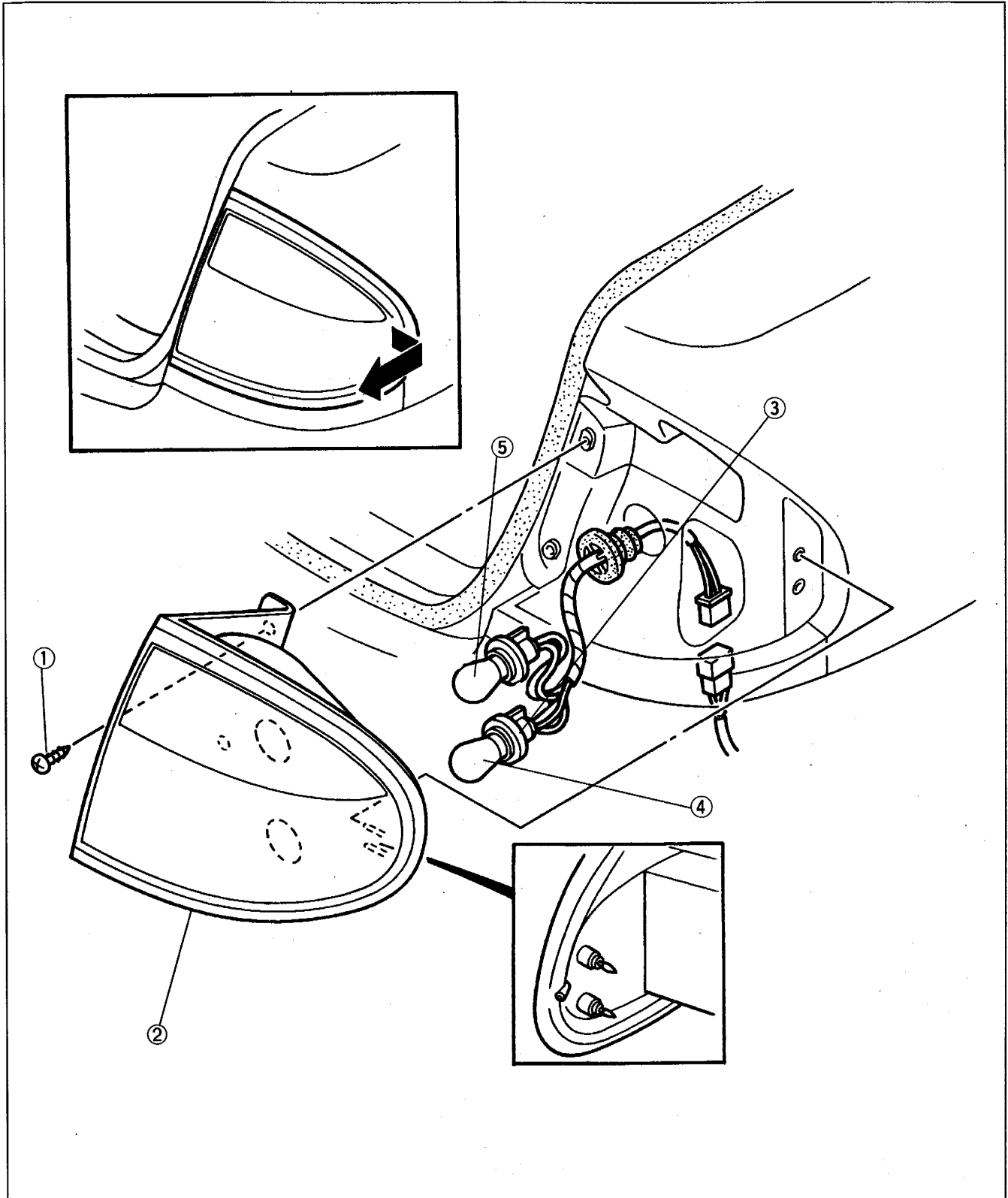

1. Screw
2. Rear combination light
3. Socket

4. Bulb (brake light/taillight: 27/8 W)
5. Bulb (rear turn light: 27 W)

INBOARD COMBINATION LIGHT

Removal / Installation

1. Remove the trunk lid trim.
(Refer to section S1.)
2. Remove in the order shown in the figure.
3. Install in the reverse order of removal.

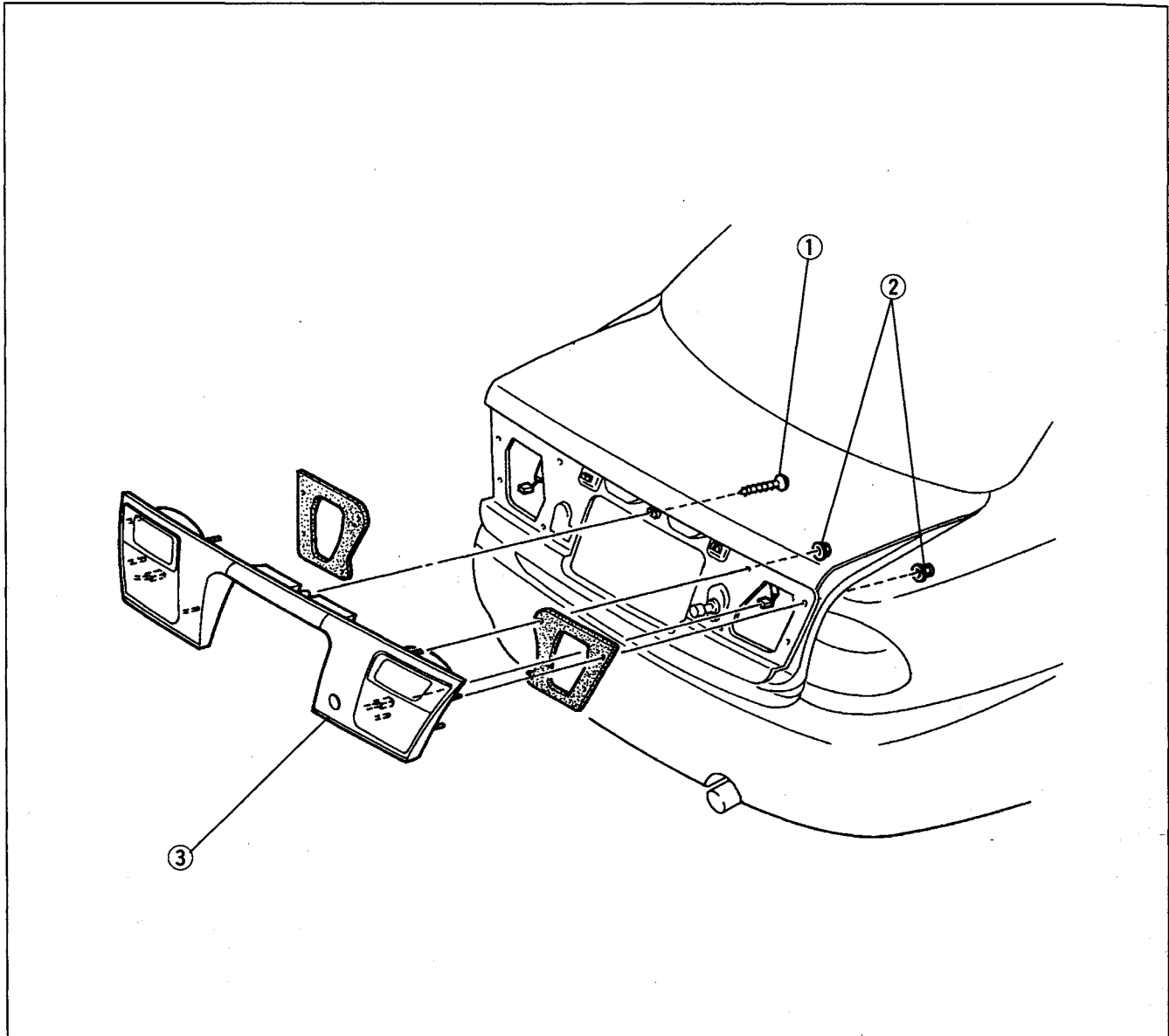

1. Screw
2. Nuts

3. Inboard combination light

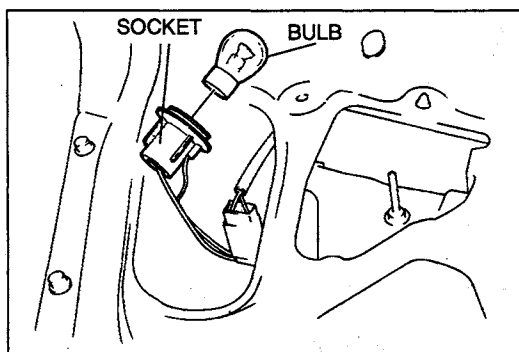

Bulb replacement

1. Remove the trunk lid trim.
(Refer to section S1.)
2. Remove the socket.
3. Remove the bulb.
4. Install in the reverse order of removal.

Back-up light bulb: 21 W

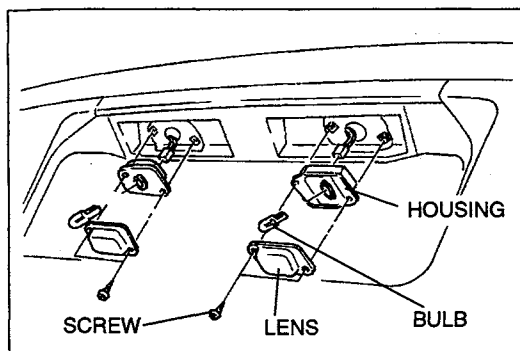

**LICENCE PLATE LIGHT
Removal / Installation**

1. Remove the screws.
2. Remove the lens.
3. Disconnect the licence plate light connector.
4. Remove the housing.
5. Remove the bulb.
6. Install in the reverse order of removal.

Licence plate light bulb: 5 W

HIGH-MOUNT BRAKE LIGHT

Removal / Installation

With rear spoiler

1. Remove the rear spoiler.
(Refer to section S1.)
2. Remove in the order shown in the figure.
3. Install in the reverse order of removal.

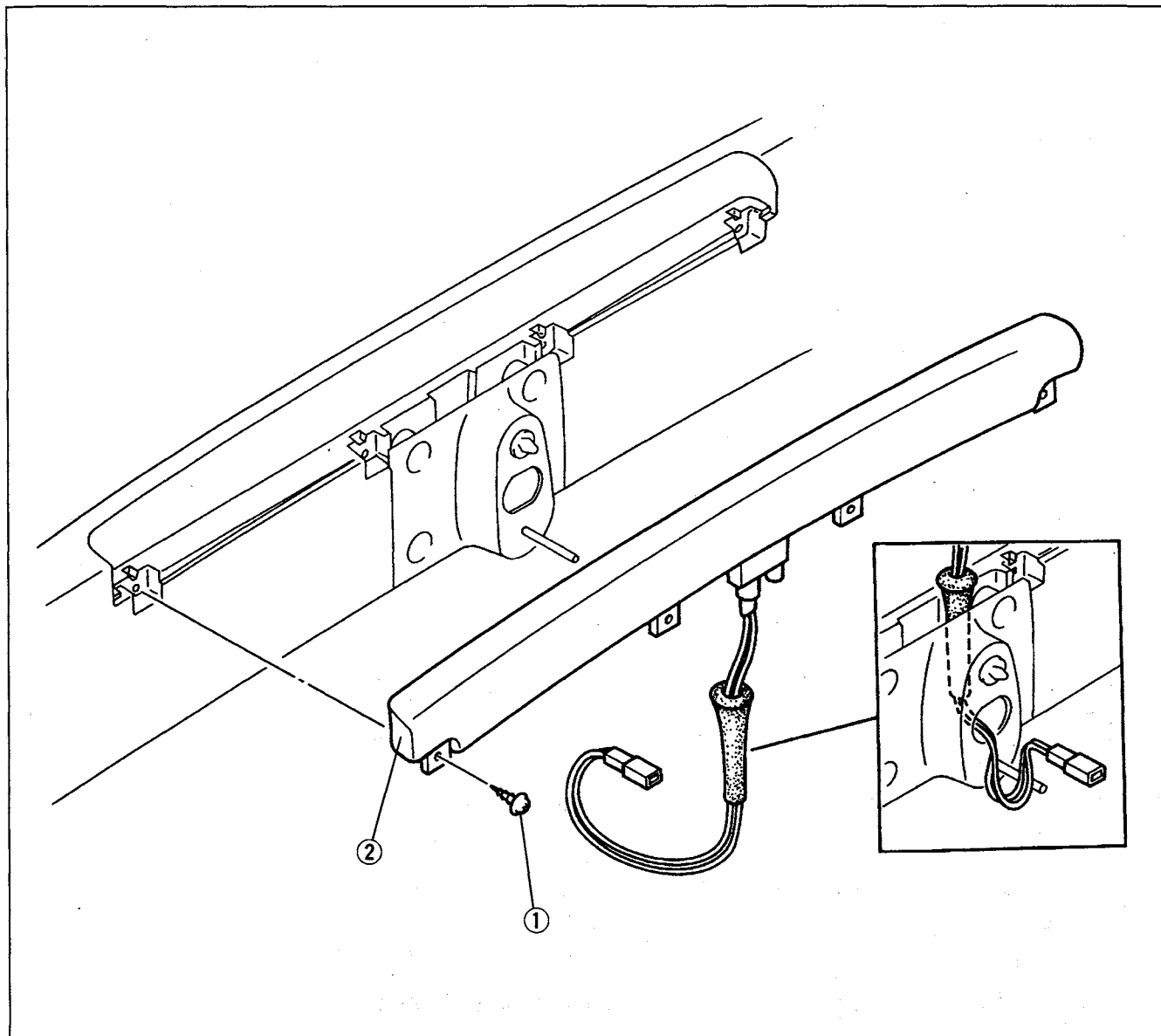

1. Screw

2. High-mount brake light

Without rear spoiler

1. Remove in the order shown in the figure.
2. Install in the reverse order of removal.

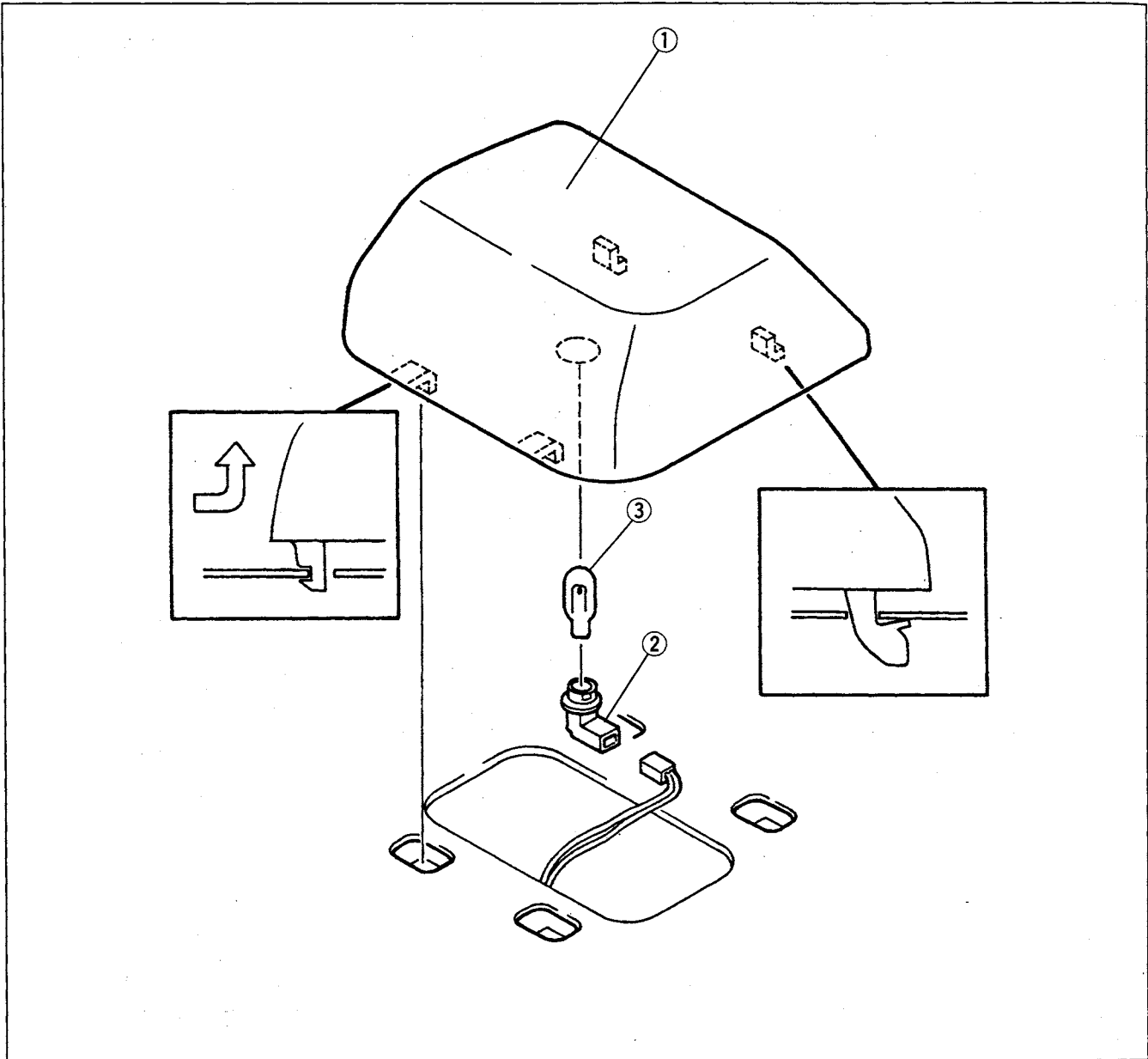

1. High-mount brake light
2. Socket

3. Bulb (18 W)

COMBINATION SWITCH
Removal / Installation
With air bag system

Warning

- Handling the air bag module improperly can accidentally deploy the air bag, which may seriously injure you. Read **SERVICE WARNINGS**, page T1-98, before handling the air bag module.

1. Remove in the order shown in the figure.
2. Install in the reverse order of removal.

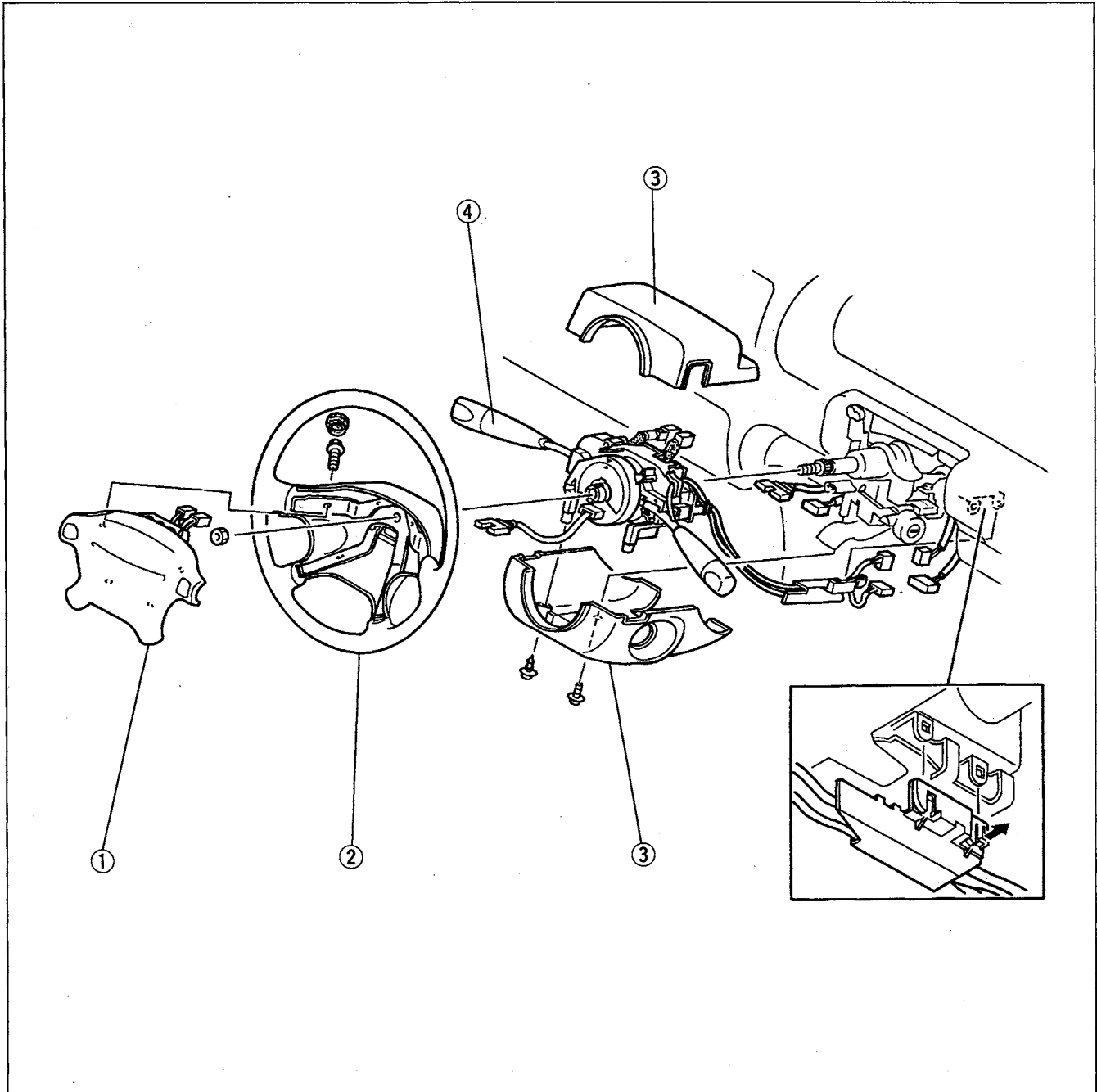

1. Air bag module
Removal / Installation page T1-107
2. Steering wheel
Removal / Installation section N

3. Column cover
Removal / Installation section S1
4. Combination switch
Inspection page T1-24
Adjustment page T1-27

Without air bag system

1. Remove in the order shown in the figure.
2. Install in the reverse order of removal.

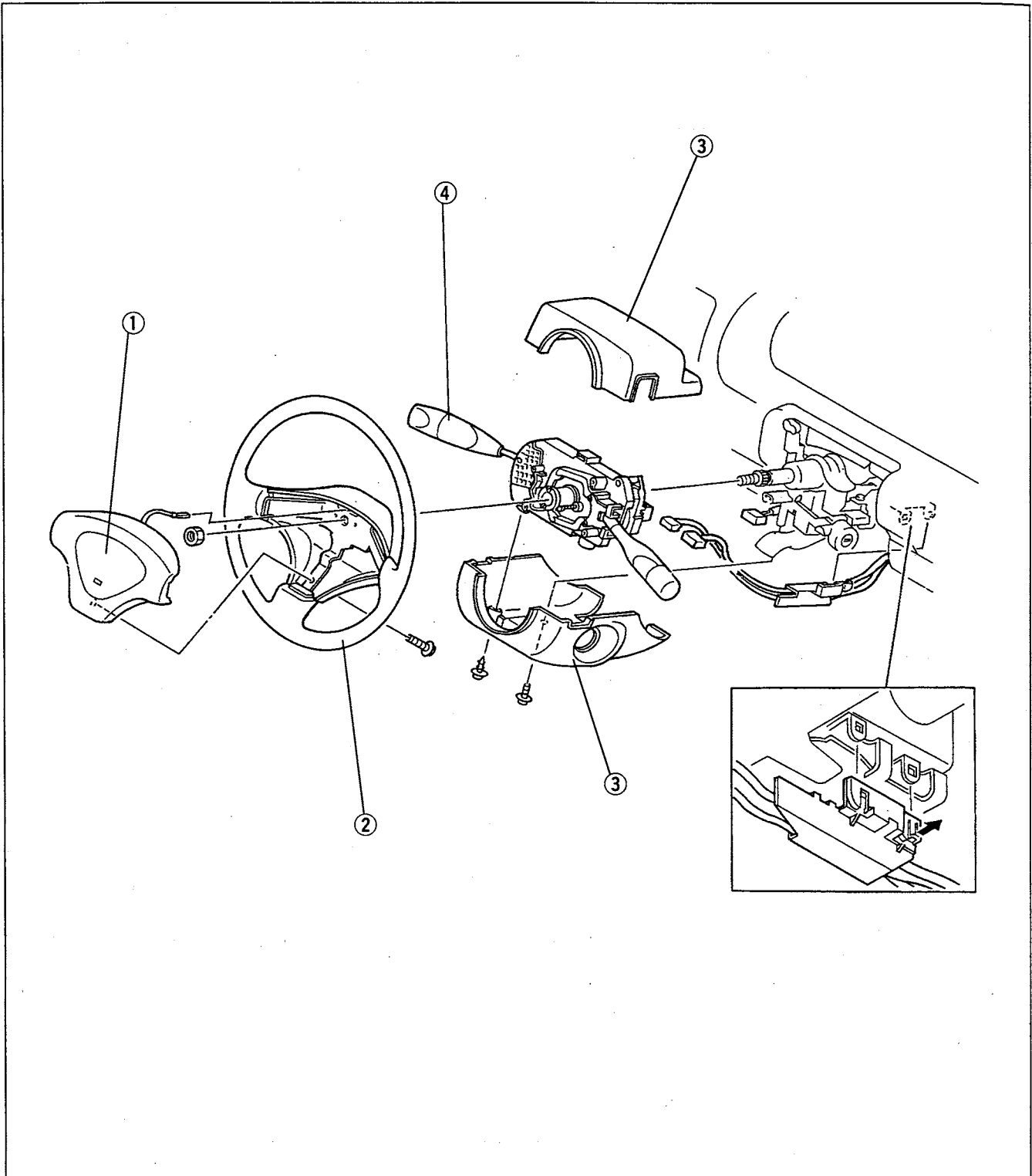

1. Horn cap
Removal / Installation section N
2. Steering wheel
Removal / Installation section N
3. Column cover
Removal / Installation section S1

4. Combination switch
Disassembly / Assembly page T1-23
Inspection page T1-26

**Disassembly / Assembly
Without air bag system**

1. Disassemble in the order shown in the figure.
2. Assemble in the reverse order of disassembly.

Caution

- The combination switch on vehicles with an air bag has a clock spring that will unwind if the switch is disassembled. The spring cannot be rewound by hand. If this occurs, the combination switch will not work properly. Therefore, do not disassemble the combination switch if an air bag is installed.

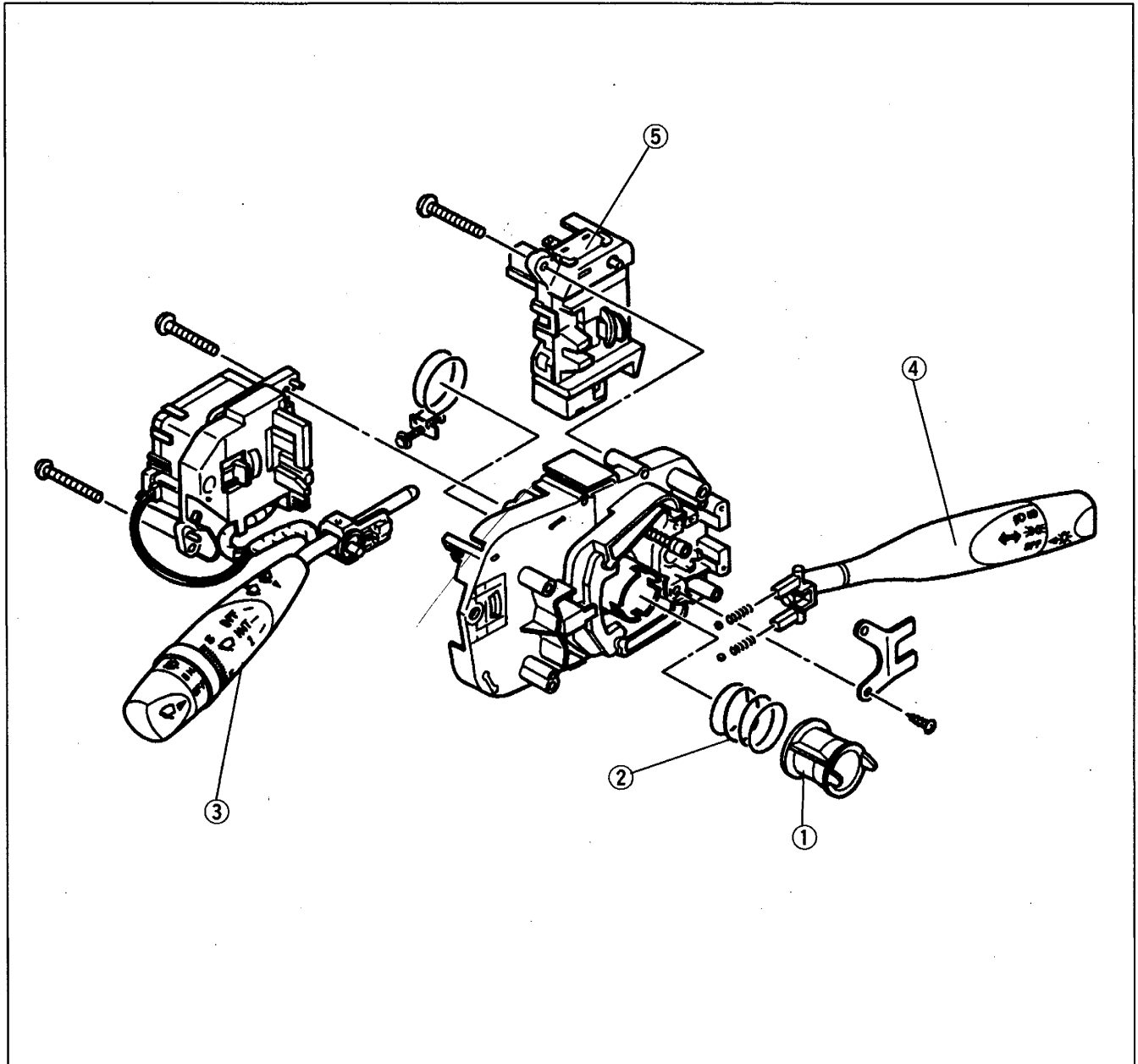

1. Cancel cam
2. Spring
3. Wiper lever

4. Light lever
5. Light unit

Inspection

With air bag system

1. Check for continuity between the switch terminals as indicated below.
2. If not as specified, replace the combination switch.

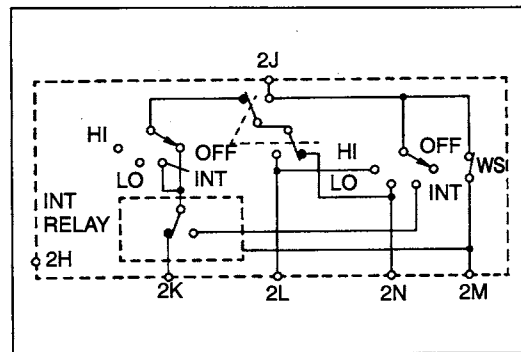
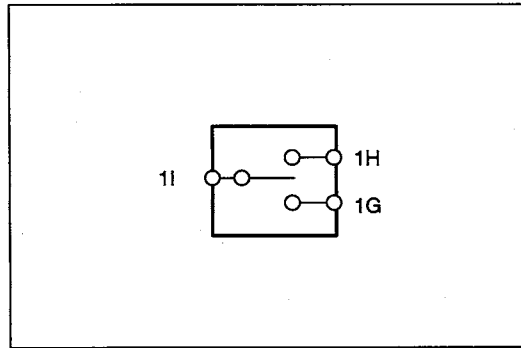
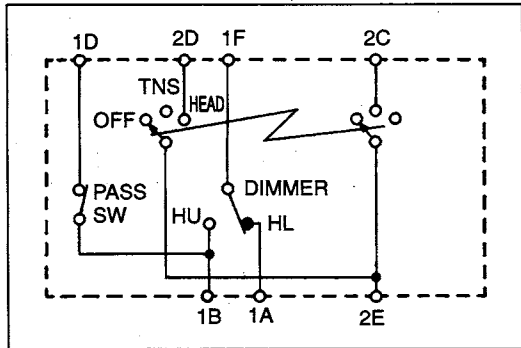
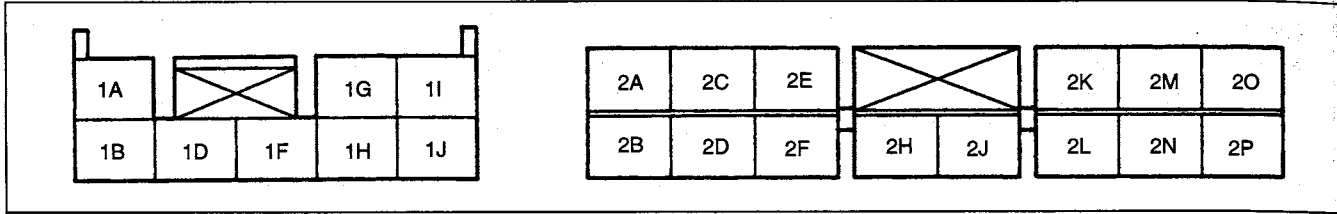

Headlight switch

○—○: Continuity

Light	Dimmer	Terminal Flash-to-pass	Terminal						
			2E	2C	2D	1F	1A	1B	1D
OFF	—	OFF							
		ON						○—○	
Parking	—	OFF	○—○						
		ON	○—○					○—○	
Headlight	LO	OFF	○—○	○—○		○—○			
		ON	○—○	○—○		○—○		○—○	
	HI	—	○—○	○—○		○—○		○—○	

Turn switch

○—○: Continuity

Switch position	Terminal		
	1I	1H	1G
Left	○—○	○—○	
OFF			
Right	○—○		○—○

Windshield wiper and washer switch

○—○: Continuity

Switch position	Terminal One-touch	Terminal				
		2K	2L	2N	2J	2M
Wiper switch	OFF	OFF	○—○		○—○	
		ON		○—○		○—○
	INT	○—○		○—○		
	LO			○—○		○—○
Washer switch	HI		○—○		○—○	
	ON				○—○	○—○

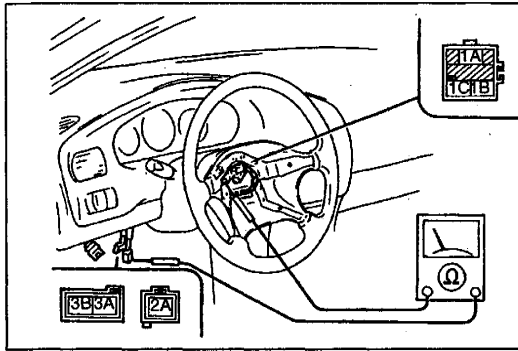

Clock spring

Warning

- Handling the air bag module improperly can accidentally deploy the air bag, which may seriously injure you. Read **SERVICE WARNINGS**, page T1-98, before handling the air bag module.

1. Remove the driver-side air bag module. (Refer to page T1-107.)
2. Check for continuity between the terminals of the clock spring connector.

○—○: Continuity

Step	Terminal	1A	1B	1C	2A	3A	3B
1		○			○		
2			○			○	
3				○			○

Note

- When terminals 3A and 3B are disconnected from the vehicle's main harness, they are shorted to prevent unexpected air bag deployment.

3. If not as specified, replace the combination switch. (Refer to page T1-21.)

Without air bag system

1. Check for continuity between the terminals as indicated below.
2. If not as specified, replace the necessary parts.

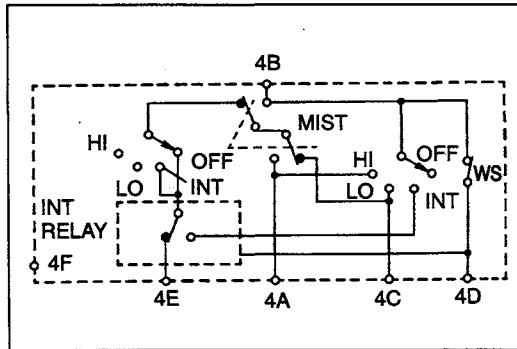
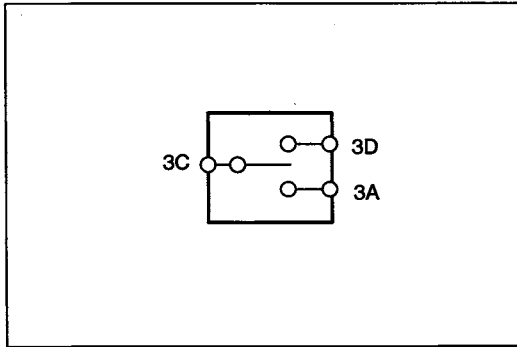
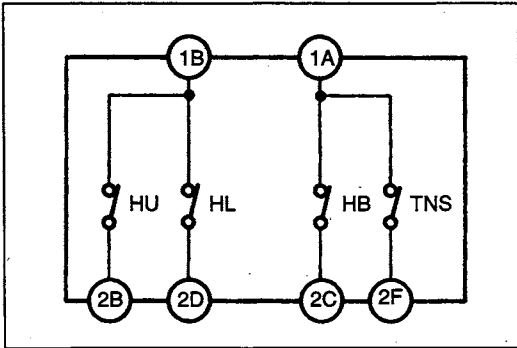
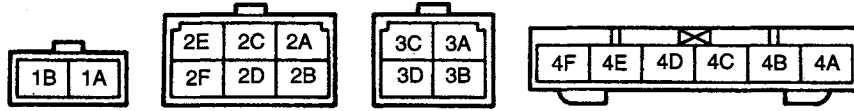

Headlight switch

○—○: Continuity

Light	Dimmer	Flash-to-pass	Terminal					
			1B	2B	2D	1A	2F	2C
OFF	—	OFF						
		ON	○—○					
Parking	—	OFF				○—○	○—○	
		ON	○—○			○—○	○—○	
Headlight	LO	OFF	○—○	○—○	○—○	○—○	○—○	○—○
		ON	○—○	○—○		○—○	○—○	○—○
	HI	—	○—○	○—○		○—○	○—○	○—○

Turn switch

○—○: Continuity

Switch position	Terminal		
	3C	3A	3D
Left	○—○	○—○	
OFF			
Right	○—○		○—○

Windshield wiper and washer switch

○—○: Continuity

Switch position	One-touch	Terminal				
		4E	4A	4C	4B	4D
Wiper switch	OFF	○—○		○—○		
	ON		○—○		○—○	
	INT	○—○		○—○		
	LO			○—○	○—○	
Washer switch	HI		○—○		○—○	
	ON				○—○	○—○

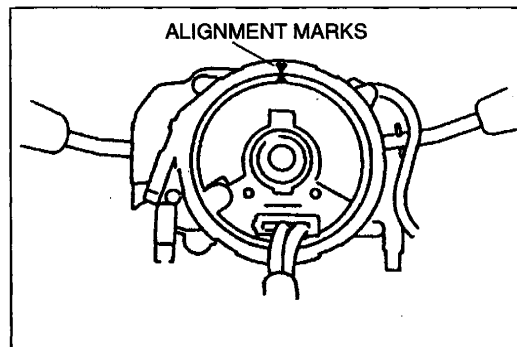
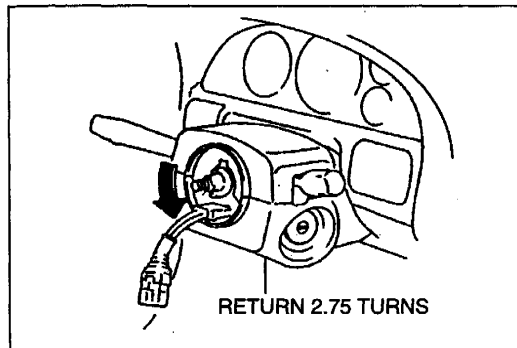
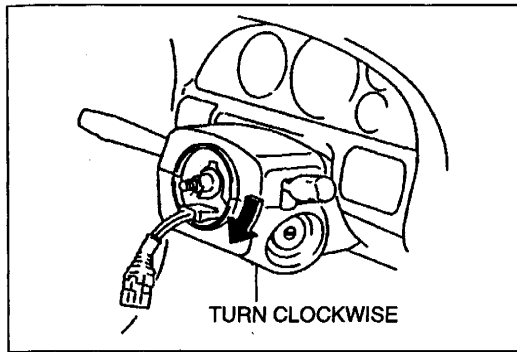

Adjustment Clock spring

Before installing the steering wheel, adjust the clock spring.

1. Set the front wheels straight ahead.
2. Turn the clock spring clockwise until it stops. Do not force it.

3. Turn the clock spring counterclockwise 2.75 turns.

4. Align the mark on the clock spring connector with that on the outer housing.

HAZARD WARNING SWITCH

Removal / Installation

1. Remove the meter hood.
(Refer to section S1.)
2. Remove in the order shown in the figure.
3. Install in the reverse order of removal.

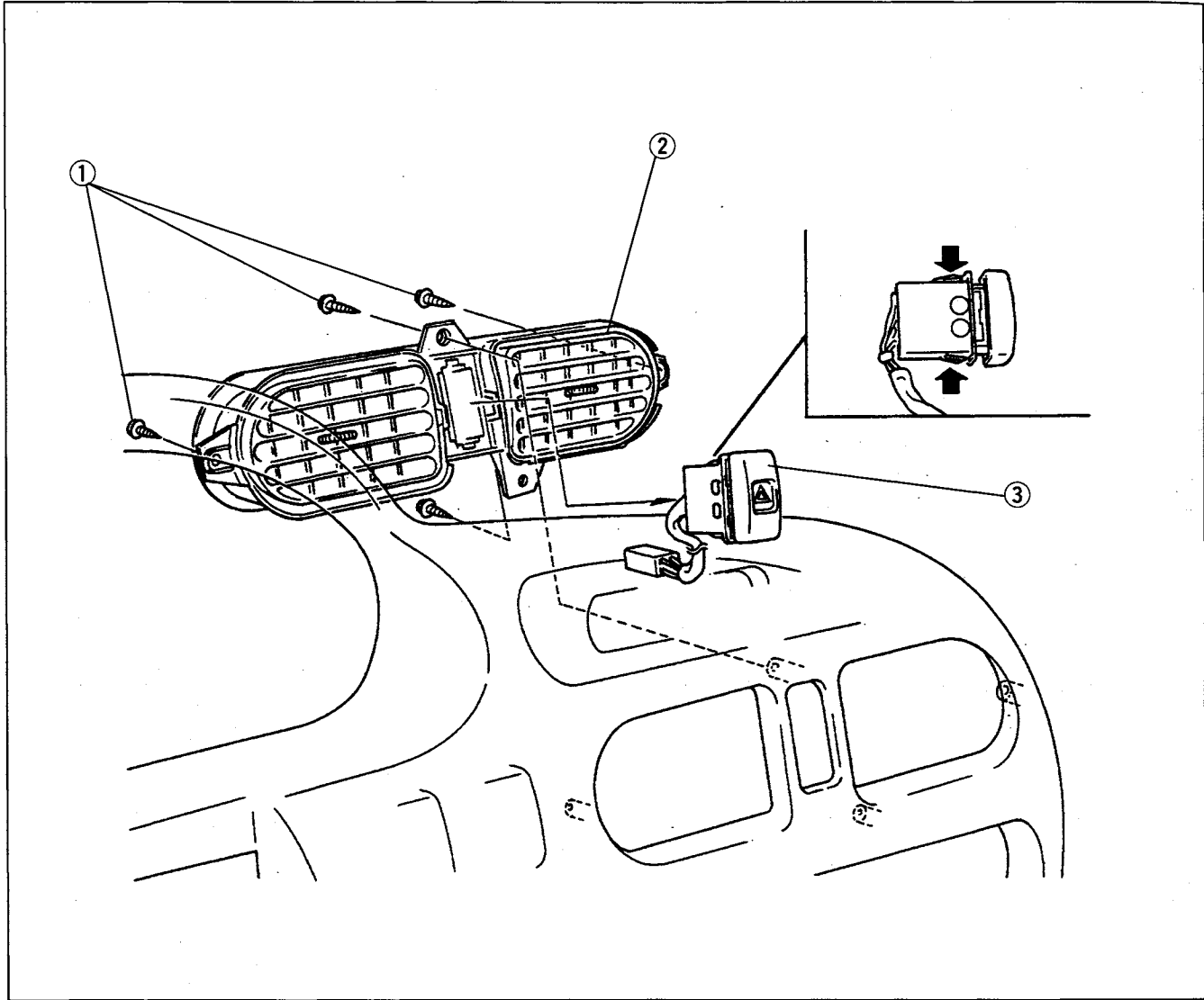

1. Screws
2. Louver ventilation grille

3. Hazard warning switch

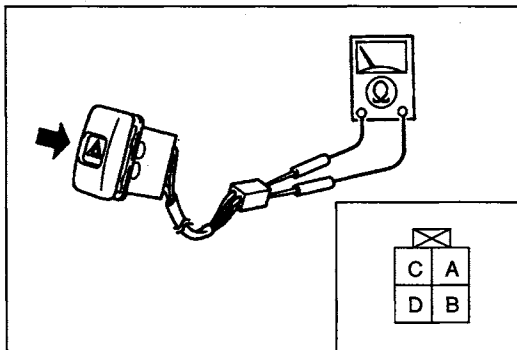

Inspection

1. Remove the hazard warning switch.
2. Check for continuity between the switch terminals as indicated below.

○—○ : Continuity ○—⊕—○ : Bulb

Switch position \ Terminal	A	B	C	D
OFF	○—⊕—○			
ON	○—○	○—○	○—○	○—○

3. If not as specified, replace the hazard warning switch.

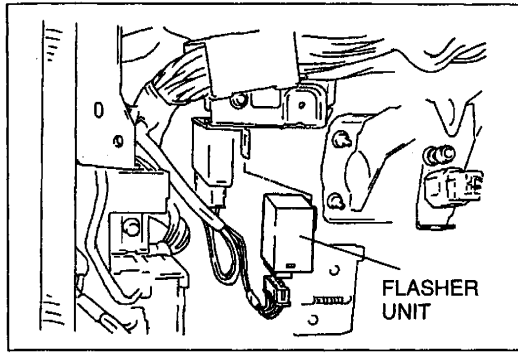

FLASHER UNIT

Removal / Installation

1. Remove the lower panel.
(Refer to section S1.)
2. Disconnect the flasher unit connector.
3. Remove the flasher unit.
4. Install in the reverse order of removal.

Inspection

1. Remove the lower panel.
(Refer to section S1.)
2. Measure the voltage at the flasher unit terminals as indicated below.
3. If not as specified, inspect the parts listed under "Inspection area" and the related wiring harnesses.
4. If the parts and wiring harnesses are OK but the system still does not work properly, replace the flasher unit.

Terminal voltage list (Reference)

B+: Battery positive voltage

Terminal	Connection	Test condition	Voltage	Inspection area
A	GND	Constant: check for continuity to ground	Yes	GND
B	—	—	—	—
C	Hazard warning switch	Hazard warning switch: on	0 V	Hazard warning switch
		Hazard warning switch: off	B+	
D	Turn signal light (LH)	Turn signal light (LH) flashes	Alternates 0 V and B+	Turn signal light (LH)
		Other	0 V	
E	Turn switch (RH)	Ignition switch and turn switch (RH): on	B+	Turn switch (RH)
		Other	0 V	
F	Turn switch (LH)	Ignition switch and turn switch (LH): on	B+	Turn switch (LH)
		Other	0 V	
G	Turn signal light (RH)	Turn signal light (RH) flashes	Alternates 0 V and B+	Turn signal light (RH)
		Other	0 V	
H	B+	Constant	B+	HAZARD 15 A fuse

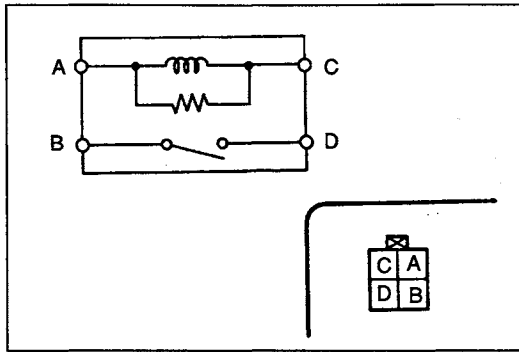

HEADLIGHT RELAY

Inspection

1. Apply battery positive voltage and check for continuity between the relay terminals.

○—○: Continuity B+: Battery positive voltage

Step	Terminal	A	C	B	D
1		○—○			
2		GND	B+	○—○	

2. If not as specified, replace the headlight relay.

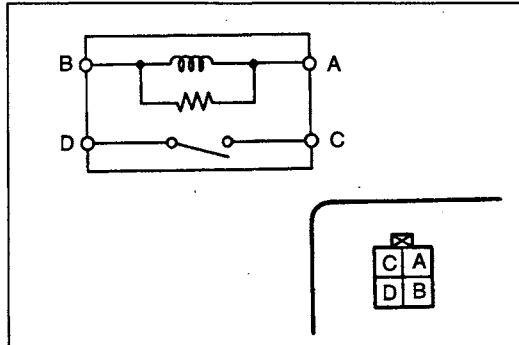

TNS RELAY

Inspection

1. Apply battery positive voltage and check for continuity between the relay terminals.

○—○: Continuity B+: Battery positive voltage

Step	Terminal	A	B	C	D
1		○—○			
2		GND	B+	○—○	

2. If not as specified, replace the TNS relay.

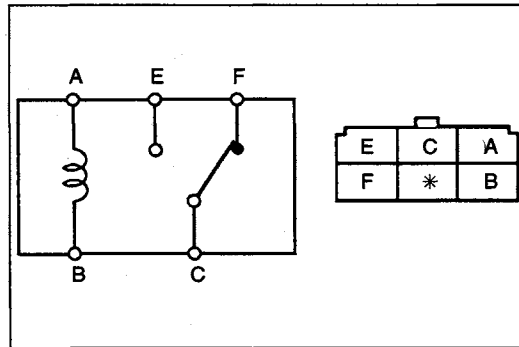

DRL RELAY

Inspection

1. Apply battery positive voltage and check for continuity between the relay terminals.

○—○: Continuity B+: Battery positive voltage

Step	Terminal	A	B	C	F	E
1		○—○		○—○		
2		B+	GND	○—○		○—○

2. If not as specified, replace the DRL relay.

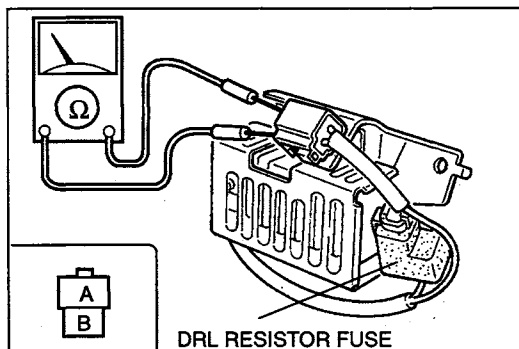

DRL RESISTOR

Inspection

1. Check for continuity between terminals A and B of the DRL resistor.
2. If there is no continuity, replace the DRL resistor or DRL resistor fuse.

Resistance: 0.3 Ω

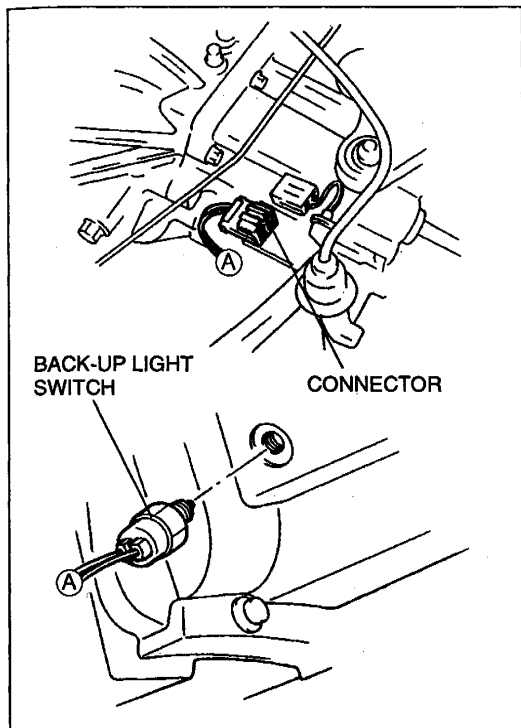

BACK-UP LIGHT SWITCH

Removal / Installation

1. Disconnect the back-up light switch connector.
2. Remove the splash shield.
(Refer to section B.)
3. Remove the back-up light switch.
4. Install in the reverse order of removal.

Tightening torque:

20—29 N·m { 2.0—3.0 kgf·m , 15—21 ft·lbf }

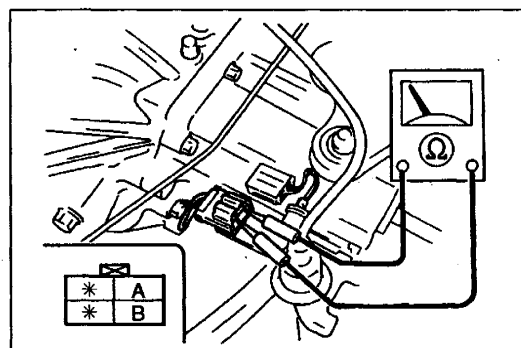

Inspection

1. Disconnect the back-up light switch connector.
2. Check for continuity between switch terminals A and B.

Shift lever position	Continuity
Reverse	Yes
Other	No

3. If not as specified, replace the back-up light switch.

INTERIOR LIGHTING SYSTEM

STRUCTURAL VIEW

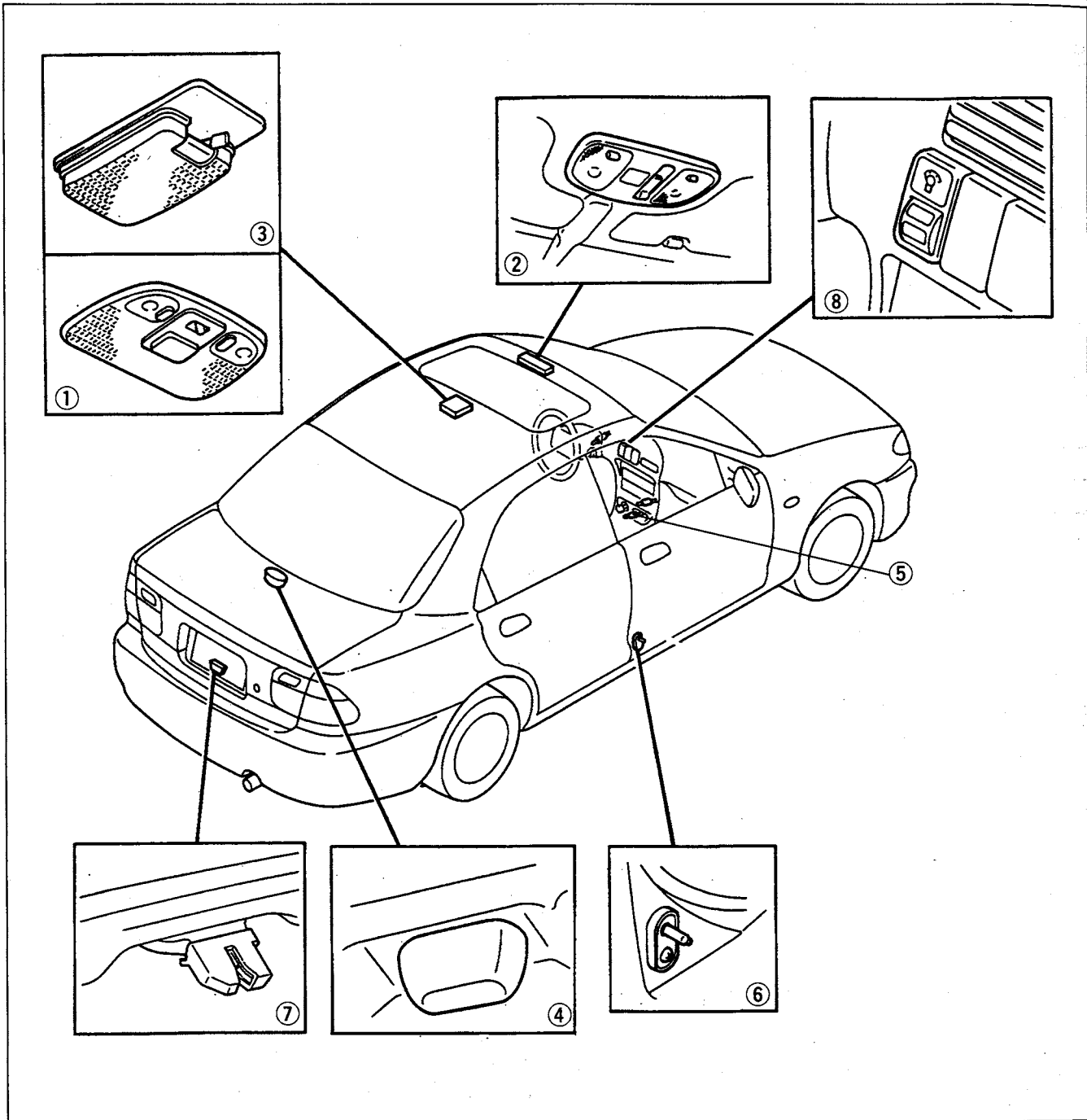

- | | | | |
|--|------------|---|------------|
| 1. Interior and spot light
Removal / Installation | page T1-33 | 5. Front ashtray illumination
Bulb replacement | page T1-36 |
| 2. Spot light
Removal / Installation | page T1-34 | 6. Door switch
Removal / Installation | page T1-36 |
| 3. Interior light
Removal / Installation | page T1-35 | Inspection | page T1-36 |
| 4. Trunk compartment light
Bulb replacement | page T1-36 | 7. Trunk compartment light switch
Inspection | page T1-37 |
| | | 8. Panel light control switch
Removal / Installation | page T1-37 |

**INTERIOR AND SPOT LIGHT
Removal / Installation**

1. Remove in the order shown in the figure, referring to **Removal note**.
2. Install in the reverse order of removal.

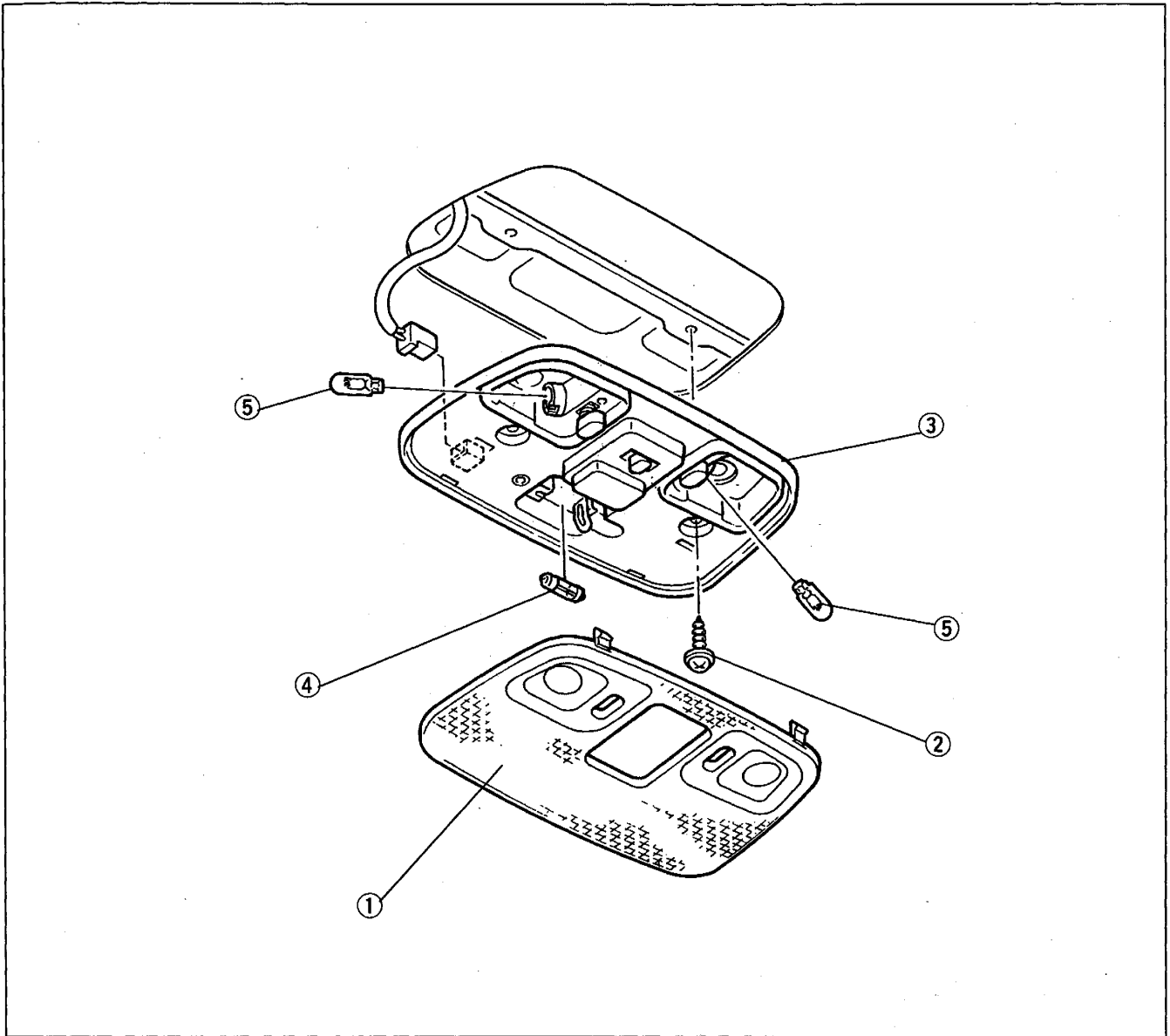

- | | | |
|----------|--------------------------|-------------------|
| 1. Lens | | 3. Housing |
| 2. Screw | Removal note below | 4. Bulb (10 W) |
| | | 5. Bulb (5 W × 2) |

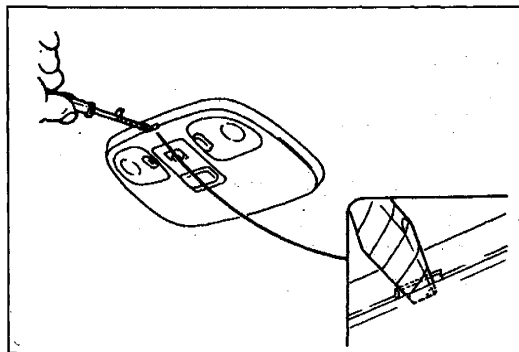

Removal note

Lens

1. Insert a flathead screwdriver which has been wrapped in tape into the service hole between the lens and the housing.
2. Twist the screwdriver to remove the lens.

SPOT LIGHT

Removal / Installation

1. Remove in the order shown in the figure, referring to **Removal note**.
2. Install in the reverse order of removal.

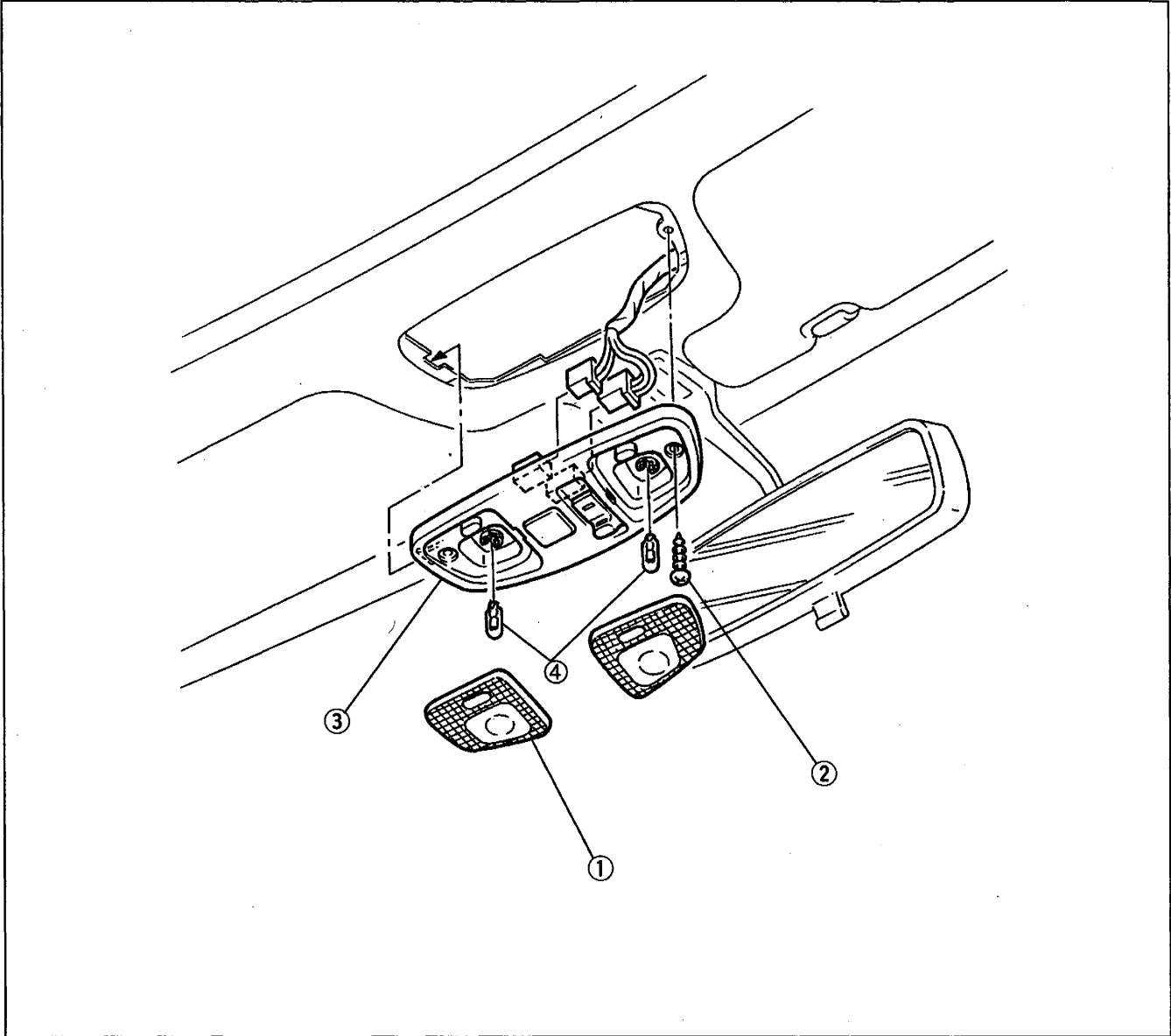

- | | |
|----------|--------------------|
| 1. Lens | 3. Housing |
| 2. Screw | 4. Bulbs (5 W × 2) |
- Removal note below

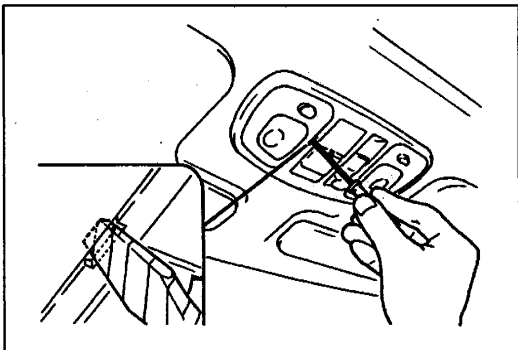

Removal note

Lens

1. Insert a flathead screwdriver which has been wrapped in tape into the service hole between the lens and the housing.
2. Twist the screwdriver to remove the lens.

INTERIOR LIGHT
Removal / Installation

1. Remove in the order shown in the figure, referring to **Removal note**.
2. Install in the reverse order of removal.

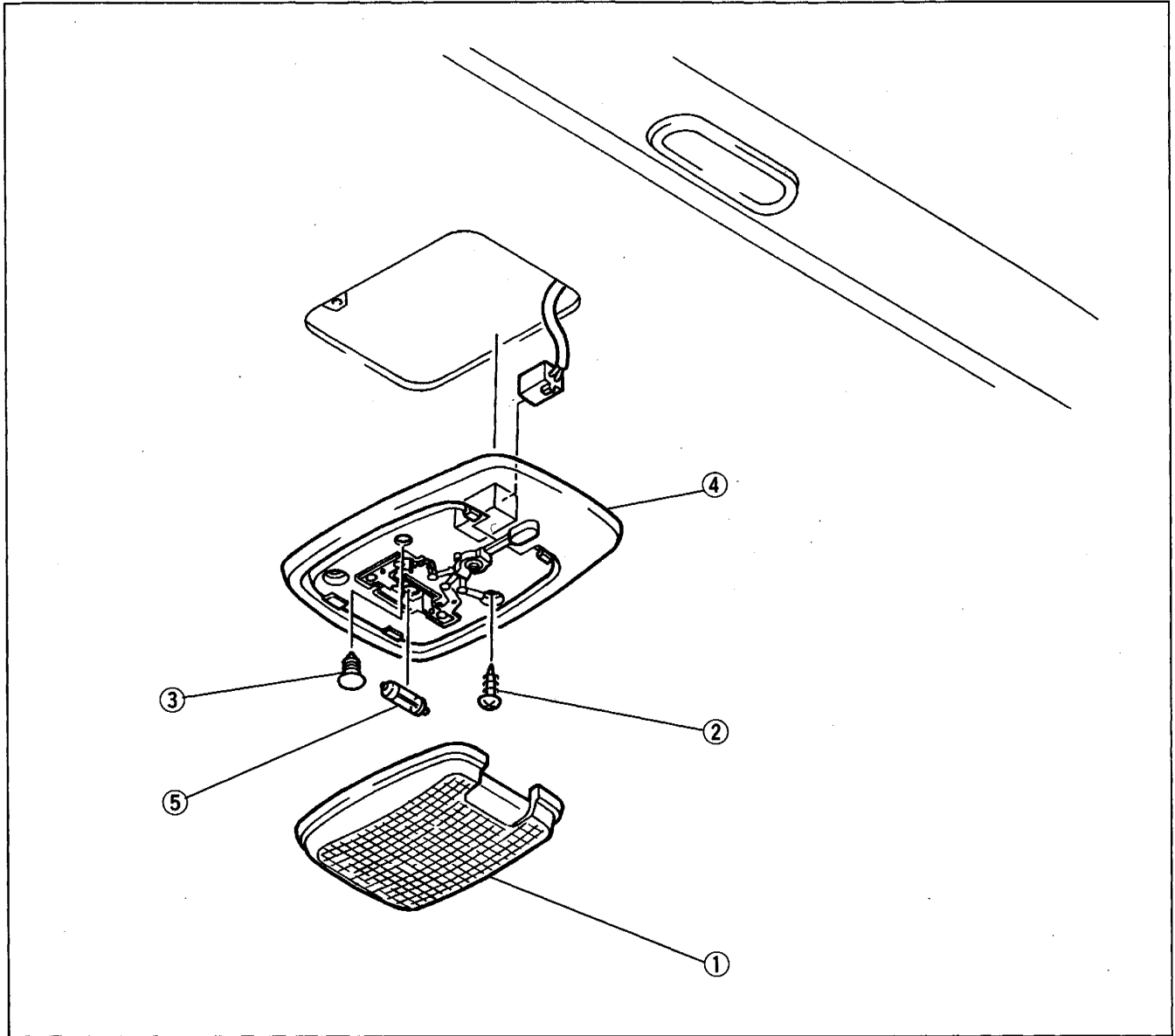

- | | | |
|----------|--------------------------|----------------|
| 1. Lens | | 3. Fastener |
| 2. Screw | Removal note below | 4. Housing |
| | | 5. Bulb (10 W) |

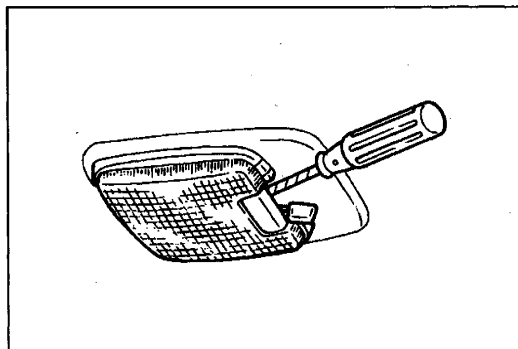

Removal note
Lens

1. Insert a flathead screwdriver which has been wrapped in tape as shown in the figure.
2. Twist the screwdriver to remove the lens.

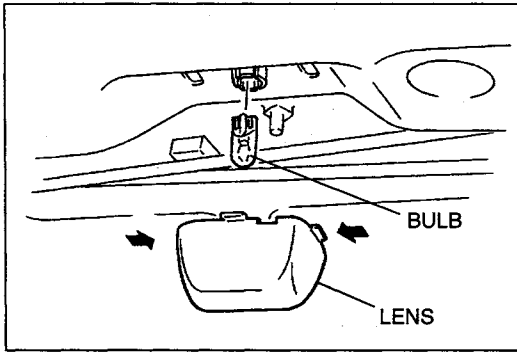

TRUNK COMPARTMENT LIGHT

Bulb Replacement

1. Push the sides of the lens and pull to remove it.
2. Remove the trunk compartment light bulb.
3. Install in the reverse order of removal.

Trunk compartment light bulb: 5 W

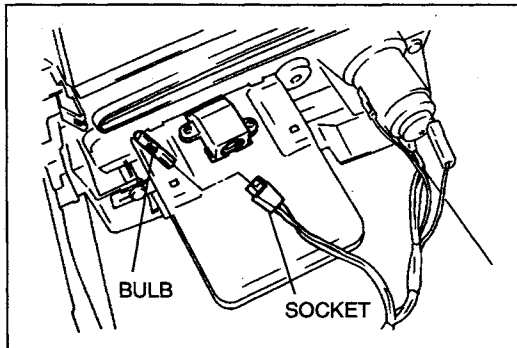

FRONT ASHTRAY ILLUMINATION

Bulb Replacement

1. Remove the front console.
(Refer to section S1.)
2. Remove the socket and remove the front ashtray illumination bulb.
3. Install in the reverse order of removal.

Front ashtray illumination bulb: 1.4 W

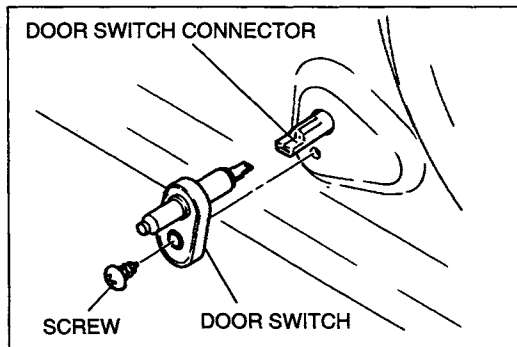

DOOR SWITCH

Removal / Installation

1. Remove the screw and remove the door switch.
2. Disconnect the door switch connector and remove the door switch.
3. Install in the reverse order of removal.

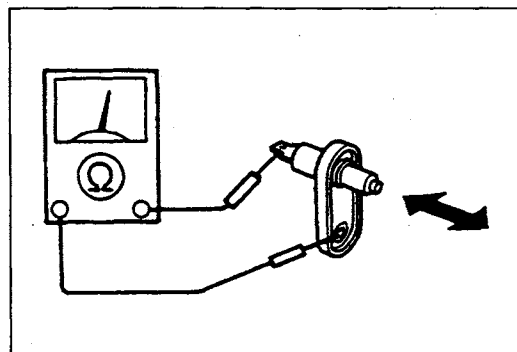

Inspection

1. Remove the door switch.
2. Check for continuity between the switch terminal and the switch body as shown in the figure.

Switch condition	Continuity
Pressed	No
Released	Yes

3. If not as specified, replace the door switch.

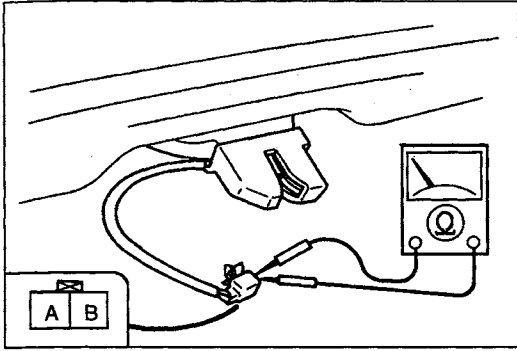

TRUNK COMPARTMENT LIGHT SWITCH

Inspection

1. Remove the trunk lid trim.
(Refer to section S1.)
2. Disconnect the trunk compartment light switch connector.
3. Check for continuity between terminals A and B of the trunk compartment light switch.

Switch condition	Continuity
Pressed (Trunk lid closed)	No
Released (Trunk lid open)	Yes

4. If not as specified, replace the trunk lid lock.
(Refer to section S1.)

PANEL LIGHT CONTROL SWITCH

Removal / Installation

1. Remove the meter hood.
(Refer to section S1.)
2. Remove in the order shown in the figure, referring to **Removal note**.
3. Install in the reverse order of removal.

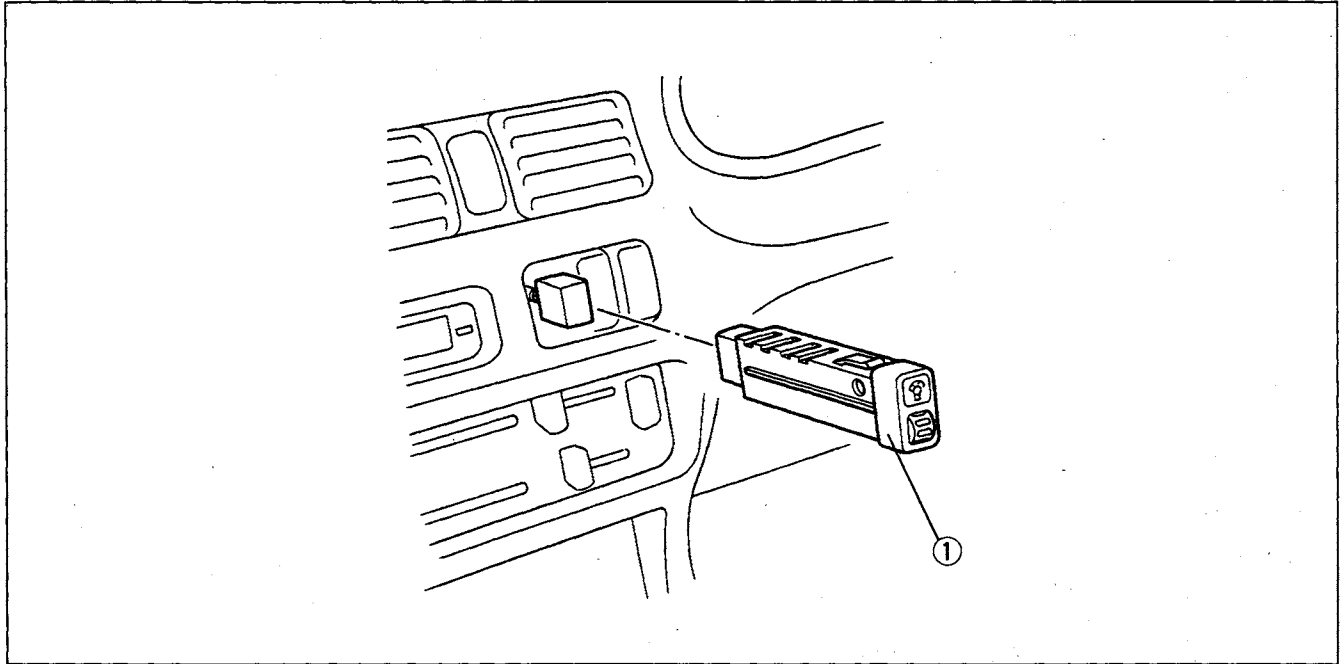

1. Panel light control switch
Removal note below

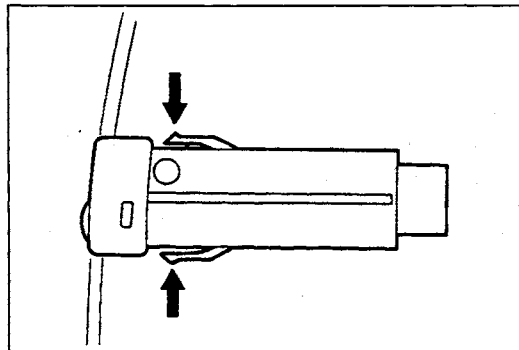

Removal note

Panel light control switch

Push the sides of the switch and pull to remove it.

WINDSHIELD WIPER AND WASHER

STRUCTURAL VIEW

Windshield Wiper and Washer System

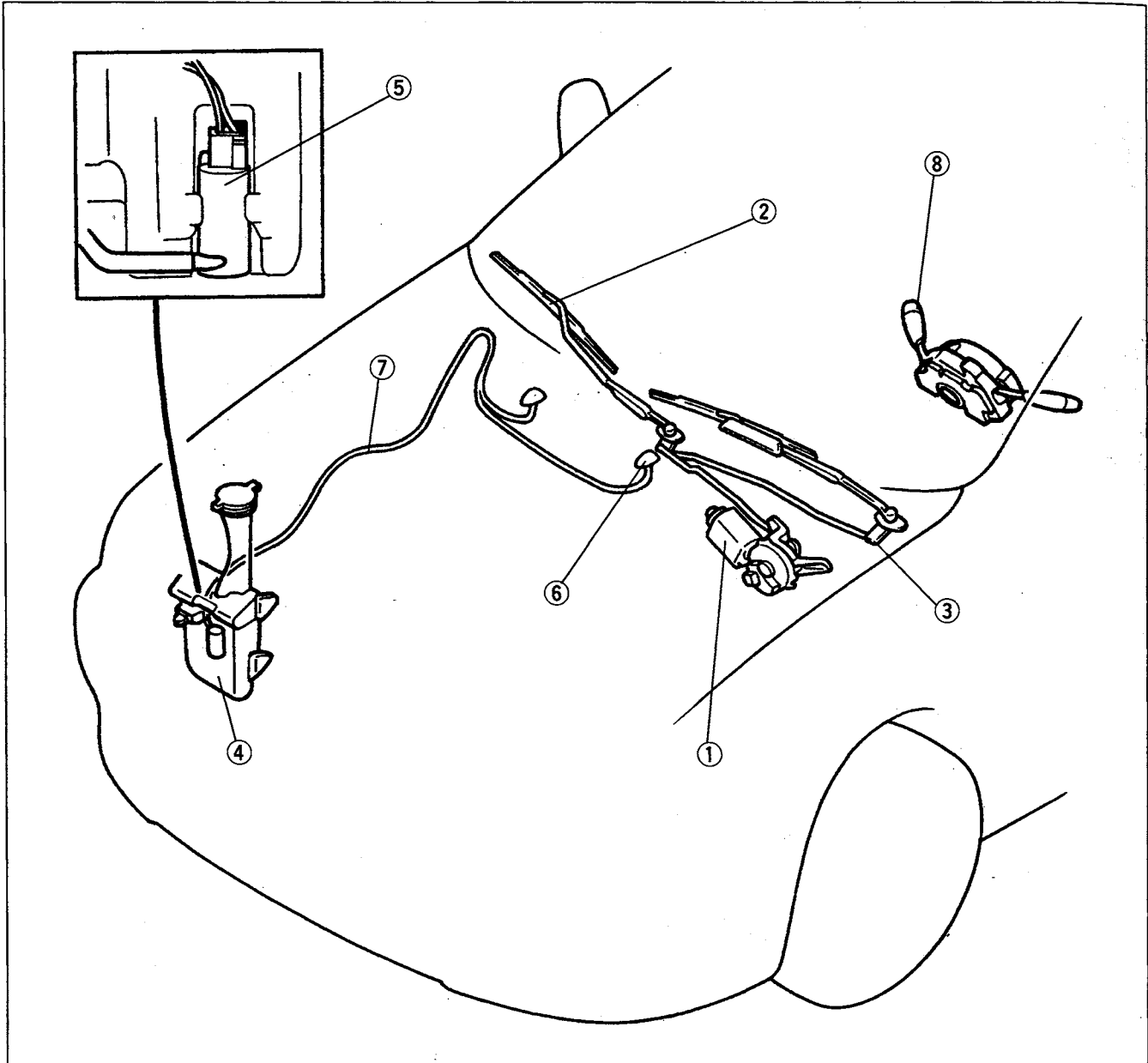

- 1. Windshield wiper motor
 - Removal / Installation page T1-39
 - Disassembly / Assembly page T1-40
 - Inspection page T1-41
- 2. Windshield wiper arm and blade
 - Removal / Installation page T1-42
 - Adjustment page T1-43
- 3. Windshield wiper link
 - Removal / Installation page T1-44
- 4. Windshield washer tank
 - Removal / Installation page T1-45
- 5. Windshield washer motor
 - Removal / Installation page T1-45
 - Inspection page T1-45

- 6. Windshield washer nozzle
 - Removal page T1-46
 - Installation page T1-46
 - Adjustment page T1-47
- 7. Windshield washer pipe
 - Removal / Installation page T1-47
- 8. Combination switch
 - Removal / Installation page T1-21
 - Disassembly / Assembly page T1-23
 - Inspection page T1-24
 - Adjustment page T1-27

WINDSHIELD WIPER MOTOR

Removal / Installation

1. Remove the cowl grille.
(Refer to section S1.)
2. Remove in the order shown in the figure.
3. Install in the reverse order of removal.

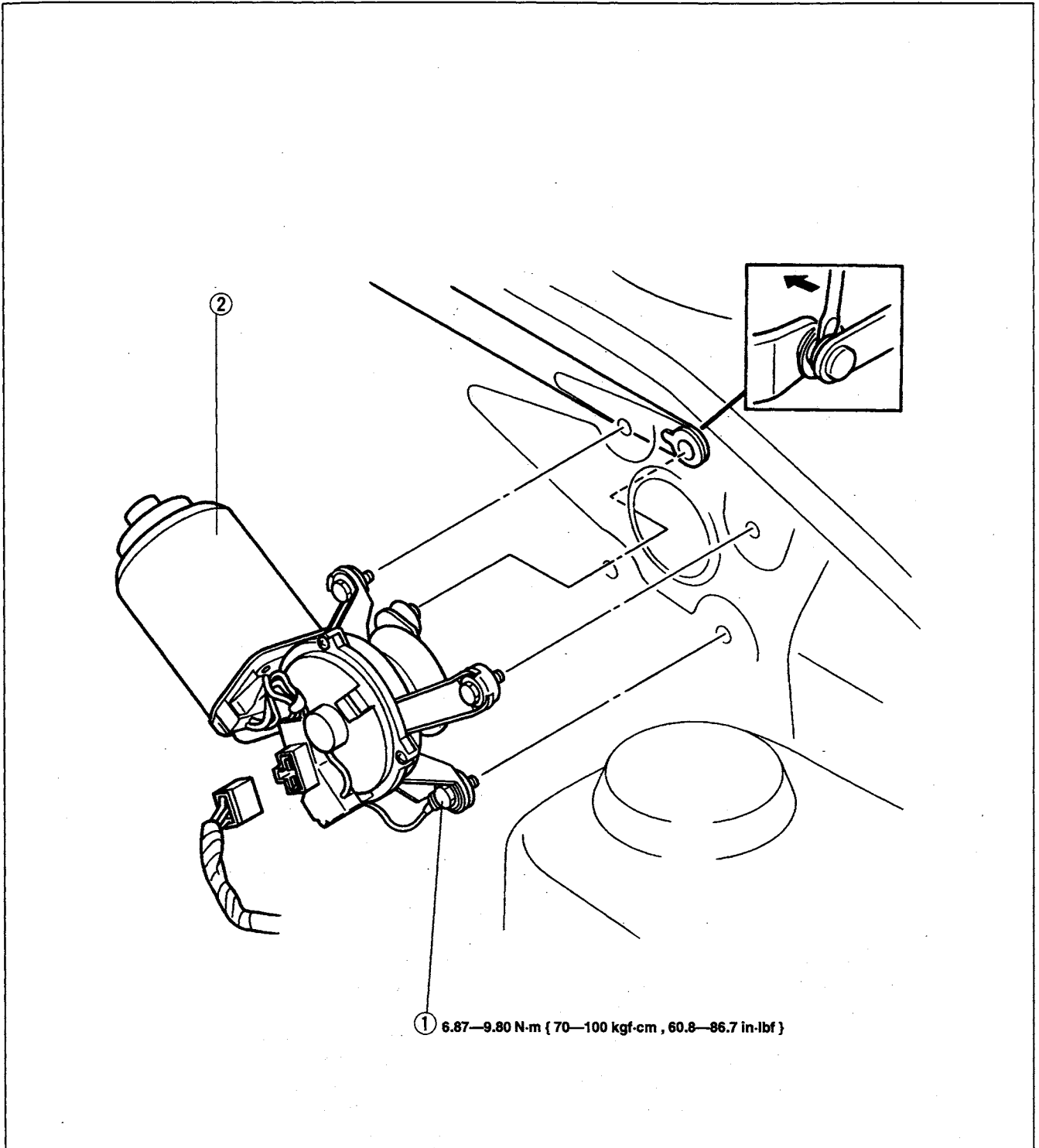

1. Bolt

2. Windshield wiper motor
Disassembly / Assembly page T1-40
Inspection page T1-41

Disassembly / Assembly

1. Remove the windshield wiper motor.
(Refer to page T1-39.)
2. Disassemble in the order shown in the figure.
3. Assemble in the reverse order of disassembly.

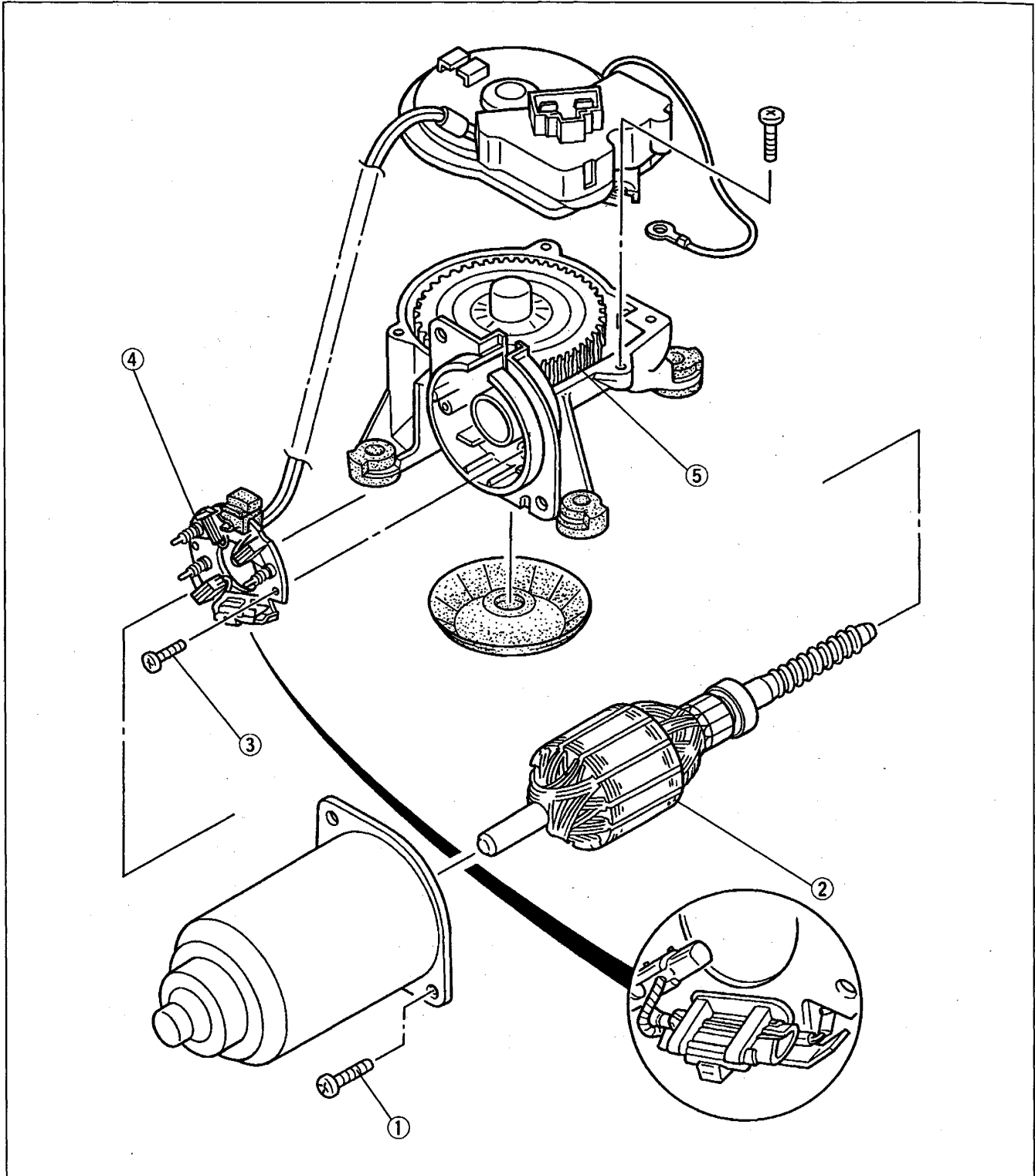

1. Screw
2. Armature
3. Screw

4. Brush plate holder
5. Motor gear shaft

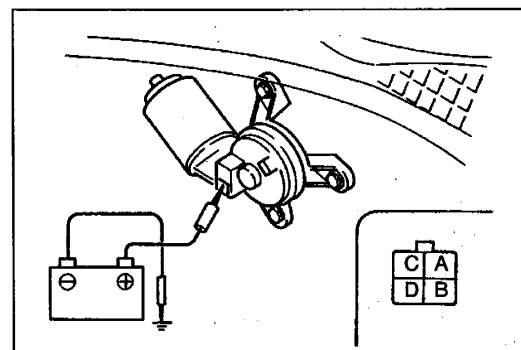
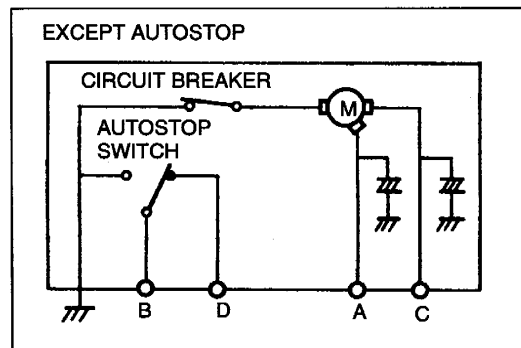
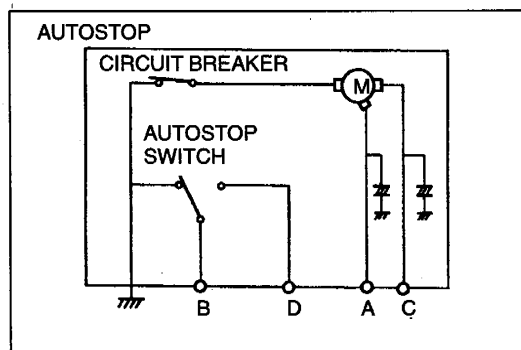
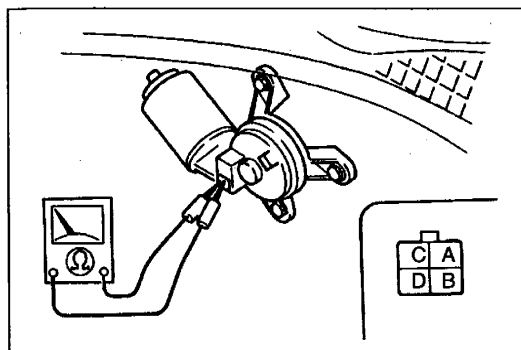

Inspection

1. Ignition switch is LOCK while the windshield wiper is operating.

Note

- Verify that the windshield wiper does not stop in the proper park position.

2. Disconnect the windshield wiper motor connector.
3. Check for continuity between the motor terminals as indicated below.

○—○: Continuity

Terminal	A	B	C	D
Autostop	○—○	○—○	○—○	

4. Connect the windshield wiper motor connector.
5. Wiper switch is OFF while windshield wiper is operating.

Note

- Verify that the windshield wiper stops in the park position.

6. Disconnect the windshield wiper motor connector.
7. Check for continuity between the motor terminals as indicated below.

○—○: Continuity

Terminal	A	B	C	D
Except autostop	○—○	○—○	○—○	○—○

8. Connect battery positive voltage to the terminals of the windshield wiper motor connector and ground to a bare metal part of the vehicle. Verify that the windshield wiper motor operates as indicated below.

Terminal	Operation speed
C	Low
A	High

9. If not as specified, replace the necessary parts. (Refer to page T1-40.)

WINDSHIELD WIPER ARM AND BLADE

Removal / Installation

1. Remove the cowl grille.
(Refer to section S1.)
2. Remove in the order shown in the figure.
3. Install in the reverse order of removal, referring to **Installation note**.

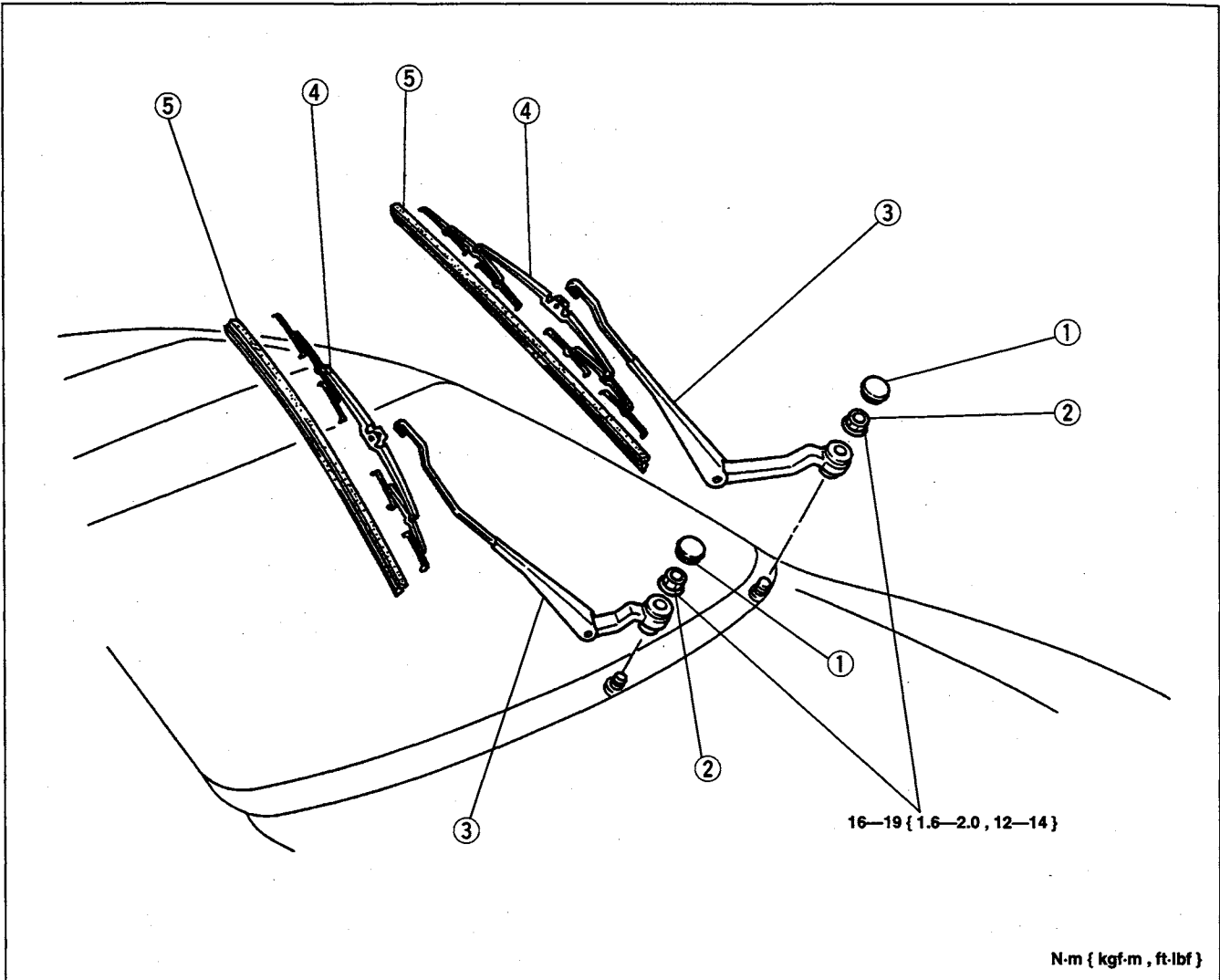

- | | |
|---|--|
| <ol style="list-style-type: none"> 1. Cap 2. Nut 3. Windshield wiper arm
Adjustment page T1-43
Installation note below | <ol style="list-style-type: none"> 4. Windshield wiper blade 5. Rubber brush |
|---|--|

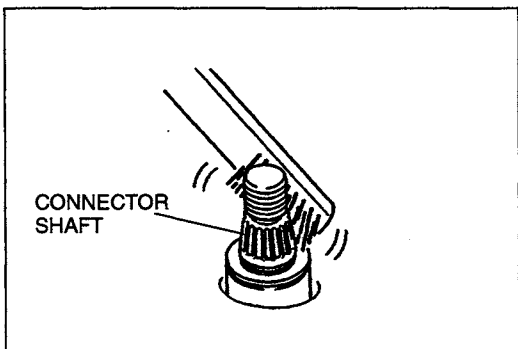

Installation note

Windshield wiper arm

Clean the wiper arm connector shafts with a wire brush before installing the wiper arms.

Adjustment

1. Operate the windshield wiper motor to set the wipers in the park position.
2. Set the arm height as shown.

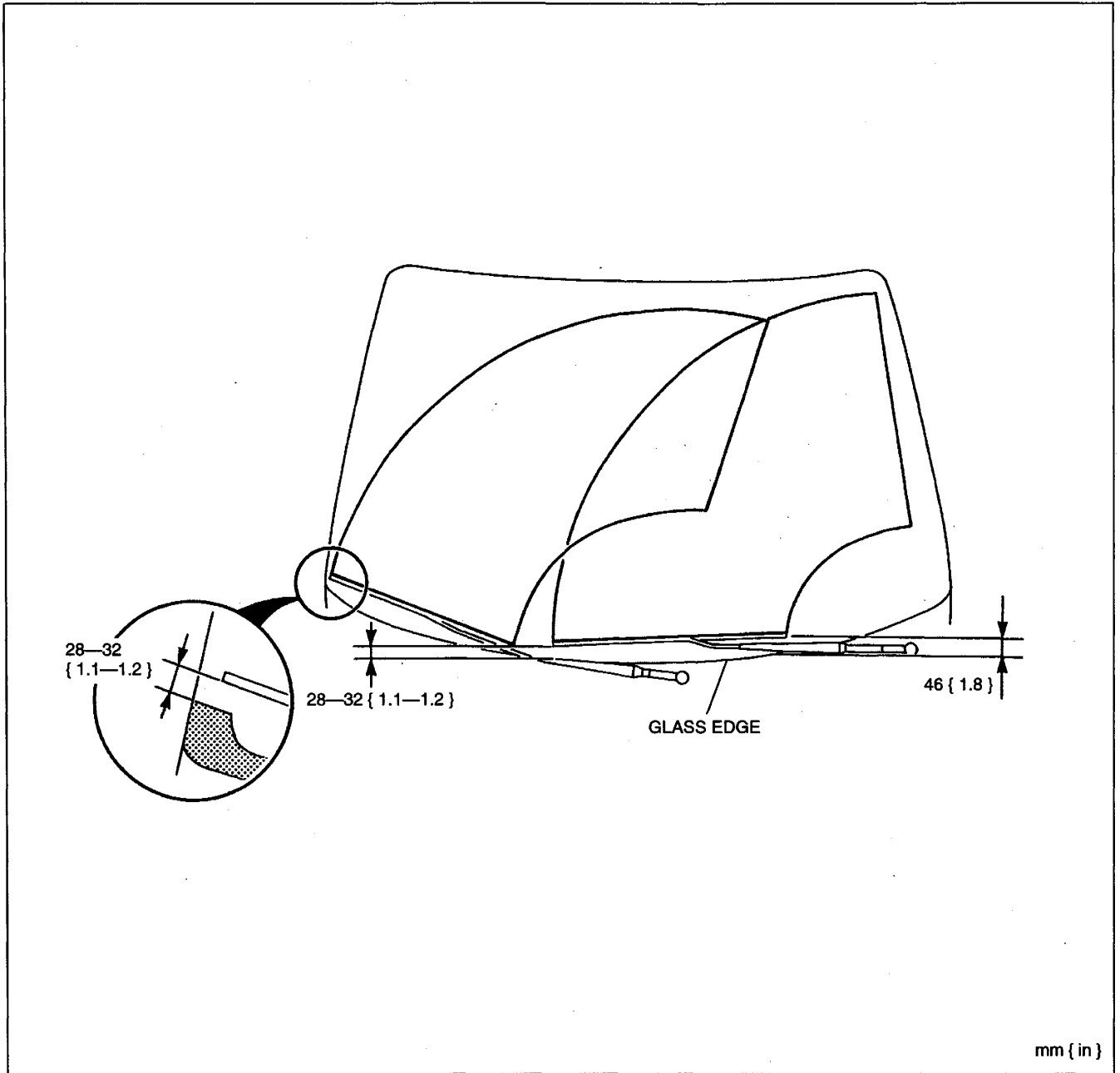

WINDSHIELD WIPER LINK**Removal / Installation**

1. Remove the windshield wiper arms.
(Refer to page T1-42.)
2. Remove the cowl grille.
(Refer to section S1.)
3. Remove in the order shown in the figure.
4. Install in the reverse order of removal.

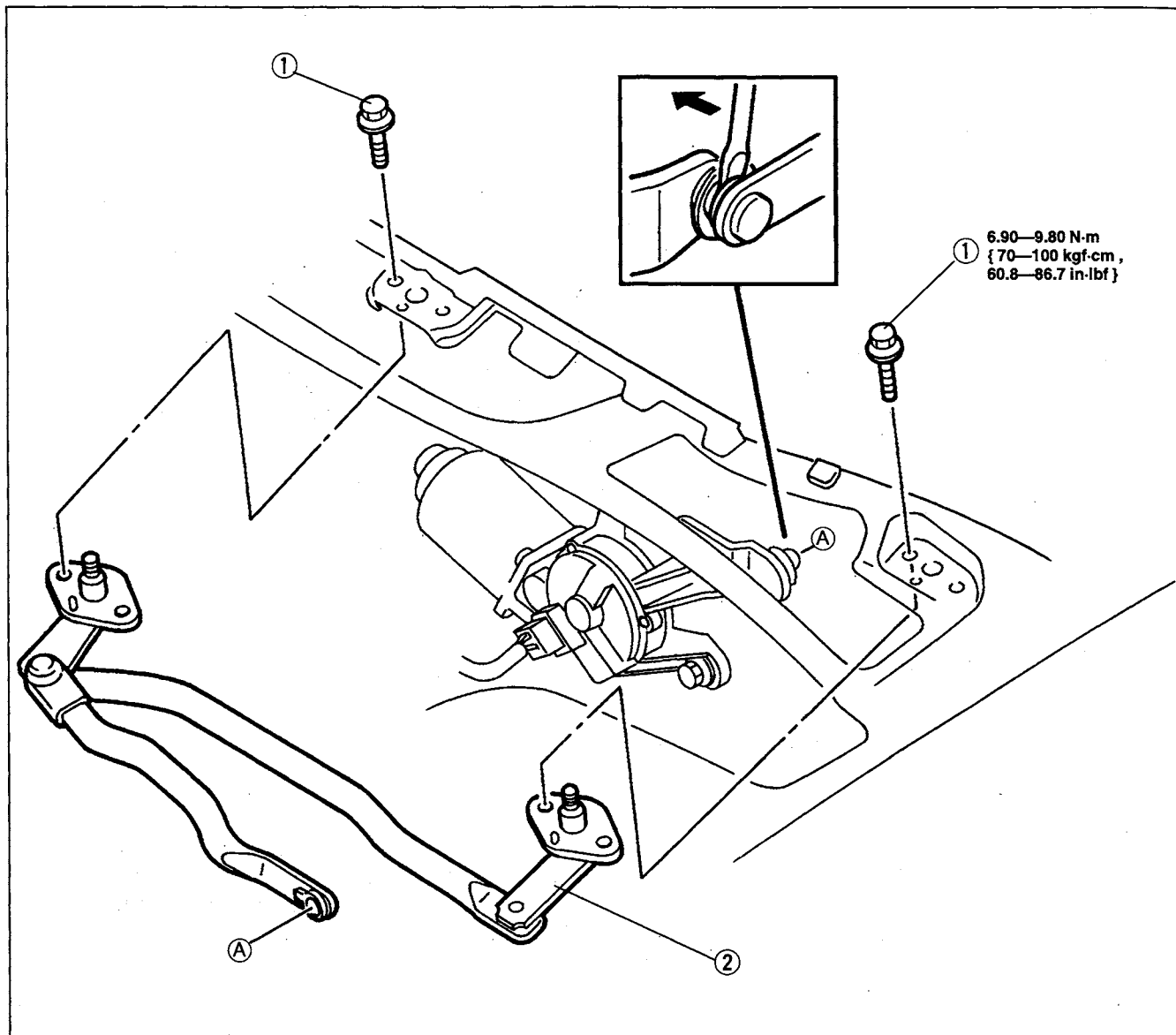

1. Bolt

2. Windshield wiper link

WINDSHIELD WASHER TANK

Removal / Installation

1. Remove the right mud guard.
(Refer to section S1.)
2. Remove in the order shown in the figure.
3. Install in the reverse order of removal.

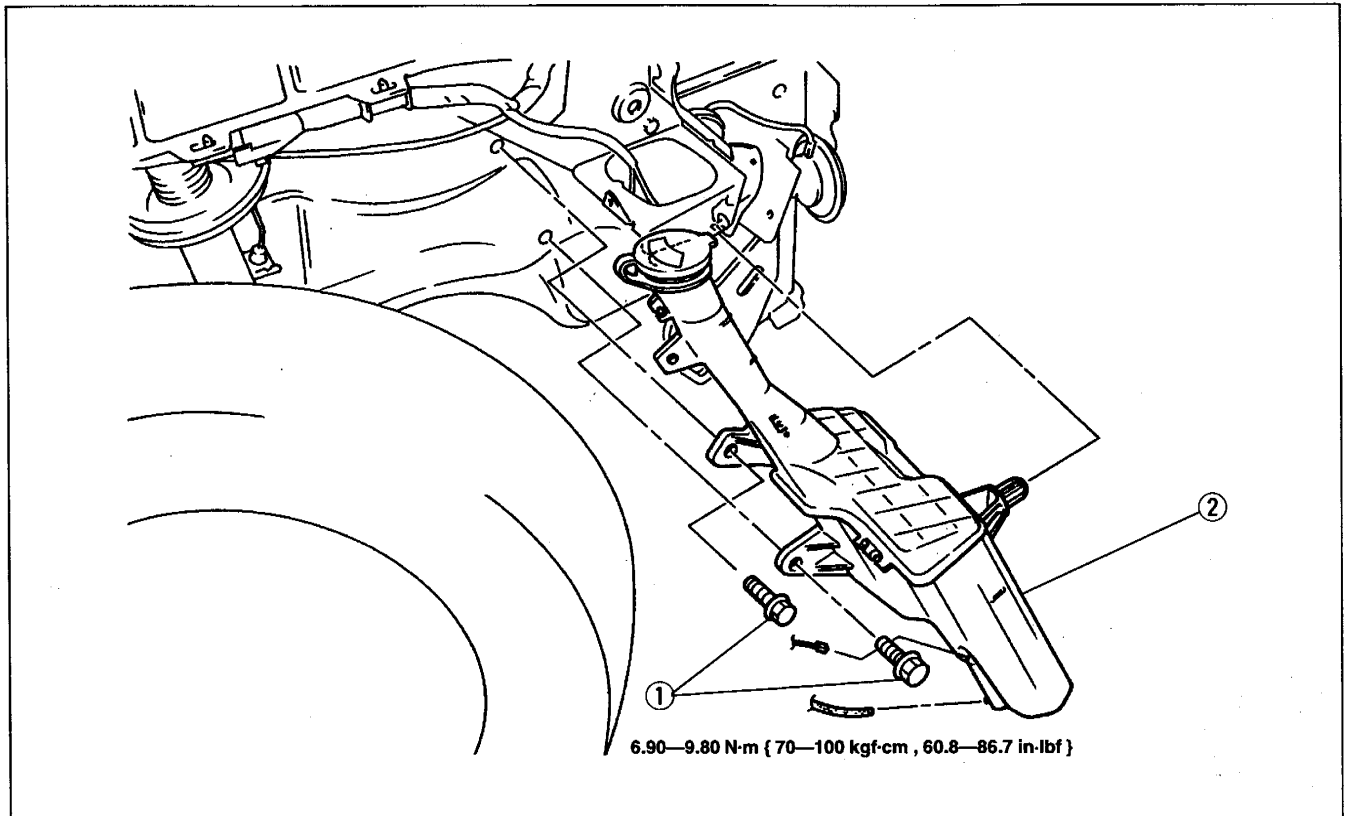

1. Bolts

2. Windshield washer tank

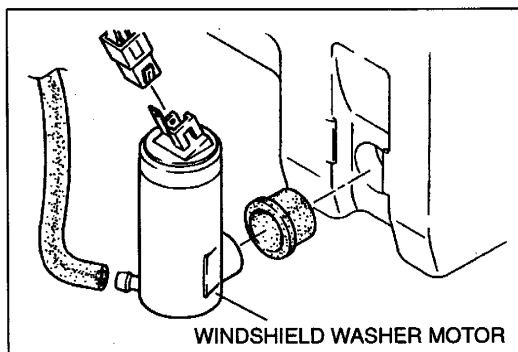

WINDSHIELD WASHER MOTOR

Removal / Installation

1. Remove the windshield washer tank.
2. Extract the washer fluid.
3. Remove the windshield washer motor as shown.
4. Install in the reverse order of removal.

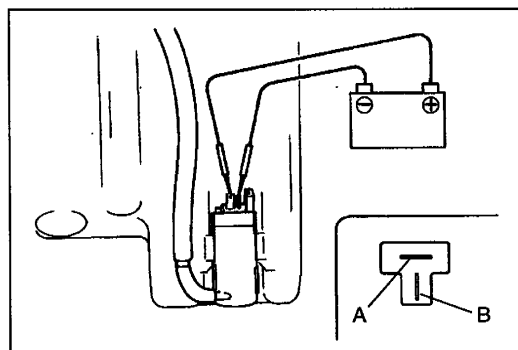

Inspection

1. Remove the right mud guard.
(Refer to section S1.)
2. Disconnect the windshield washer motor connector.
3. Connect battery positive voltage to terminal B and ground to terminal A of the motor.
4. Verify that the windshield washer motor operates.
5. If the motor does not operate, replace it.

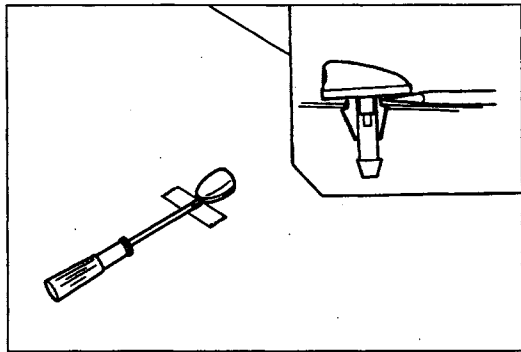
**WINDSHIELD WASHER NOZZLE****Removal**

1. Apply protective tape to the body around the washer nozzle.
2. Insert a flathead screwdriver which has been wrapped in tape under the rear of the nozzle and push the nozzle clip.

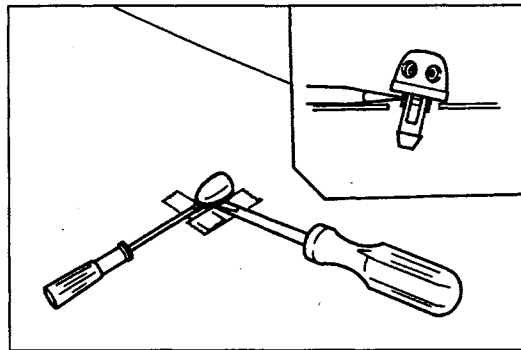

3. Insert another flathead screwdriver which has been wrapped in tape under the side of the nozzle.

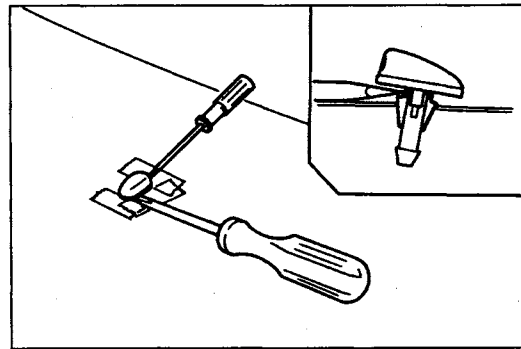

4. Remove the first screwdriver and insert it under the front of the nozzle.

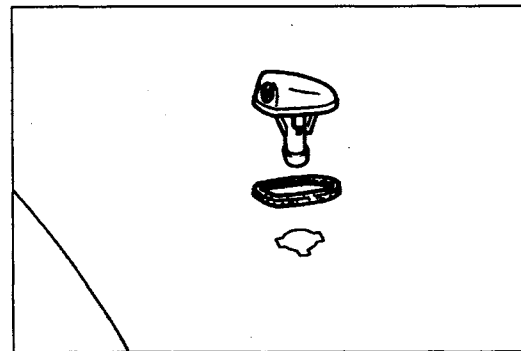

5. Disconnect the washer pipe from the washer nozzle to remove the nozzle.

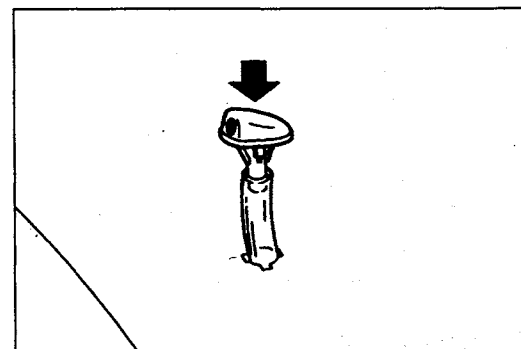
**Installation**

1. Connect the washer pipe to the washer nozzle.
2. Push the washer nozzle into the installation hole.

Adjustment

Adjust the windshield washer nozzle direction as shown in the figure by using a needle or equivalent tool.

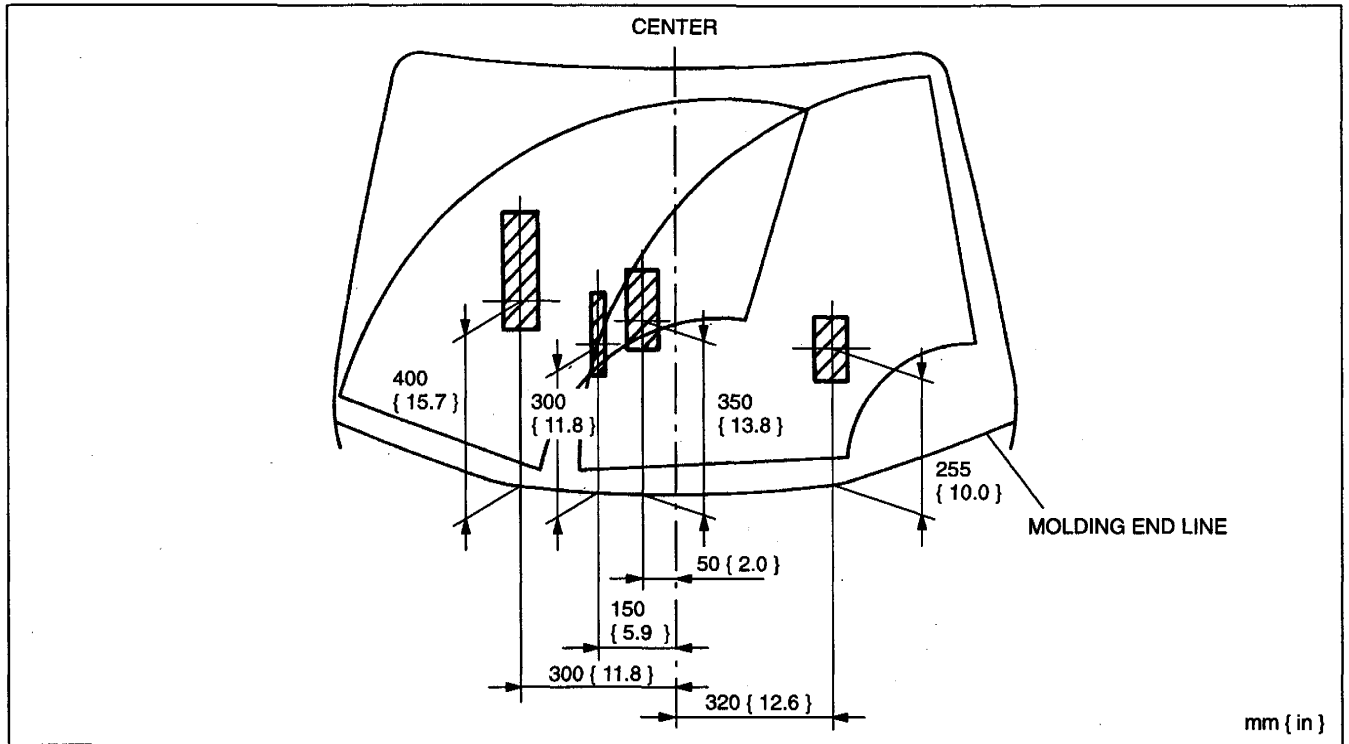

WINDSHIELD WASHER PIPE

Removal / Installation

1. Remove the hood insulator and mud guard.
(Refer to section S1.)
2. Remove in the order shown in the figure.
3. Install in the reverse order of removal.

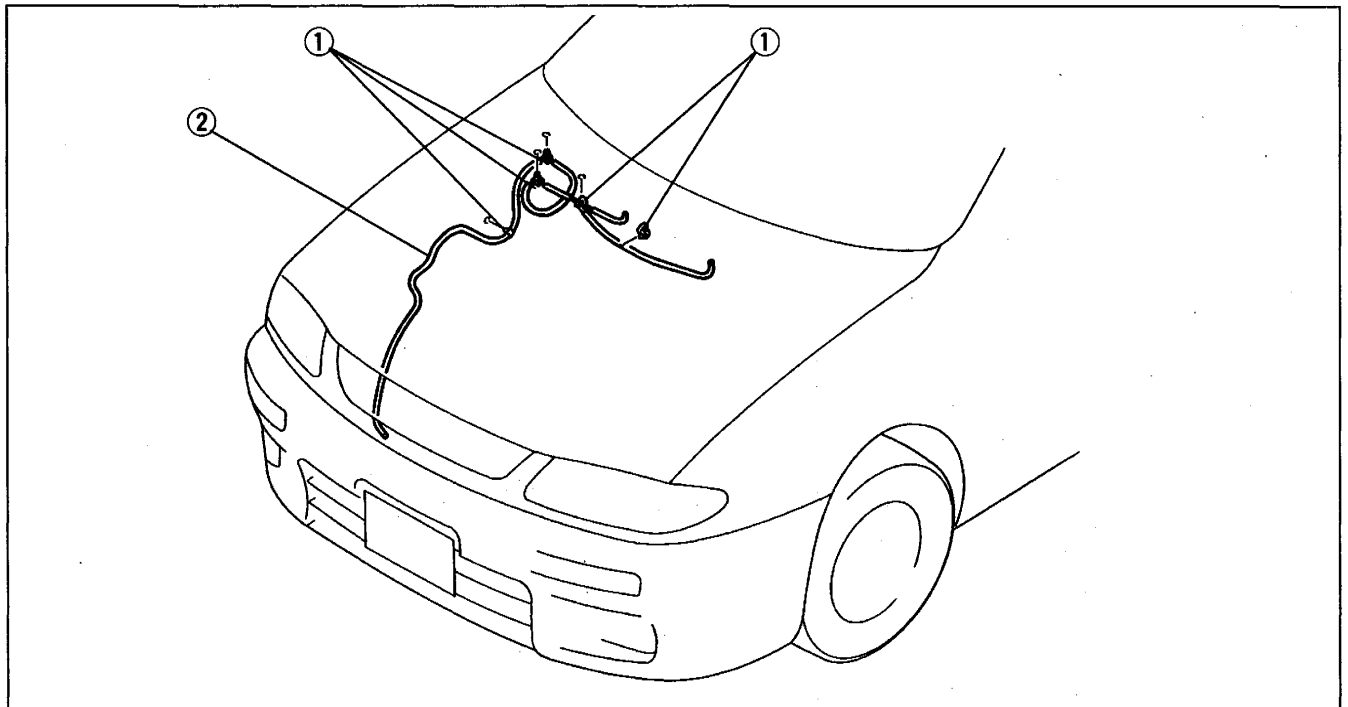



1. Clips

2. Windshield washer pipe

INSTRUMENT CLUSTER

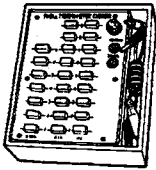
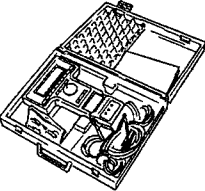
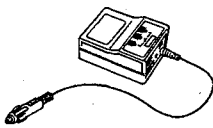
PREPARATION SST

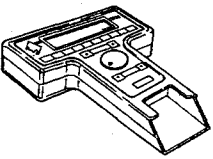
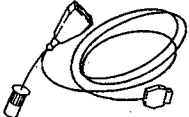
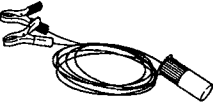
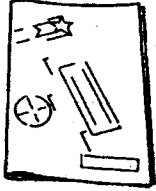
<p>49 0839 285</p> <p>Checker, fuel thermometer</p>		<p>For inspection of fuel and water temperature gauges</p>	<p>49 T088 0A0</p> <p>NGS set</p>	 <p>For inspection of tachometer</p>
<p>49 T088 002</p> <p>Vehicle Interface Module (Part of 49 T088 0A0)</p>		<p>For inspection of tachometer</p>	<p>49 T088 010B</p> <p>Program Card</p>	 <p>For inspection of tachometer</p>
<p>49 T088 001</p> <p>Control Unit (Part of 49 T088 0A0)</p>		<p>For inspection of tachometer</p>	<p>49 T088 004</p> <p>NGS OBDII Adapter (Part of 49 T088 0A0)</p>	 <p>For inspection of tachometer</p>
<p>49 T088 006</p> <p>Battery Hookup Adapter (Part of 49 T088 0A0)</p>		<p>For inspection of tachometer</p>	<p>49 T088 008A</p> <p>Instruction Manual</p>	 <p>For inspection of tachometer</p>

STRUCTURAL VIEW

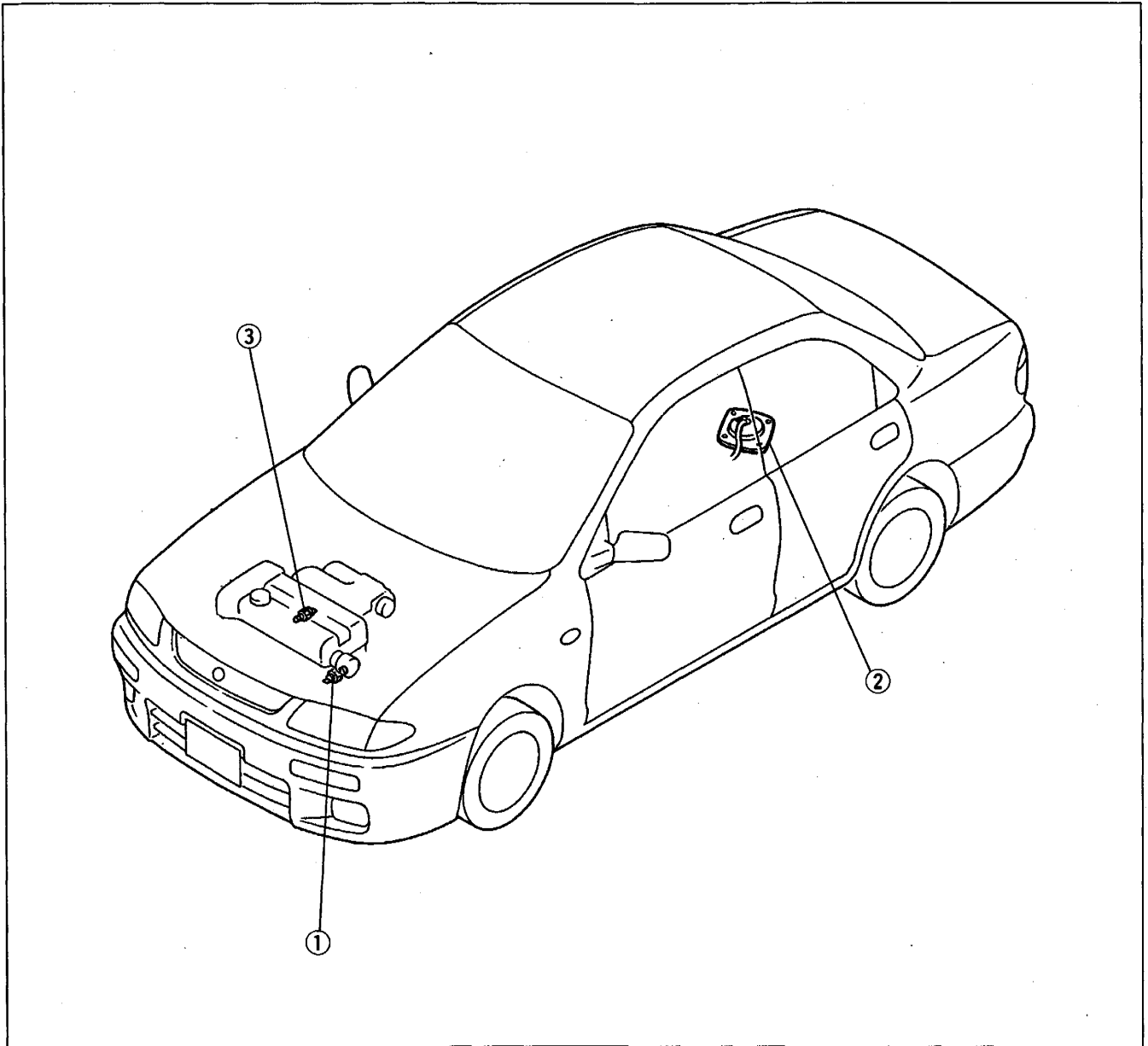

- 1. Water temperature sender unit
 - Removal / Installation page T1-55
 - Inspection page T1-56
- 2. Fuel gauge sender unit
 - Inspection page T1-56

- 3. Oil pressure switch
 - Inspection page T1-58

WITH TACHOMETER

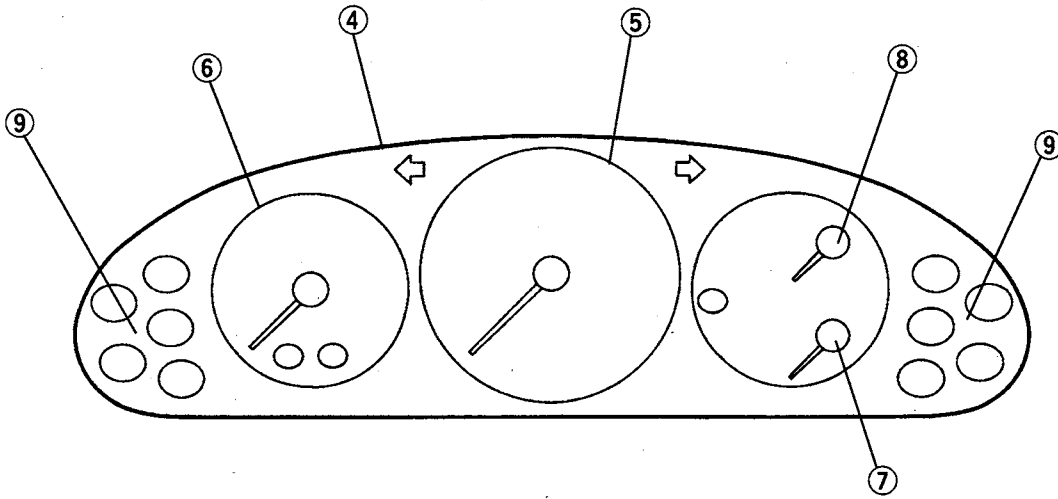

WITHOUT TACHOMETER

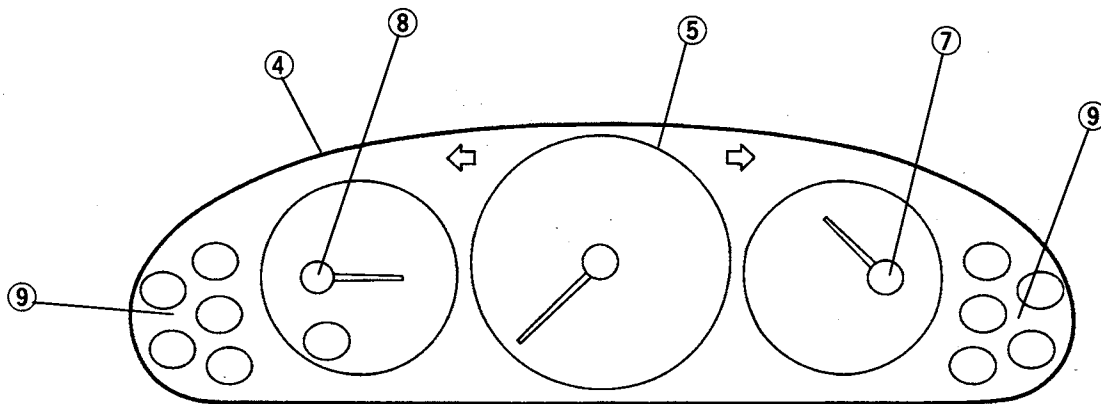

4. Instrument cluster

Removal / Installation page T1-51

Disassembly / Assembly page T1-52

5. Speedometer

Inspection page T1-54

6. Tachometer

Inspection page T1-54

7. Fuel gauge

Inspection page T1-55

8. Water temperature gauge

Inspection page T1-54

9. Warning and indicator light

Structural view page T1-57

Bulb replacement page T1-58

INSTRUMENT CLUSTER

Removal / Installation

1. Remove the meter hood.
(Refer to section S1.)
2. Remove in the order shown in the figure.
3. Install in the reverse order of removal.

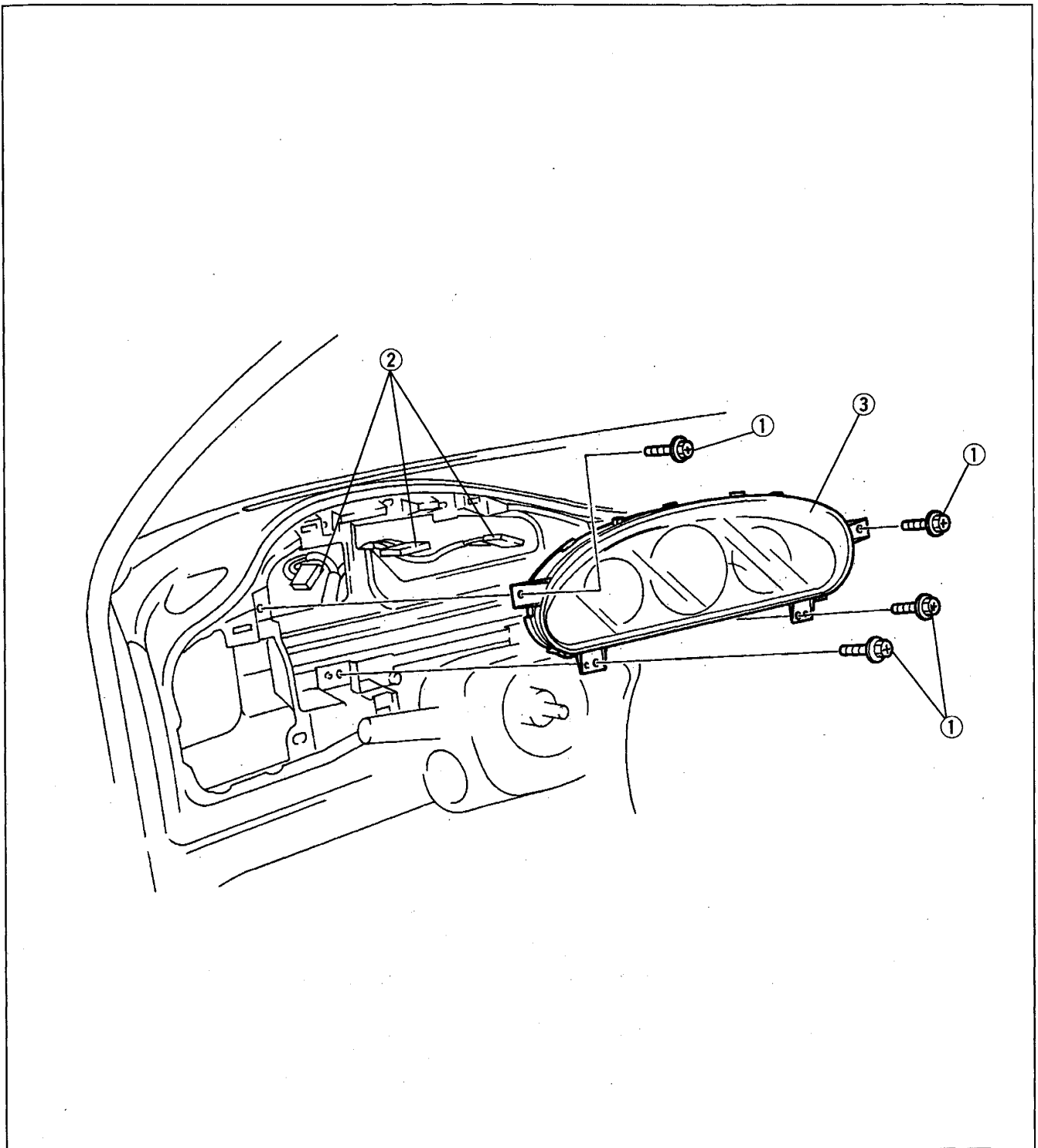

1. Screws
2. Connectors

3. Instrument cluster
Disassembly / Assembly page T1-52

Disassembly / Assembly

1. Disassemble in the order shown in the figure.
2. Assemble in the reverse order of disassembly.

WITH TACHOMETER

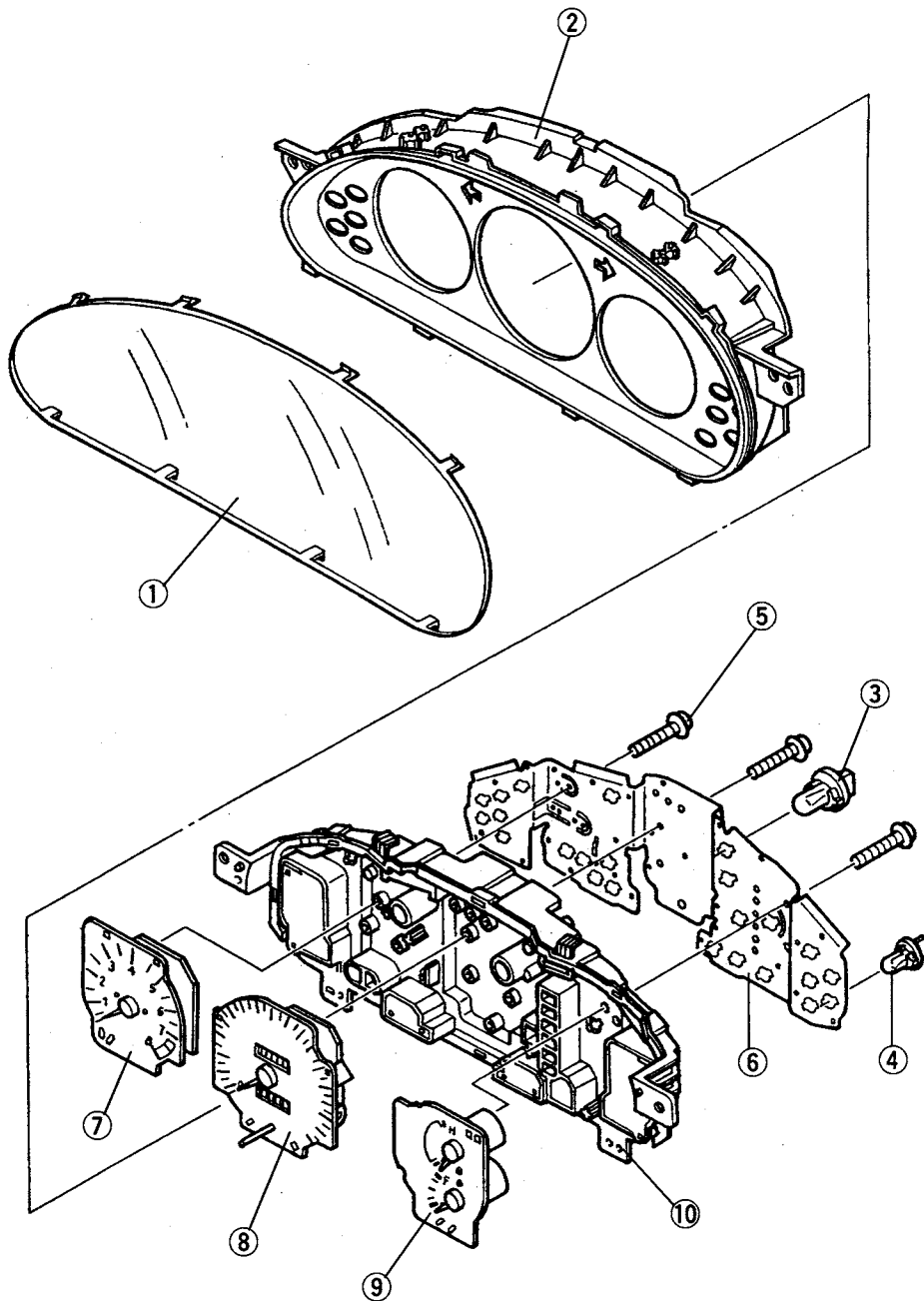

- | | |
|-----------------|--------------------------------------|
| 1. Glass front | 6. Print plate |
| 2. Window plate | 7. Tachometer |
| 3. Socket | 8. Speedometer |
| 4. Bulb | 9. Fuel and water temperature gauges |
| 5. Screw | 10. Case |

WITHOUT TACHOMETER

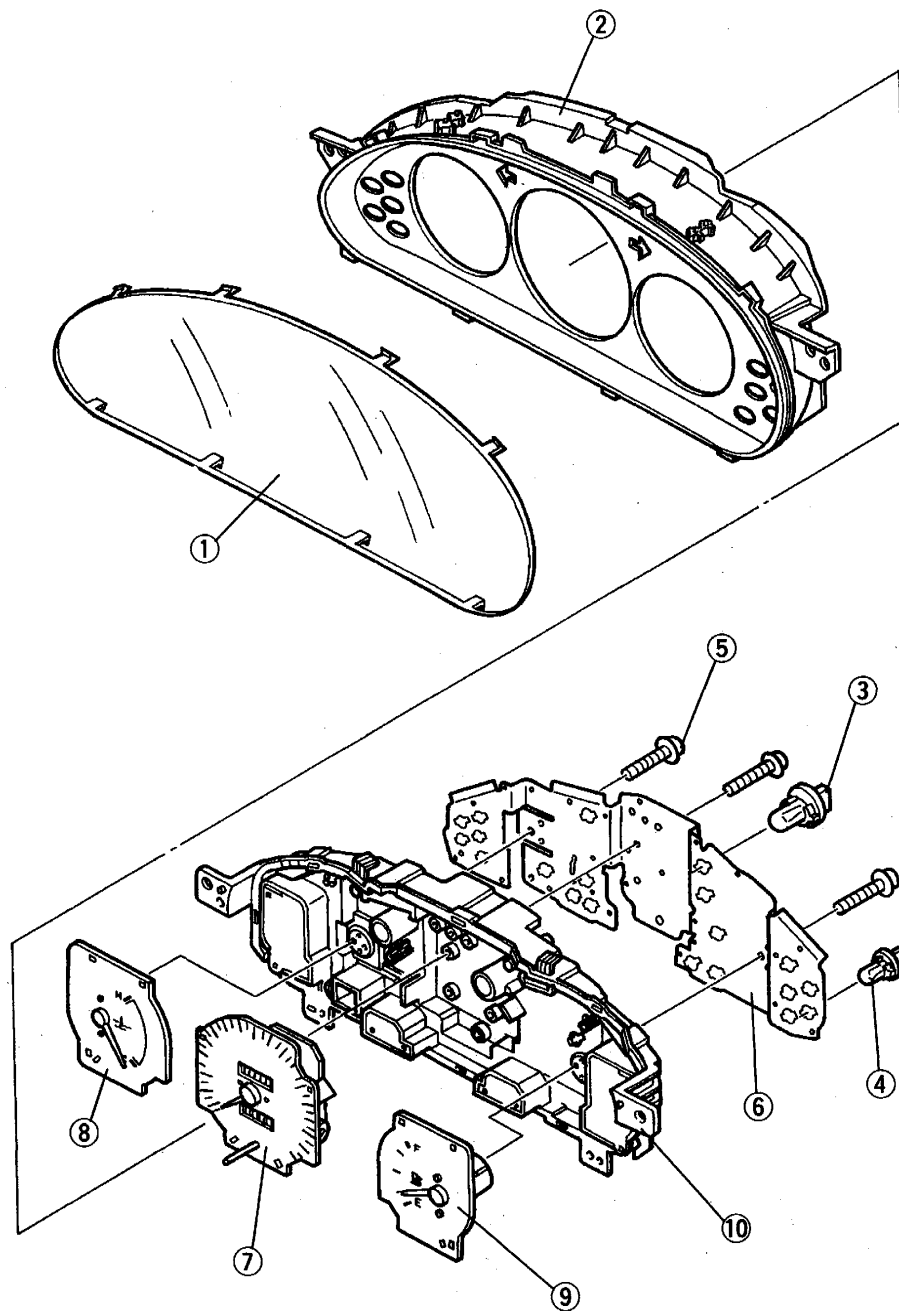

- 1. Glass front
- 2. Window plate
- 3. Socket
- 4. Bulb
- 5. Screw

- 6. Print plate
- 7. Speedometer
- 8. Water temperature gauge
- 9. Fuel gauge
- 10. Case

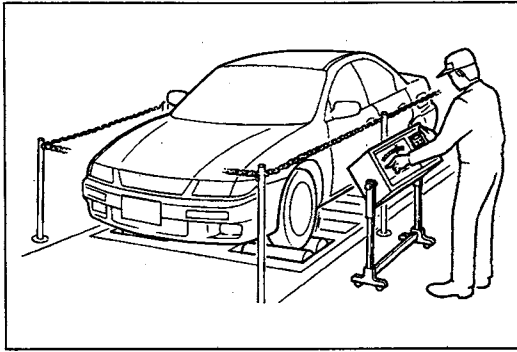

SPEEDOMETER

Inspection

1. Move the vehicle onto a speedometer tester.
2. Raise the vehicle speed and verify that the speedometer needle corresponds to the tester needle.
3. If the speedometer does not operate or the indication error is excessive, inspect the vehicle speedometer sensor and wiring harness.
4. If the vehicle speedometer sensor and wiring harness are OK, replace the speedometer.
(Refer to pages T1-51, 52.)

Vehicle speed (km/h)	Meter indication (km/h)
40	36.0—46.0
90	81.0—103.5

Vehicle speed (MPH)	Meter indication (MPH)
30	27.0—34.5
80	72.0—92.0

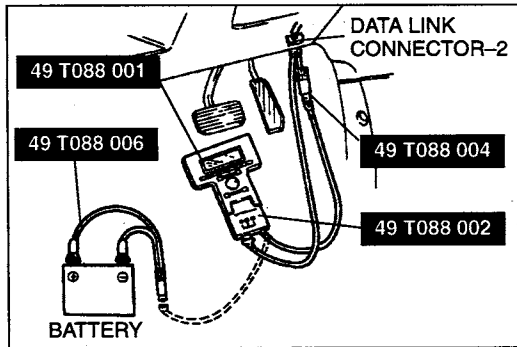

TACHOMETER

Inspection

1. Connect the **SST** (NGS) to the data link connector-2 and battery.
2. Referring to the NGS operational manual, select the PID DATA MONITOR function.
3. Using the PID DATA MONITOR function, measure the engine speed.
4. Compare the values of the vehicle tachometer and the **SST** (NGS).

Engine speed (rpm)	Meter indication (rpm)
650	552.5—708.5
6,000	5,820—6,540

5. If not as specified, inspect the wiring harness.
(distributor — instrument cluster)
6. If the wiring harness is normal, replace the tachometer.
(Refer to pages T1-51, 52.)

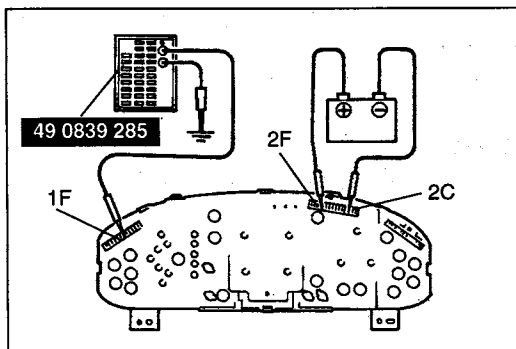

WATER TEMPERATURE GAUGE

Inspection

1. Remove the instrument cluster.
(Refer to page T1-51.)
2. Connect battery positive voltage to terminal 2F and ground to terminal 2C of the instrument cluster.
3. Connect the positive (+) lead of the **SST** to terminal 1F of the instrument cluster and the negative (-) lead to ground.

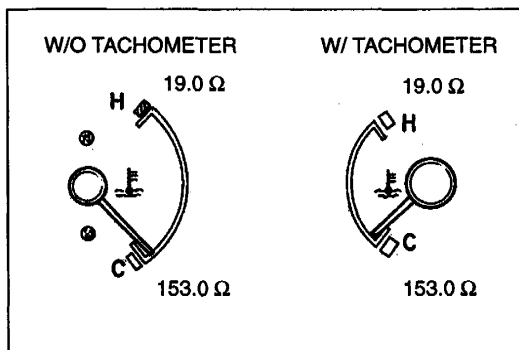

4. Verify that the water temperature gauge indicates the values shown in the figure.
5. If not as specified, replace the water temperature gauge.

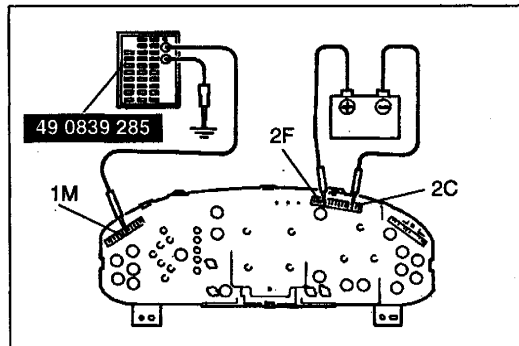

FUEL GAUGE

Inspection

1. Remove the instrument cluster.
(Refer to page T1-51.)
2. Connect battery positive voltage to terminal 2F and ground to terminal 2C of the instrument cluster.
3. Connect the positive (+) lead of the **SST** to terminal 1M of the instrument cluster and the negative (-) lead to ground.

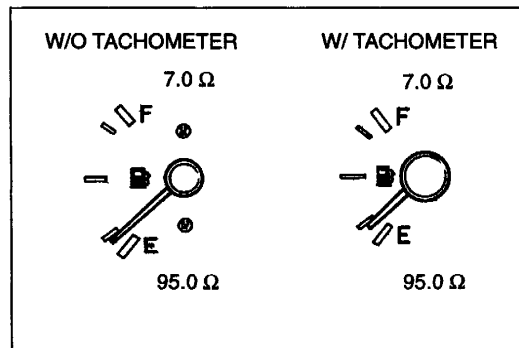

4. Verify that the fuel gauge indicates the values shown in the figure.
5. If not as specified, replace the fuel gauge.

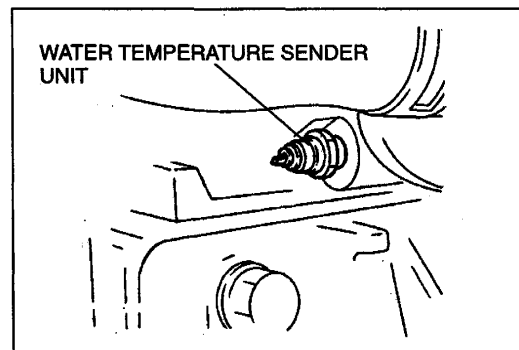

WATER TEMPERATURE SENDER UNIT

Removal / Installation

1. Disconnect the water temperature sender unit connector.
2. Remove the water temperature sender unit.

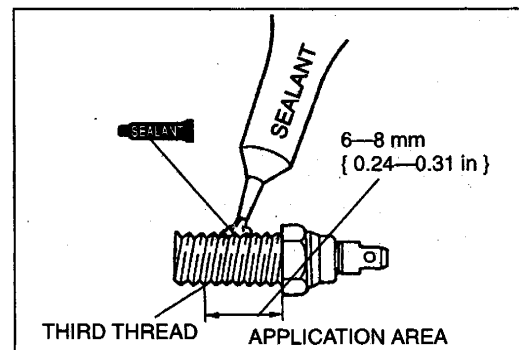

3. Before installing the unit, apply sealant from the third thread to the top thread.
4. Install in the reverse order of removal.

Tightening torque:

6.4-9.3 N·m { 65-95 kgf·cm , 57-82 in-lbf }

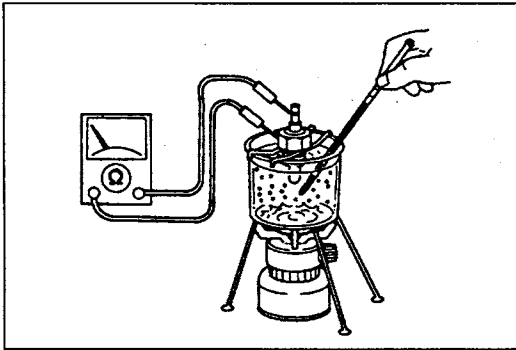

Inspection

1. Remove the water temperature sender unit.
2. Place the sender unit in a container of water.
3. Heat the water gradually, and measure the resistance of the sender unit.

Temperature	°C { °F }	50 { 122 }
Resistance	Ω	192.4—259.6

4. If not as specified, replace the water temperature sender unit.

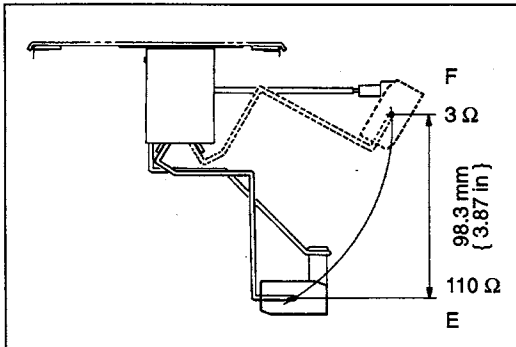

FUEL GAUGE SENDER UNIT

Inspection

1. Remove the fuel gauge sender unit.
(Refer to sections F1 and F2.)
2. Connect an ohmmeter between the terminals of the sender unit.
3. Measure the resistance while slowly moving the unit arm from point E to point F.
4. If not as specified, replace the fuel gauge sender unit.

WARNING AND INDICATOR LIGHT
Structural View

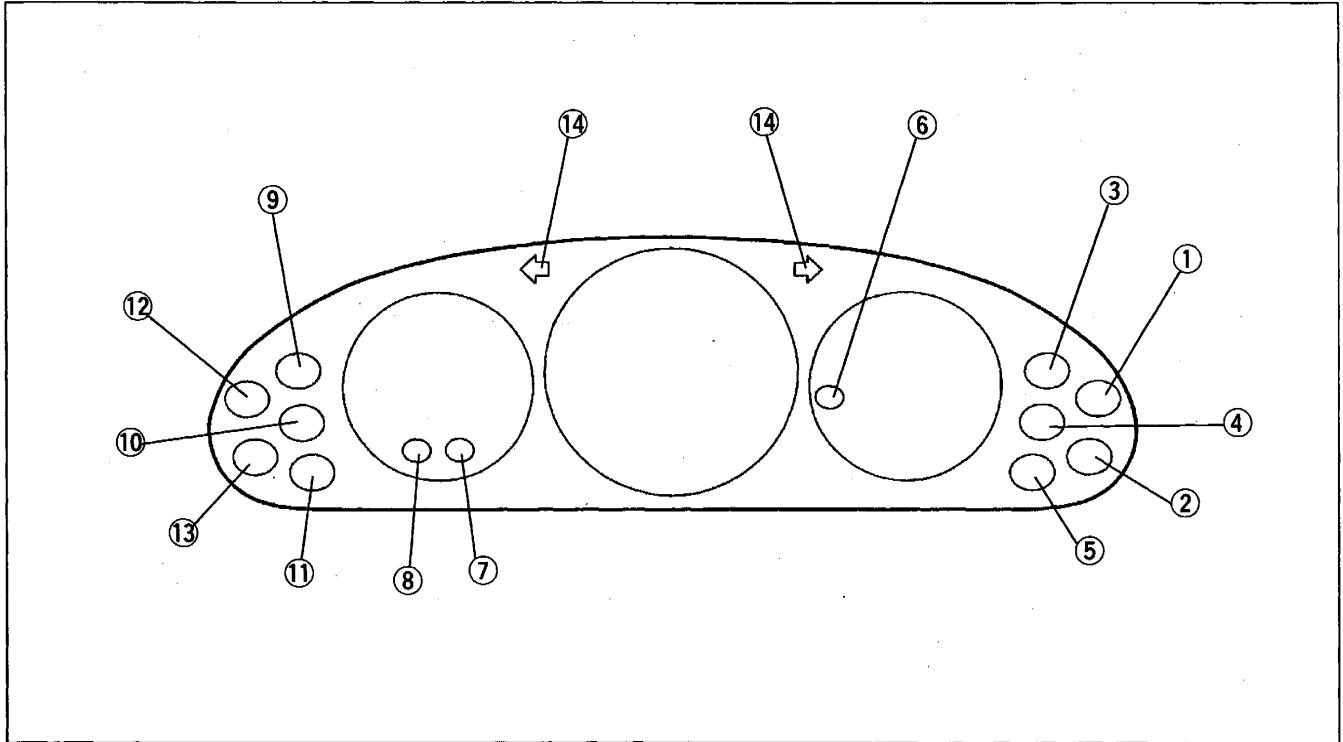

		Bulb	Specification
1	Rear window defroster indicator light	Without tachometer	1.4 W
2	ABS warning light		1.4 W
3	Rear window defroster indicator light	With tachometer	1.4 W
	Cruise set indicator light	Without tachometer	1.4 W
4	Door ajar warning light	With tachometer	1.4 W or 3.4 W
	High beam indicator light	Without tachometer	3.4 W
5	Oil pressure warning light		1.4 W
6	HOLD indicator light	With tachometer	1.4 W
7	High beam indicator light	With tachometer	3.4 W
8	Generator warning light	With tachometer	1.4 W
	HOLD indicator light	Without tachometer	1.4 W
9	Cruise set indicator light	With tachometer	1.4 W
	Air bag system warning light	Without tachometer	1.4 W
10	Air bag system warning light	With tachometer	1.4 W
	Generator warning light	Without tachometer	1.4 W
11	Brake system warning light		1.4 W
12	MIL		1.4 W
13	Seat belt warning light		1.4 W
14	Turn signal indicator light		3.4 W × 2
—	Instrument cluster illumination		3.4 W × 3 1.4 W × 2

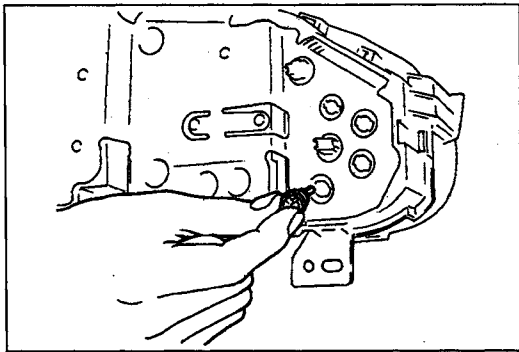

Bulb Replacement

1. Remove the instrument cluster.
(Refer to page T1-51.)
2. Replace the bulb as shown in the figure.

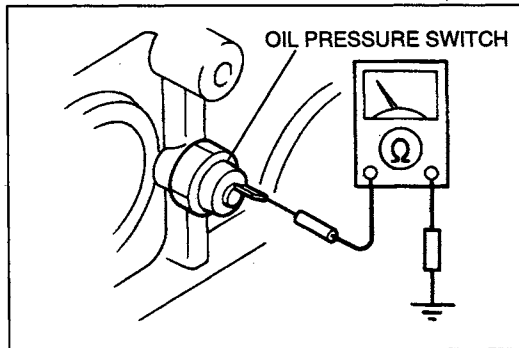

OIL PRESSURE SWITCH

Inspection

1. Disconnect the oil pressure switch connector.
2. Check for continuity between the terminals of the oil pressure switch and ground.

Engine condition	Continuity
Running	No
Stopped	Yes

3. If not as specified, measure the oil pressure.
(Refer to section D.)
4. If the oil pressure is normal, replace the oil pressure switch.
(Refer to section D.)

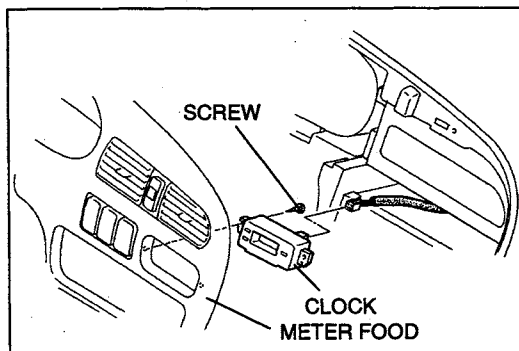

CLOCK

Removal / Installation

1. Remove the meter hood.
(Refer to section S1.)
2. Remove the screws and the clock.
3. Install in the reverse order of removal.

HORN

STRUCTURAL VIEW

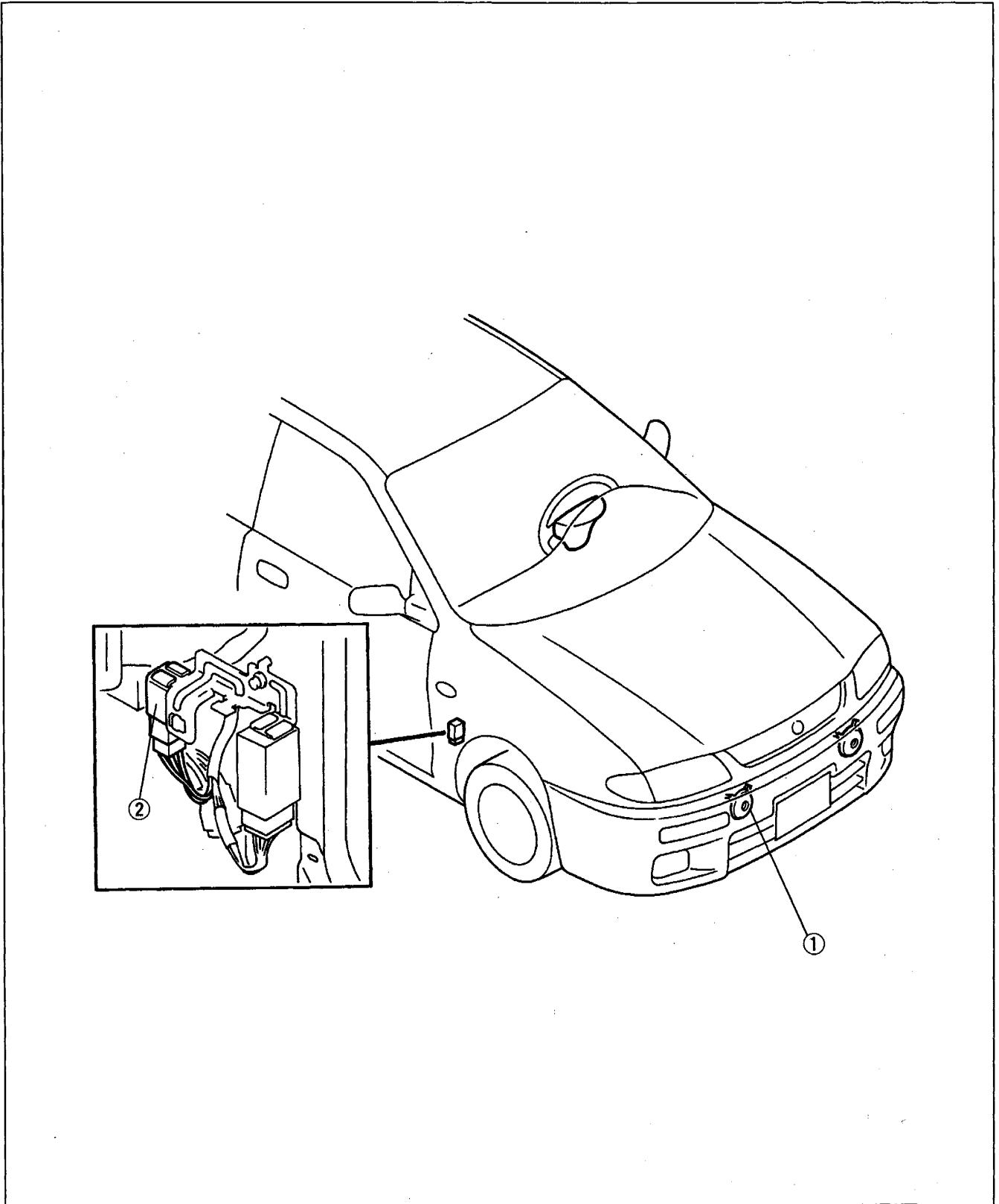

1. Horn
Removal / Installation page T1-60
On-vehicle inspection page T1-60

2. Horn relay
Removal / Installation page T1-60
Inspection page T1-60

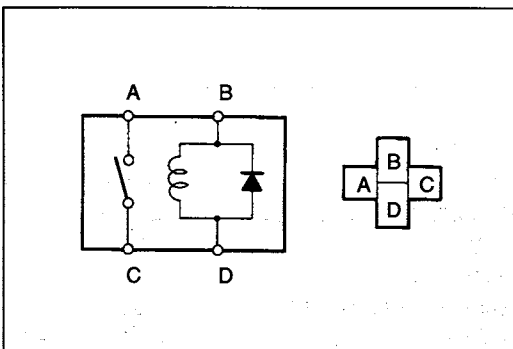
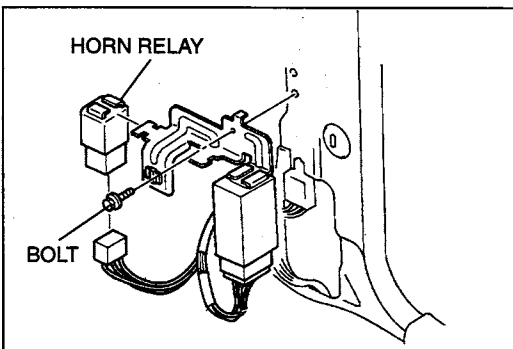
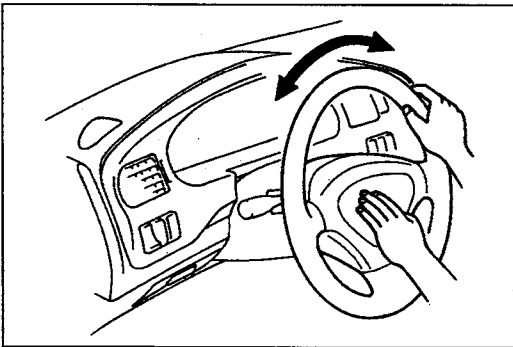
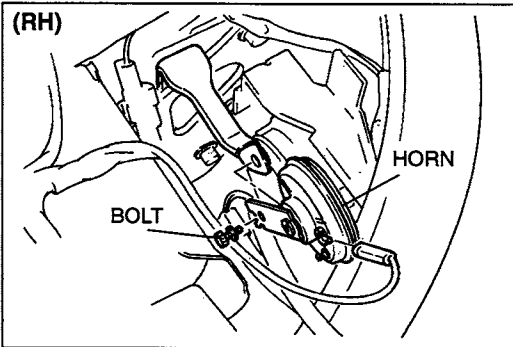
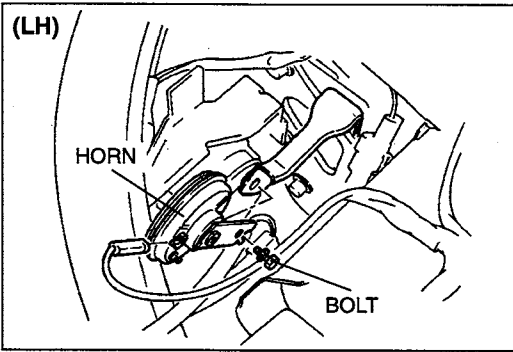

HORN

Removal / Installation

1. Remove the headlight.
(Refer to page T1-12.)
2. Disconnect the horn connector.
3. Remove the bolt and the horn.
4. Install in the reverse order of removal.

On-vehicle Inspection

While turning the steering wheel, verify that horn sounds when the horn switch is pressed.

HORN RELAY

Removal / Installation

1. Remove the scuff plate and front side trim.
(Refer to section S1.)
2. Disconnect the horn relay connector
3. Remove the bolt and the bracket.
4. Remove the horn relay.
5. Install in the reverse order of removal.

Inspection

1. Apply battery positive voltage and check for continuity between the relay terminals.

○—○: Continuity B+: Battery positive voltage

Step	Terminal	D	B	A	C
1		○—○	○—○		
2		GND	B+	○—○	○—○

2. If not as specified, replace the horn relay.

AUDIO

PREPARATION

SST

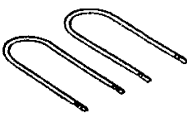
<p>49 UN01 050</p> <p>Radio removing tool</p> 	<p>For removal of audio unit</p>
---	----------------------------------

STRUCTURAL VIEW

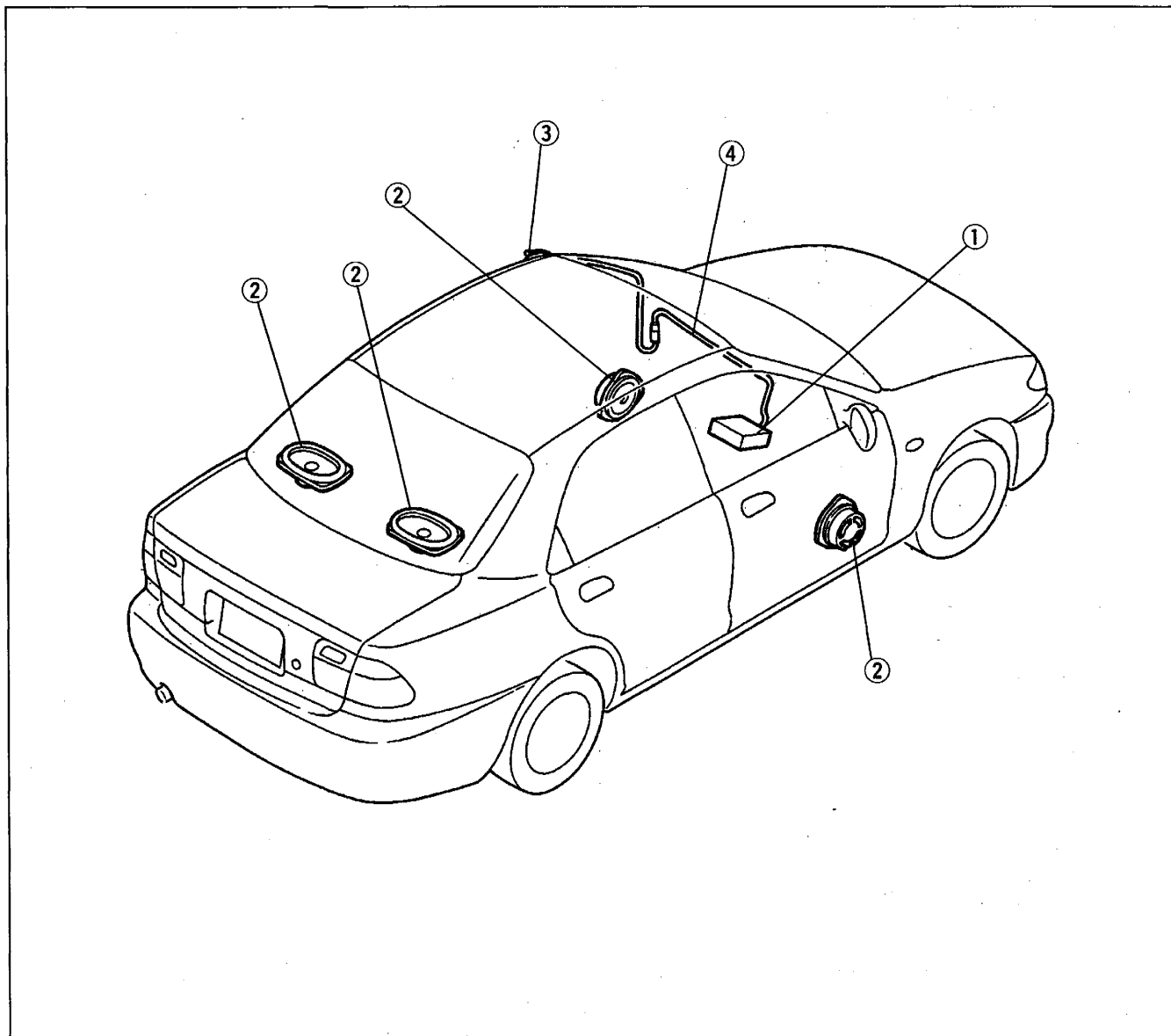

1. Audio unit		3. Roof antenna	
Removal	page T1-62	Removal	page T1-64
Installation	page T1-62	Installation	page T1-64
2. Speaker		Inspection	page T1-65
Removal / Installation	page T1-63	4. Antenna feeder	
Inspection	page T1-64	Removal / Installation	page T1-65
		Inspection	page T1-66

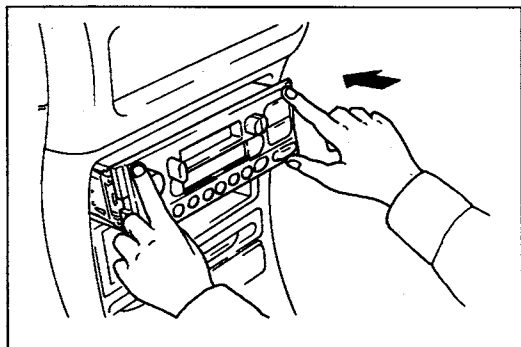
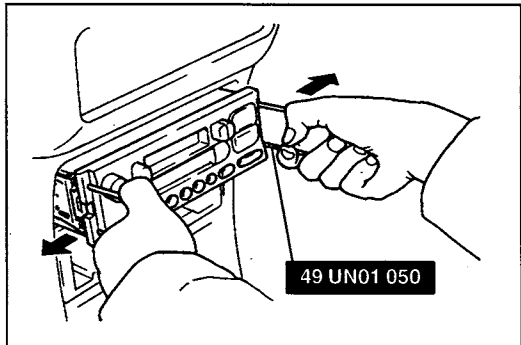
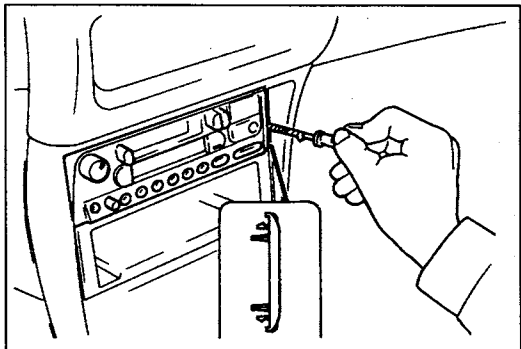
**AUDIO UNIT****Removal**

1. Pry out the audio unit service hole covers by using a flat-head screwdriver which has been wrapped in tape. Keep the hole covers for reinstallation.
2. With the beveled parts of the **SST** facing inward, insert them into the audio unit.
3. Pull the **SST** outward and rearward to slide out the audio unit.
4. Disconnect the connector and antenna jack.

Installation

1. Install the audio unit service hole covers.
2. Connect the audio unit connector and antenna jack.
3. Insert the audio unit until each clip clicks. Verify that the wiring harness and antenna feeder are not caught between the audio unit and the dashboard.

SPEAKER**Removal / Installation****Door speaker**

1. Remove the front door trim.
(Refer to section S1.)
2. Remove in the order shown in the figure.
3. Install in the reverse order of removal.

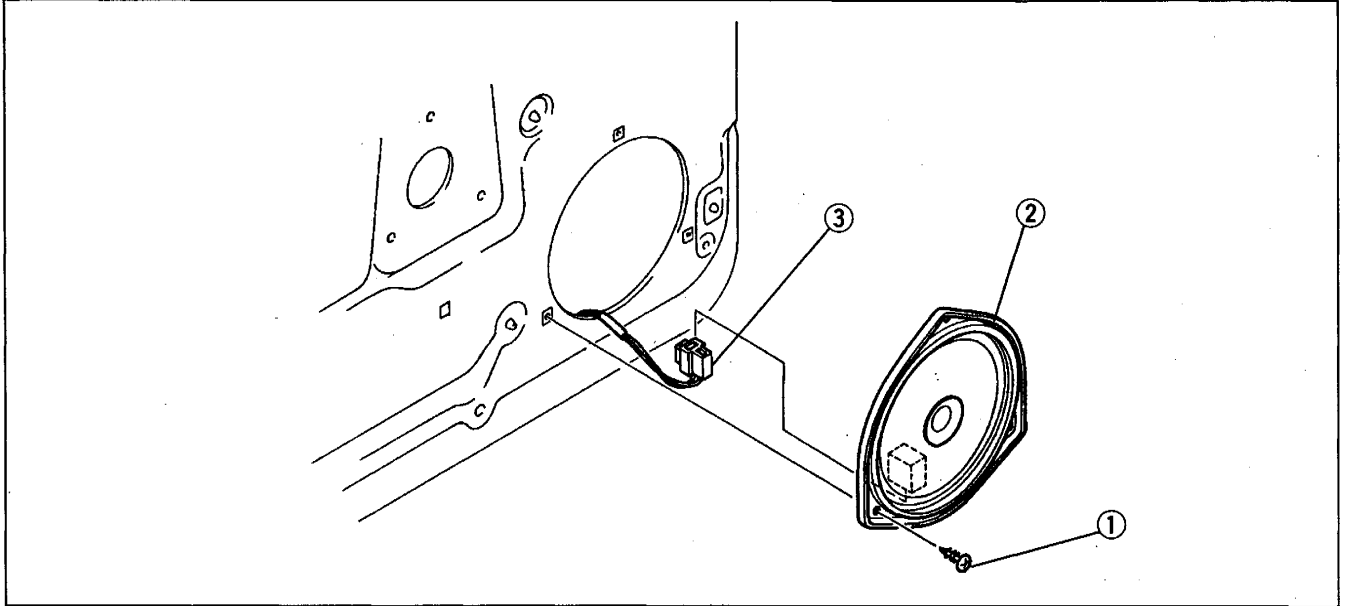

1. Screw
2. Door speaker

3. Door speaker connector

Rear speaker

1. Remove the rear package trim.
(Refer to section S1.)
2. Remove in the order shown in the figure.
3. Install in the reverse order of removal.

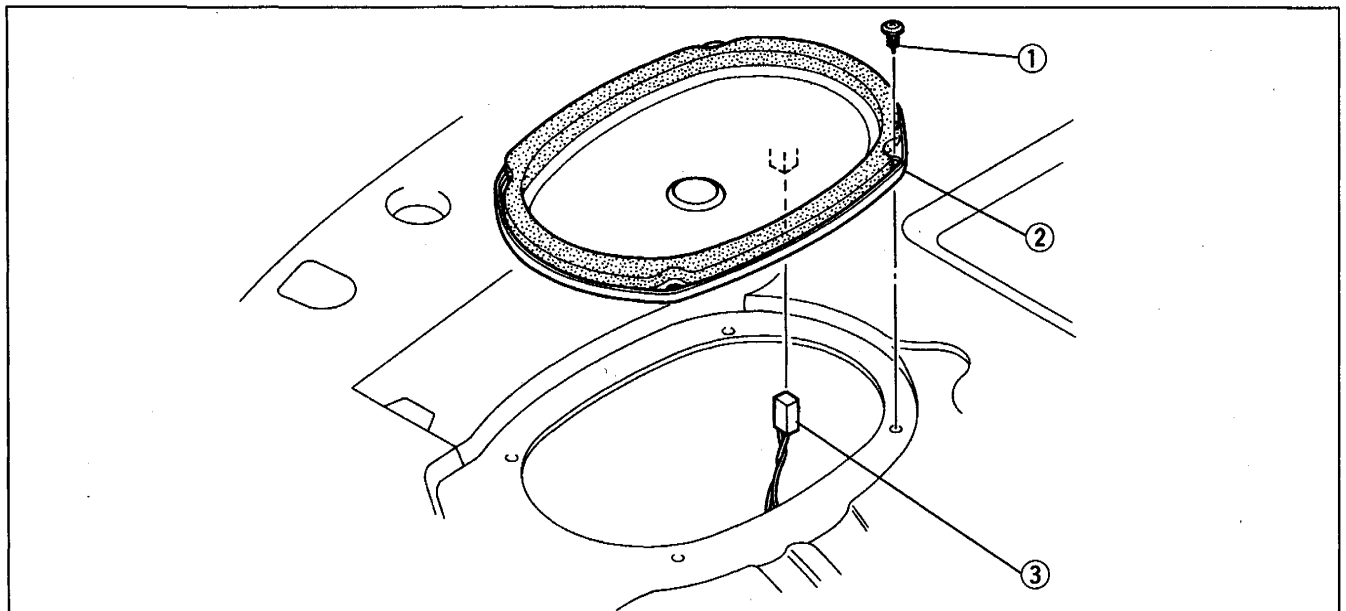

1. Screw
2. Rear speaker

3. Rear speaker connector

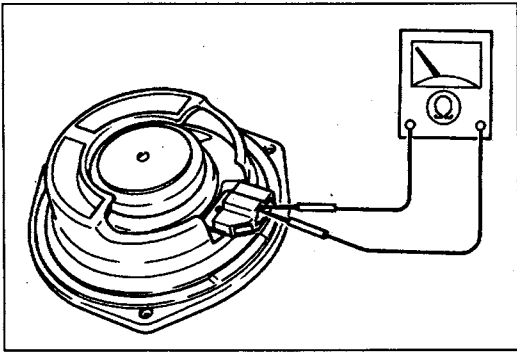

Inspection

1. Remove the speaker. (Refer to page T1-63.)
2. Measure the resistance between the terminals of the speaker.

Resistance: 4 Ω

3. Touch the leads of an ohmmeter to the speaker terminals and verify that the speaker clicks.
4. If not as specified, replace the speaker.

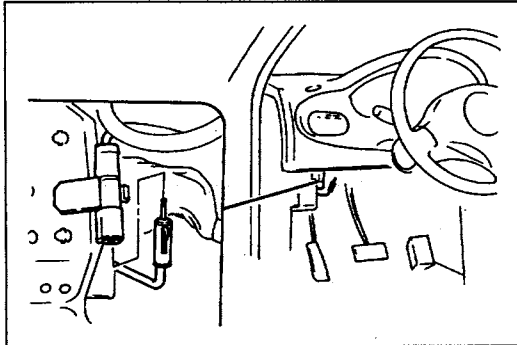

ROOF ANTENNA

Removal

1. Remove the lower panel.
(Refer to section S1.)
2. Disconnect the antenna jack.

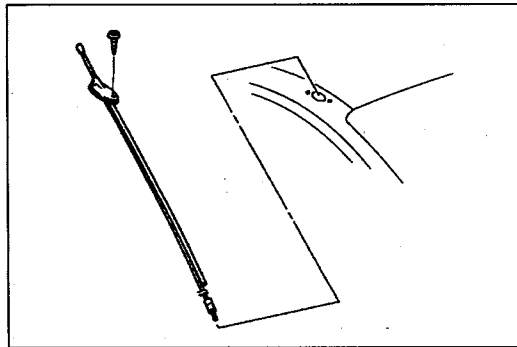

3. Remove the screw and pull out the roof antenna.

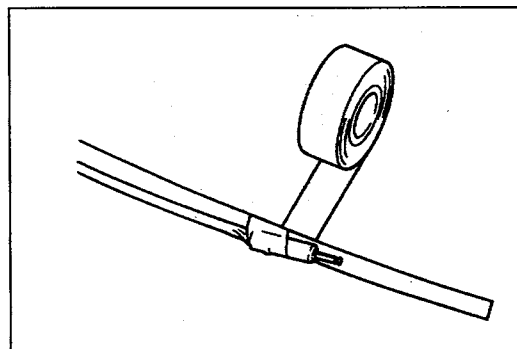

Installation

1. Tape the antenna jack to the drain pipe.

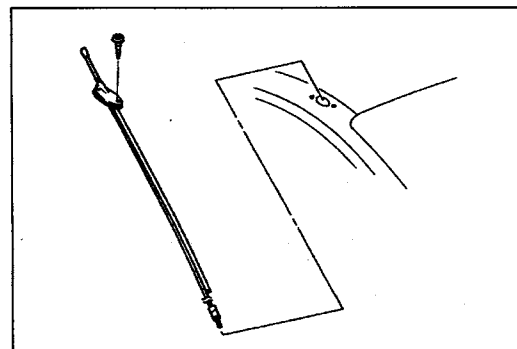

2. Pass the antenna feeder and drain pipe through the A-pillar from the hole in the roof.
3. Connect the antenna feeder and install the roof antenna.

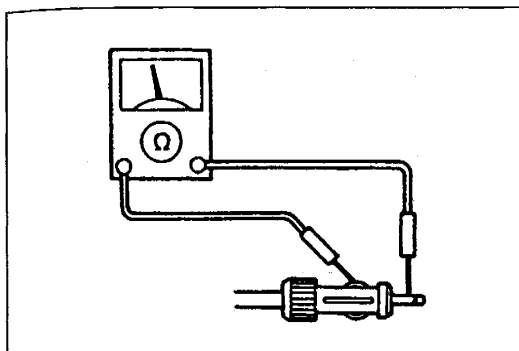
**Inspection**

1. Remove the lower panel.
(Refer to section S1.)
2. Disconnect the antenna jack.
3. Check the antenna by using an ohmmeter.

Resistance: Infinite

4. If not as specified, replace the roof antenna.
(Refer to page T1-64.)

ANTENNA FEEDER**Removal / Installation**

1. Remove the dashboard.
(Refer to section S1.)
2. Remove in the order shown in the figure.
3. Install in the reverse order of removal.

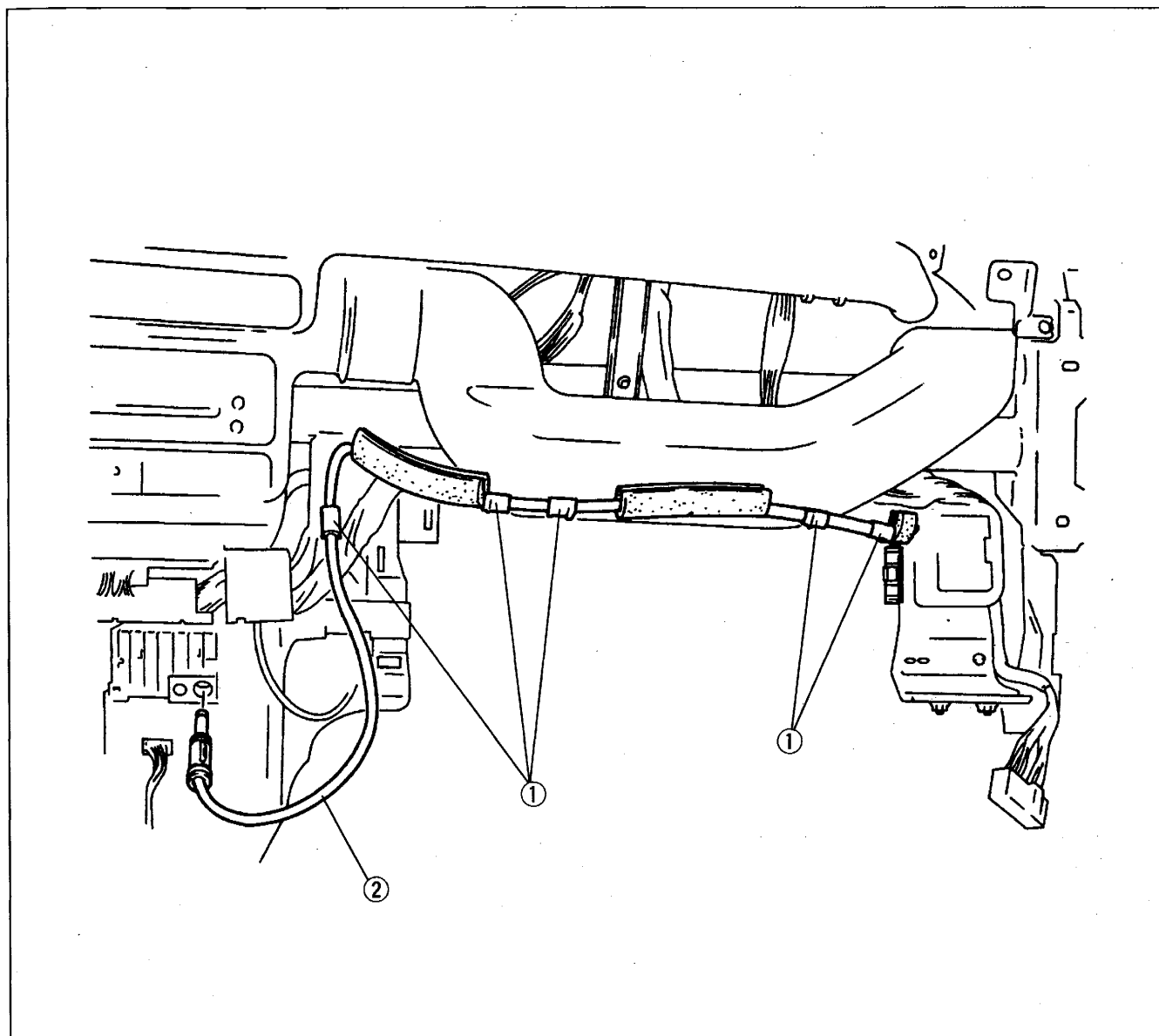

1. Clips

2. Antenna feeder

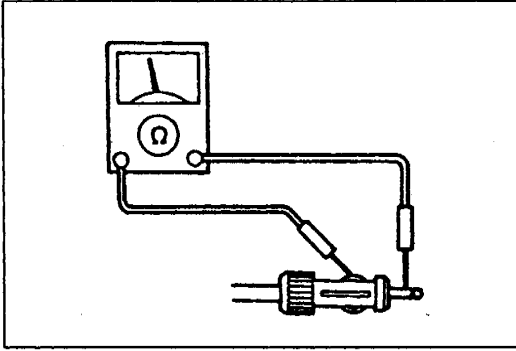
**Inspection**



1. Remove the audio unit.
(Refer to page T1-62.)
2. Disconnect the antenna jack.
3. Check the antenna by using an ohmmeter.

Resistance: Infinite

4. If not as specified, replace the antenna feeder.

CRUISE CONTROL SYSTEM

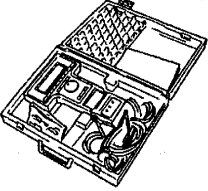
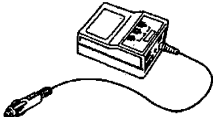
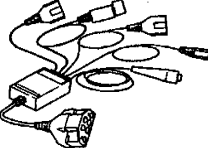
PREPARATION
SST

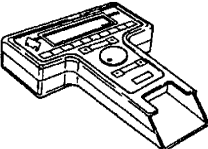
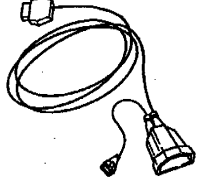
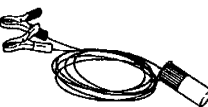
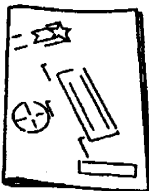
<p>49 T088 0A0 NGS set</p> 	<p>For diagnosis of cruise control system</p>	<p>49 T088 002 Vehicle Interface Module (Part of 49 T088 0A0)</p> 	<p>For diagnosis of cruise control system</p>
<p>49 T088 003 Super MECS Adapter (Part of 49 T088 0A0)</p> 	<p>For diagnosis of cruise control system</p>	<p>49 T088 010B Program Card</p> 	<p>For diagnosis of cruise control system</p>
<p>49 T088 001 Control Unit (Part of 49 T088 0A0)</p> 	<p>For diagnosis of cruise control system</p>	<p>49 T088 005 STAR/DCL Adapter (5 pin) (Part of 49 T088 0A0)</p> 	<p>For diagnosis of cruise control system</p>
<p>49 T088 006 Battery Hookup Adapter (Part of 49 T088 0A0)</p> 	<p>For diagnosis of cruise control system</p>	<p>49 T088 008A Instruction Manual</p> 	<p>For diagnosis of cruise control system</p>

STRUCTURAL VIEW

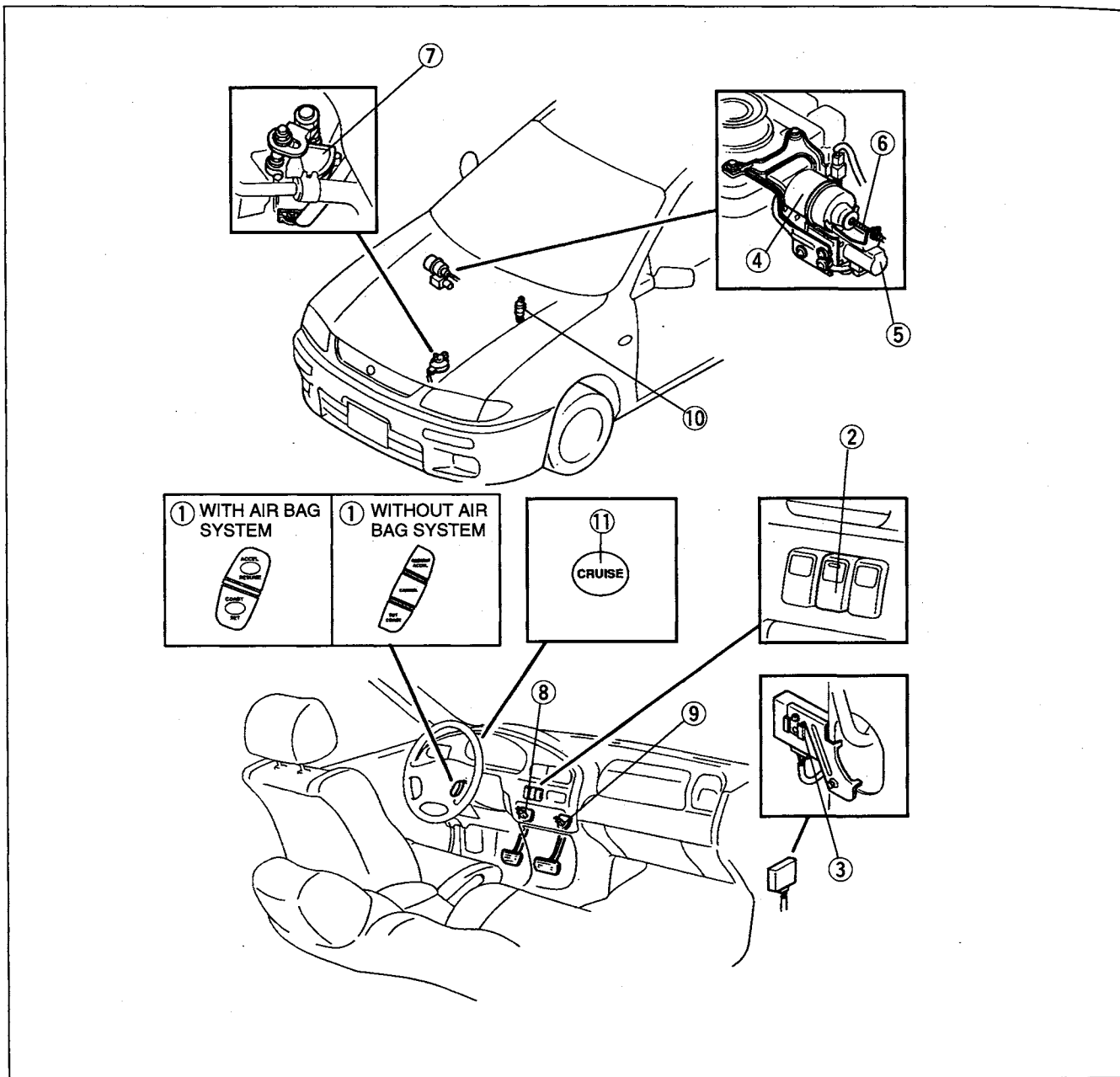

- | | |
|--|----------------------|
| 1. Cruise control switch | |
| Removal / Installation | page T1-94 |
| Inspection | page T1-95 |
| 2. Cruise control main switch | |
| Removal / Installation | page T1-96 |
| Inspection | page T1-96 |
| 3. Cruise control module | |
| Removal / Installation | page T1-89 |
| Inspection | page T1-90 |
| 4. Cruise actuator | |
| Removal / Installation | page T1-91 |
| Inspection | page T1-92 |
| 5. Vacuum pump | |
| Removal / Installation | page T1-92 |
| Inspection | page T1-93 |
| 6. Actuator cable | |
| Removal / Installation | page T1-93 |
| Adjustment | page T1-93 |
| 7. Transaxle range switch | |
| Removal / Installation | section K |
| Inspection | section K |
| 8. Clutch switch | |
| Removal / Installation | section F1, F2 |
| Inspection | section F1, F2 |
| 9. Brake switch | |
| Removal / Installation | section P |
| Inspection | section P |
| 10. Vehicle speedometer sensor | |
| Removal / Installation | section K |
| Inspection | section K |
| 11. Cruise set indicator light (in instrument cluster) | |

ON-BOARD DIAGNOSTIC**Outline**

- There are two on-board diagnostic functions: Condition Detection Mode, which indicates troubles in the system; and Operation Mode, which checks for and indicates correct operation of the input signals to the control module.
- The two functions can be done by using either of the following methods:
 - 1) Checking the output of the data link connector by using the **SST** (NGS set)
 - 2) Checking the flashing pattern of the cruise set indicator light

Operation Order

Use Condition Detection Mode or Operation Mode or both to inspect the cruise control system. Either diagnostic function can be done before the other. If one diagnostic function does not locate the trouble, carry out the other function.

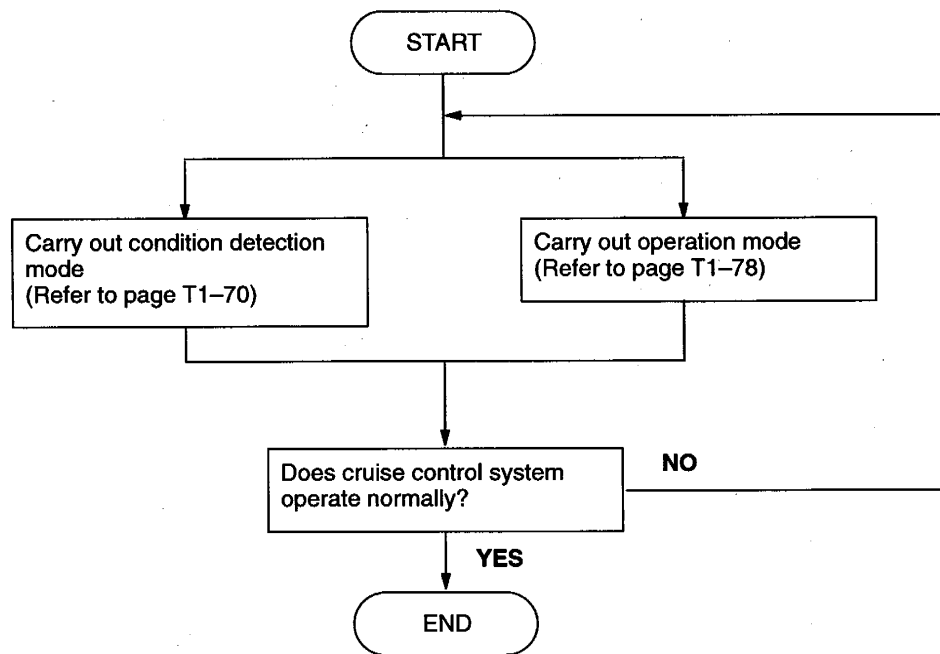

Condition Detection Mode Using NGS

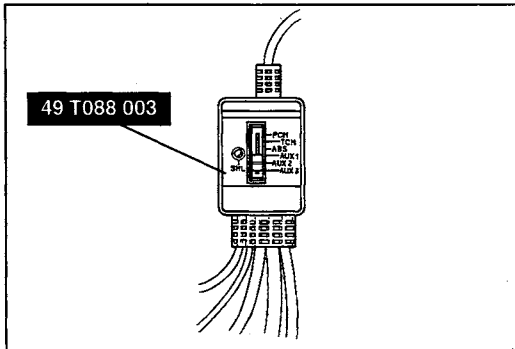
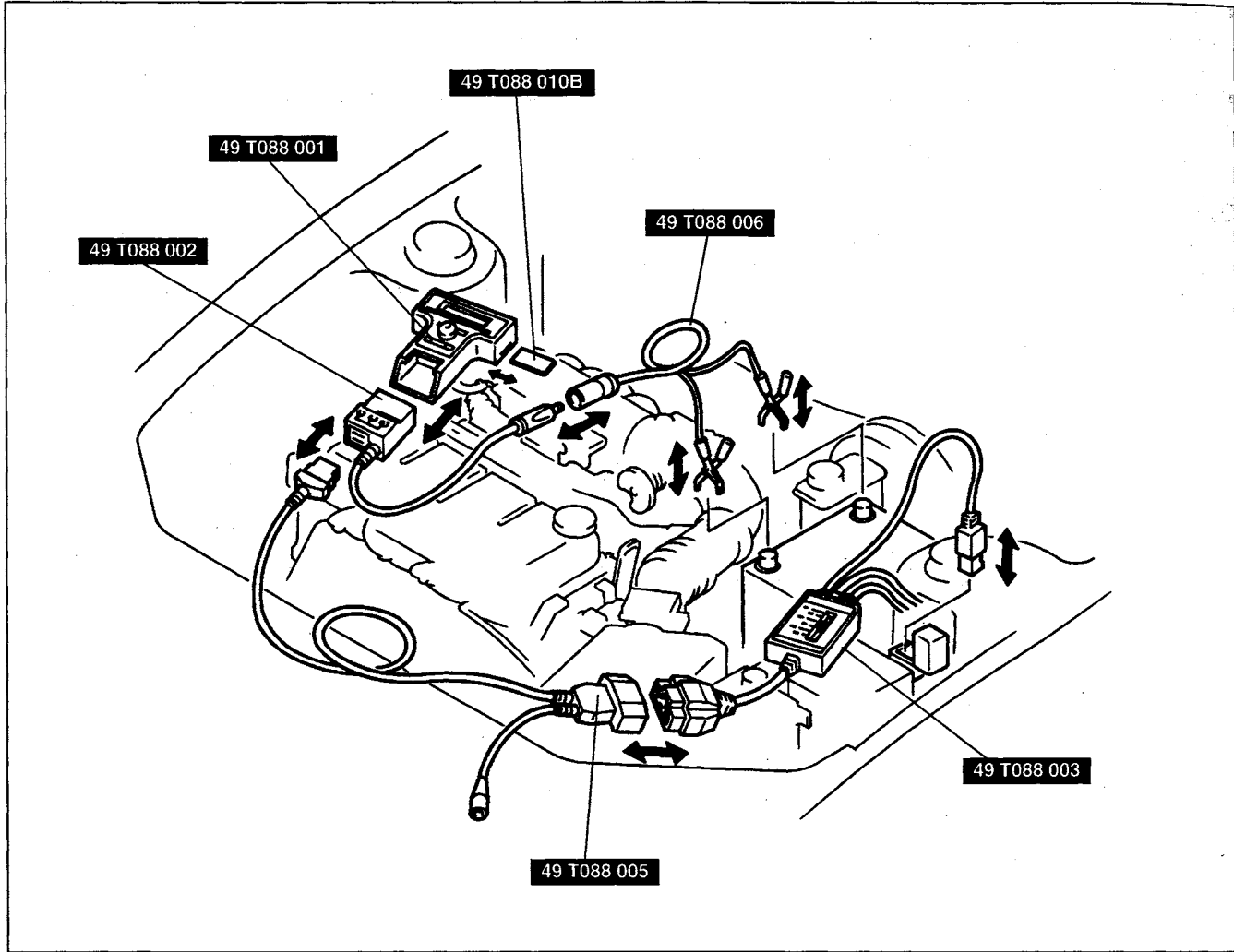

1. Position the vehicle on a chassis roller.
2. Connect the **SST** (NGS) to the data link connector and battery.
3. Set the **SST** (Super MECS Adapter) to AUX 2.

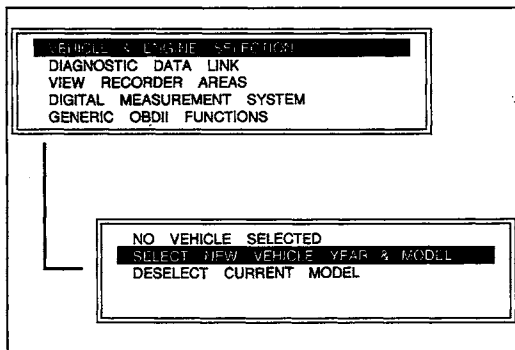

4. Select "VEHICLE & ENGINE SELECTION" on the **SST** (Control Unit) display, and then select the vehicle model, engine type, and model year.

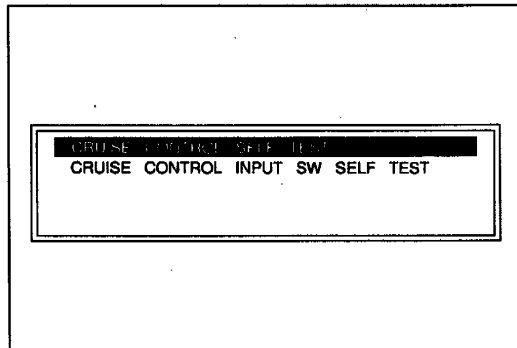
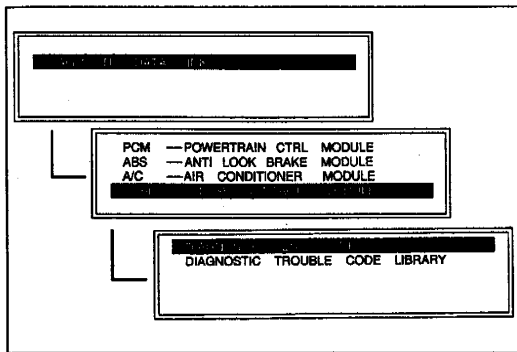

5. Select "DIAGNOSTIC DATA LINK" on the **SST** (Control Unit) display.
6. Select "CCM-CRUISE CONTROL MODULE" on the **SST** (Control Unit) display, and then select the "DIAGNOSTIC TEST MODE".
7. Increase the vehicle speed over 16 km/h { 10 MPH }.
8. Select "CRUISE CONTROL SELF TEST" on the **SST** (Control Unit) display.
9. (1) If a diagnostic trouble code is displayed, refer to the diagnostic trouble code table (Refer to page T1-72) and inspect the appropriate system area.
 (2) If "NO CODES RECEIVED" is displayed, the system areas shown in the diagnostic trouble code table are OK. Inspect another system area.
10. After the problems are corrected, repeat the condition detection mode procedure to verify that the system is operating normally.

Cancel

To cancel condition detection mode, do any one of the following:

- Turn the cruise control main switch off.
- Turn the ignition switch to LOCK.

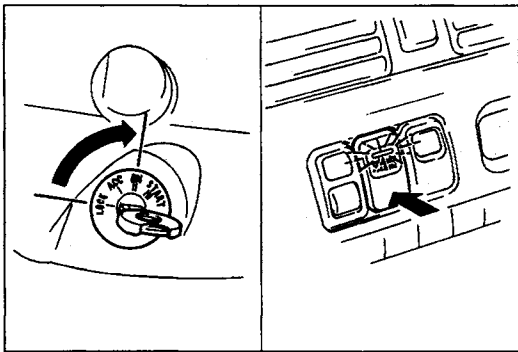

Using cruise set indicator light Reference

- If the RESUME/ACCEL switch on the cruise control switch is malfunctioning, the cruise set indicator light will not give a correct indication when you inspect the system. Use the **SST** (NGS set) to determine the cause of the malfunction. (Refer to page T1-70.)

Inspection

1. Turn the ignition switch to ON.
2. Turn the cruise control main switch on.
3. Press and hold the RESUME/ACCEL switch for at least 3 seconds to activate the on-board diagnostic. The cruise set indicator light will illuminate for 3 seconds and then go out for at least 2 seconds.
4. If a problem is present, the cruise set indicator light will flash in one of the patterns shown below. If there is no problem in the system, the light will not flash.

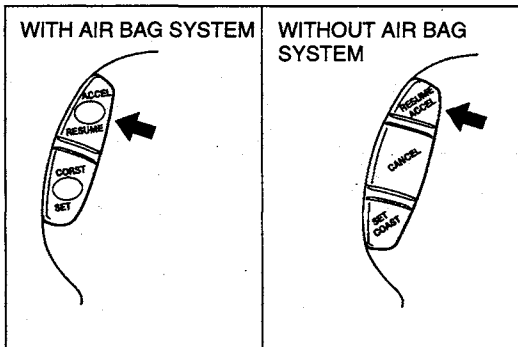

Cancel

To cancel condition detection mode, do any one of the following:

- Turn the cruise control main switch off.
- Turn the ignition switch to LOCK.
- Drive the vehicle at over 16 km/h { 10 MPH }.

Diagnostic trouble code table

If there are two or more problems in the cruise control system, the problem with the highest priority will be indicated.

Priority	DTC	Display on the NGS	Possible cause	Inspection area	Refer to page
1	1	ACTUATOR — CIRCUIT MALFUNCTION	<ul style="list-style-type: none"> • Vacuum pump • Cruise control module • Defective wiring harness 	<ul style="list-style-type: none"> • Vacuum pump connector • Vacuum pump • Wiring harness (Cruise control module — Vacuum pump) 	T1-73
2	5	STOP FUSE — CIRCUIT MALFUNCTION	<ul style="list-style-type: none"> • Burnt STOP 15 A fuse • Brake switch • Defective wiring harness 	<ul style="list-style-type: none"> • STOP 15 A fuse • Brake switch connector • Brake switch • Wiring harness (STOP 15 A fuse — Brake switch — Cruise control module) 	T1-75
3	7	BRAKE SW — DEFECT	<ul style="list-style-type: none"> • Brake switches are on simultaneously 	Brake switch	T1-76
4	11	SET/COAST SW — DEFECT (ALWAYS ON)	<ul style="list-style-type: none"> • Cruise control switch 	Cruise control switch (SET/COAST switch)	T1-77
5	12	RESUME/ACCEL SW — DEFECT (ALWAYS ON)	<ul style="list-style-type: none"> • Cruise control switch 	Cruise control switch (RESUME/ACCEL switch)	T1-77
6	15	CRUISE CONTROL MODULE — DEFECT	<ul style="list-style-type: none"> • Cruise control module 	—	T1-77

Troubleshooting

Flowchart No.1	Symptom	Diagnostic trouble code 1
----------------	---------	---------------------------

Possible cause

- Damaged cruise control module
- Damaged vacuum pump
- Open or short circuit in wiring harness
- Poor connection of connector

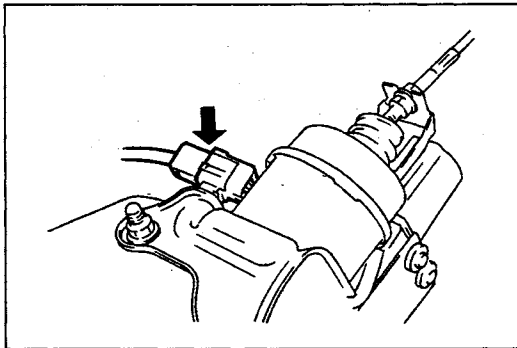

Step 1

Make sure the vacuum pump connector is securely connected to the vacuum pump.

Connection	Action
OK	Go to Step 2
Poor	Reconnect connector

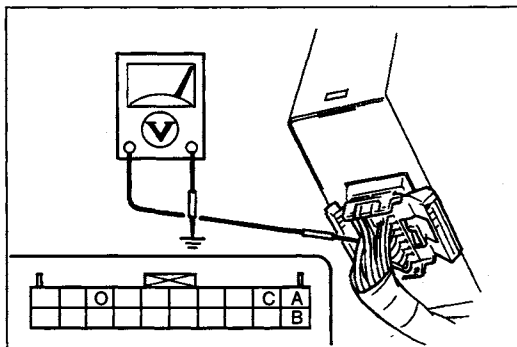

Step 2

1. Pull out the cruise control module with the cruise control module connector connected.
(Refer to page T1-89.)
2. Turn the ignition switch to ON.
3. Turn the cruise control main switch on.
4. Measure the voltage at the terminals of the cruise control module connector.

Terminal	Voltage	Action
A (G/L)	About 9 V	Measure voltage at terminals O
B (G/B)	Other	Go to Step 3
C (G/Y)		
O (P)	About 9 V	Go to Step 5
	Other	Replace cruise control module (Refer to page T1-89)

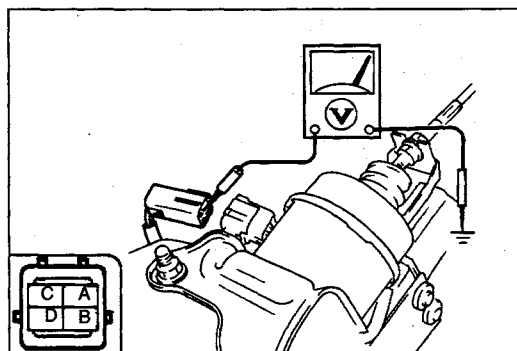

Step 3

1. Turn the ignition switch to LOCK.
2. Disconnect the vacuum pump connector.
3. Turn the ignition switch to ON.
4. Turn the cruise control main switch on.
5. Measure the voltage at terminal A (P) of the vacuum pump connector.

Voltage	Action
About 9 V	Go to Step 4
Other	Go to Step 5

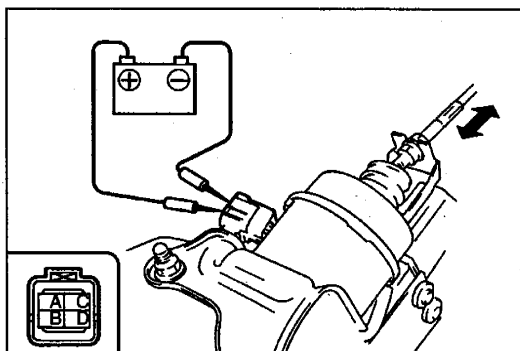
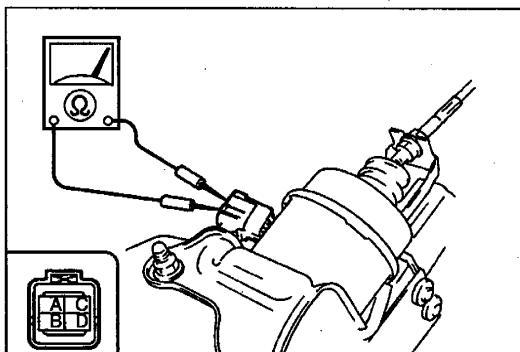

Step 4

1. Measure the resistance between the vacuum pump terminals.

Terminals	Resistance (Ω)
A—C	55
A—B	
A—D	6
B—C	110
B—D	60
C—D	

2. Connect battery positive voltage and verify the operation of the actuator cable as indicated below.

B+: Battery positive voltage

Step	Terminal connection				Actuator cable operation
	A	B	C	D	
1	GND	B+	B+	B+	Pull
2	GND	B+	B+	—	Hold
3	GND	B+	—	—	Extend
4	—	—	—	—	Release

3. If correct, repair the wiring harness (cruise control module — vacuum pump).
4. If not as specified, replace the vacuum pump. (Refer to page T1-92.)

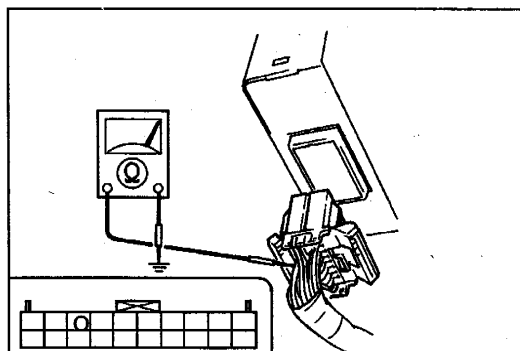

Step 5

1. Turn the ignition switch to LOCK.
2. Disconnect the cruise control module connector.
3. Connect terminal A (P) of the vacuum pump connector to ground.
4. Check for continuity between terminal O (P) of the cruise control module connector and ground.

Continuity	Action
Yes	Replace cruise control module (Refer to page T1-89)
No	Repair wiring harness (Cruise control module — Vacuum pump)

Flowchart No.2	Symptom	Diagnostic trouble code 5
-----------------------	----------------	---------------------------

Possible cause

- Burnt STOP 15 A fuse
- Damaged brake switch
- Open or short circuit in wiring harness
- Poor connection of connector

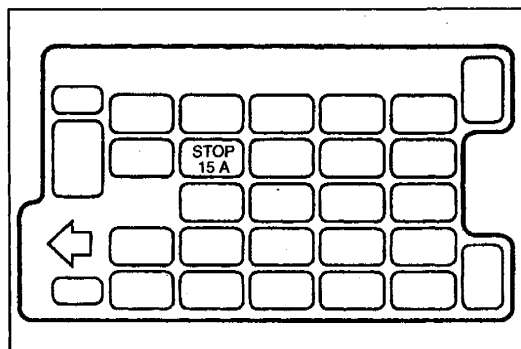

Step 1

Check the STOP 15 A fuse in the fuse block.

Fuse	Action
OK	Go to Step 2
Burnt	Replace fuse after checking and repairing wiring harness

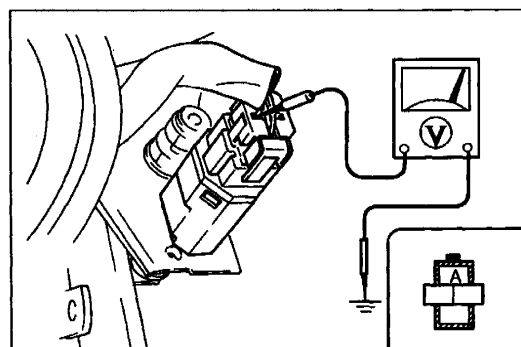

Step 2

Measure the voltage at terminal A of the brake switch connector.

B+: Battery positive voltage

Voltage	Action
B+	Go to Step 3
Other	Repair wiring harness (STOP 15 A fuse — Brake switch)

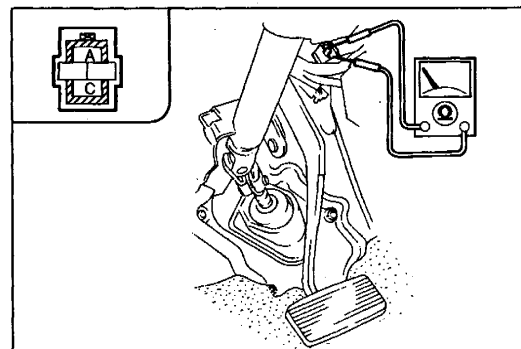

Step 3

1. Disconnect the brake switch connector.
2. Check for continuity between the switch terminals.

○—○: Continuity

Brake pedal	Terminal	
	A	C
Released		
Depressed	○—○	○—○

3. If not as specified, replace the brake switch. (Refer to section P.)

Flowchart No.3	Symptom	Diagnostic trouble code 7
----------------	---------	---------------------------

Possible cause

- Damaged cruise control module
- Damaged brake switch

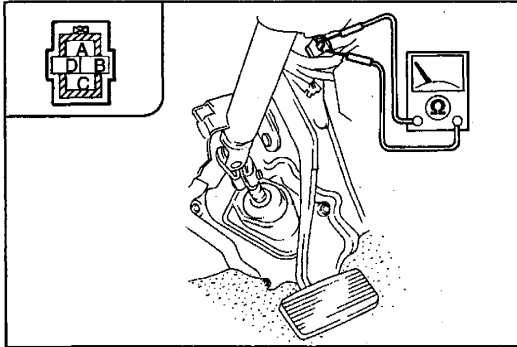

Remedy

1. Disconnect the brake switch connector.
2. Check for continuity between the switch terminals.

○—○: Continuity

Brake pedal	Terminal			
	A	C	B	D
Released			○—○	
Depressed	○—○			

3. If correct, replace the cruise control module.
(Refer to page T1-89.)
4. If not as specified, replace the brake switch.
(Refer to section P.)

Flowchart No.4	Symptom	Diagnostic trouble code 11 or 12
----------------	---------	----------------------------------

Possible cause

- Damaged cruise control module
- Damaged cruise control switch

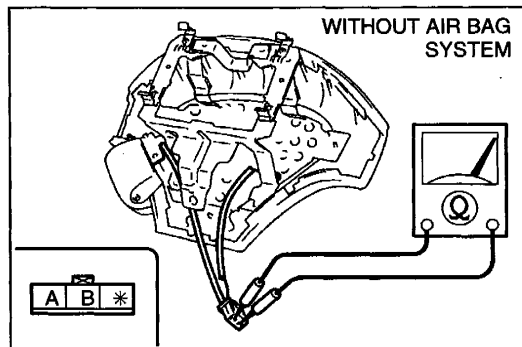
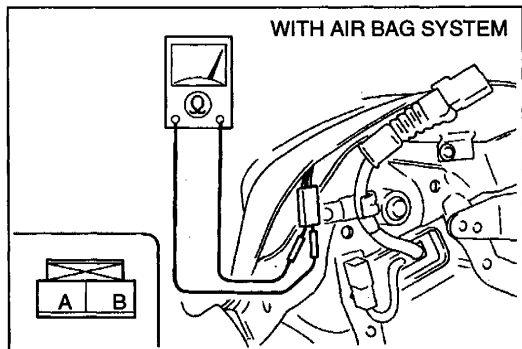

Remedy

Warning

- Handling the air bag module improperly can accidentally deploy the air bag, which may seriously injure you. Read **SERVICE WARNINGS**, page T1-98, before handling the air bag module.

1. Remove the driver-side air bag module. (Refer to page T1-107.)
(With air bag system)
Remove the horn pad.
(Without air bag system)
2. Disconnect the cruise control switch connector.
3. Measure the resistance between the switch terminals.

○—○ : Resistance ○—○ : Continuity

Switch position \ Terminal	A	B
SET/COAST	○—○	○—○ 240 Ω
RES/ACCEL	○—○	○—○ 910 Ω
CANCEL (without air bag system)	○—○	○—○

4. If correct, replace the cruise control module. (Refer to page T1-89.)
5. If not as specified, replace the cruise control switch. (Refer to page T1-94.)

Flowchart No.5	Symptom	Diagnostic trouble code 15
----------------	---------	----------------------------

Possible cause

- Damaged cruise control module

Remedy

Replace the cruise control module.
(Refer to page T1-89.)

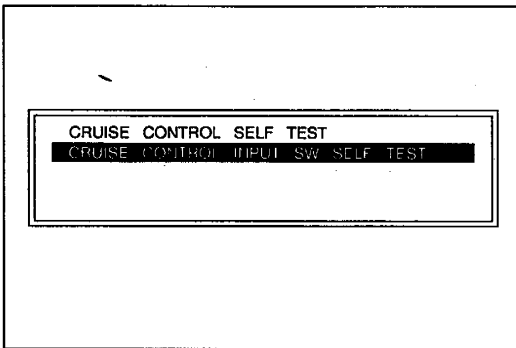

Operation Mode Using NGS

1. Carry out steps 1—6 of the condition detection mode procedure.
(Refer to page T1-70.)
2. Select "CRUISE CONTROL INPUT SW SELF TEST" on the **SST** (Control Unit) display.
3. Operate each switch as it is shown on the **SST** (Control Unit) display and note the diagnostic trouble code.
4. Refer to the diagnostic trouble code table on page T1-80. If the diagnostic trouble code shown in the table does not appear on the **SST** (Control Unit) display, inspect the corresponding system area.
5. After the problems are corrected, repeat the operation mode procedure to verify that the system is operating normally.

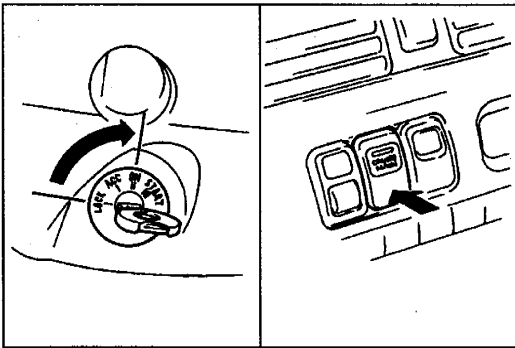

Inspection

1. Turn the ignition switch to ON.
2. Turn the cruise control main switch off.
3. Shift the transaxle to D or R range. (ATX)
Do not depress the clutch pedal. (MTX)
4. Press the RESUME/ACCEL switch and the cruise control main switch simultaneously to activate system inspection.
5. Operate each switch as described and note the diagnostic trouble code pattern. If the correct diagnostic trouble code pattern is not indicated, inspect the corresponding system area.

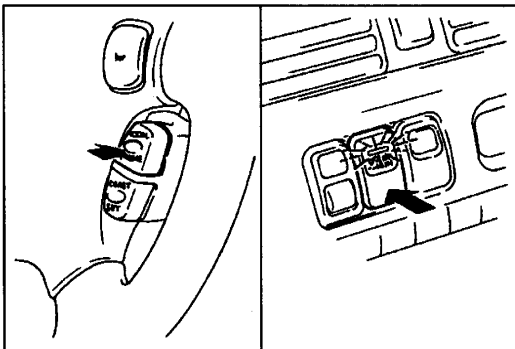

Cancel

To cancel operation mode, do any one of the following:

- Turn the cruise control main switch off.
- Turn the ignition switch to LOCK.

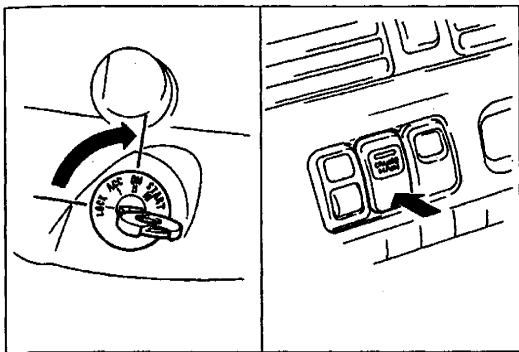
**Using cruise set indicator light****Inspection**

1. Turn the ignition switch to ON.
2. Turn the cruise control main switch off.
3. Shift the transaxle to D or R range. (ATX)
Do not depress the clutch pedal. (MTX)

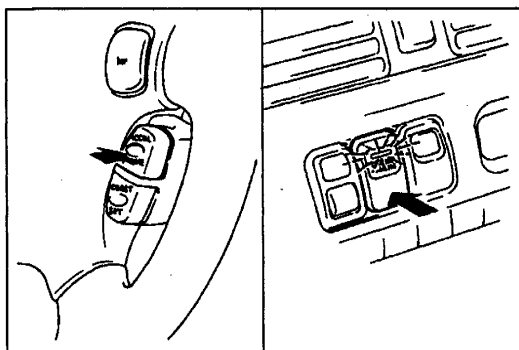

4. Press the RESUME/ACCEL switch and the cruise control main switch simultaneously to activate system inspection. (The cruise set indicator light will illuminate.)
5. Operate each switch as described and note the diagnostic trouble code pattern. If the cruise set indicator light does not flash, inspect the corresponding system area.

Cancel

To cancel operation mode, do any one of the following:

- Turn the cruise control main switch off.
- Turn the ignition switch to LOCK.

Diagnostic trouble code table

The table below shows the code numbers and flash patterns that will be indicated if the system is operating correctly.

Procedure	DTC	Display on the NGS	Possible cause	Inspection area	Refer to page
Press SET/COAST switch	21	SET/COAST SW — PRESS	<ul style="list-style-type: none"> • Cruise control switch (SET/COAST) • Cruise control module 	<ul style="list-style-type: none"> • Cruise control switch connector • Cruise control switch 	T1-81
Press RESUME/ACCEL switch	22	RESUME/ACCEL SW — PRESS	Cruise control module	Cruise control switch connector	T1-82
Depress brake pedal	31	BRAKE PEDAL — DEPRESS	<ul style="list-style-type: none"> • Burnt STOP 15 A fuse • Brake switch • Cruise control module • Defective wiring harness 	<ul style="list-style-type: none"> • STOP 15 A fuse • Brake switch • Wiring harness (STOP 15 A fuse — Brake switch and cruise control module, Cruise control module — Brake switch) 	T1-83
ATX Shift selector lever to P or N position	35	P OR N RANGE (NEUTRAL POSITION) — SHIFT	<ul style="list-style-type: none"> • Transaxle range switch • Cruise control module • Defective wiring harness 	<ul style="list-style-type: none"> • Transaxle range switch connector • Transaxle range switch • Wiring harness (Ignition switch — Transaxle range switch, Cruise control module — Transaxle range switch) 	T1-84
MTX Depress clutch pedal			<ul style="list-style-type: none"> • Clutch switch • Cruise control module • Defective wiring harness 	<ul style="list-style-type: none"> • Clutch switch connector • Clutch switch • Wiring harness (Ignition switch — Clutch switch, Ignition switch — Cruise control module — Clutch switch — GND) 	T1-86
Drive vehicle above 40 km/h { 25 MPH }	37	VEHICLE SPEED — ABOVE 40 km/h { 25 MPH }	<ul style="list-style-type: none"> • Instrument cluster • Vehicle speedometer sensor • Cruise control module • Defective wiring harness 	<ul style="list-style-type: none"> • Instrument cluster connector • Vehicle speedometer sensor connector • Vehicle speedometer sensor • Wiring harness (Instrument cluster — Vehicle speedometer sensor, Cruise control module — Instrument cluster) 	T1-87

Troubleshooting

Flowchart No.1	Symptom	Diagnostic trouble code 21 is not indicated
----------------	---------	---

Possible cause

- Damaged cruise control module
- Damaged cruise control switch
- Poor connection of connector

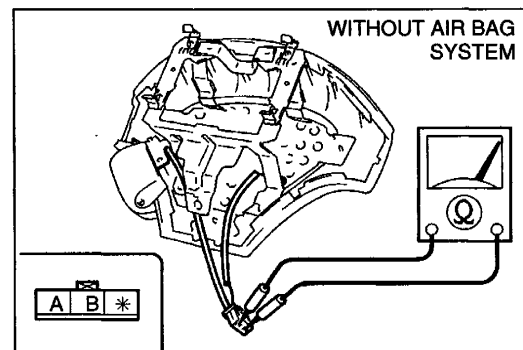
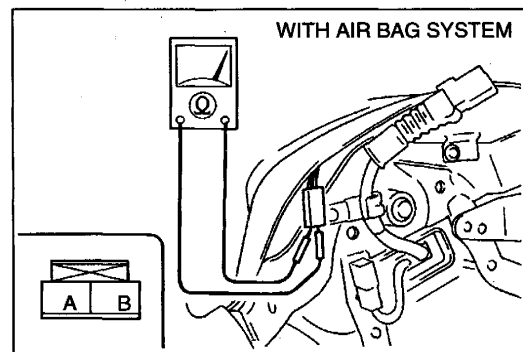
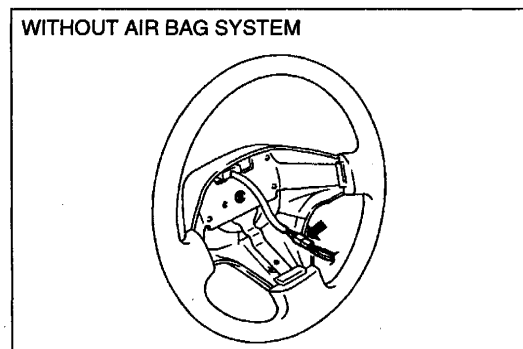
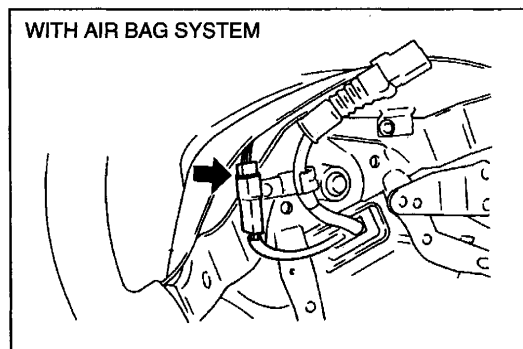

Step 1

Warning

- Handling the air bag module improperly can accidentally deploy the air bag, which may seriously injure you. Read **SERVICE WARNINGS**, page T1-98, before handling the air bag module.

1. Remove the driver-side air bag module. (Refer to page T1-107.)
(With air bag system)
Remove the horn pad. (Without air bag system)
2. Make sure the cruise control switch connector is securely connected to the cruise control switch.

Connection	Action
OK	Go to Step 2
Poor	Reconnect connector

Step 2

1. Disconnect the cruise control switch connector.
2. Measure the resistance between the switch terminals.

Ω : Resistance

Terminal	A	B
Switch position		
SET/COAST	○—Ω—○	○—240 Ω—○

3. If correct, replace the cruise control module. (Refer to page T1-89.)
4. If not as specified, replace the cruise control switch. (Refer to page T1-94.)

Flowchart No.2	Symptom	Diagnostic trouble code 22 is not indicated
----------------	---------	---

Possible cause

- Damaged cruise control module
- Poor connection of connector

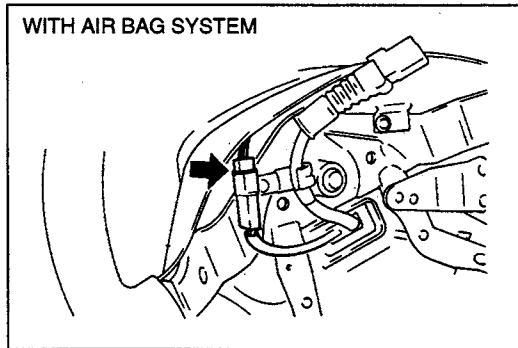

Remedy

Warning

- Handling the air bag module improperly can accidentally deploy the air bag, which may seriously injure you. Read **SERVICE WARNINGS**, page T1-98, before handling the air bag module.

1. Remove the driver-side air bag module.
(Refer to page T1-107.)
(With air bag system)
Remove the horn pad.
(Without air bag module)
2. Make sure the cruise control switch connector is securely connected to the cruise control switch.

Connection	Action
OK	Replace the cruise control module (Refer to page T1-89)
Poor	Reconnect connector

Flowchart No.3	Symptom	Diagnostic trouble code 31 is not indicated
----------------	---------	---

Possible cause

- Burnt STOP 15 A fuse
- Damaged cruise control module
- Damaged brake switch
- Open or short circuit in wiring harness
- Poor connection of connector

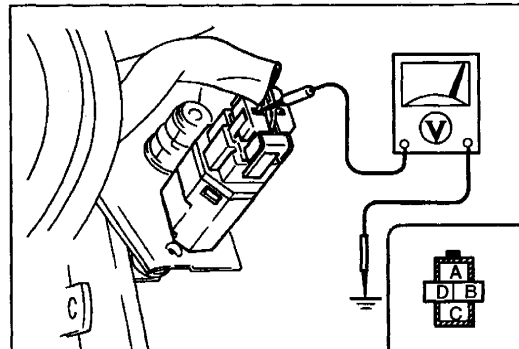
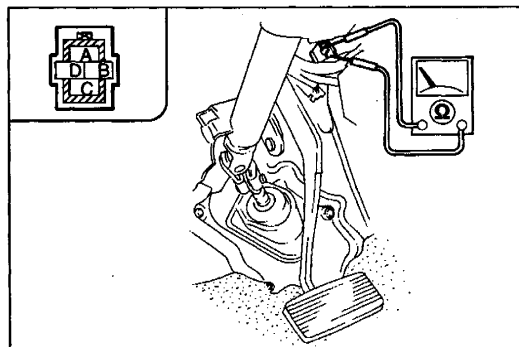
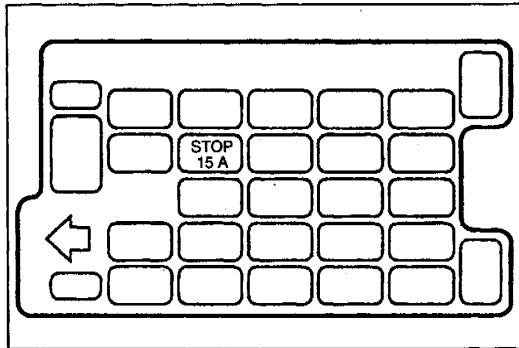

Step 1

Check the STOP 15 A fuse in the fuse block.

Fuse	Action
OK	Go to Step 2
Burnt	Replace fuse after checking and repairing wiring harness

Step 2

1. Disconnect the brake switch connector.
2. Check for continuity between the switch terminals.

○—○: Continuity

Brake pedal	Terminal			
	A	C	B	D
Released			○—○	○—○
Depressed	○—○	○—○		

3. If correct, reconnect the brake switch connector and go to Step 3.
4. If not as specified, replace the brake switch. (Refer to section P.)

Step 3

1. Turn the ignition switch to ON.
2. Turn the cruise control main switch on.
3. Measure the voltage at the terminals of the brake switch connector.

B+: Battery positive voltage

Terminal	Voltage	Action
A (G)	B+	Measure voltage at terminals B and D
	Other	Repair wiring harness (STOP 15 A fuse — Brake switch)
B (P) D (V)	About 9 V	Go to Step 4
	Other	Repair wiring harness (Cruise control module — Brake switch)

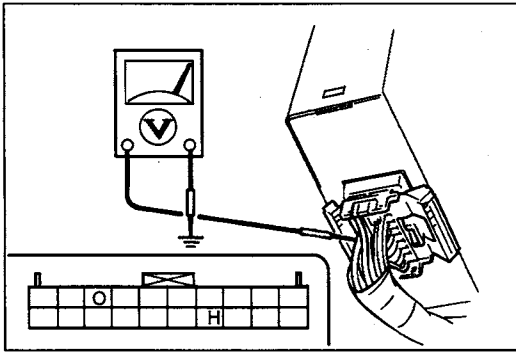

Step 4

1. Pull out the cruise control module with the cruise control module connector connected.
(Refer to page T1-89.)
2. Measure the voltage at the terminals of the cruise control module connector.

B+: Battery positive voltage

Terminal	Voltage	Action
H (V) O (P)	About 9 V	Go to Step 5
	Other	Replace cruise control module (Refer to page T1-89)

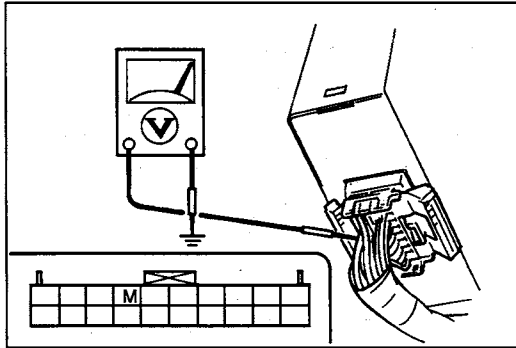

Step 5

1. Depress the brake pedal.
2. Measure the voltage at terminal M (G/Y) of the cruise control module connector.

B+: Battery positive voltage

Voltage	Action
B+	Replace cruise control module (Refer to page T1-89)
Other	Repair wiring harness (Cruise control module — Brake switch)

Flowchart No.4	Symptom	Diagnostic trouble code 35 is not indicated
-----------------------	----------------	---

(ATX vehicle)

Possible cause

- Damaged cruise control module
- Damaged transaxle range switch
- Open or short circuit in wiring harness
- Poor connection of connector

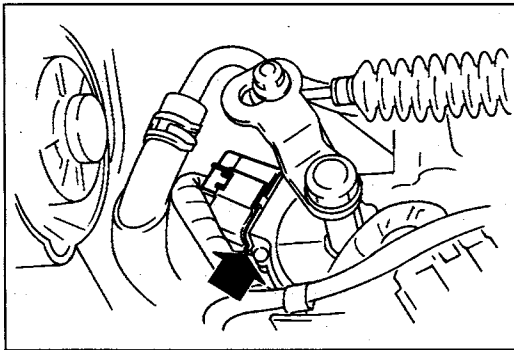

Step 1

1. Remove the air cleaner.
(Refer to sections F1, F2.)
2. Make sure the transaxle range switch connector is securely connected to the transaxle range switch.

Connection	Action
OK	Go to Step 2
Poor	Reconnect connector

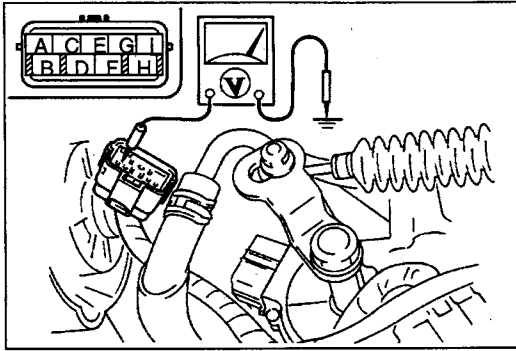

Step 2

1. Disconnect the transaxle range switch connector.
2. Turn the ignition switch to ON.
3. Measure the voltage at terminal H (B/L) of the transaxle range switch connector.

B+: Battery positive voltage

Voltage	Action
B+	Go to Step 3
Other	Repair wiring harness (Ignition switch — Transaxle range switch)

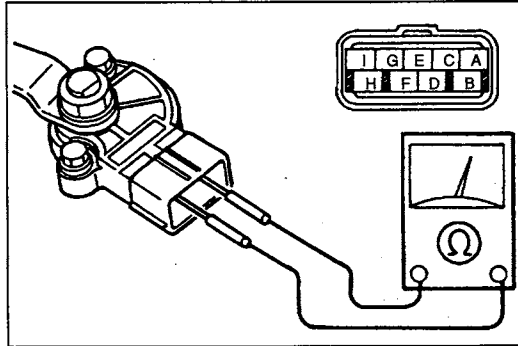

Step 3

1. Check for continuity between the transaxle range switch terminals.

○—○: Continuity

Position	Terminal								
	A	B	C	D	E	F	G	H	I
P		○						○	
R	○								○
N		○						○	
D				○					○
S						○			○
L					○				○

2. If correct, reconnect the transaxle range switch connector and go to Step 4.
3. If not as specified, replace or adjust the transaxle range switch.
(Refer to section K.)

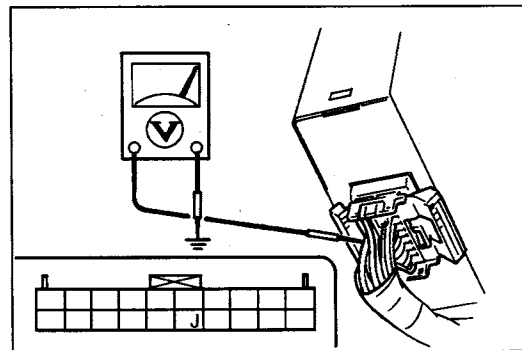

Step 4

1. Turn the ignition switch to LOCK.
2. Pull out the cruise control module with the cruise control module connector connected.
(Refer to page T1-89.)
3. Turn the ignition switch to ON.
4. Measure the voltage at terminal J (B/L) of the cruise control module connector.

B+: Battery positive voltage

Voltage	Action
B+	Replace cruise control module (Refer to page T1-89)
Other	Repair wiring harness (Cruise control module — Transaxle range switch)

(MTX vehicle)

Possible cause

- Damaged cruise control module
- Damaged clutch switch
- Open or short circuit in wiring harness
- Poor connection of connector

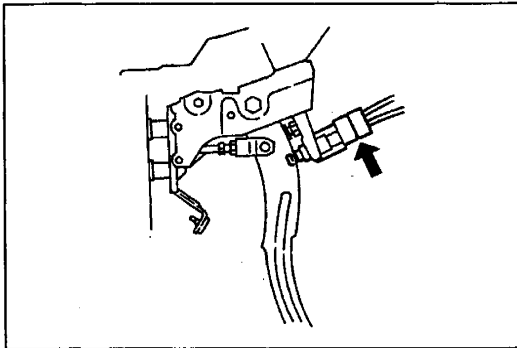

Step 1

Make sure the clutch switch connector is securely connected to the clutch switch.

Connection	Action
OK	Go to Step 2
Poor	Reconnect connector

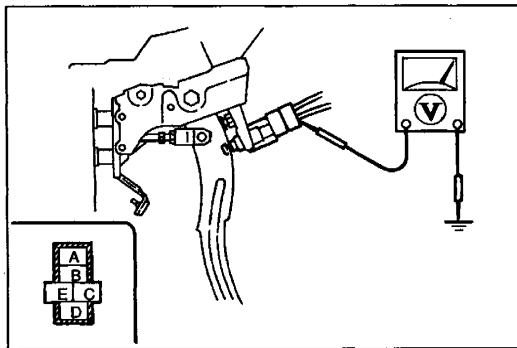

Step 2

1. Turn the ignition switch to ON
2. Measure the voltage at terminal C (BR/B) [USA] or (B/L) [CANADA] of the clutch switch connector.

B+: Battery positive voltage

Voltage	Action
B+	Go to Step 3
Other	Repair wiring harness (Ignition switch — Clutch switch)

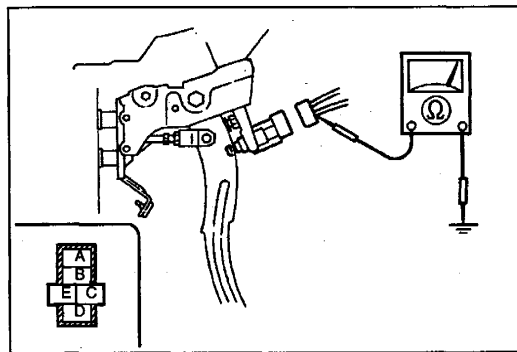

Step 3

1. Turn the ignition switch to LOCK.
2. Disconnect the clutch switch connector.
3. Check for continuity between terminal E (B) of the clutch switch connector and ground.

Continuity	Action
Yes	Go to Step 4
No	Repair wiring harness (Clutch switch — GND)

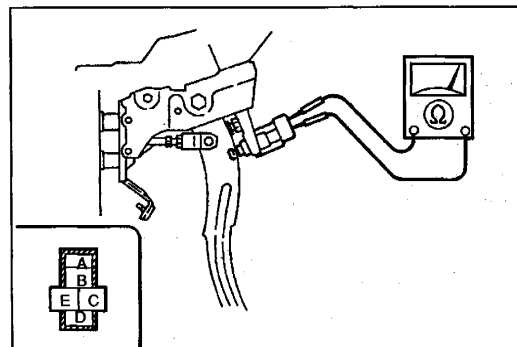

Step 4

1. Check for continuity between the clutch switch terminals.

○—○: Continuity

Clutch pedal	Terminal	
	C	E
Depressed	○—○	○—○
Released		

2. If correct, reconnect the clutch switch connector and go to step 5.
3. If not as specified, replace the clutch switch.
(Refer to section F1, F2.)

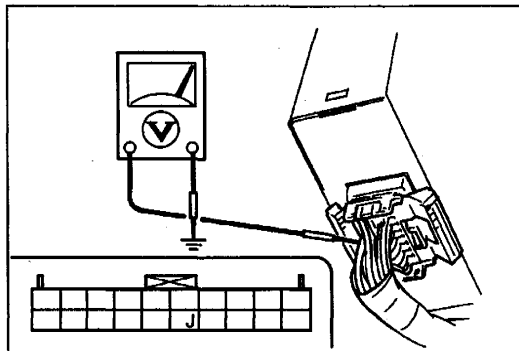

Step 5

1. Remove the cruise control module.
(Refer to page T1-89.)
2. Turn the ignition switch to ON.
3. Measure the voltage at terminal J (B/L) of the cruise control module connector.

B+: Battery positive voltage

Voltage	Action
B+	Replace cruise control module (Refer to page T1-89)
Other	Repair wiring harness (Ignition switch — Cruise control module)

Flowchart No.5	Symptom	Diagnostic trouble code 37 is not indicated
-----------------------	----------------	---

Possible cause

- Damaged cruise control module
- Damaged instrument cluster
- Damaged vehicle speedometer sensor
- Open or short circuit in wiring harness
- Poor connection of connector

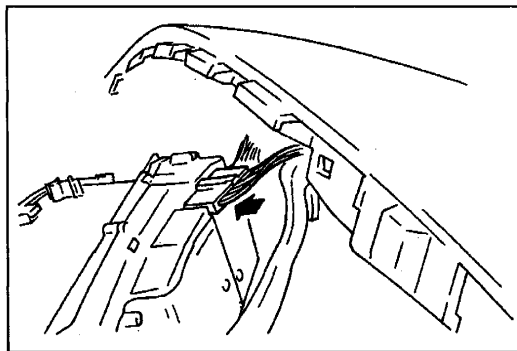

Step 1

1. Remove the instrument cluster.
(Refer to page T1-51.)
2. Make sure the instrument cluster connector is securely connected to the instrument cluster.

Connection	Action
OK	Go to Step 2
Poor	Reconnect connector

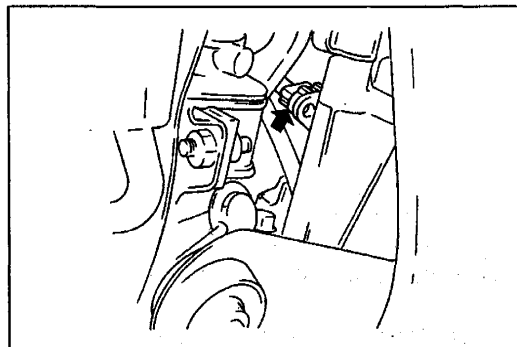

Step 2

1. Remove the splash shield.
(Refer to section K.)
2. Remove the undercover.
(Refer to section K.)
3. Make sure the vehicle speedometer sensor connector is securely connected to the vehicle speedometer sensor.

Connection	Action
OK	Go to Step 3
Poor	Reconnect connector

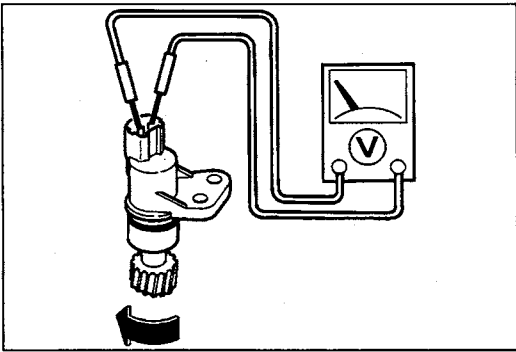

Step 3

1. Remove the vehicle speedometer sensor.
(Refer to section K.)
2. Measure the voltage between the terminals of the vehicle speedometer sensor while rotating the driven gear.

Meter needle	Action
Moves slightly under 5 V	Install vehicle speedometer sensor and go to Step 4
Does not move	Replace vehicle speedometer sensor (Refer to section K)

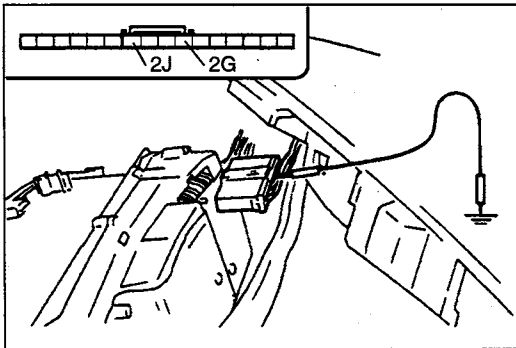

Step 4

1. Disconnect the instrument cluster connector.
2. Connect terminals 2G (GY/L) and 2J (LG/R) of the instrument cluster connector to ground.

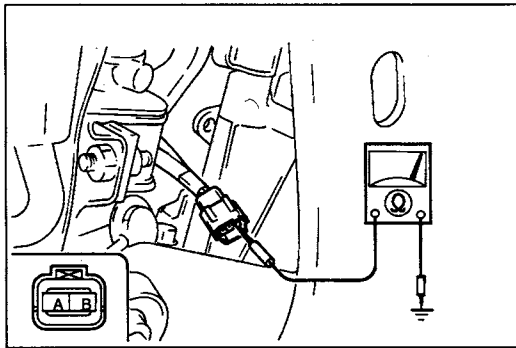

3. Check for continuity between terminals A (LG/R) and B (GY/L) of the vehicle speedometer sensor connector and ground.

Continuity	Action
Yes	Reconnect instrument cluster connector and go to Step 5
No	Repair wiring harness (Instrument cluster — Vehicle speedometer sensor)

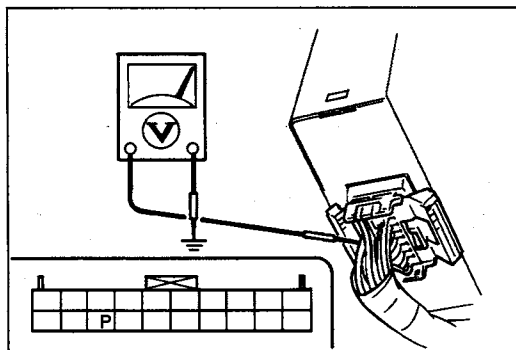

Step 5

1. Pull out the cruise control module with the cruise control module connector connected.
(Refer to page T1-89.)
2. Measure the voltage at terminal P (G/R) of the cruise control module connector while rotating the front tires.

Voltage	Action
2-3 V	Replace cruise control module (Refer to page T1-89)
Other	Go to step 6

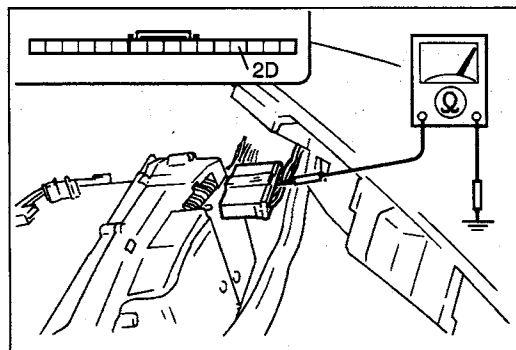

Step 6

1. Disconnect the instrument cluster connector.
2. Disconnect the cruise control module connector.
3. Connect terminal P (G/R) of the cruise control module connector to ground.
4. Check for continuity between terminal 2D (G/R) of the instrument cluster connector and ground.

Continuity	Action
Yes	Replace instrument cluster (Refer to page T1-51)
No	Repair wiring harness (Cruise control module — Instrument cluster)

CRUISE CONTROL MODULE

Removal / Installation

1. Remove the door lock timer unit.
(Refer to section S1.)
2. Remove in the order shown in the figure.
3. Install in the reverse order of removal, referring to **Installation note**.
4. Carry out on-board diagnostic inspection.
(Refer to page T1-69.)

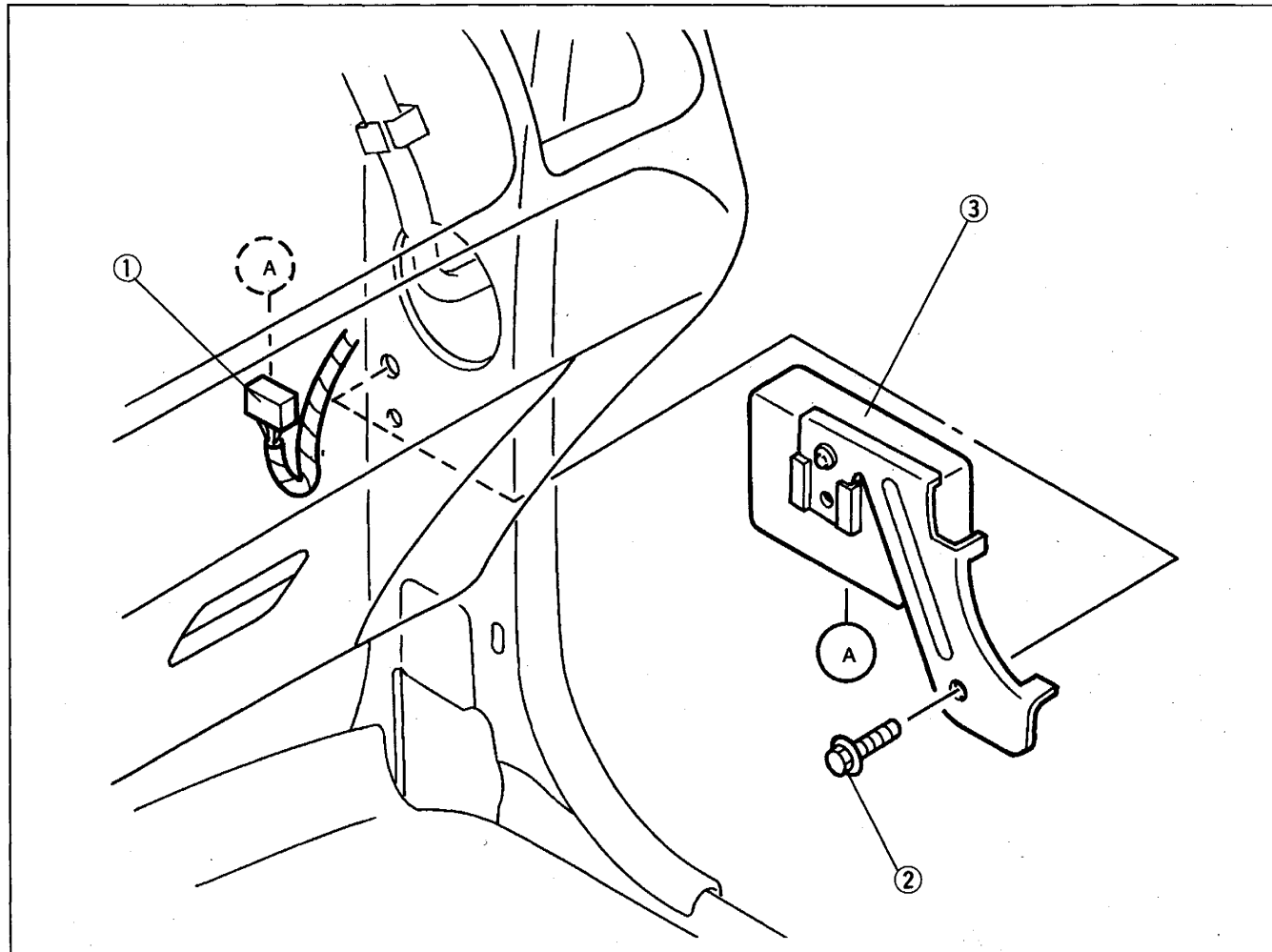

1. Connector

2. Bolt

Installation note below

3. Cruise control module

Installation note below

Inspection page T1-90

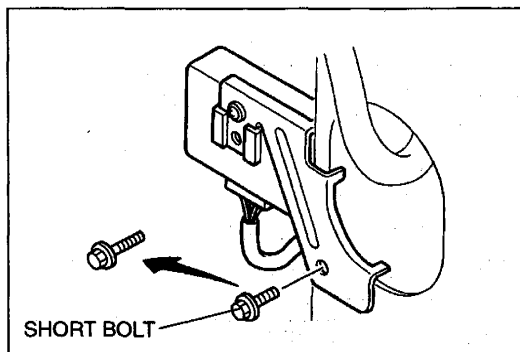

Installation note

Bolt and cruise control module

Because the space between the factory-installed bolt and the blower unit is narrow, use a short bolt when re-installing the cruise control module.

Inspection

1. Pull out the cruise control module with the cruise control module connector connected.
(Refer to page T1-89.)
2. Measure the voltage at the cruise control module terminals as indicated below.
3. If not as specified, inspect the parts listed under "Inspection area" and the related wiring harnesses.
4. If the parts and wiring harnesses are OK but the system still does not work properly, replace the cruise control module.

Terminal voltage list (Reference)

B+: Battery positive voltage

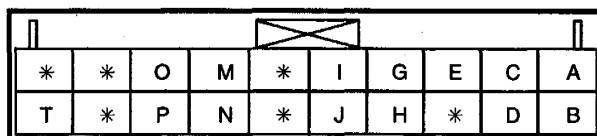

Terminal	Signal	Connection	Test condition		Voltage	Inspection area	
A	Cruise actuator on signal	Vacuum pump (control valve)	Ignition switch at ON	Cruise control main switch on	9 V	<ul style="list-style-type: none"> METER 15 A fuse Cruise control main switch Vacuum pump 	
				Other	0 V		
B	Cruise actuator on signal	Vacuum pump (motor)	Ignition switch at ON	Cruise control main switch on	9 V	<ul style="list-style-type: none"> METER 15 A fuse Cruise control main switch Brake switch Vacuum pump 	
				Other	0 V		
C	Cruise actuator on signal	Vacuum pump (release valve)	Ignition switch at ON	Cruise control main switch on	9 V	<ul style="list-style-type: none"> METER 15 A fuse Cruise control main switch Brake switch Vacuum pump 	
				Other	0 V		
D	IG1	Instrument cluster (cruise set indicator light)	Ignition switch at ON		B+	<ul style="list-style-type: none"> METER 15 A fuse Cruise set indicator light bulb 	
			Cruise set indicator light illuminated		0 V		
E	Cruise control main switch on/off signal	Cruise control main switch	Ignition switch at ON	Cruise control main switch off side pushed	0 V	<ul style="list-style-type: none"> METER 15 A fuse Cruise control main switch 	
				Other	B+		
F	—	—	—		—	—	
G	O/D off signal	PCM	Ignition switch at ON		B+	PCM	
H	Cruise actuator on signal	Vacuum pump	Ignition switch at ON and cruise control main switch on	Release brake pedal	B+	<ul style="list-style-type: none"> METER 15 A fuse Cruise control main switch 	
				Depress brake pedal	9 V		
I	TEST signal	Data link connector	—		—	—	
J	ATX	Selector lever position signal	Transaxle range switch	Ignition switch at ON	N or P range	0 V	Transaxle range switch
					Other	B+	
	MTX	Clutch switch on signal	Clutch switch	Ignition switch at ON	Depress clutch pedal	0 V	Clutch switch
					Other	B+	
K	—	—	—		—	—	
L	—	—	—		—	—	

Cont'd

B+: Battery positive voltage

Terminal	Signal	Connection	Test condition	Voltage/Continuity	Inspection area	
M	Brake on signal	Brake switch	Depress brake pedal	B+	<ul style="list-style-type: none"> • STOP 15 A fuse • Brake switch 	
			Other	0 V		
N	Cruise control switch on signal	Cruise control switch	Ignition switch at ON and cruise control main switch on	5 V	<ul style="list-style-type: none"> • METER 15 A fuse • Cruise control main switch • Clock spring • Cruise control switch 	
			Ignition switch at ON and cruise control main switch on	SET/COAST switch pushed		0 V
				CANCEL switch pushed (without air bag system)		0 V
O	Brake on signal	Brake switch	Ignition switch at ON and cruise control main switch on	Release brake pedal	B+	
			Depress brake pedal	0 V	<ul style="list-style-type: none"> • METER 15 A fuse • Cruise control main switch • Brake switch 	
P	Vehicle speedometer sensor on signal	Vehicle speedometer sensor	Front tires rotating	Alternates 0 V and 5 V	<ul style="list-style-type: none"> • Vehicle speedometer sensor • Instrument cluster 	
Q	—	—	—	—	—	
R	—	—	—	—	—	
S	—	—	—	—	—	
T	GND	GND	Check for continuity to ground	Yes	GND	

**CRUISE ACTUATOR
Removal / Installation**

1. Remove the actuator cable.
(Refer to page T1-93.)
2. Disconnect the vacuum pump connector.
3. Remove in the order shown in the figure.
4. Install in the reverse order of removal.
5. Adjust the actuator cable.
(Refer to page T1-93.)

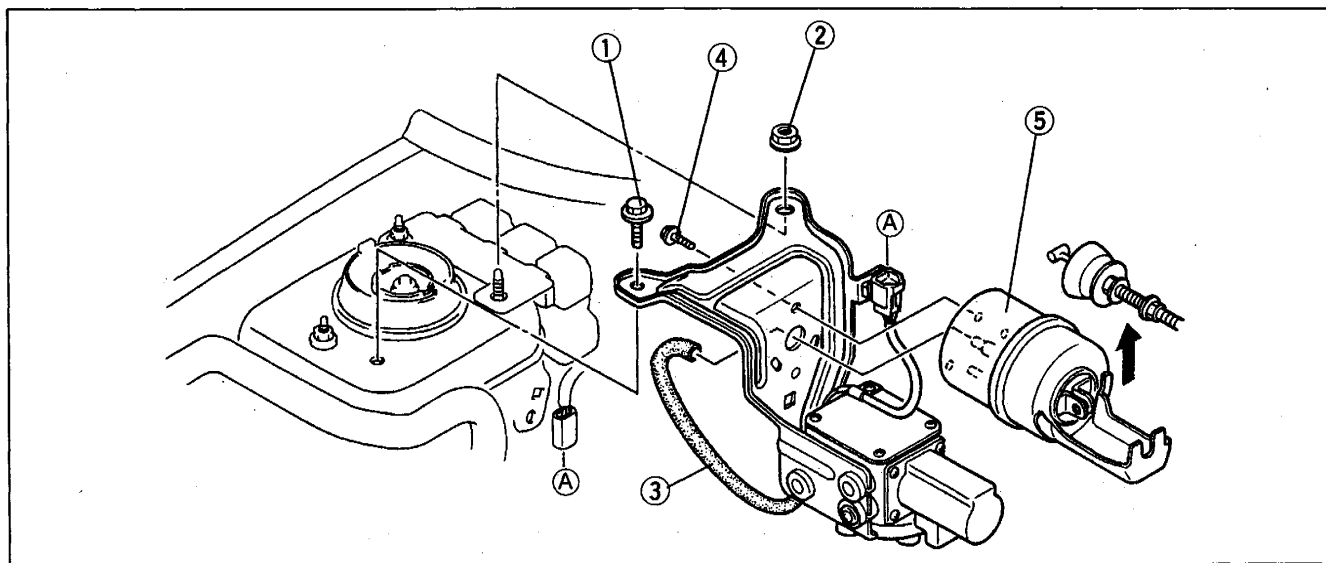

1. Bolt
2. Nut
3. Vacuum hose

4. Screw
5. Cruise actuator

Inspection page T1-92

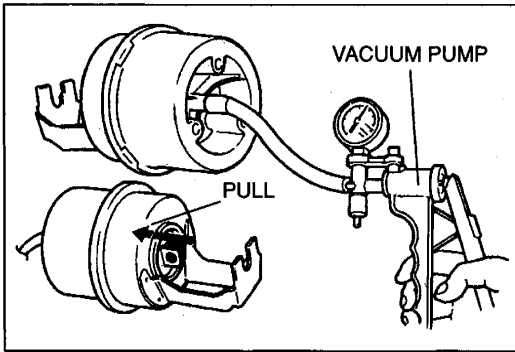

Inspection

1. Remove the cruise actuator.
(Refer to page T1-91.)
2. Connect a vacuum pump to the cruise actuator.
3. Verify that the diaphragm of the cruise actuator is pulled when applying a vacuum of more than **38.7 kPa { 290 mmHg , 11.4 inHg }**.
4. If not as specified, replace the cruise actuator.
(Refer to page T1-91.)

VACUUM PUMP

Removal / Installation

1. Disconnect the vacuum pump connector.
2. Remove in the order shown in the figure.
3. Install in the reverse order of removal.

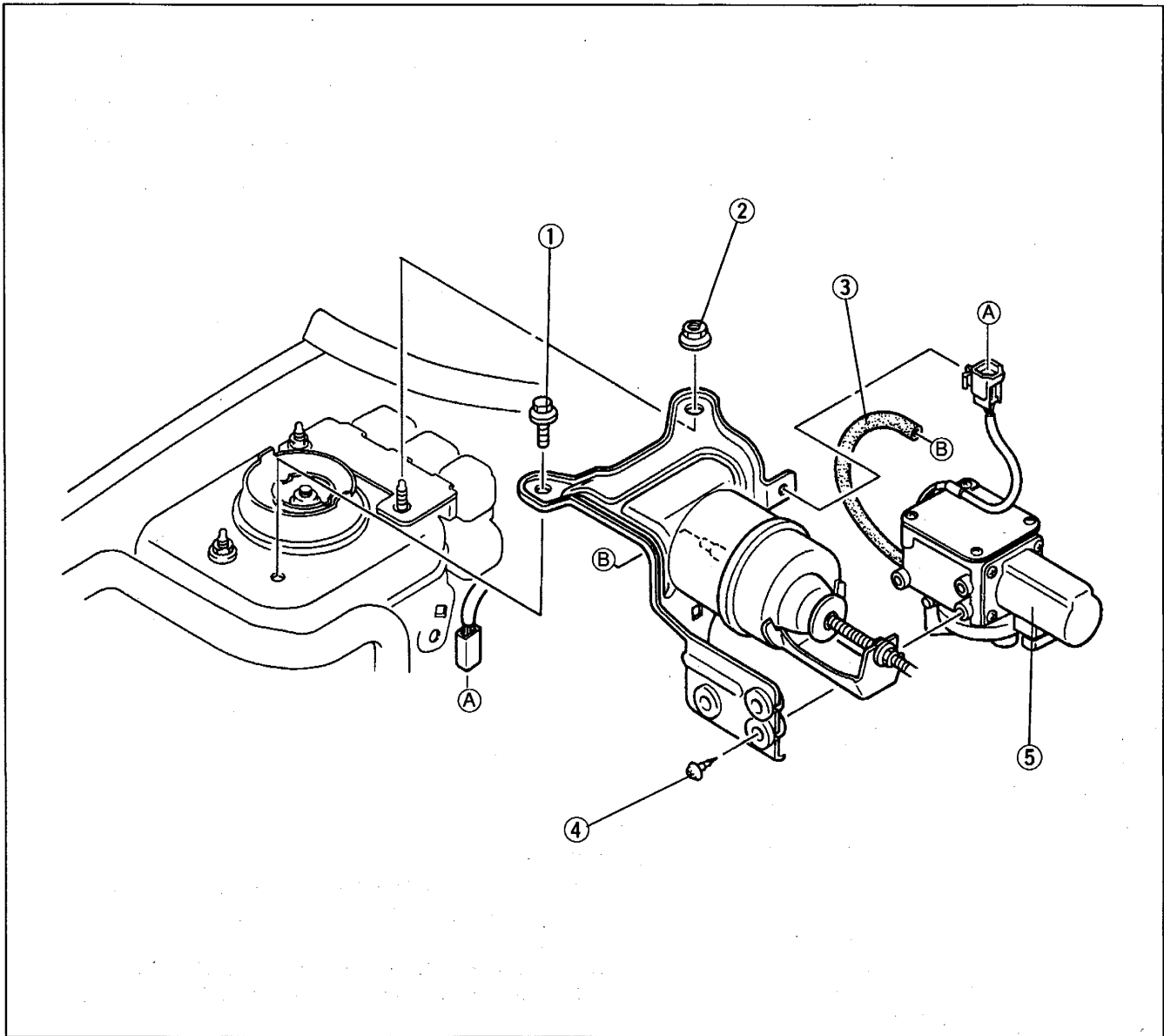

1. Bolt
2. Nut
3. Vacuum hose

4. Screw
5. Vacuum pump

Inspection page T1-93

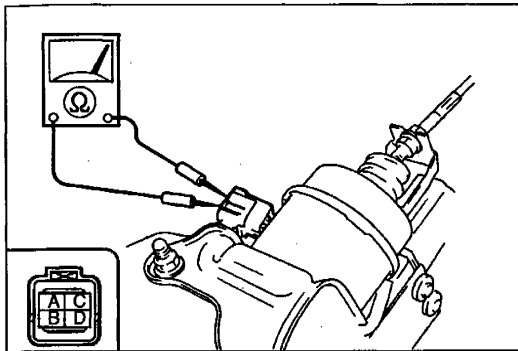

Inspection

1. Disconnect the vacuum pump connector
2. Measure the resistance between the cruise actuator terminals.

Terminals	Resistance (Ω)
A—C	55
A—B	
A—D	6
B—C	110
B—D	60
C—D	

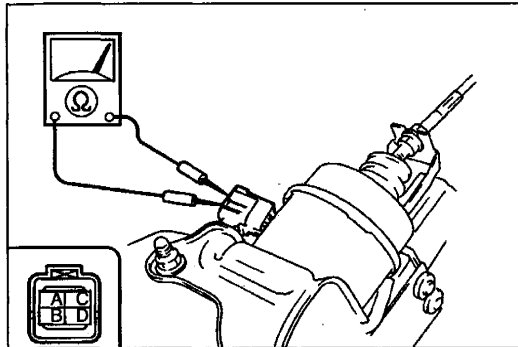

3. Connect battery positive voltage and verify the operation of the actuator cable as indicated below.

B+: Battery positive voltage

Step	Terminal connection				Actuator cable operation
	A	B	C	D	
1	B+	GND	GND	GND	Pull
2	B+	GND	GND	—	Hold
3	B+	GND	—	—	Extend
4	—	—	—	—	Release

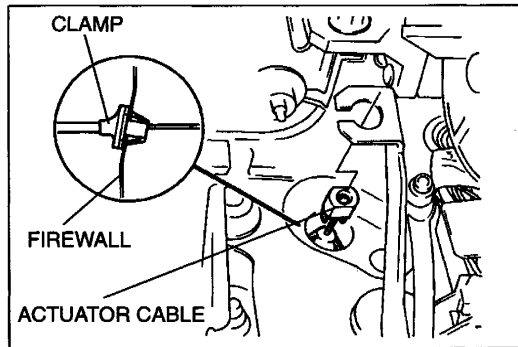

4. If not as specified, replace the vacuum pump.
(Refer to page T1-92.)

**ACTUATOR CABLE
Removal / Installation**

1. Disconnect the actuator cable from the accelerator pedal.
2. Remove the clamp at the inside of the firewall.

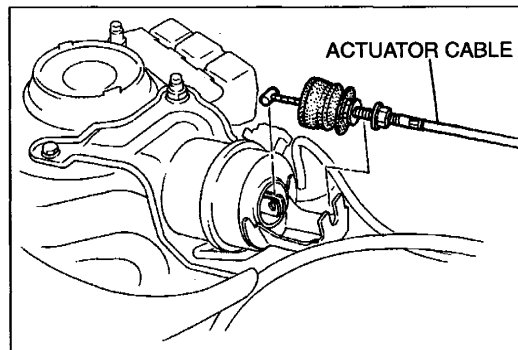

3. Loosen the nut and remove the actuator cable from the cruise actuator.
4. Install in the reverse order of removal.

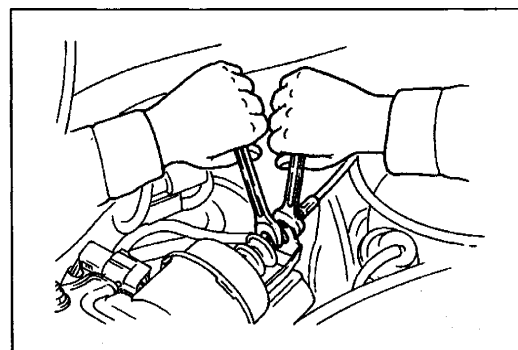

Adjustment

Adjust the nut so that actuator cable free play is as specified, when the actuator cable is pressed lightly.

Cable play on bolt the cruise actuator side and throttle body side: 1.0—5.0 mm { 0.04—0.19 in }

CRUISE CONTROL SWITCH Removal / Installation With air bag system

Warning

- Handling the air bag module improperly can accidentally deploy the air bag, which may seriously injure you. Read **SERVICE WARNINGS**, page T1-98, before handling the air bag module.

1. Remove the driver-side air bag module.
(Refer to page T1-107.)
2. Remove in the order shown in the figure.
3. Install in the reverse order of removal.

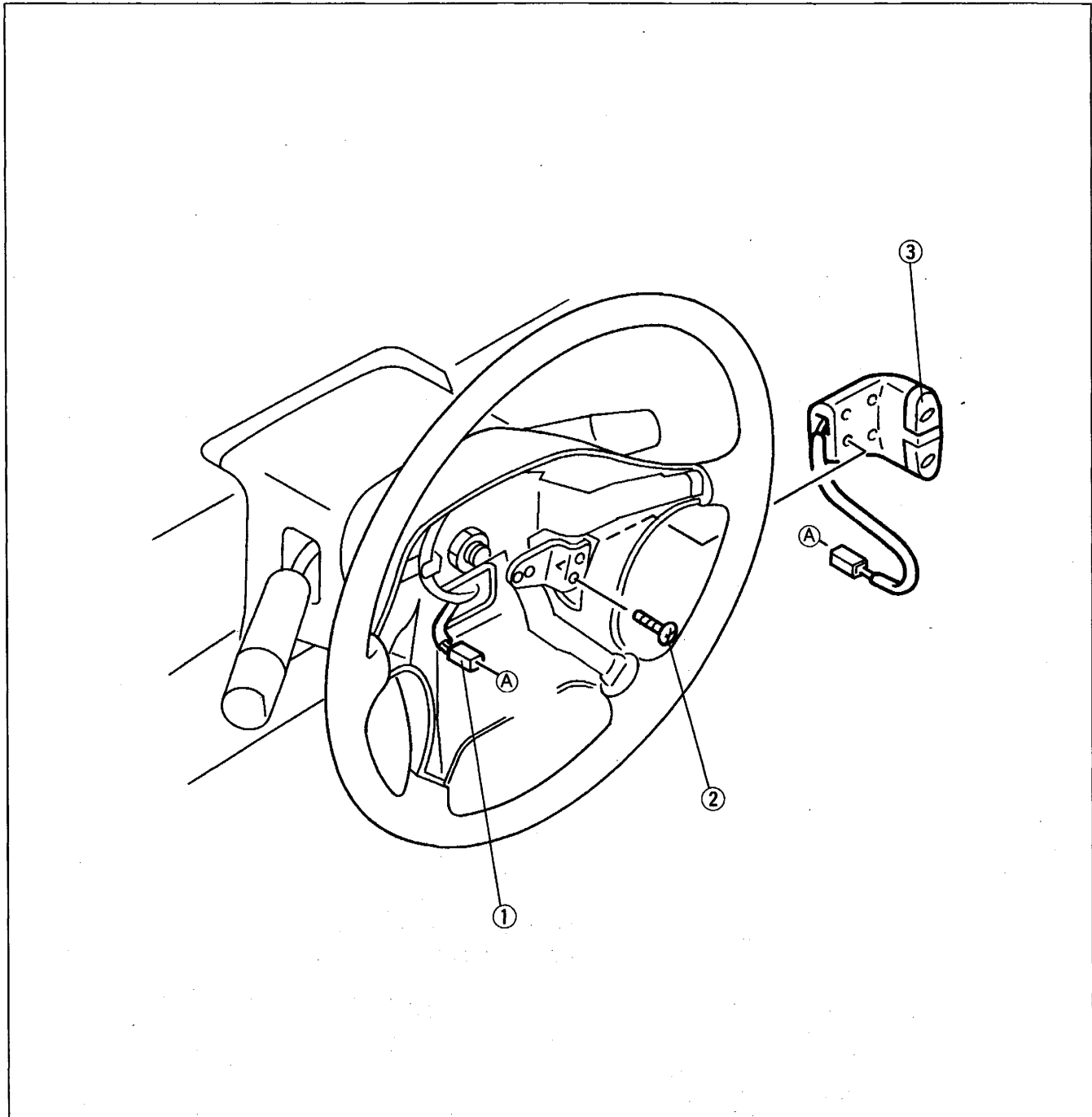

1. Connector
2. Screw

3. Cruise control switch
Inspection page T1-95

Without air bag system

1. Remove the horn pad.
2. Remove in the order shown in the figure.
3. Install in the reverse order of removal.

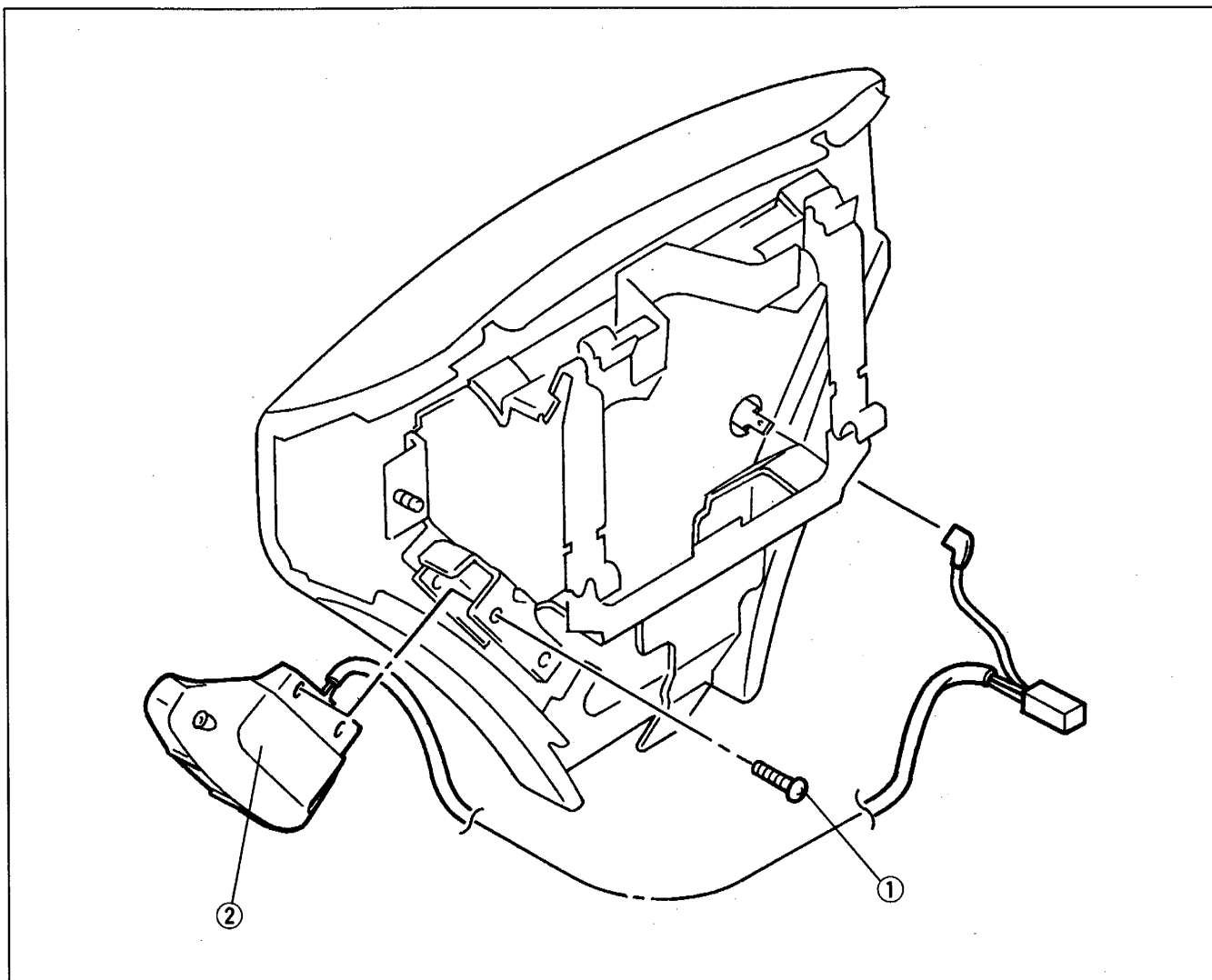

1. Screw

2. Cruise control switch
Inspection below

Inspection

1. Remove the driver-side air bag module.
(Refer to page T1-107.)
(With air bag system)
Remove the horn pad.
(Without air bag system)
2. Check for continuity between the switch terminals.

○-Ω-○ : Resistance ○-○ : Continuity

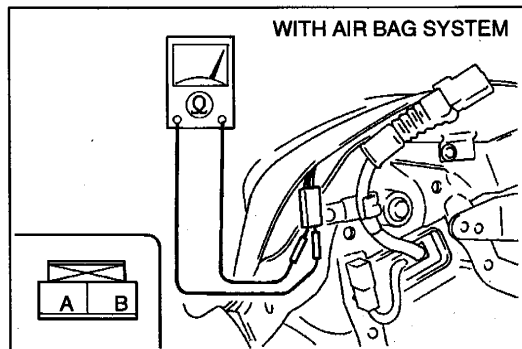

Terminal	A	B
SET/COAST	○-Ω-○	○ 240 Ω
RES/ACCEL	○-Ω-○	○ 910 Ω
CANCEL (without air bag system)	○-○	○-○

3. If not as specified, replace the cruise control switch.

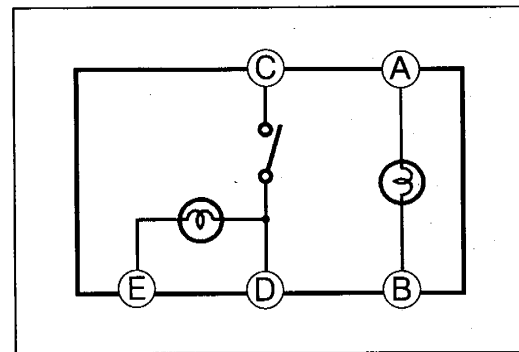
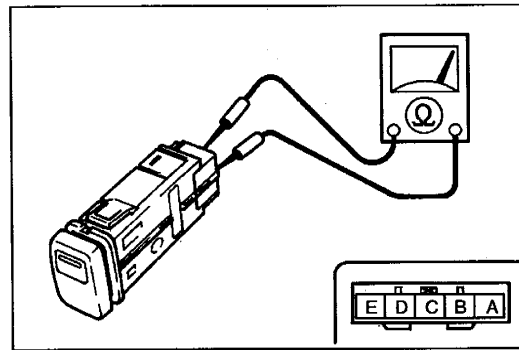
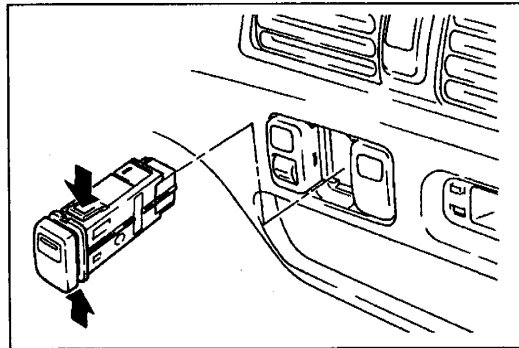
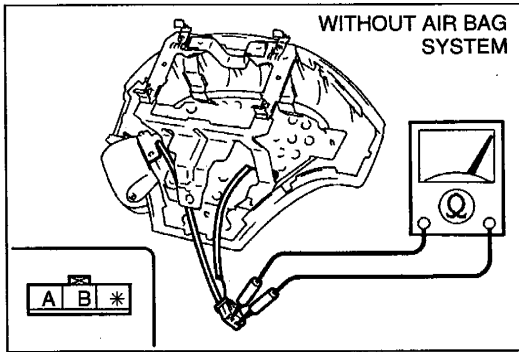

**CRUISE CONTROL MAIN SWITCH
Removal / Installation**

1. Remove the meter hood.
(Refer to section S1.)
2. Remove in the order shown in the figure.
3. Install in the reverse order of removal.

Inspection

1. Remove the cruise control main switch.
2. Check for continuity between the switch terminals.



○—○ : Continuity ○—⊗—○ : Bulb

Terminal Switch position		C	D	E	A	B
		Cruise control main switch	ON	○—○	○—⊗—○	○—○
Cruise control main switch	OFF		○—⊗—○		○—○	○—⊗—○

3. If not as specified, replace the cruise control main switch.

AIR BAG SYSTEM

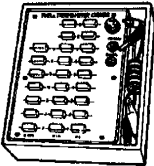
**PREPARATION
SST**

<p>49 0839 285</p> <p>Checker, fuel thermometer</p> 	<p>For inspection of air bag system</p>	<p>49 H066 002</p> <p>Deployment tool</p> 	<p>For deployment of air bag module</p>
---	---	---	---

STRUCTURAL VIEW

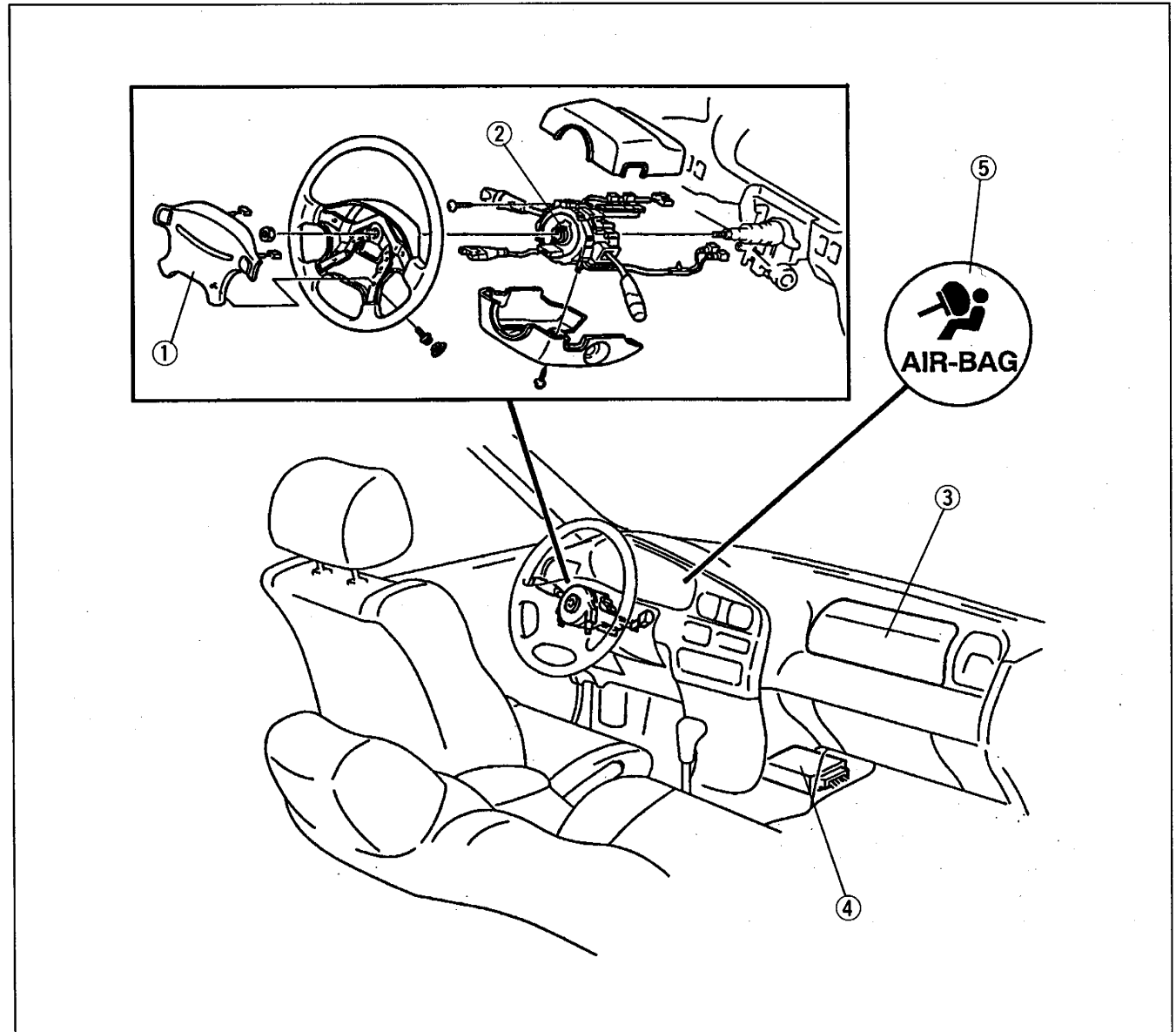

- 1. Driver-side air bag module
Removal / Installation page T1-107
Disposal procedure page T1-110
- 2. Clock spring
Inspection page T1- 25

- 3. Passenger-side air bag module
Removal / Installation page T1-108
Disposal procedure page T1-110
- 4. SAS unit
Removal / Installation page T1-109
- 5. Air bag system warning light

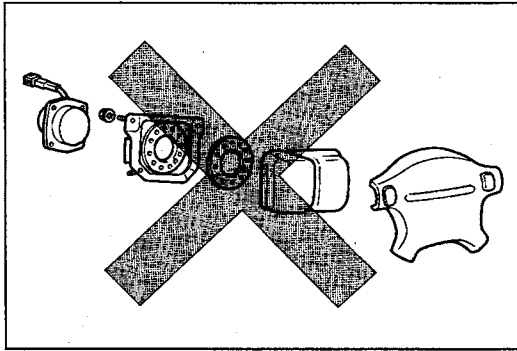
**SERVICE WARNINGS****Component Disassembly**

- Disassembling and reassembling the components of the air bag system can render the system inoperative, which may result in serious injury or death in the event of an accident. Do not disassemble any air bag system components.

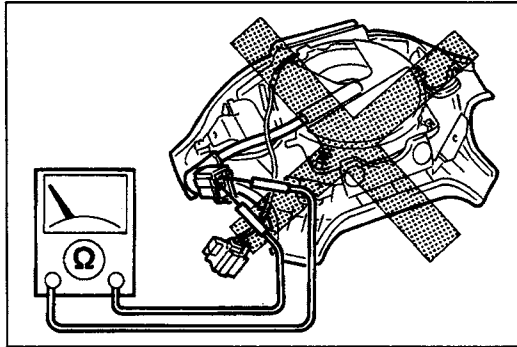
**Air Bag Module Inspection**

- Inspecting the air bag module with an ohmmeter can deploy the air bag, which can cause serious injury. Do not use an ohmmeter to inspect the air bag module.

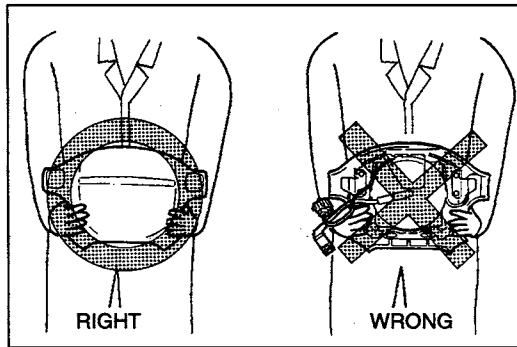
**Air Bag Module Handling**

- A live (undeployed) air bag may accidentally deploy when it is handled and cause serious injury. When carrying a live air bag module, point the trim cover away from your body to lessen the chance of injury in case it deploys.

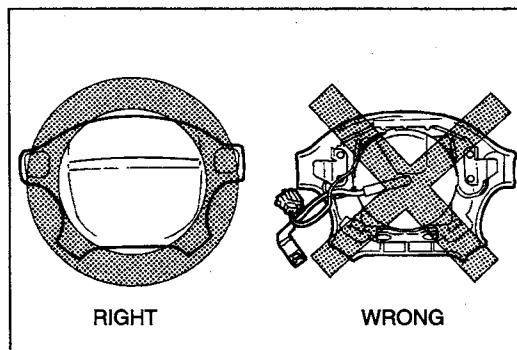

- A live air bag placed face down on a surface is dangerous. If the air bag deploys, the motion of the module can cause serious injury. Always face the trim cover up to reduce the motion of the module in case it accidentally deploys.

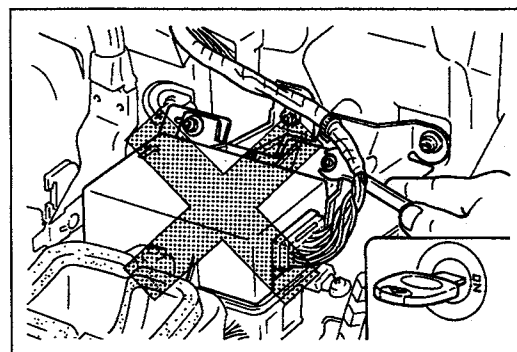
**SAS unit Handling**

- Disconnecting the SAS unit connector or removing the SAS unit with the ignition switch at ON can cause the air bags to deploy, which may seriously injure you. Before disconnecting the SAS unit connector or removing the SAS unit, turn the ignition switch to LOCK.

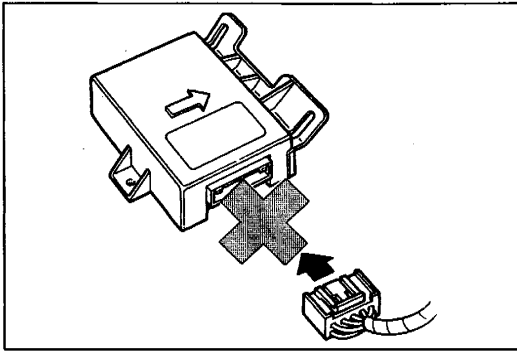

- Connecting the SAS unit connector before installing the SAS unit is dangerous. The shock of installation can cause the air bags to deploy, which may seriously injure you. Before connecting the SAS-unit connector, firmly mount the SAS unit to the vehicle.

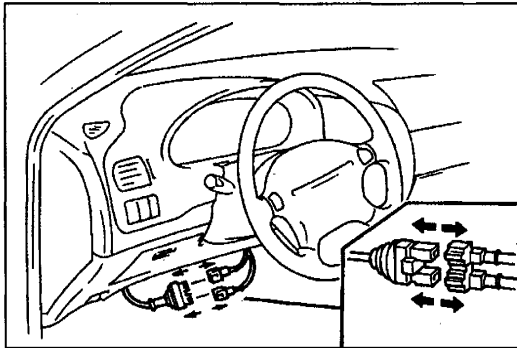

GENERAL PROCEDURES

Before Servicing

1. Turn the ignition switch to LOCK.
2. Disconnect the negative battery cable and wait for more than one minute to allow the backup power supply to deplete its stored power.
3. Disconnect the orange and blue clock spring connectors.

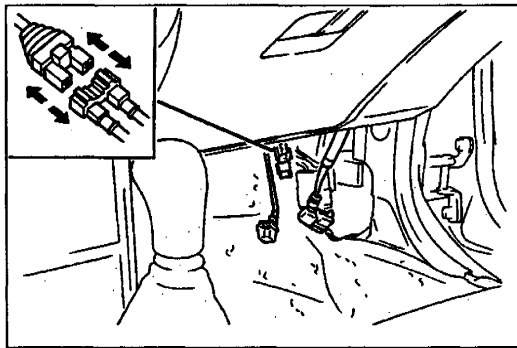

4. Remove the passenger-side scuff plate and front side trim.
(Refer to section S1.)
5. Disconnect the orange and blue passenger-side air bag module connector.

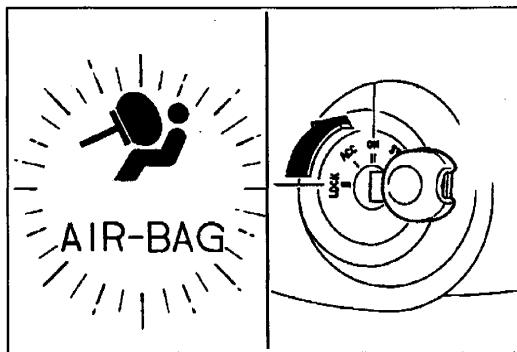

After Servicing

1. Connect the negative battery cable.
2. Turn the ignition switch to ON.
3. Verify that the air bag system warning light illuminates for 4—8 seconds and then goes off.

TROUBLESHOOTING



Troubleshooting Procedure

The SAS unit has an on-board diagnosis function that flashes or illuminates the air bag system warning light to indicate trouble in the air bag system. The trouble can be determined by the warning light illumination or flashing pattern. If the light does not illuminate but the system still has trouble, a warning buzzer will sound 5 cycles of 5 times each.

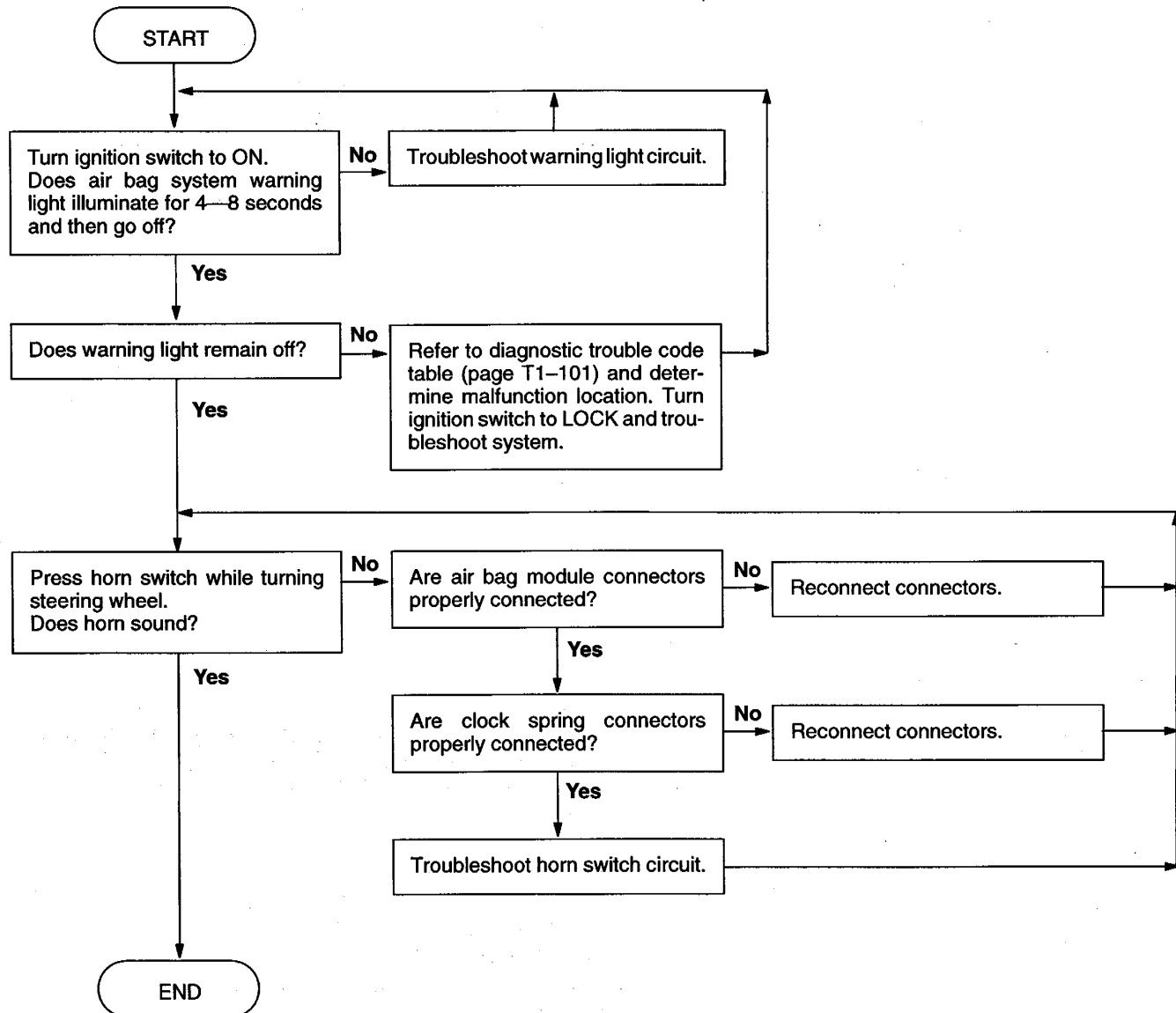
Flowchart



Diagnostic Trouble Code Table

Priority	Code No.	Warning light indication	Possible cause	Inspection area	Refer to page
1	0	Remains on	SAS unit	SAS unit connector	T1-101
2	3		Battery	<ul style="list-style-type: none"> Battery Wiring harness (Battery — ENGINE 10 A fuse — SAS unit, Battery — METER 15 A fuse — SAS unit) 	T1-102
3	6		Driver-side air bag module	<ul style="list-style-type: none"> Clock spring Wiring harness (Clock spring — SAS unit) 	T1-103
4	7		Passenger-side air bag module	Wiring harness (Passenger-side air bag module — SAS unit)	T1-105

Flowchart No.1	Symptom	Air bag system warning light remains on
-----------------------	----------------	---

Possible cause

- Damaged SAS unit
- Open or short circuit in wiring harness
- Poor connection of connector

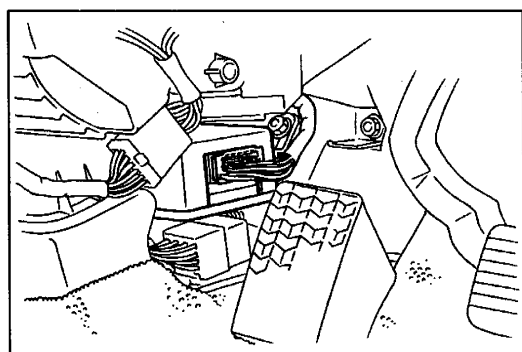

Remedy

Warning

- Handling the SAS unit improperly can accidentally deploy the air bags, which may seriously injure you. Read SERVICE WARNINGS, page T1-98, before handling the SAS unit.

1. Carry out the "Before Servicing" procedure under GENERAL PROCEDURES, page T1-99.
2. Remove the right side wall. (Refer to section S1.)
3. Make sure the SAS unit connector is securely connected to the SAS unit.

Connection	Action
OK	Replace SAS unit (Refer to page T1-109)
Poor	Reconnect connector

Flowchart No.2	Symptom	Diagnostic trouble code 3
-----------------------	----------------	---------------------------

Possible cause

- Weak battery
- Poor connection of connector

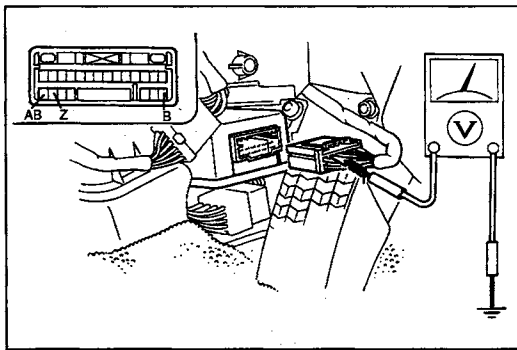
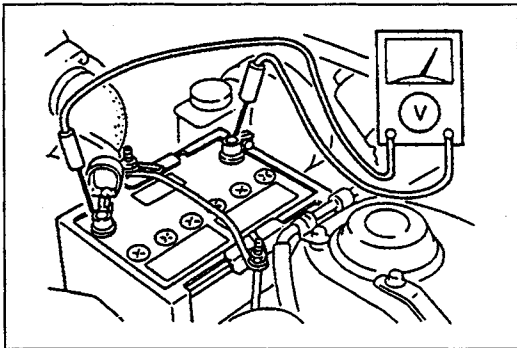

Step 1

Measure the battery voltage.

Voltage	Action
More than 8 V	Go to Step 2
Less than 8 V	Battery is weak Check charge/discharge system (Refer to section G)

Step 2

Warning

- Handling the SAS unit improperly can accidentally deploy the air bags, which may seriously injure you. Read **SERVICE WARNINGS**, page T1-98, before handling the SAS unit.

1. Carry out the "Before Servicing" procedure under **GENERAL PROCEDURES**, page T1-99.
2. Remove the right side wall.
(Refer to section S1.)
3. Disconnect the SAS unit connector.
4. Connect the negative battery cable.
5. Turn the ignition switch to ON.
6. Measure the voltage at the terminals of the SAS unit connector.

Terminal	Voltage	Action
B (B/W) Z (B/W)	More than 8 V	Measure voltage at terminal AB
	Less than 8 V	Repair wiring harness (Battery — ENGINE 10 A fuse — SAS unit)
AB (B/Y)	More than 8 V	Replace SAS unit (Refer to page T1-109)
	Less than 8 V	Repair wiring harness (Battery — METER 15 A fuse — SAS unit)

Flowchart No.3	Symptom	Diagnostic trouble code 6
----------------	---------	---------------------------

Possible cause

- Damaged driver-side air bag module
- Damaged clock spring
- Damaged SAS unit
- Open or short circuit in wiring harness
- Poor connection of connector

Warning

- Handling the air bag module and SAS unit improperly can accidentally deploy the air bag, which may seriously injure you. Read SERVICE WARNINGS, page T1-98, before handling the air bag module and SAS unit.

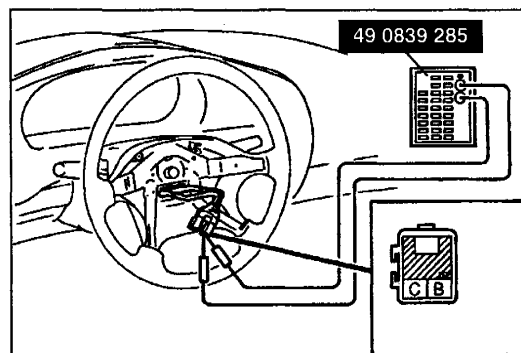
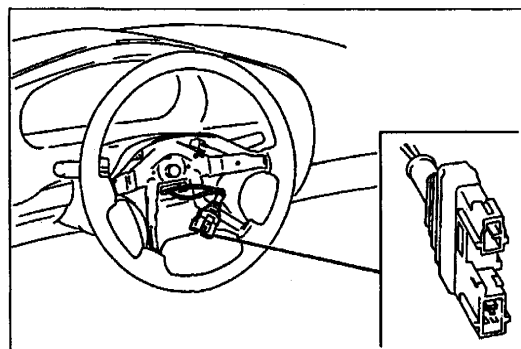

Step 1

1. Carry out the “Before Servicing” procedure under GENERAL PROCEDURES, page T1-99.
2. Remove the driver-side air bag module. (Refer to page T1-107.)
3. Verify that the driver-side air bag module connector pin is not broken.

Pin	Action
OK	Go to Step 2
Broken	Replace combination switch (Refer to page T1-21)

Step 2

1. Connect the leads of the SST to terminals B and C of the driver-side air bag module connector.
2. Set the resistance of the SST to 2 ohms.
3. Connect the clock spring connector.
4. Connect the negative battery cable.
5. Turn the ignition switch to ON and check the diagnostic trouble code.

Diagnostic trouble code	Action
6	Go to Step 3
Other	Replace driver-side air bag module (Refer to page T-107)

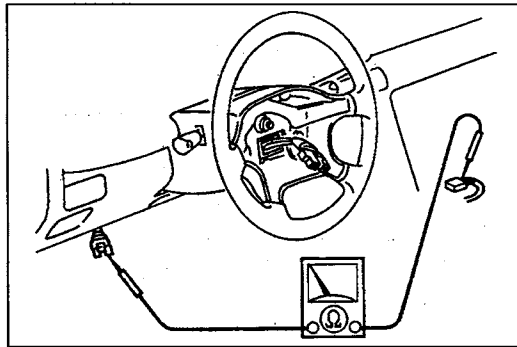
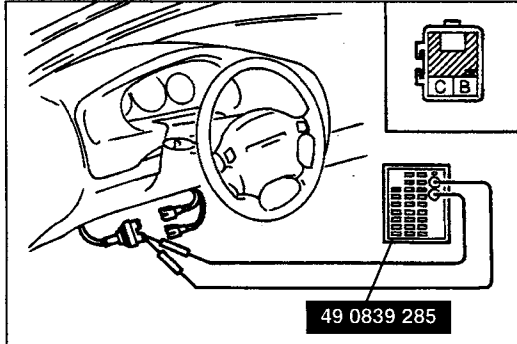
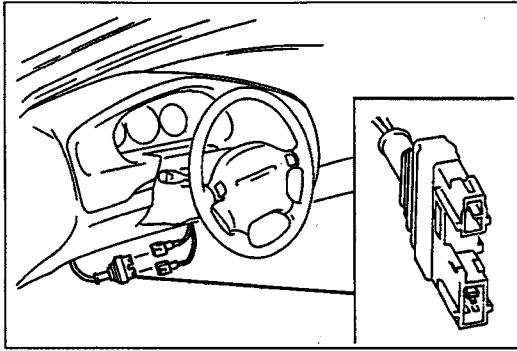

Step 3

1. Turn the ignition switch to LOCK.
2. Disconnect the negative battery cable and wait for more than one minute to allow the backup power supply to deplete its stored power.
3. Disconnect the clock spring connector.
4. Verify that the clock spring connector.

Pin	Action
OK	Go to Step 4
Broken	Repair wiring harness (Clock spring — SAS unit)

Step 4

1. Connect the leads of the **SST** to terminals B and C of the clock spring connector.
2. Set the resistance of the **SST** to 2 ohms.
3. Connect the negative battery cable.
4. Turn the ignition switch to ON and check the diagnostic trouble code.

Diagnostic trouble code	Action
6	Go to Step 5
Other	Replace combination switch (Refer to page T1-21)

Step 5

1. Turn the ignition switch to LOCK.
2. Disconnect the negative battery cable and wait for more than one minute to allow the backup power supply to deplete its stored power.
3. Remove the right side wall.
(Refer to section S1.)
4. Disconnect the SAS unit connector.
5. Check the wiring harness between the terminals of the SAS unit connector and the clock spring connector for the following.
 - Ground short circuit
 - Line short circuit
 - Open circuit
6. If the wiring harness is normal, replace the SAS unit.
(Refer to page T1-109.)
7. If the wiring harness is faulty, repair it.
(Clock spring — SAS unit)

Flowchart No.4	Symptom	Diagnostic trouble code 7
-----------------------	----------------	---------------------------

Possible cause

- Damaged passenger-side air bag module
- Damaged SAS unit
- Open or short circuit in wiring harness
- Poor connection of connector

Warning

- **Handling the air bag module and SAS unit improperly can accidentally deploy the air bag, which may seriously injure you. Read SERVICE WARNINGS, page T1-98, before handling the air bag module and SAS unit.**

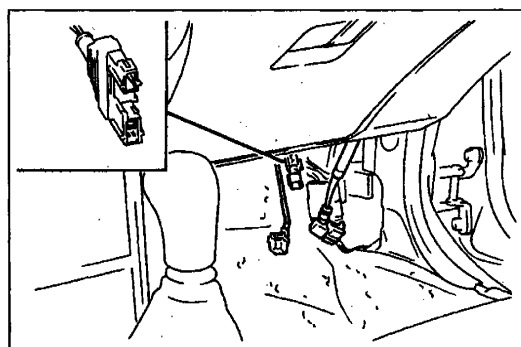

Step 1

1. Carry out the "Before Servicing" procedure under GENERAL PROCEDURES, page T1-99.
2. Verify that the passenger-side air bag module connector pin is not broken.

Pin	Action
OK	Go to Step 2
Broken	Repair wiring harness (Passenger-side air bag module — SAS unit)

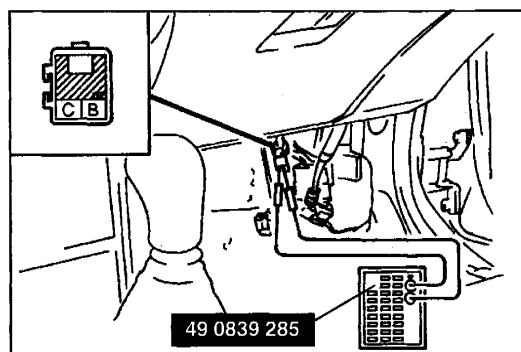

Step 2

1. Connect the leads of the SST to terminals B and C of the passenger-side air bag module connector.
2. Set the resistance of the SST to 2 ohms.
3. Connect the clock spring connector.
4. Connect the negative battery cable.
5. Turn the ignition switch to ON and check the diagnostic trouble code.

Diagnostic trouble code	Action
7	Go to Step 3
Other	Replace passenger-side air bag module (Refer to page T1-108)

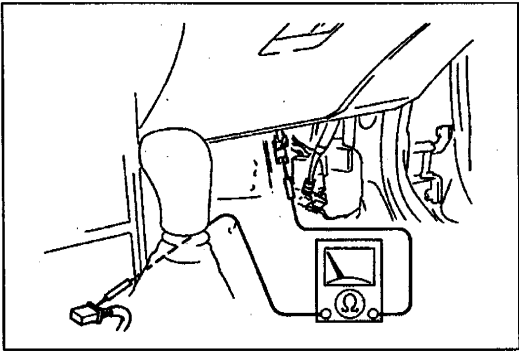
**Step 3**

1. Turn the ignition switch to LOCK.
2. Disconnect the negative battery cable and wait for more than one minute to allow the backup power supply to deplete its stored power.
3. Disconnect the clock spring connector.
4. Remove the right side wall.
(Refer to section S1.)
5. Disconnect the SAS unit connector.
6. Check the wiring harness between the terminals of the SAS unit connector and the passenger-side air bag module connector for the following.
 - Ground short circuit
 - Line short circuit
 - Open circuit
7. If the wiring harness is normal, replace the SAS unit.
(Refer to page T1-109.)
8. If the wiring harness is faulty, repair it.
(Passenger-side air bag module — SAS unit)

DRIVER-SIDE AIR BAG MODULE
Removal / Installation

Warning

- Handling the air bag module improperly can accidentally deploy the air bag, which may seriously injure you. Read **SERVICE WARNINGS**, page T1-98, before handling the air bag module.

Warning

- Installing the driver-side air bag module when a service code 6 is not indicated can accidentally deploy the air bag, which can cause serious injury. Carry out the proper troubleshooting procedures and verify that service code 6 is indicated before installing the driver-side air bag module.

1. Carry out the "Before Servicing" procedure under **GENERAL PROCEDURES**, page T1-99.
2. Remove in the order shown in the figure.
3. Install in the reverse order of removal, referring to **Installation note**.
4. Follow the troubleshooting flowchart (page T1-100) to verify that the air bag system is operating normally.

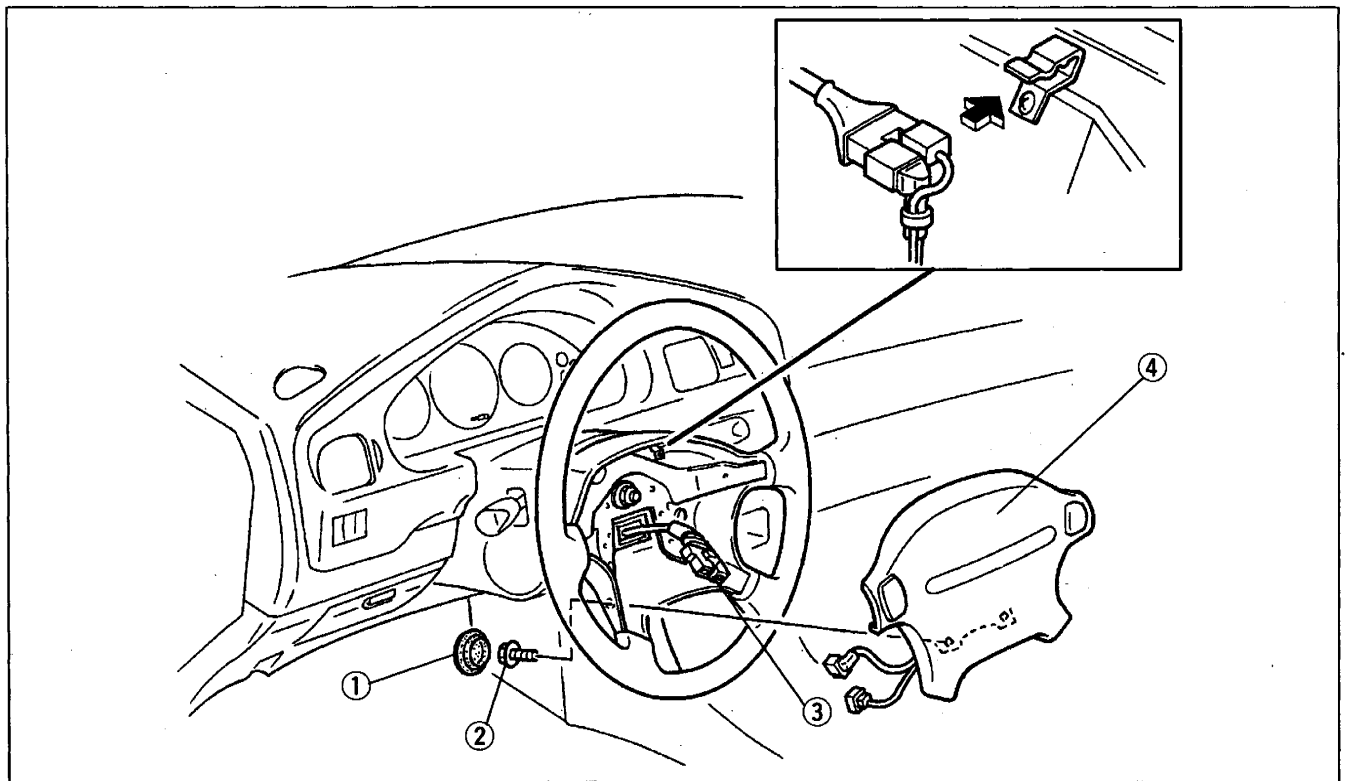

1. Cover
2. Bolt

3. Connector
4. Driver-side air bag module

Installation note below

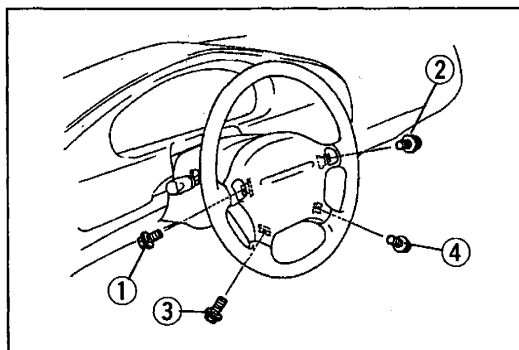

Installation note

Bolts

Tighten the bolts in the order shown in the figure.

Tightening torque:

7.9—11.7 N·m { 80—120 kgf·cm , 70—104 in·lbf }

PASSENGER-SIDE AIR BAG MODULE

Removal / Installation

Warning

- Handling the air bag module improperly can accidentally deploy the air bag, which may seriously injure you. Read **SERVICE WARNINGS**, page T1-98, before handling the air bag module.

Warning

- Installing the passenger-side air bag module when a service code 7 is not indicated can accidentally deploy the air bag, which can cause serious injury. Carry out the proper troubleshooting procedures and verify that service code 7 is indicated before installing the passenger-side air bag module.

1. Carry out the "Before Servicing" procedure under **GENERAL PROCEDURES**, page T1-99.
2. Remove the glove compartment cover.
(Refer to section S1.)
3. Remove in the order shown in the figure.
4. Install in the reverse order of removal.
5. Follow the troubleshooting flowchart (page T1-100) to verify that the air bag system is operating normally.

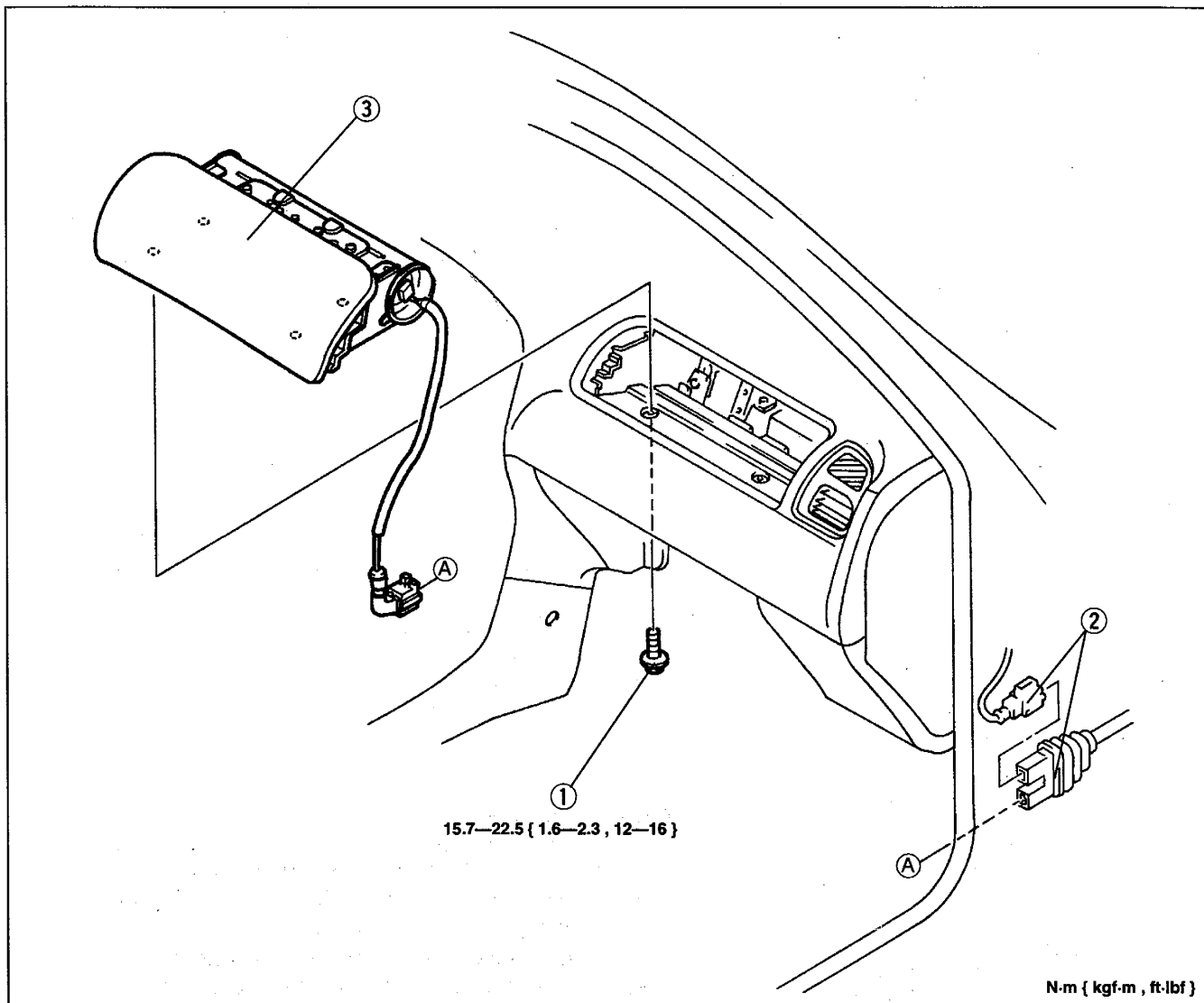

1. Bolt
2. Connectors

3. Passenger-side air bag module

SAS UNIT
Removal / Installation

Warning

- Handling the SAS unit improperly can accidentally deploy the air bags, which may seriously injure you. Read **SERVICE WARNINGS**, page T1-98, before handling the SAS unit.

1. Carry out the "Before Servicing" procedure under **GENERAL PROCEDURES**, page T1-99.
2. Remove the heater unit.
(Refer to section U.)
3. Remove in the order shown in the figure.
4. Install in the reverse order of removal, referring to **Installation note**.
5. Follow the troubleshooting flowchart (page T1-100) to verify that the air bag system is operating normally.

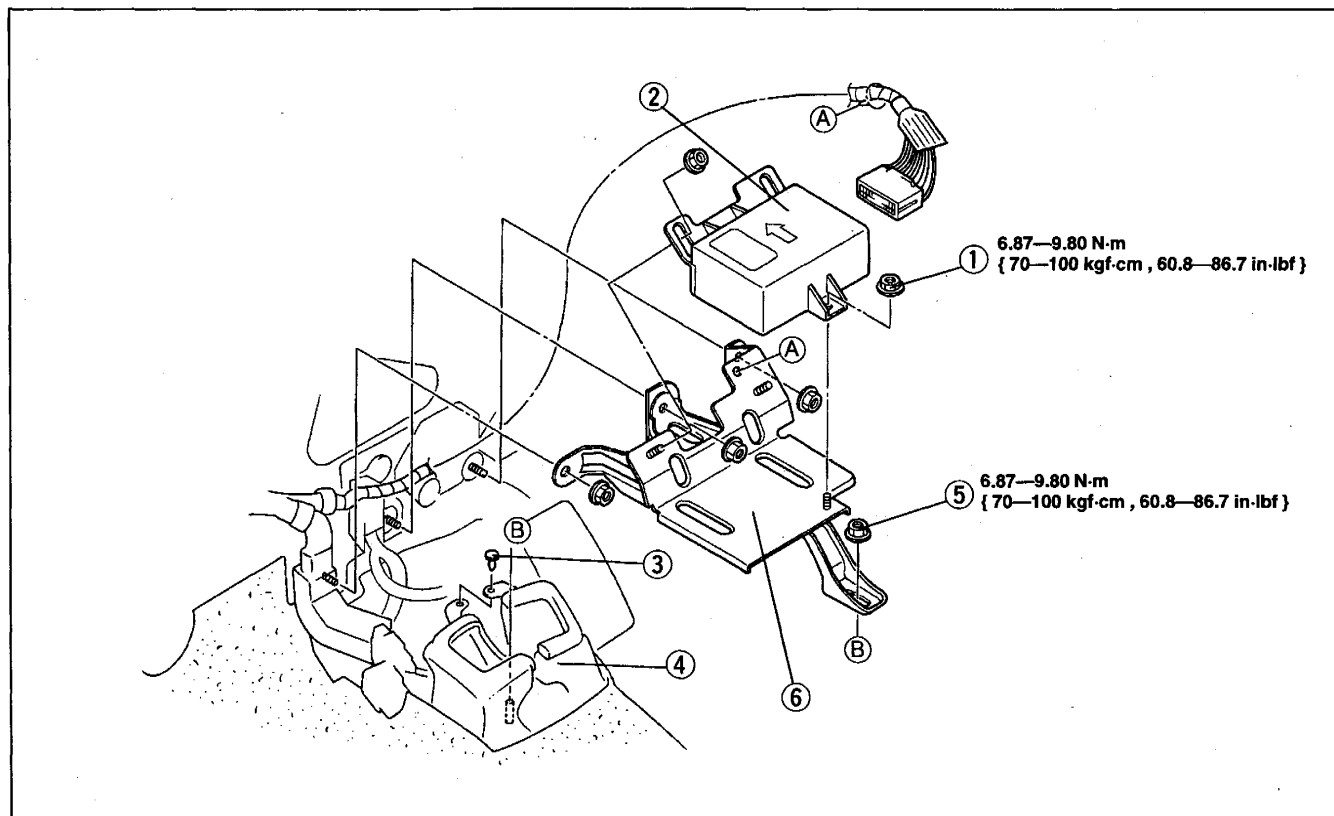

- | | |
|-------------------------------|-------------------------------|
| 1. Nuts | 4. Rear heat duct |
| 2. SAS unit | 5. Nut |
| Installation note below | 6. Bracket |
| 3. Fastener | Installation note below |

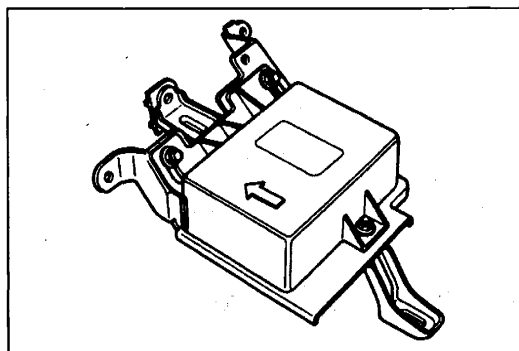

Installation note
SAS unit and bracket

1. Locate the SAS unit and bracket with the arrow on the SAS unit facing toward the front of vehicle. Install them and tighten the nuts to the specified torque.
2. If the mounting area is damaged, carefully repair the area to its original shape before installation.

AIR BAG MODULE DISPOSAL PROCEDURE

Before scrapping a vehicle with an undeployed air bag module, deploy the air bag. Never dispose of a live air bag module. If the **SST** is not available, consult the nearest Mazda representative for assistance.

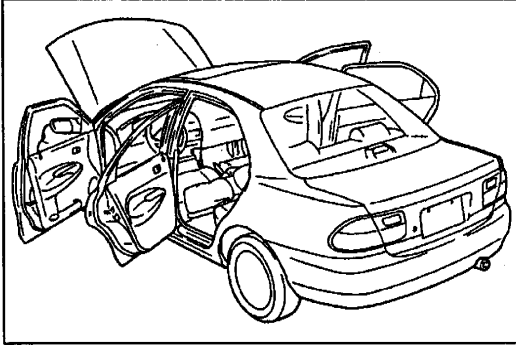
**Air Bag Deployment**

1. Move the vehicle to an open space, away from strong winds, and open all of the vehicle's doors.
2. Disconnect the negative battery cable and wait for more than one minute to allow the backup power supply to deplete its stored power.
3. Follow the appropriate procedure for the driver-side or passenger-side air bag module.

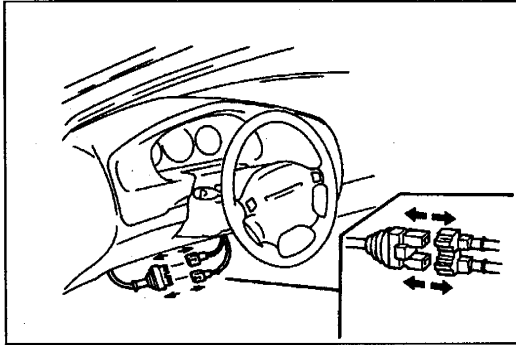
**Driver-side air bag**

- (1) Make sure the air bag module is firmly mounted to the steering wheel.
- (2) Disconnect the orange and blue clock spring connectors.

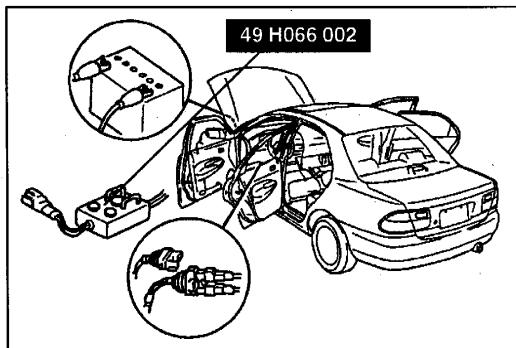

- (3) Inspect the **SST**.
(Refer to page T1-112.)
- (4) Connect the **SST** to the clock spring connector as shown in the figure.

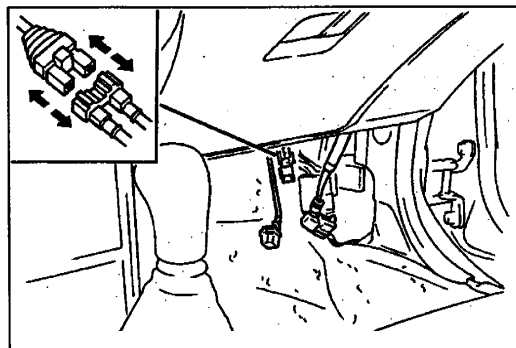
**Passenger-side air bag**

- (1) Make sure the air bag module is firmly mounted to the dashboard.
- (2) Remove the passenger-side scuff plate and front side trim.
(Refer to section S1.)
- (3) Disconnect the orange and blue passenger-side air bag module connector.

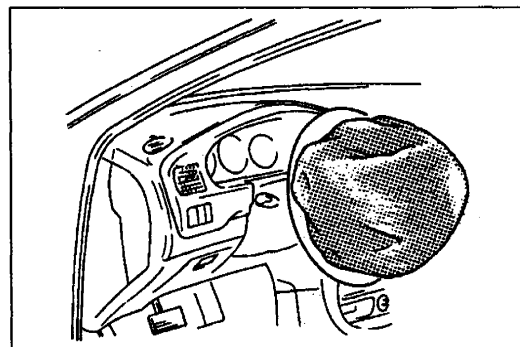
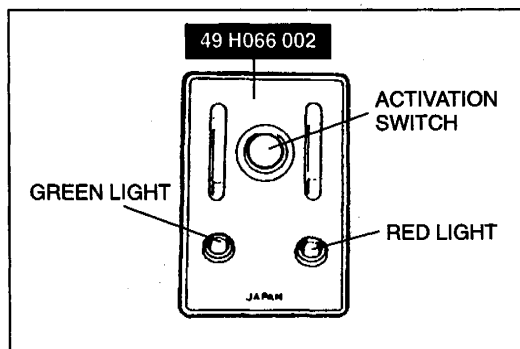
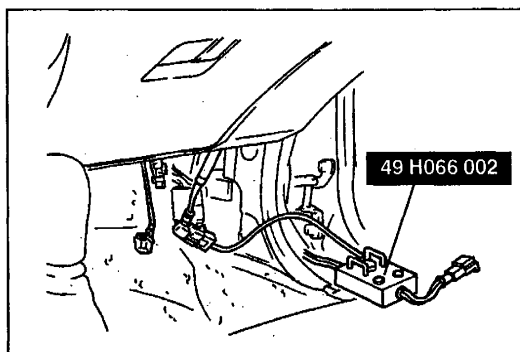

- *(4) Inspect the **SST**.
(Refer to page T1-112.)
- (5) Connect the **SST** to the passenger-side air bag module connector as shown in the figure.

4. Connect the red clip of the **SST** to the positive battery terminal and the black clip to the negative terminal.
5. Verify that the red light on the **SST** is illuminated.
6. Make sure all persons are standing at least 6 m { 20 ft } from the vehicle.
7. Press the activation switch on the **SST** to deploy the air bag.

Air Bag Disposal

Warning

- The air bag is very hot immediately after it deploys. You can be burned. Do not touch the air bag module for at least 15 minutes after deployment.

Warning

- Pouring water on a deployed air bag is dangerous. The water will mix the residual gases to form a gas that can make breathing difficult if inhaled. Do not pour water on the deployed air bag module.

Warning

- A deployed air bag module may contain deposits of sodium hydroxide, a caustic by-product of the gas-generated combustion. If this substance gets in your eyes or on your hands, it can cause irritation and itching. When handling a deployed air bag module, wear gloves and safety glasses.

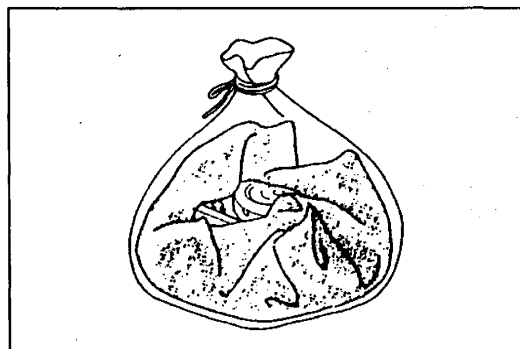

1. Put on gloves and safety glasses.
2. Place the deployed air bag module in a plastic bag, seal it, and then dispose of it.
3. Wash your hands after removing your gloves.

INSPECTION OF SST (DEPLOYMENT TOOL)

- Use the **SST** to deploy a live air bag module before disposing of it.
- Before connecting the **SST** to the clock spring connector or air bag module connector, inspect the operation of the **SST**.

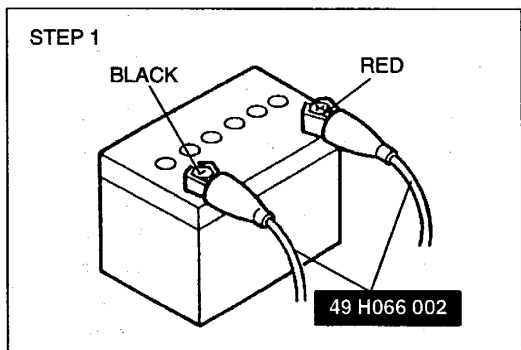
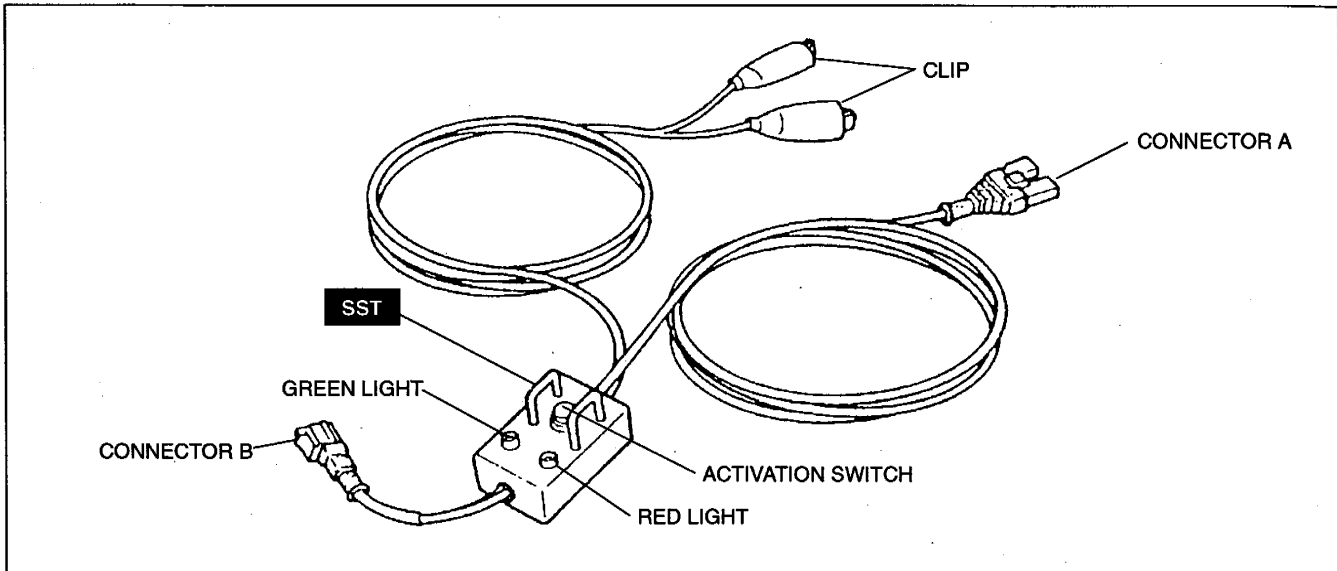

Inspection Procedure

1. Follow the steps below to inspect the operation of the **SST**.

Step	Inspection procedure	Light condition	
		Green	Red
1	Connect red clip to positive battery terminal and black clip to negative battery terminal.	ON	OFF
2	Connect connectors A and B of SST .	OFF	ON
3	Press activation switch.	ON	OFF

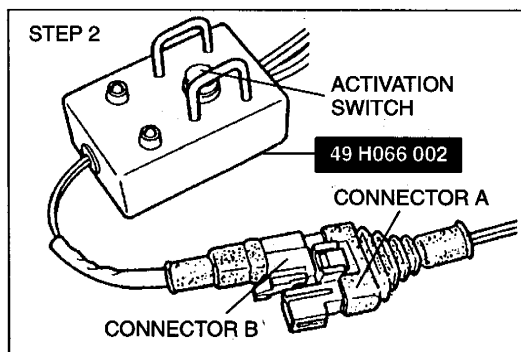

2. If not as specified, do not use the **SST** because it may cause the air bag to unexpectedly deploy upon connection to the harnesses.

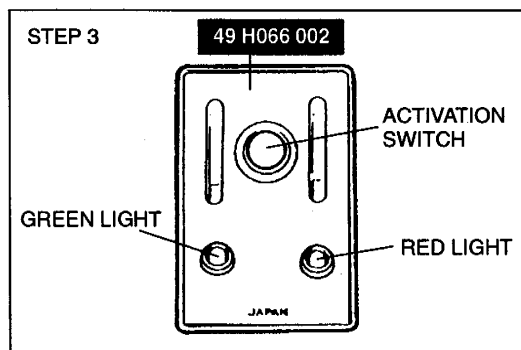

Before beginning any service procedure, refer to section T1 of this manual for air bag system service warnings.

HEATER AND AIR CONDITIONER SYSTEMS

R-134a SYSTEM INTRODUCTION ...	U- 2	RECEIVER/DRIER	U-22
OUTLINE	U- 2	REFRIGERANT LINES	U-23
SERVICE WARNINGS	U- 3	REAR HEAT DUCT	U-25
SERVICE CAUTIONS	U- 4	CONTROL SYSTEM	U-26
REFRIGERANT SYSTEM SERVICE		PREPARATION	U-26
PROCEDURES	U- 5	STRUCTURAL VIEW	U-26
CHARGING PROCEDURE FLOW ..	U- 5	MAGNETIC CLUTCH	U-27
MANIFOLD GAUGE SET		CONDENSER FAN	U-30
INSTALLATION	U- 5	REFRIGERANT PRESSURE	
CHARGING	U- 6	SWITCH	U-31
GAS LEAK TEST	U- 8	RELAY	U-31
REFRIGERANT CHARGE CHECK ..	U- 9	BLOWER MOTOR	U-32
REFRIGERANT PRESSURE		RESISTOR	U-32
CHECK	U- 9	AIR INTAKE ACTUATOR	U-33
PERFORMANCE TEST	U-10	AIRFLOW MODE ACTUATOR	U-33
BASIC SYSTEM	U-11	THERMOSWITCH	U-34
STRUCTURAL VIEW	U-11	A/C AMPLIFIER	U-34
BLOWER UNIT	U-12	HEATER CONTROL UNIT	U-36
HEATER UNIT	U-14	TROUBLESHOOTING	U-44
COOLING UNIT	U-17	TROUBLESHOOTING NOTES	U-44
A/C COMPRESSOR	U-20	USING THIS SECTION	U-44
CONDENSER	U-21	TROUBLESHOOTING	U-47

R-134a SYSTEM INTRODUCTION

OUTLINE

- R-12 and other fluorocarbons now used in air conditioners can destroy the ozone layer in the stratosphere. The result is an increase in hazardous ultraviolet rays which over time can adversely affect both human health and the biosphere. Because of this concern, Mazda has chosen to use R-134a (HFC-134a), a hydrofluorocarbon-based refrigerant that does not deplete the ozone layer, in this vehicle.
- R-12 and R-134a are not interchangeable; system parts and system service tools also differ. The table below compares the two systems. (Maintenance-related items only)

Refrigerant Systems

Part	R-12 system	R-134a system	Remarks
Refrigerant	Chlorofluorocarbon-12 (CFC-12) (CCl ₂ F ₂)	Hydrofluorocarbon-134a (HFC-134a) (CH ₂ FCF ₃)	If the refrigerants are mixed or one refrigerant is used in a system that requires the other, the compressor oil will separate from the refrigerant and not circulate within the system. This can damage the A/C compressor. In addition, mixing R-134a with R-12 or using R-134a instead of R-12 in an R-12 system can lower the durability of the NBR O-ring and dissolve the fluorine rubber O-rings. If the fluorine rubber O-rings are dissolved, refrigerant may leak.
Compressor oil	Mineral oil	Polyalkylene glycol oil (PAG oil) [SP10]	Special compressor oils for R-134a air conditioning systems are developed by each air conditioning vendor. Therefore, use only the specified oil for each model vehicle. If a PAG oil other than the specified type is used, the A/C compressor and refrigerant system can be damaged. If the compressor oils are mixed or one compressor oil is used in a system that requires the other, the refrigerant will separate from the compressor oil and not circulate within the system. This can damage the A/C compressor. Mixing PAG oil with mineral oil or using PAG oil instead of mineral oil in an R-12 system can lower the durability of the NBR and fluorine rubber O-rings.
O-ring	Nitrile butadiene rubber (NBR) Fluorine rubber	High-circulated nitrile butadiene rubber (HNBR)	If an NBR O-ring is used in an R-134a system, the PAG oil and R-134a will lower the durability of the O-ring. If a fluorine rubber O-ring is used in an R-134a system, the R-134a will dissolve the O-ring and cause the refrigerant to leak.
Joint nuts	Inch threads	Metric threads	Thread standards for joint nuts connecting cooler pipes and hoses have been changed to avoid connecting R-12 system parts with R-134a system parts.
Joint blocks	—	—	The bolt sizes and part measurements for joint blocks connecting cooler pipes and cooler hoses have been changed to avoid connecting R-12 system parts with R-134a system parts.
Charging valve	Screw-on type HI: 3/8—24 UNF LO: 7/16—20 UNF	Quick-connect type HI: 16 mm { 0.6 in } dia. LO: 13 mm { 0.5 in } dia.	The shape of the charging valve differs for each system to avoid confusion. The quick-connect type charging valve prevents refrigerant from leaking when the charging hose is connected to the valve.

Service Tools

Part	R-12 system	R-134a system	Remarks
Tool joints	Inch threads	Metric threads	Thread standards for tool joints have been changed to avoid connecting R-12 system tools with R-134a system tools.
Charging valve joints	Screw-on type HI: 3/8—24 UNF LO: 7/16—20 UNF	Quick-connect type HI: 16 mm { 0.6 in } dia. LO: 13 mm { 0.5 in } dia.	The shape of the charging valve joints differ for each system to avoid confusion. The quick-connect type charging valve joint prevents refrigerant from leaking when the charging hose is connected to the valve.
Manifold gauge	High-pressure-side maximum reading: 2.9 MPa { 30 kgf/cm ² , 430 psi }	High-pressure-side maximum reading: 3.5 MPa { 35 kgf/cm ² , 500 psi }	R-134a requires a higher pressure to condense than R-12.
Gas leak tester	Gas type Electric type	Electric type	A gas leak tester reacts with chlorine in R-12 to indicate the location of a leak. This kind of tester does not work with an R-134a system, however, because R-134a has no chlorine. Two kinds of electric testers are available: those that work exclusively with one system or the other, and those that work with both. A tester built only for R-12 systems cannot be used with an R-134a system.

SERVICE WARNINGS

Using/Handling Unapproved Refrigerant

- * Using a flammable refrigerant, such as OZ-12, in this vehicle is dangerous. In an accident, the refrigerant may catch fire, resulting in serious injury or death. When servicing this vehicle, use only R-134a.
- * Checking for system leaks on a vehicle that has been serviced with flammable refrigerant, such as OZ-12, is dangerous. Conventional leak detectors use an electronically generated arc which can ignite the refrigerant, causing serious injury or death. If a flammable refrigerant may have been used to service the system, or if you suspect a flammable refrigerant has been used, contact the local fire marshall or EPA office for information on handling the refrigerant.

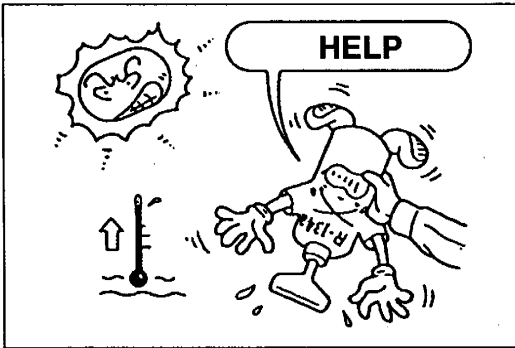

Servicing Refrigerant System

- Do not allow the refrigerant to leak near fire or any kind of heat. A poisonous gas may be generated if the refrigerant gas contacts fire or heat such as from cigarettes and heaters. When carrying out any operation that can cause refrigerant leakage, extinguish or remove the above-mentioned heat sources and maintain adequate ventilation.

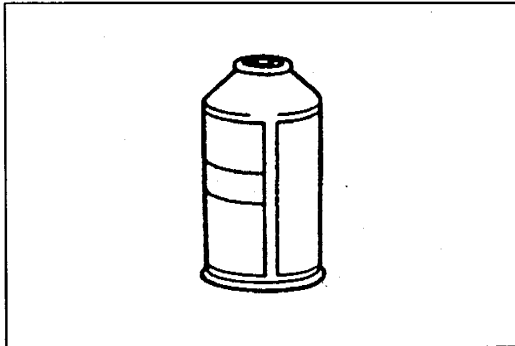

Storing Refrigerant

- The refrigerant container is highly pressurized. If it is subjected to high heat, it could explode, scattering metal fragments and liquid refrigerant that can seriously injure you. Store the refrigerant at temperatures below 40 °C { 104 °F }.

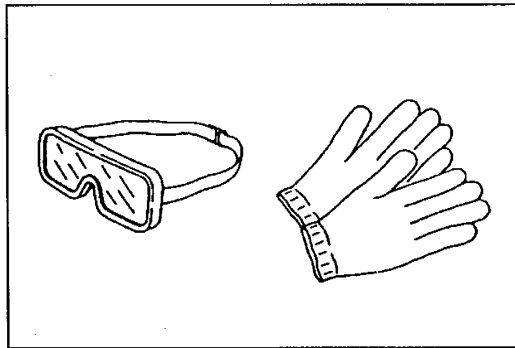

Handling Refrigerant

- Handling liquid refrigerant is dangerous. A drop of it on the skin can result in localized frostbite. When handling the refrigerant, wear gloves and safety goggles. If refrigerant splashes into the eyes, immediately wash them with clean water and consult a doctor.

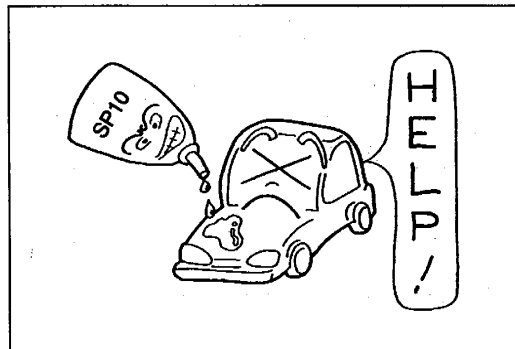

SERVICE CAUTIONS

Compressor Oil (SP10)

- Do not spill compressor oil on the vehicle. A drop of compressor oil on the vehicle surface can eat away at the paint. If oil gets on the vehicle, wipe it off immediately.

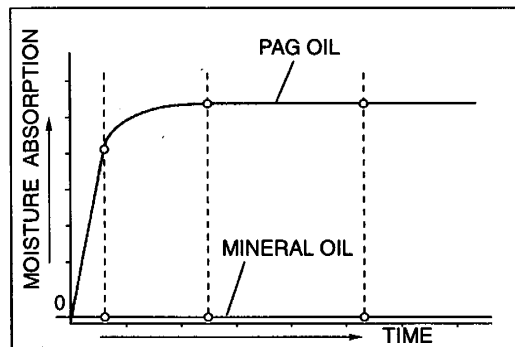

- PAG oil has a higher moisture absorption efficiency than the previously used mineral oil. If moisture mixes with the compressor oil, the refrigerant system could be damaged. Therefore, install caps immediately after using the compressor oil or removing refrigerant system parts to prevent moisture absorption.

REFRIGERANT SYSTEM SERVICE PROCEDURES

CHARGING PROCEDURE FLOW

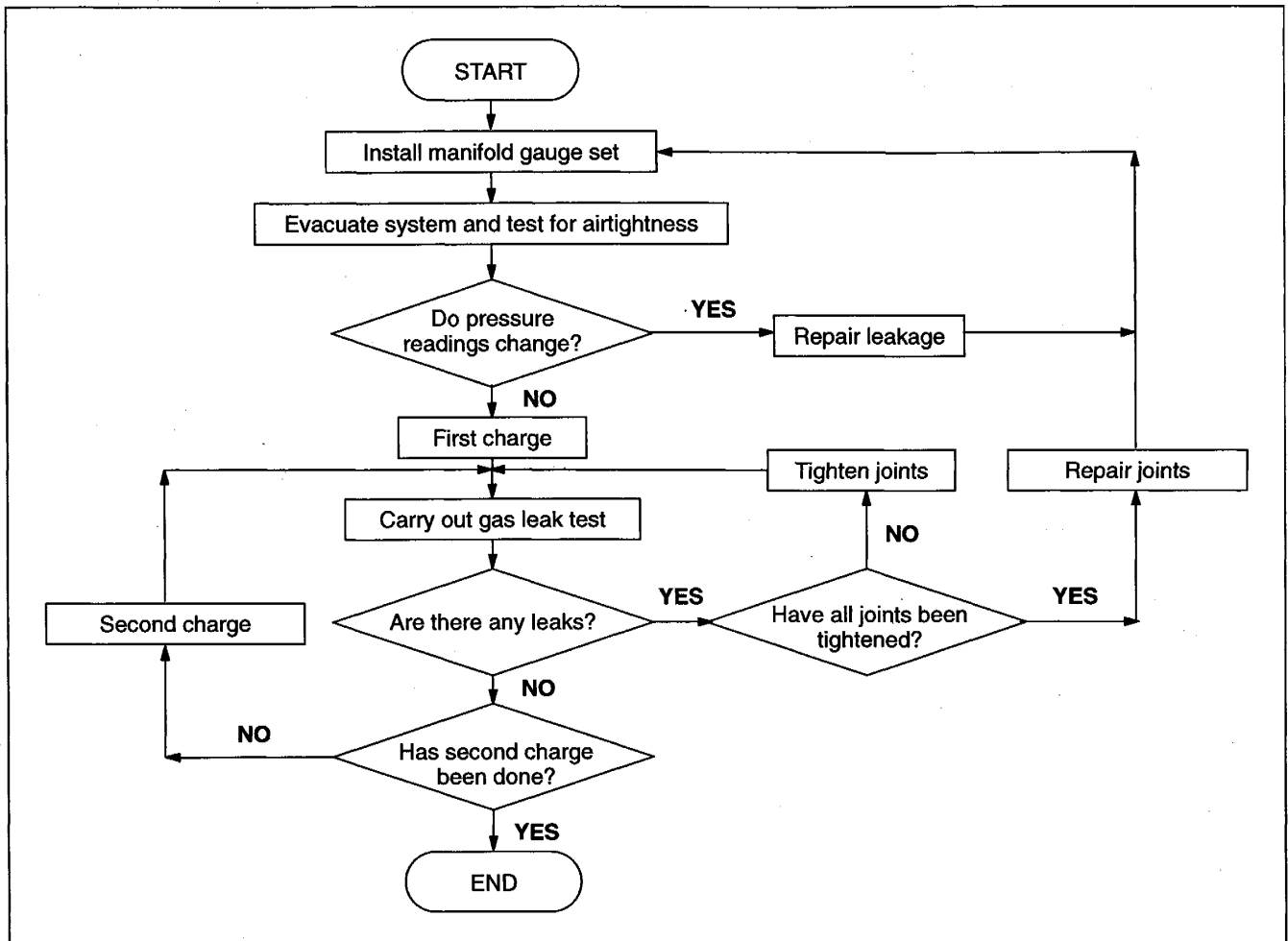

U

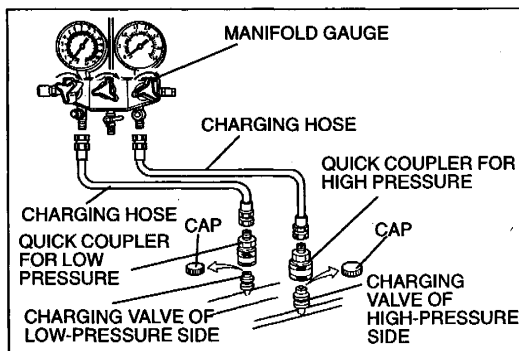

MANIFOLD GAUGE SET INSTALLATION

1. Fully close the valves of the manifold gauge.
2. Connect charging hoses to the high- and low-pressure side joints of the manifold gauge.
3. Connect quick couplers to the ends of the charging hoses.
4. Remove the caps from the high- and low-pressure side charging valves.
5. Connect the quick couplers to the charging valves.

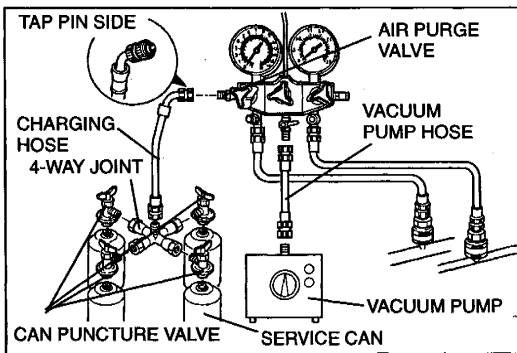
**CHARGING**

1. Install the manifold gauge set. (Refer to page U-5.)
 2. Connect the tap pin side of the charging hose to the air purge valve of the manifold gauge.
 3. Connect the vacuum pump hose to the center joint of the manifold gauge.
 4. Connect the vacuum pump hose to the vacuum pump.
 5. Connect can puncture valves to a 4-way joint.
 6. Fully open the can puncture valves and connect service cans to the valves.
- Regular amount of refrigerant: 600 g { 21.2 oz }**
7. Fully close any can puncture valve that is not connected to a service can.
 8. Connect the 4-way joint to the charging hose that is connected to the gauge set air purge valve.
9. Open all the valves of the manifold gauge.
 10. Start the vacuum pump and let it operate for **15 minutes**.

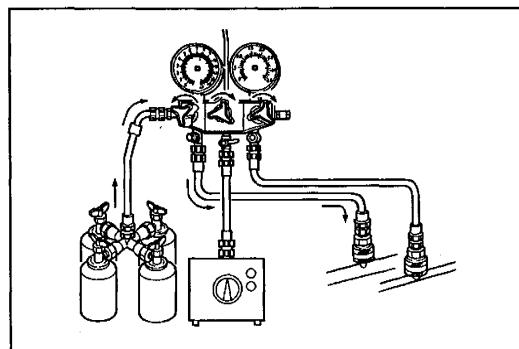
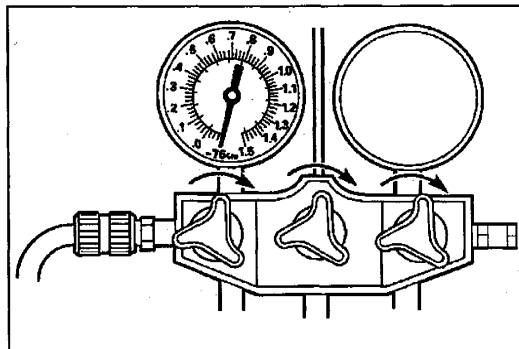
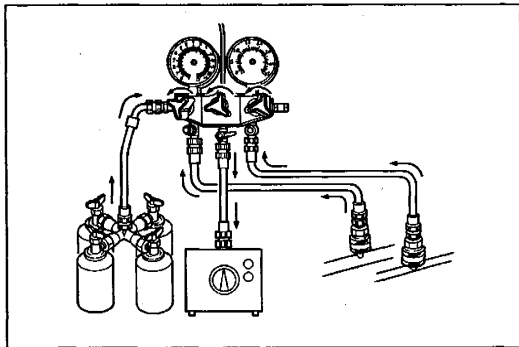

11. After 15 minutes, verify that the high- and low-pressure-side readings of the manifold gauge are at **-101 kPa { -760 mmHg , -29.9 inHg }** . Close each valve of the manifold gauge.
 12. Stop the vacuum pump and wait for about **5 minutes**.
 13. After 5 minutes, check the low-pressure-side reading of the manifold gauge. If the reading has changed, check for leaks and then repeat from step 9. If reading has not changed, go to step 14.
14. Open the service cans by using the can puncture valves.
 15. Open the low-pressure side valve of the manifold gauge and charge with refrigerant until the low-pressure-side reading is at **100 kPa { 1 kgf/cm² , 10 psi }** .

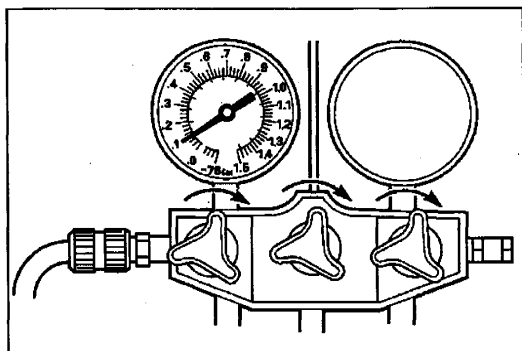

16. Close the low-pressure side valve of the manifold gauge.
17. Check for leaks by using a gas leak tester. If there are no leaks, go to step 18. If a leak is found at a loose joint, tighten the joint and check for leaks again. If there is still a leak at the same joint, discharge the refrigerant and then repair the joint. Repeat the charging procedure from step 9. If there are no leaks after tightening the joint, go to step 18.

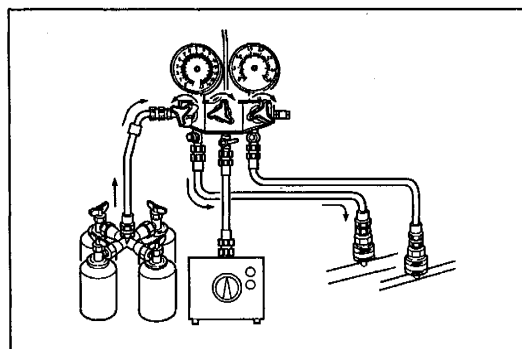

18. Open the low-pressure side valve of the manifold gauge and charge with half the regular amount of refrigerant.

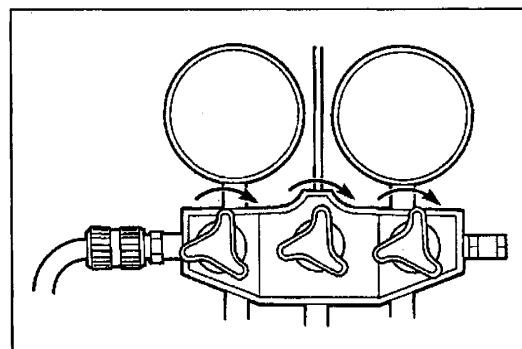

19. Close the low-pressure side valve of the manifold gauge.

Warning

- **Running the engine with the high-pressure side valve open is dangerous. Pressure within the service cans will increase and the cans could explode, scattering metal fragments and liquid refrigerant that can seriously injure you. Therefore, do not open the high-pressure side valve while the engine is running.**

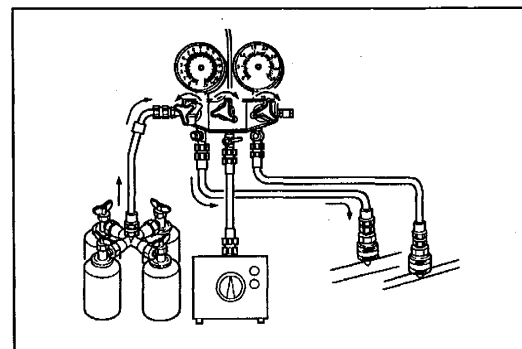

20. Start the engine and actuate the A/C compressor.
21. Open the low-pressure side valve of the gauge set and charge with the remaining refrigerant.
22. Close the low-pressure side valve of the manifold gauge.
23. Stop the engine and A/C compressor.
24. Check for leaks by using a gas leak tester. If there are no leaks, go to step 25. If a leak is found at a loose joint, tighten the joint and check for leaks again. If there is still a leak at the same joint, discharge the refrigerant and then repair the joint. Repeat the charging procedure from step 9. If there are no leaks after tightening the joint, go to step 25.
25. Disconnect the high- and low-pressure-side quick couplers from the charging valves.
26. Install the caps to the charging valves.

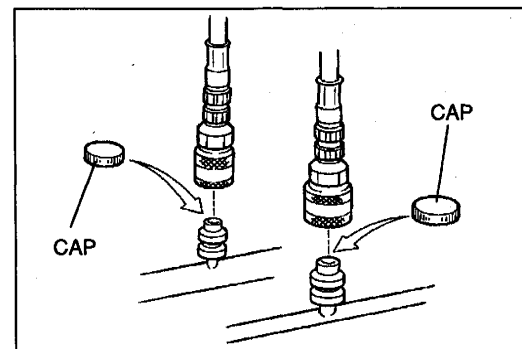

GAS LEAK TEST

Warning

- Improperly handling flammable substances is dangerous. It could result in injury or death. Before checking for gas leakage, read the "SERVICE WARNINGS". (Refer to page U-3.)

1. Check for oil stains on the connections shown below.
2. If there is no oil stain, go to step 4.
3. If there is an oil stain, check for a loose connection. If it's loose, tighten the connection to the specified torque and refill the oil and recharge the refrigerant. (Refer to page U-6.) If the connection is properly tightened, replace the O-ring and, if necessary, other parts. Refill the oil and recharge the refrigerant. (Refer to page U-6.)
4. Check for leaks at the connections by using the gas leak tester.
5. If there is leakage, check for a loose connection. If it's loose, tighten the connection to the specified torque and refill the oil and recharge the refrigerant. (Refer to page U-6.) If the connection is properly tightened, replace the O-ring and, if necessary, other parts. Refill the oil and recharge the refrigerant. (Refer to page U-6.)

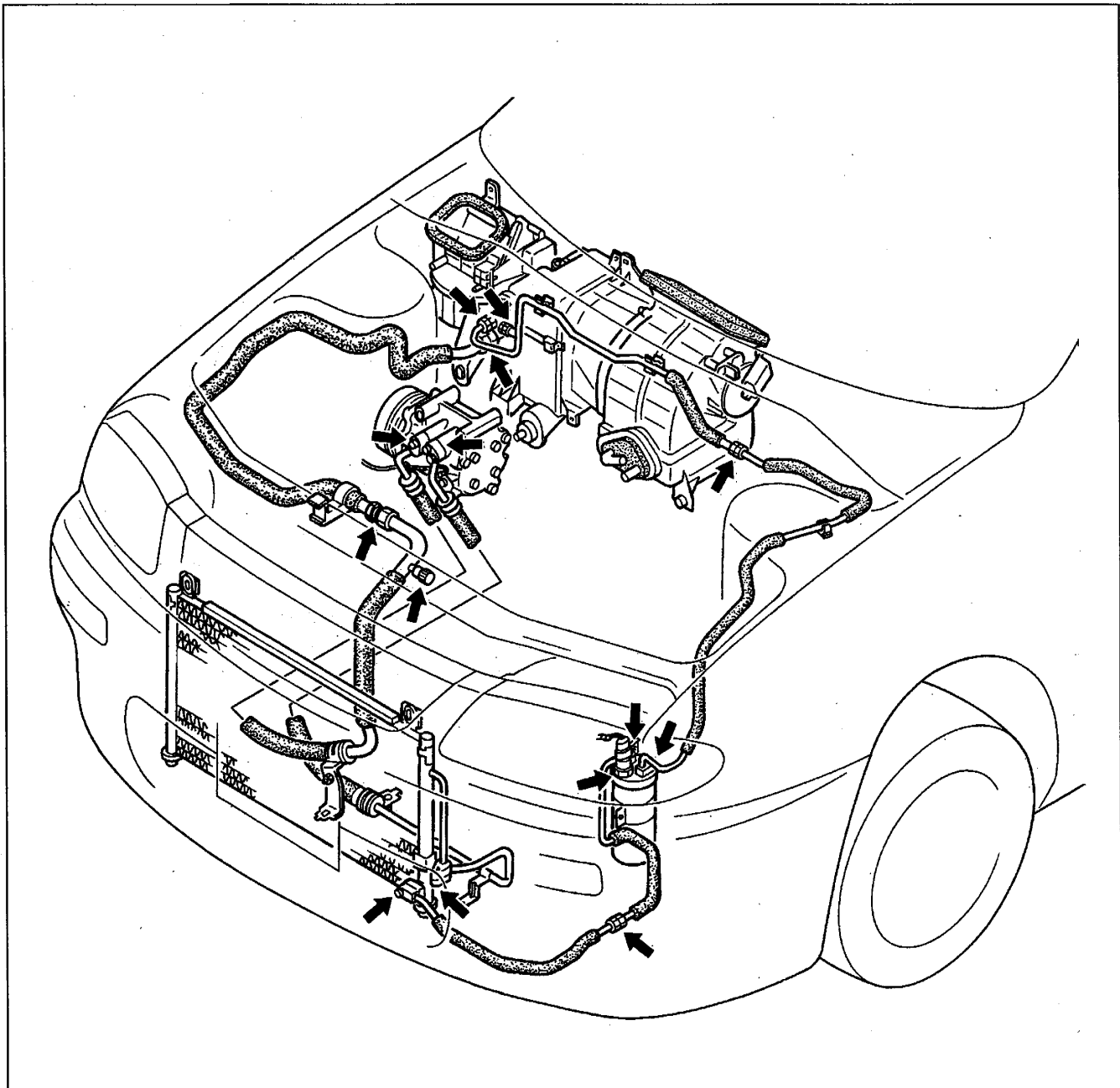

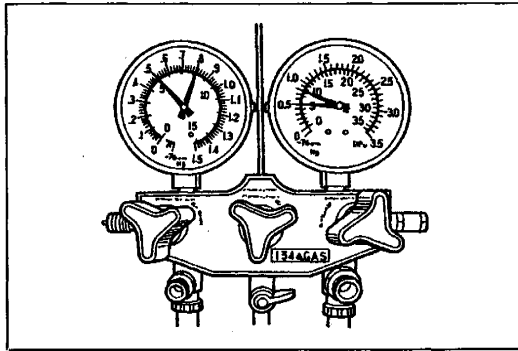

REFRIGERANT CHARGE CHECK

1. Install the manifold gauge set. (Refer to page U-5.)
2. Check the refrigerant pressure reading with the engine stopped.
3. Verify that the high- and low-pressure-side readings of the manifold gauge are at **493—788 kPa { 5.02—8.04 kgf/cm² , 72—114 psi }**. If the pressure readings are lower than specified, recharge the refrigerant. (Refer to page U-6.) If the pressure readings are within specification but there is insufficient cooling, go to the next step. If the pressure readings are within specification and there are no leaks, the refrigerant amount is OK.
4. Start the engine and run it at a constant **2,000 rpm**.
5. Turn the A/C switch on, set the fan switch at MAX-HI, and set the air intake mode at REC.
6. If the A/C compressor is short-cycling, note the low-pressure-side reading at which the magnetic clutch kicks out.
7. If the pressure is **170 kPa { 1.7 kgf/cm² , 24 psi }** or lower, evacuate and recharge the refrigerant system with the proper amount of refrigerant. (Refer to page U-6.) If the pressure is **210 kPa { 2.1 kgf/cm² , 30 psi }** or higher, inspect the thermostat. (Refer to page U-34.)

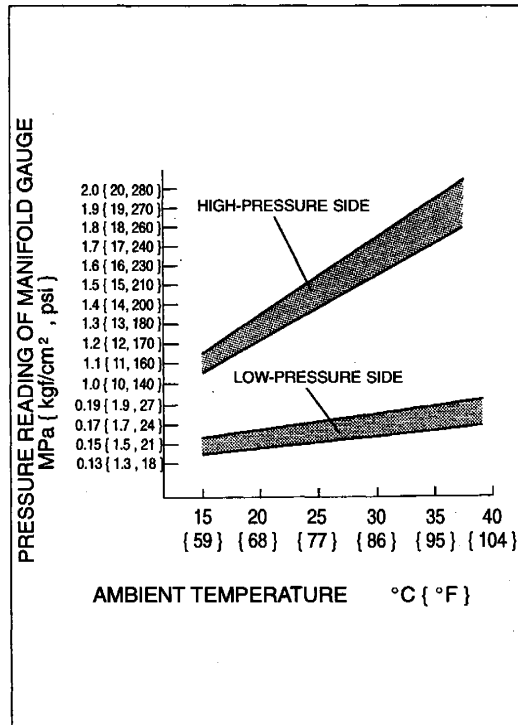

REFRIGERANT PRESSURE CHECK

1. Install the manifold gauge set. (Refer to page U-5.)
2. Close the front doors and the front windows.
3. Warm up the engine and run it at a constant **1,500 rpm**.
4. Set the fan switch at the 4th position.
5. Turn the A/C switch on.
6. Set the REC/FRESH lever to RECIRCULATE. (wire type)
7. Turn the REC switch on. (logic type)
8. Set the mode lever to VENT. (wire type)
9. Turn the VENT switch on. (logic type)
10. Set the temperature control lever to MAX COLD.
11. Measure the ambient temperature and the high- and low-pressure-side readings of manifold gauge.
12. If the high- and low-pressure-side readings are in the shaded zones shown in the figure, refrigerant system is normal. If the readings are abnormal, refer to flowchart No.13 and troubleshoot the system. (Refer to page U-59.)

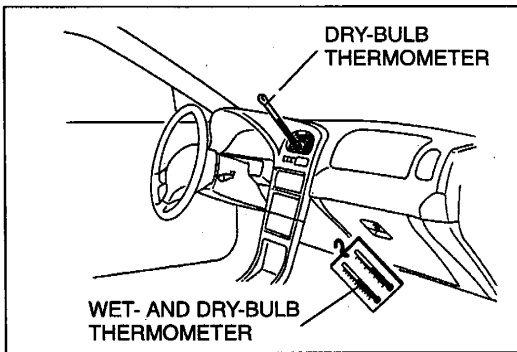

PERFORMANCE TEST

After servicing the refrigerant system, test its performance.

1. Install the manifold gauge set. (Refer to page U-5.)
2. Place a dry-bulb thermometer in the center ventilator outlet.
3. Place a wet- and dry-bulb thermometer at the blower inlet.
4. Open the all doors and the all windows.
5. Warm up the engine and run it at constant **1,500 rpm**.
6. Turn the A/C switch on.
7. Set the fan switch at the 4th position.
8. Set the REC/FRESH lever to RECIRCULATE. (wire type)
9. Turn the REC switch on. (logic type)
10. Set the mode lever to VENT. (wire type)
11. Turn the VENT switch on. (logic type)
12. Set the temperature control lever to MAX COLD.
13. Wait until the air conditioner output temperature stabilizes.

Stabilized condition

Blower inlet temperature: 25—35 °C { 77—95 °F }

High-pressure-side reading:

1.3—1.6 MPa { 13—17 kgf/cm² , 190—240 psi }

14. After the air conditioning stabilizes, read the wet- and dry-bulb thermometer, and then calculate the relative humidity by using the graph below.

HOW TO READ THE GRAPH :

After measuring the temperatures of wet- and dry-bulb thermometer at the blower inlet, relative humidity (%) can be obtained.

Example; Supposing dry- and wet-bulb temperatures at the blower inlet are 25 °C { 77 °F } and 19.5 °C { 67.1 °F }, respectively, the point of intersection of the dotted lines in the graph is 60%.

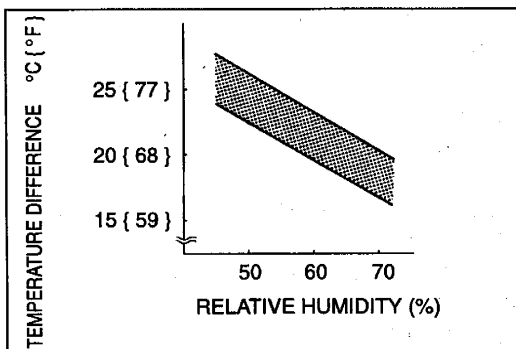
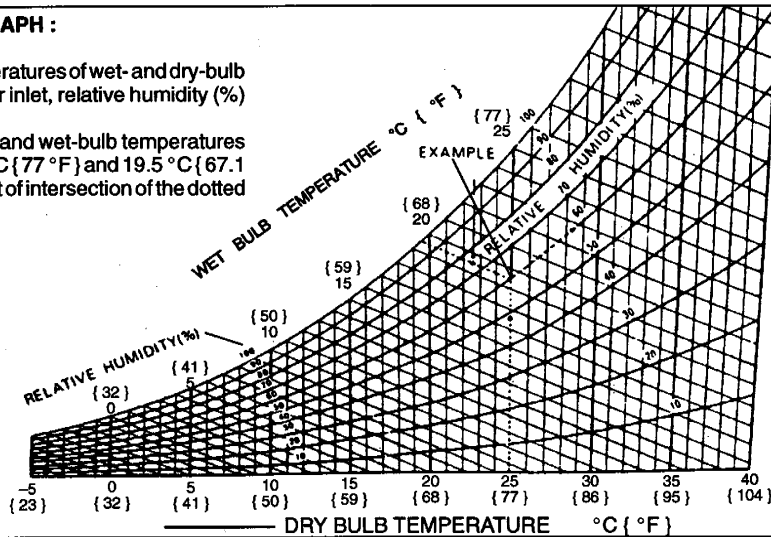

15. Read the dry-bulb thermometer at the air outlet, and calculate the temperature difference between the center ventilator outlet and the blower inlet.
16. Verify that the intersection of the temperature difference and the relative humidity is in the shaded zone.
17. If the performance is abnormal, troubleshoot the system. (Refer to page U-47.)

BASIC SYSTEM

STRUCTURAL VIEW

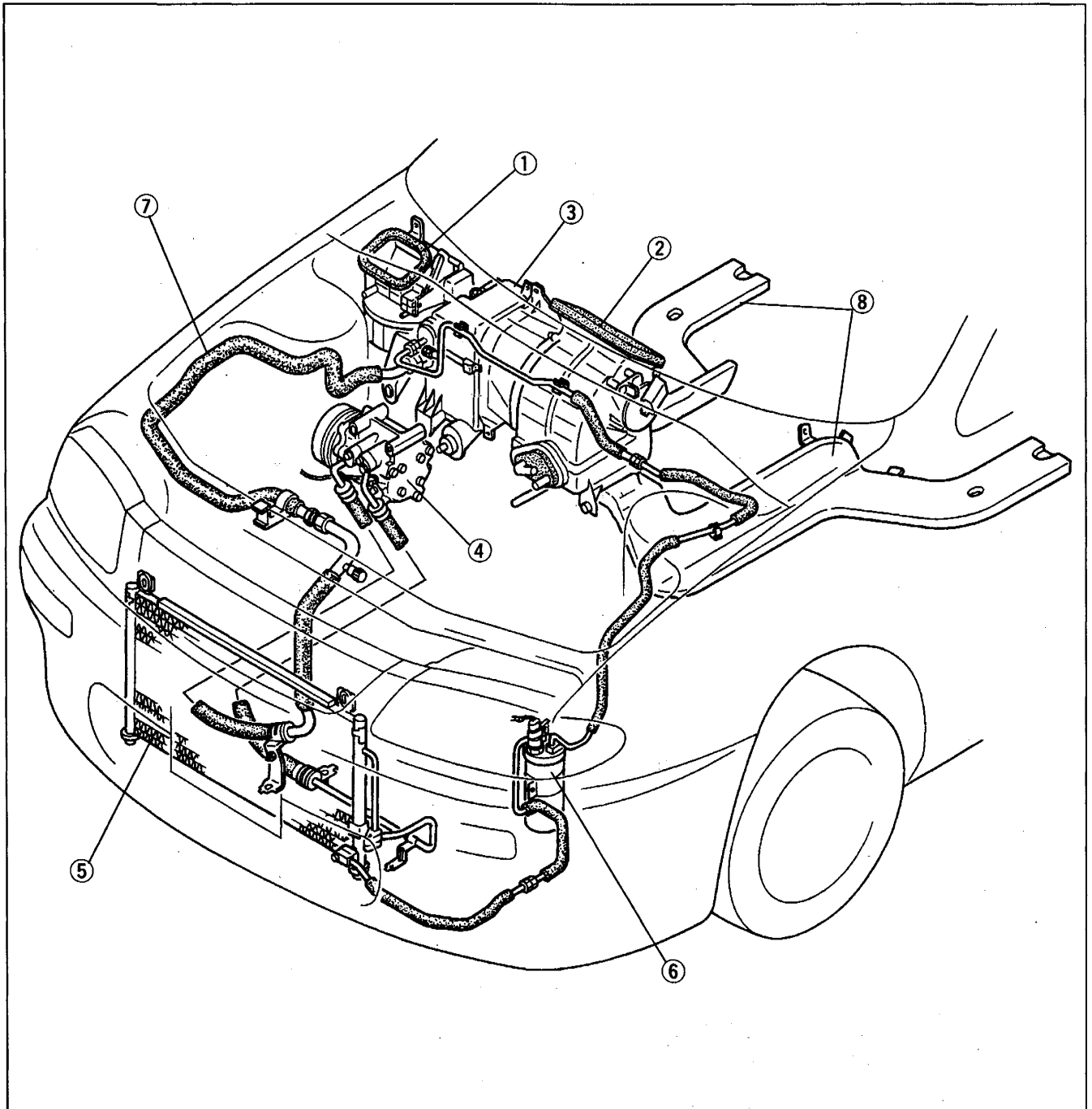

- 1. Blower unit
Removal / Installation page U-12
Disassembly / Assembly .. page U-13
- 2. Heater unit
Removal / Installation page U-14
Disassembly / Assembly .. page U-15
Inspection page U-16
- 3. Cooling unit
Removal / Installation page U-17
Disassembly / Assembly .. page U-18
Inspection page U-19

- 4. A/C compressor
Removal / Installation page U-20
- 5. Condenser
Removal / Installation page U-21
Inspection page U-21
- 6. Receiver/drier
Removal / Installation page U-22
- 7. Refrigerant lines
Removal / Installation page U-23
- 8. Rear heat duct
Removal / Installation page U-25

BLOWER UNIT

Removal / Installation

1. Remove the dashboard. (Refer to section S1.)
2. Remove the cooling unit. (Refer to page U-17.)
3. Remove in the order shown in the figure.
4. Install in the reverse order of removal.

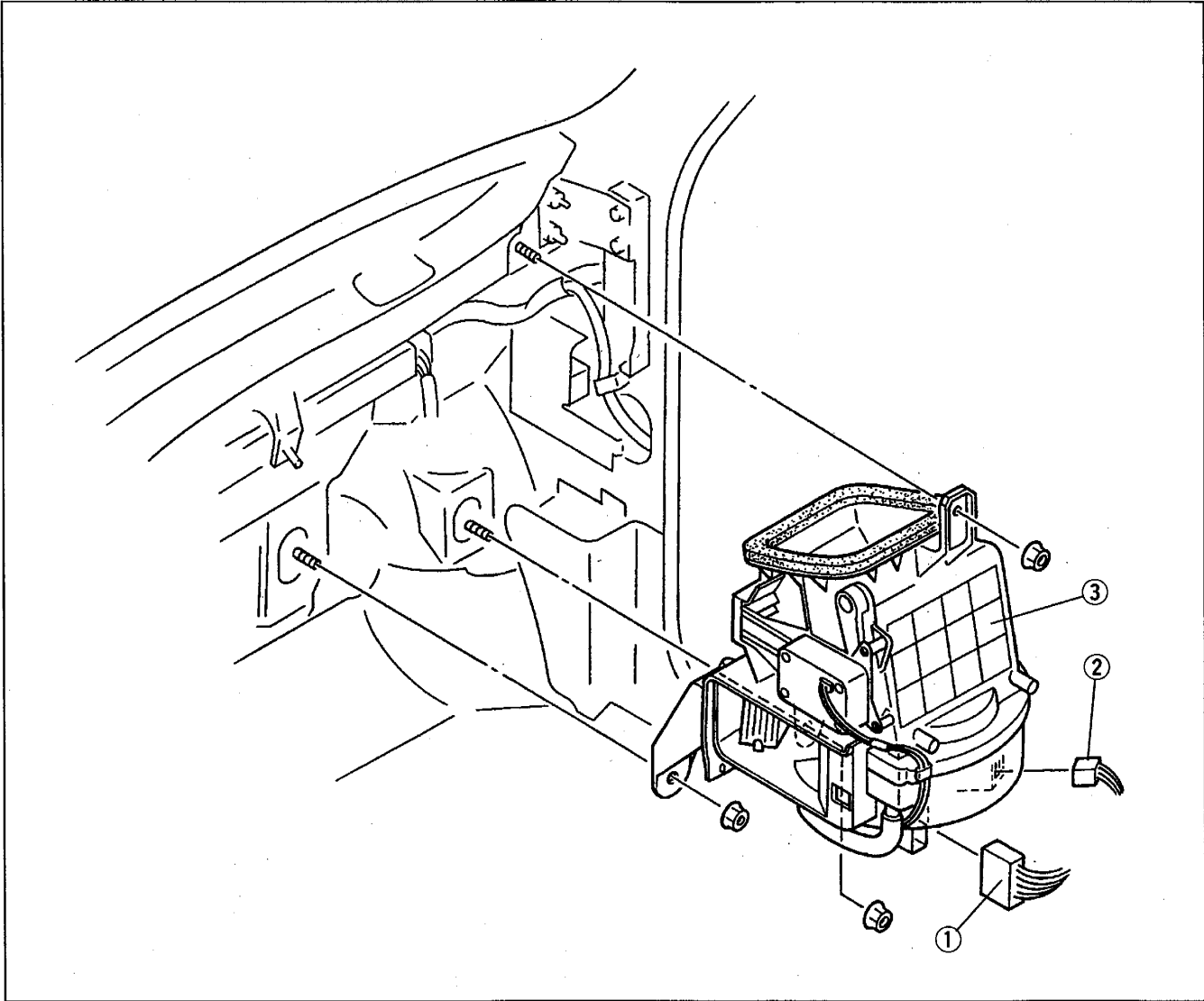

1. Blower unit connector
2. Blower motor connector

3. Blower unit
Disassembly / Assembly page U-13

Disassembly / Assembly

1. Disassemble in the order shown in the figure.
2. Assemble in the reverse order of disassembly.

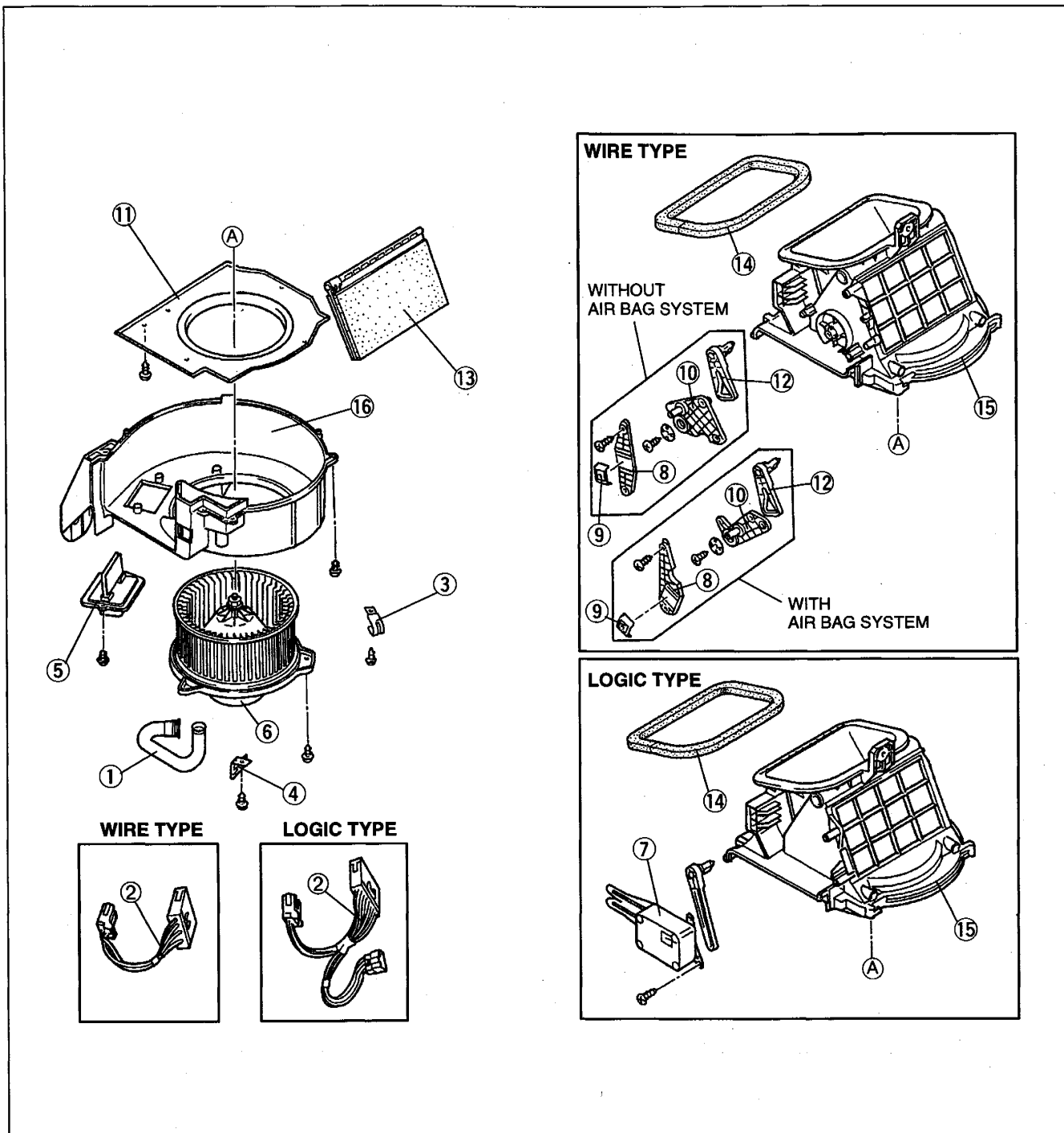

1. Air hose
2. Blower harness
3. Harness clip
4. Connector bracket
5. Resistor
6. Blower motor
7. Air intake actuator
8. Wire clamp bracket

9. Wire clamp
10. Air intake link
11. Air guider
12. Air intake crank
13. Air intake door
14. Polyurethane protector
15. Blower case (top)
16. Blower case (bottom)

HEATER UNIT

Removal / Installation

1. Drain the engine coolant. (Refer to section E.)
2. Remove the dashboard. (Refer to section S1.)
3. Remove the cooling unit. (Refer to page U-17.)
4. Remove in the order shown in the figure.
5. Install in the reverse order of removal.

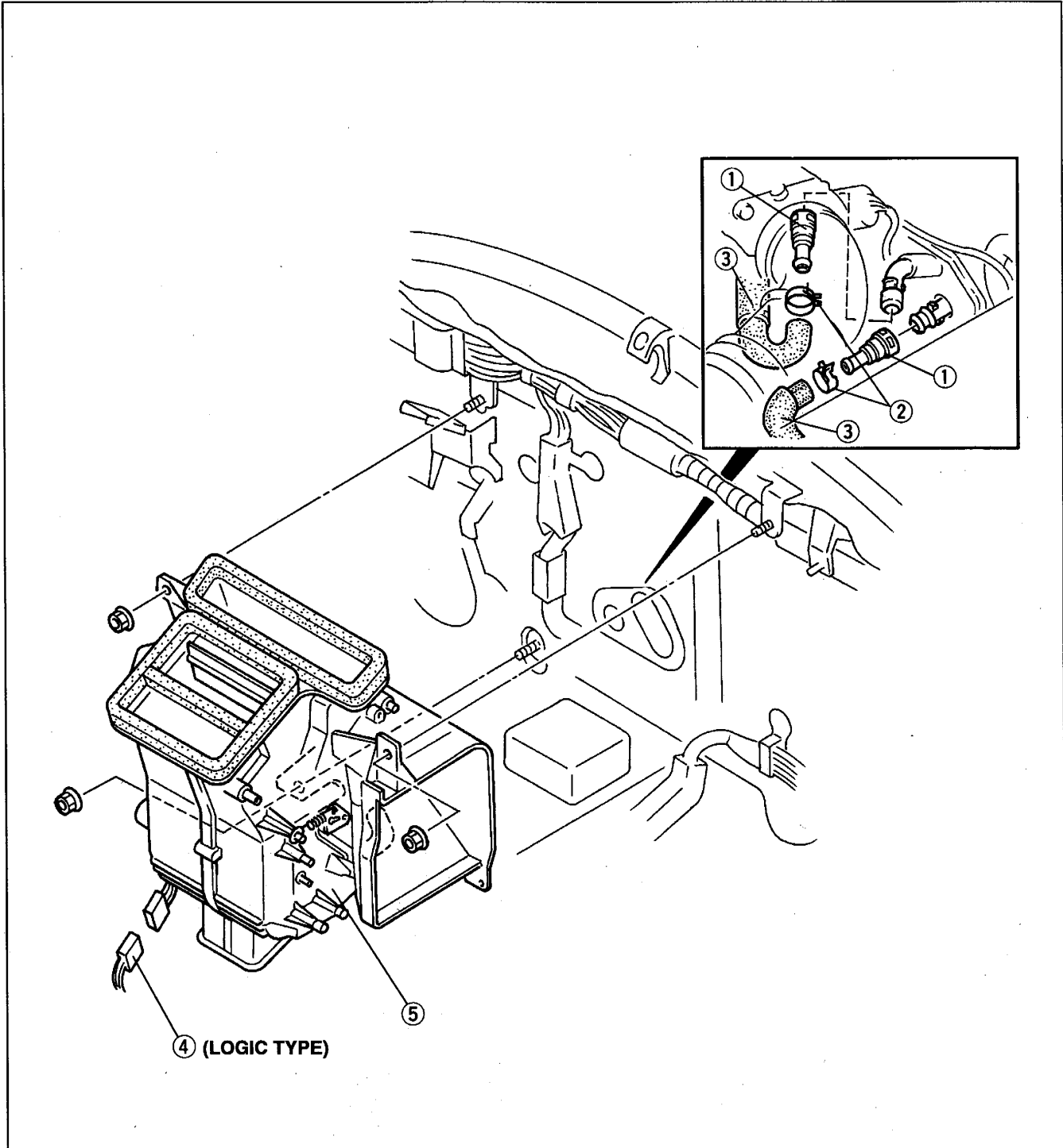

1. Quick connector
2. Hose clamp
3. Heater hose
4. Heater unit connector

5. Heater unit
 Disassembly / Assembly page U-15
 Inspection page U-16

Disassembly / Assembly

1. Disassemble in the order shown in the figure.
2. Assemble in the reverse order of disassembly, referring to **Assembly note**. Do not apply extra grease to the links.

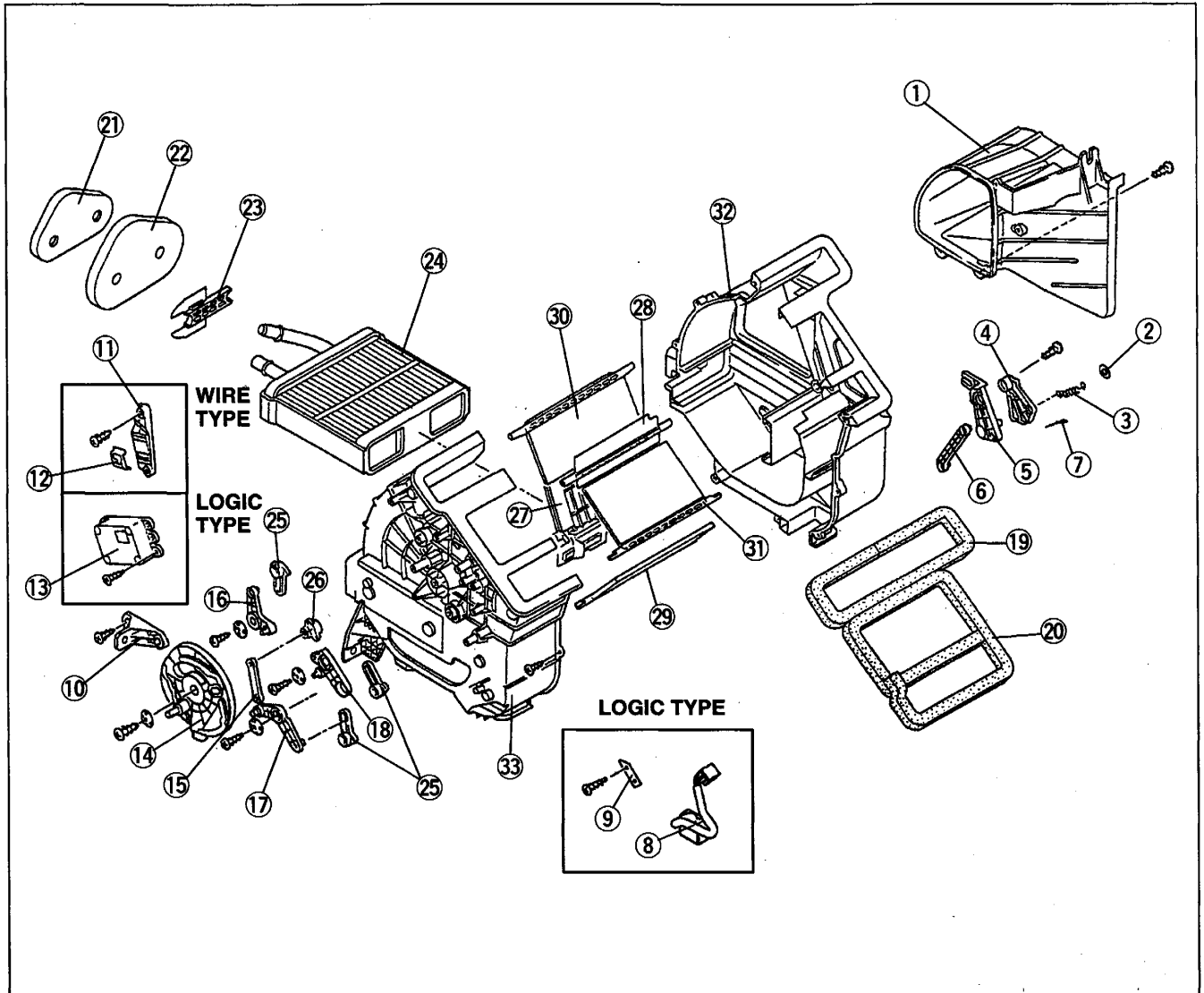

- | | |
|--|--|
| <ol style="list-style-type: none"> 1. Duct 2. Push nut 3. Spring 4. Air mix crank 5. Air mix link 6. Air mix rod 7. Air mix wire clamp 8. Heater harness 9. Connector bracket 10. Heater unit bracket 11. Wire clamp bracket 12. Airflow mode wire clamp 13. Airflow mode actuator 14. Airflow mode main link 15. Airflow mode rod 16. Airflow mode sub link (DEFROSTER) 17. Airflow mode sub link (HEAT) | <ol style="list-style-type: none"> 18. Airflow mode sub link (VENT) 19. Polyurethane protector (DEFROSTER) 20. Polyurethane protector (VENT) 21. Polyurethane foam 22. Polyurethane foam 23. Seal plate 24. Heater core 25. Airflow mode crank 26. Side VENT crank 27. Air mix door 28. Side VENT door 29. HEAT door 30. DEFROSTER door 31. Center VENT door 32. Heater case (1) 33. Heater case (2) |
|--|--|
- Inspection page U-16
- Assembly note page U-16

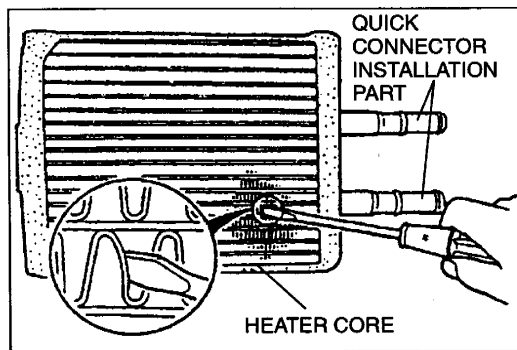
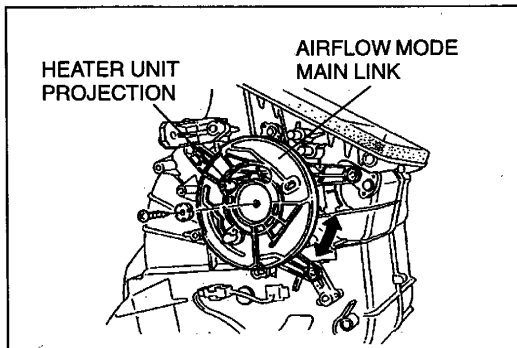
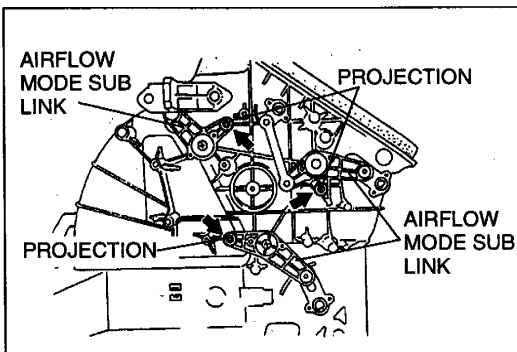

Assembly note

Airflow mode main link

1. Turn the projections of each airflow mode sub link outward.
2. Set the airflow mode main link to the heater unit as shown in the figure.
3. Press the airflow mode main link and rotate it in the direction of the arrow. Set the projections of each airflow mode sub link into the grooves of the airflow mode main link.
4. Rotate the airflow mode main link and verify that each mode is accessed properly.
5. Secure the airflow mode main link.

Inspection

Heater core

1. Disassemble the heater unit. (Refer to page U-15.)
2. Check for cracks, damage, and coolant leakage. Repair or replace the heater core if necessary.
3. Check for bent fins. If they are bent, use a flat-head screwdriver to straighten them.
4. Verify that the heater core inlet and outlet are not distorted or damaged. If the quick connector installation part is damaged, replace the heater core. (Refer to page U-15.)

COOLING UNIT

Removal / Installation

1. Discharge the refrigerant from the system.
2. Remove the side panel, glove compartment, and glove compartment cover. (Refer to section S1.)
3. If the air bag system is installed, remove the No.1 duct. (Refer to section S1.)
4. If the air bag system is installed, disconnect the air intake wire from the air intake link of the blower unit. (wire type)
5. Remove in the order shown in the figure. Do not allow compressor oil to spill. Immediately plug all open fittings to keep moisture and dirt out of the system.
6. Install in the reverse order of removal, referring to **Installation note**.
7. Adjust the air intake wire, charge the system and test its performance. (Refer to pages U-6 and 10.)

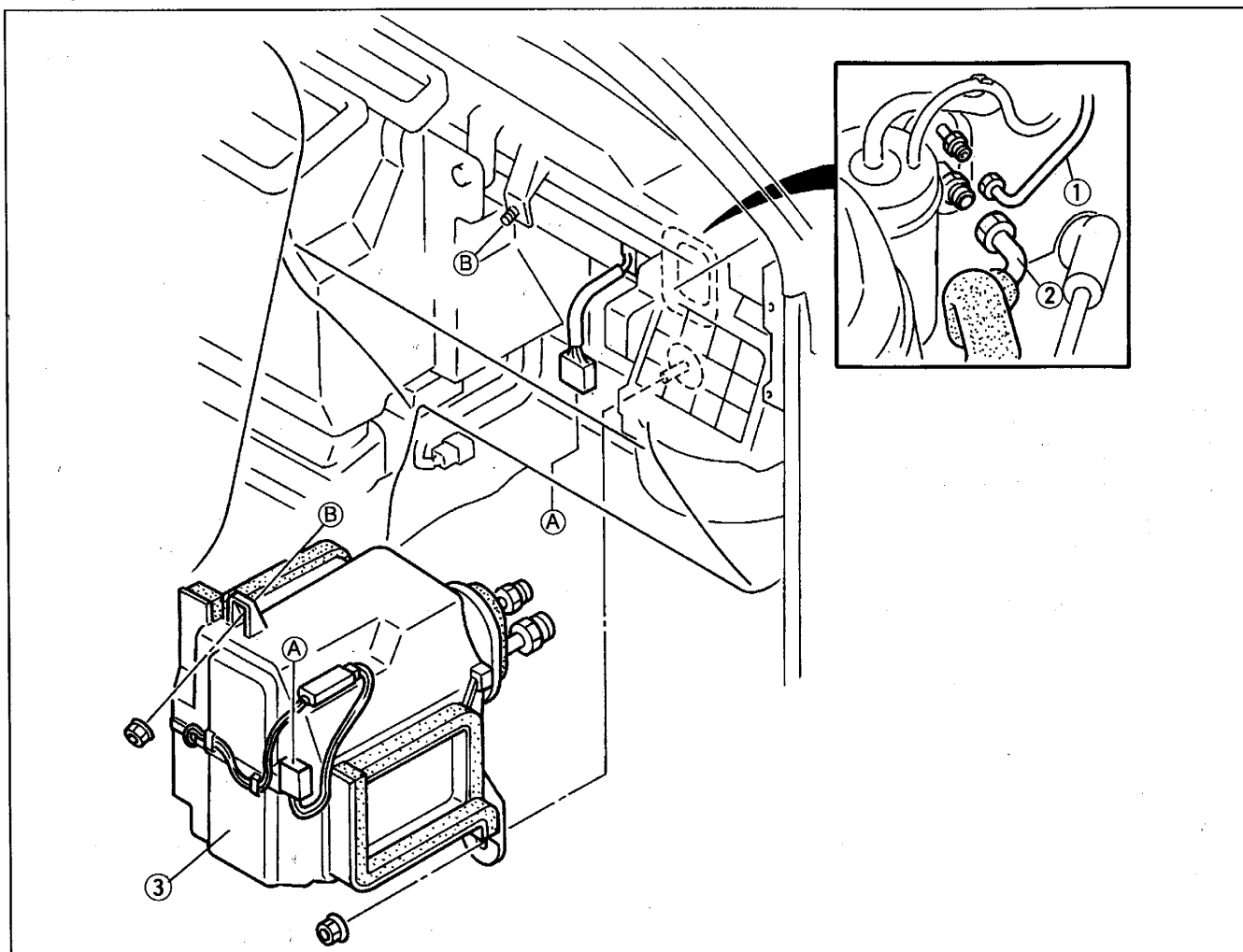

- | | |
|--|--|
| <ol style="list-style-type: none"> 1. Cooler pipe No.4
Removal / Installation page U-23 2. Cooler pipe No.5
Removal / Installation page U-23 | <ol style="list-style-type: none"> 3. Cooling unit
Installation note below
Disassembly / Assembly page U-18
Inspection page U-19 |
|--|--|

Installation note

When installing a new cooling unit (evaporator), add **50 ml { 50 cc , 1.7 fl oz }** of compressor oil through the high-pressure side of the A/C compressor.

Disassembly / Assembly

1. Disassemble in the order shown in the figure.
2. Assemble in the reverse order of disassembly, referring to **Assembly note**.

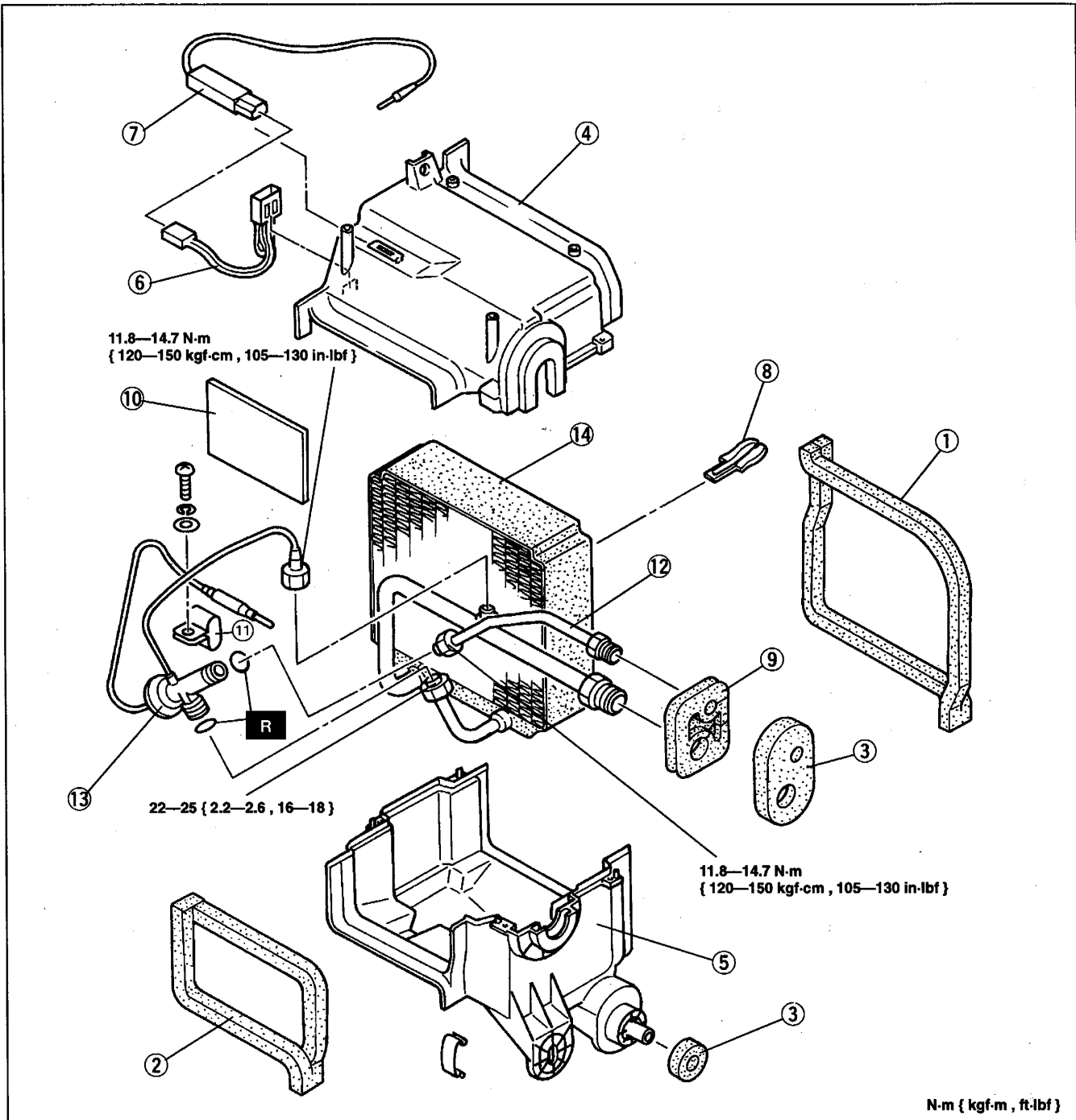

1. Polyurethane protector (heater side)
2. Polyurethane protector (blower side)
3. Polyurethane foam
4. Cooler case (top)
5. Cooler case (bottom)
6. A/C amplifier
7. Thermoswitch
Assembly note page U-19
8. Sensor clamp

9. Rubber protector
10. Sponge rubber
11. Bracket
12. Pipe
13. Expansion valve
Assembly note page U-19
14. Evaporator
Inspection page U-19

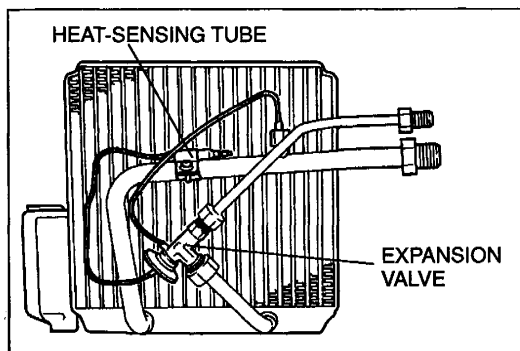

Assembly note
Expansion valve

1. Replace the O-rings at the expansion valve joints.
2. Apply compressor oil to the O-rings and connect the joints.
3. Tighten the joint to the specified torque by using two open-end wrenches. (Refer to page U-24.)
4. Assemble the heat-sensing tube as shown in the figure.

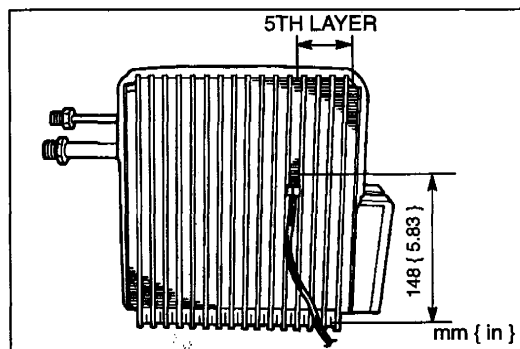

Thermoswitch

Assemble the sensor part of the thermoswitch as shown in the figure.

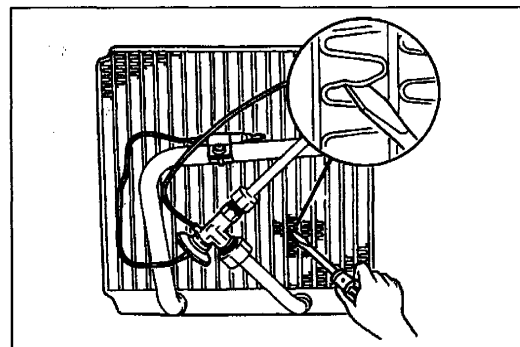

Inspection
Evaporator

1. Disassemble the cooling unit. (Refer to page U-18.)
2. Check for cracks, damage and oil leakage. Repair or replace the evaporator if necessary.
3. Check for bent fins. If they are bent, use a flat-head screwdriver to straighten them.

A/C COMPRESSOR

Removal / Installation

1. Discharge the refrigerant from the system.
2. Remove the undercover, splash shield (RH), and A/C drive belt. (Refer to section B1 or B2.)
3. Remove in the order shown in the figure. Do not allow compressor oil to spill. Immediately plug all open fittings to keep moisture out of the system.
4. Install in the reverse order of removal, referring to **Installation note**.
5. Charge the system and test its performance. (Refer to pages U-6 and 10.)

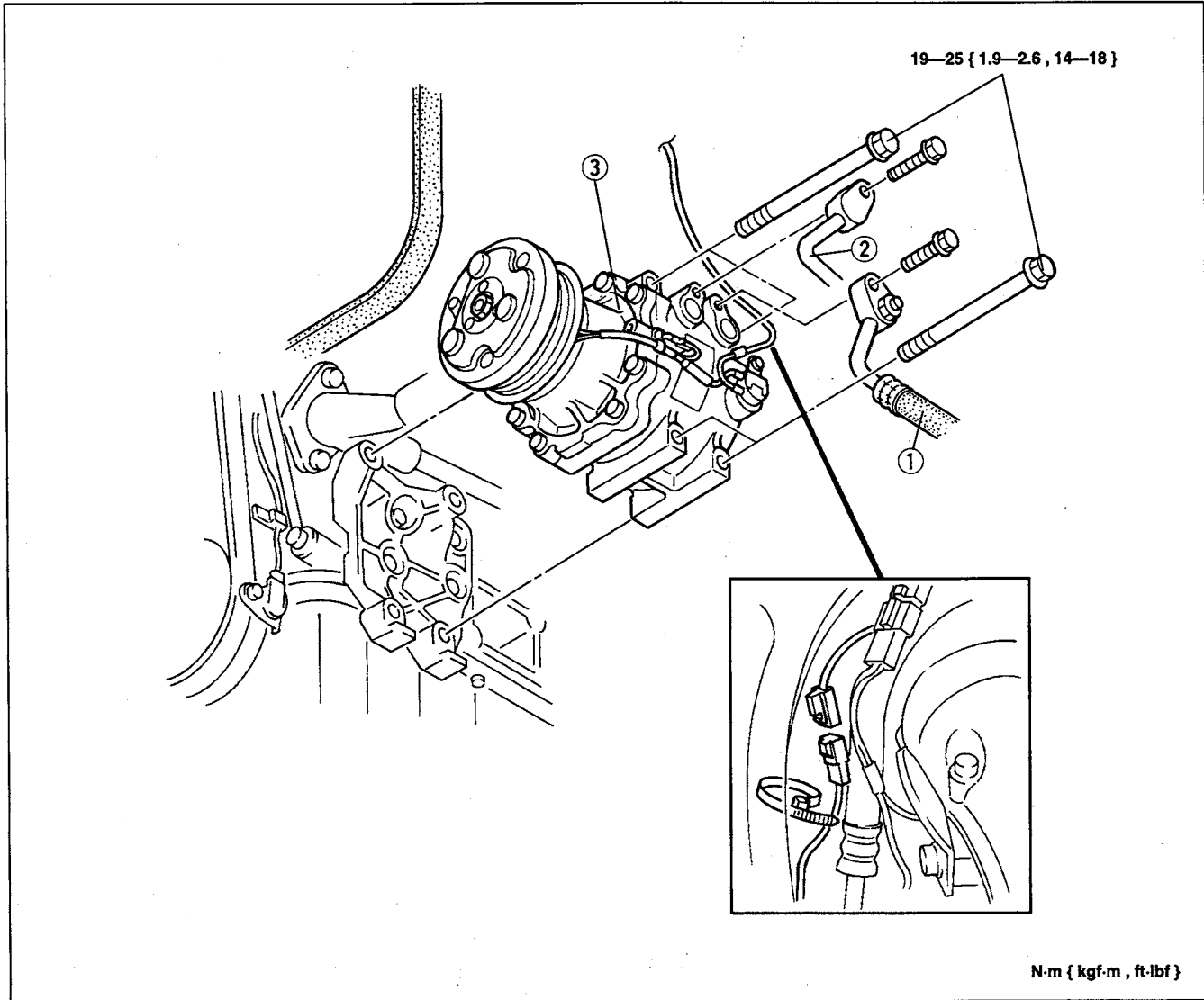

- | | |
|---|--|
| <p>1. Flexible hose (HI)
Removal / Installation page U-23</p> <p>2. Flexible hose (LO)
Removal / Installation page U-23</p> | <p>3. A/C compressor
Installation note below</p> |
|---|--|

Installation note

Follow the procedure below when replacing the A/C compressor with a new one:

1. Measure the amount of compressor oil remaining in the old A/C compressor.
2. Remove the following amount of compressor oil from the new A/C compressor.

Compressor oil to be removed

= 120 ml { 120 cc , 4.06 fl oz } - [compressor oil from old A/C compressor + 5-10 ml { 5-10 cc , 0.2-0.3 fl oz }]

CONDENSER

Removal / Installation

1. Discharge the refrigerant from the system.
2. Remove the upper seal board. (Refer to section E.)
3. Remove the radiator grille. (Refer to section S1.)
4. Remove the undercover. (Refer to section B1 or B2.)
5. Remove in the order shown in the figure. Do not allow compressor oil to spill. Immediately plug all open fittings to keep moisture out of the system.
6. Install in the reverse order of removal, referring to **Installation note**.
7. Charge the system and test its performance. (Refer to pages U-6 and 10.)

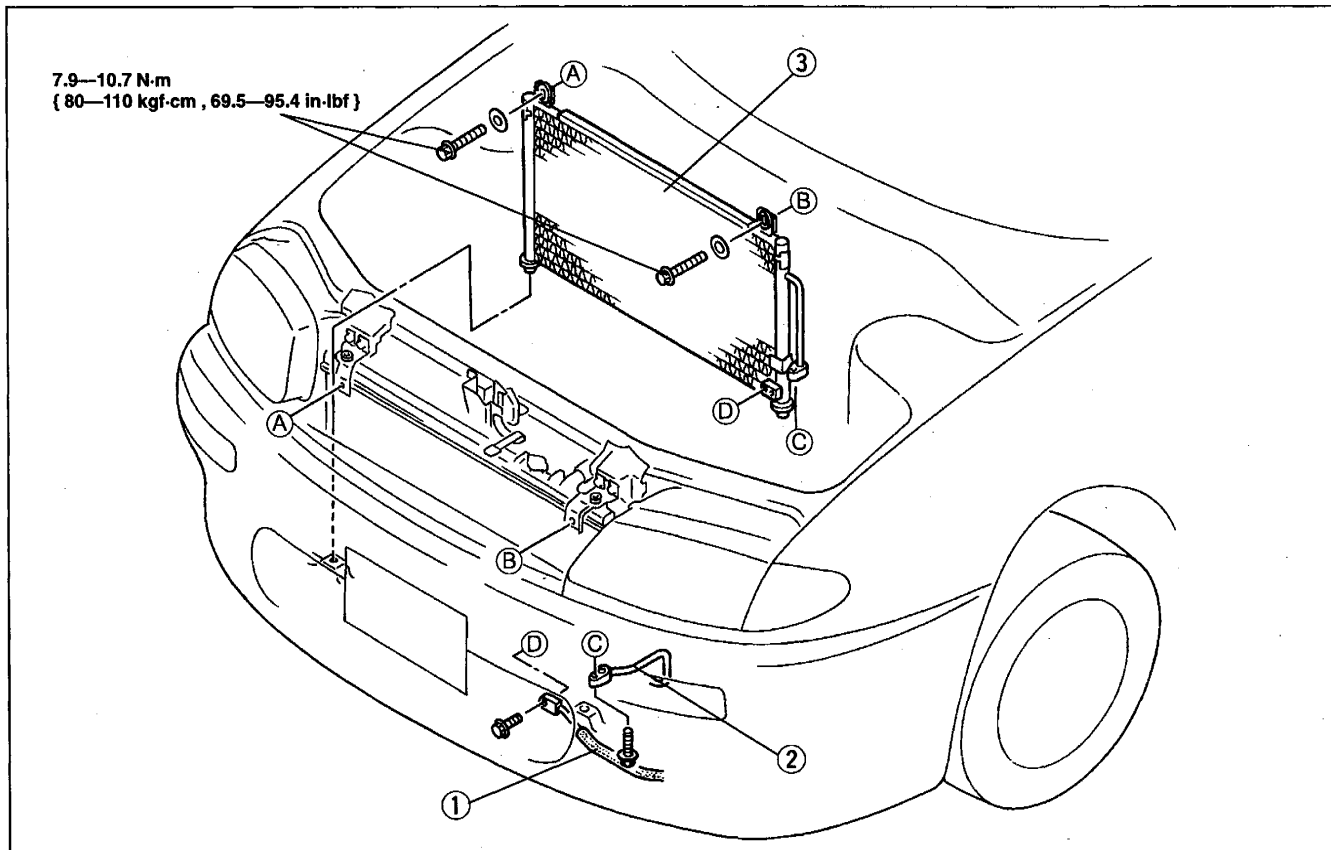

- | | |
|---|--|
| <p>1. Cooler pipe No.1
Removal / Installation page U-23</p> <p>2. Flexible hose (HI)
Removal / Installation page U-23</p> | <p>3. Condenser
Installation note below
Inspection below</p> |
|---|--|

Installation note

When installing a new condenser, add **15 ml { 15 cc , 0.5 fl oz }** of compressor oil through the high-pressure side of the A/C compressor.

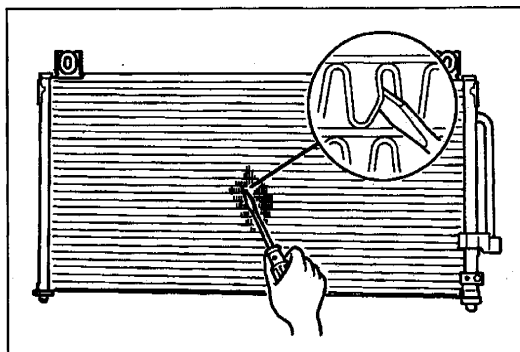

Inspection

1. Check for cracks, damage, and oil leakage. Repair or replace the condenser if necessary.
2. Check for bent fins. If they are bent, use a flat-head screwdriver to straighten them.

RECEIVER/DRIER

Removal / Installation

1. Discharge the refrigerant from the system.
2. Remove the undercover and the splash shield (LH). (Refer to section B1 or B2.)
3. Remove the mud guard (LH). (Refer to section S1.)
4. Remove in the order shown in the figure. Do not allow compressor oil to spill. Immediately plug all open fittings to keep moisture out of the system.
5. Install in the reverse order of removal, referring to **Installation note**.
6. Charge the system and test its performance. (Refer to pages U-6 and 10.)

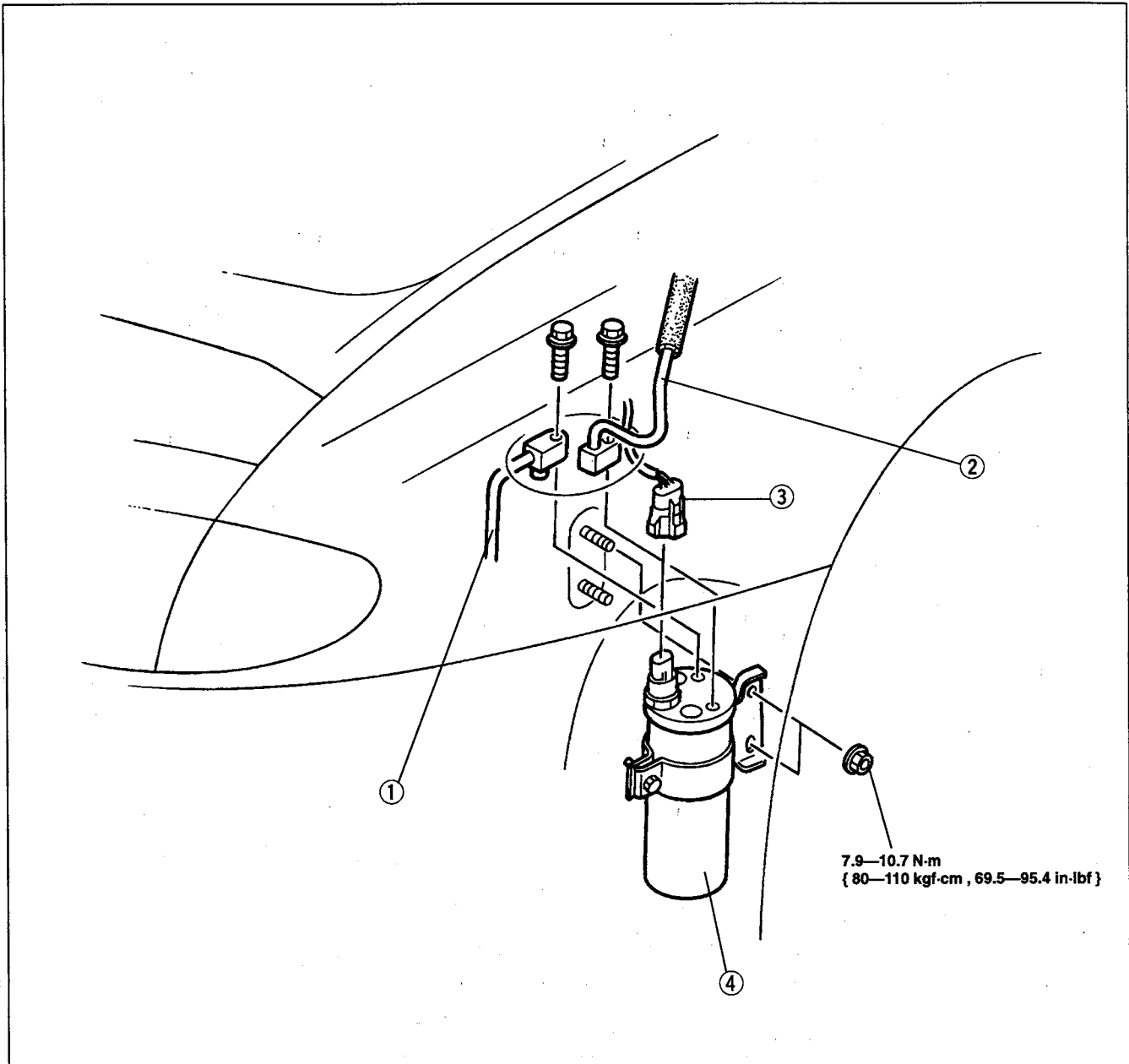

- | | |
|---|--|
| 1. Cooler pipe No.2
Removal / Installation page U-23 | 3. Refrigerant pressure switch connector |
| 2. Cooler pipe No.3
Removal / Installation page U-23 | 4. Receiver/drier
Installation note below |

Installation note

When installing a new receiver/drier, add **10 ml { 10 cc , 0.3 fl oz }** of compressor oil through the high-pressure side of the A/C compressor.

REFRIGERANT LINES

Removal / Installation

1. Discharge the refrigerant from the system.
2. Remove the following parts, depending on pipe and hose to be removed.

Cooler pipe/hose to be removed	Parts to be removed	Section
Flexible hose (HI)	Undercover, Splash shields, Engine mount member	B1, B2
Flexible hose (LO)	Undercover, Splash shield (RH)	B1, B2
Cooler pipe No.1, No.2	Undercover, Splash shield (LH)	B1, B2
	Mud guard (LH)	S1
Cooler pipe No.4, No.5	Charcoal canister	F1, F2
	Cruise actuator (if equipped)	T1

3. Remove as shown in the figure. Do not allow compressor oil to spill. Immediately plug all open fittings to keep moisture out of the system.
4. Install in the reverse order of removal, referring to **Installation note**.
5. Charge the system and test its performance. (Refer to pages U-6 and 10.)

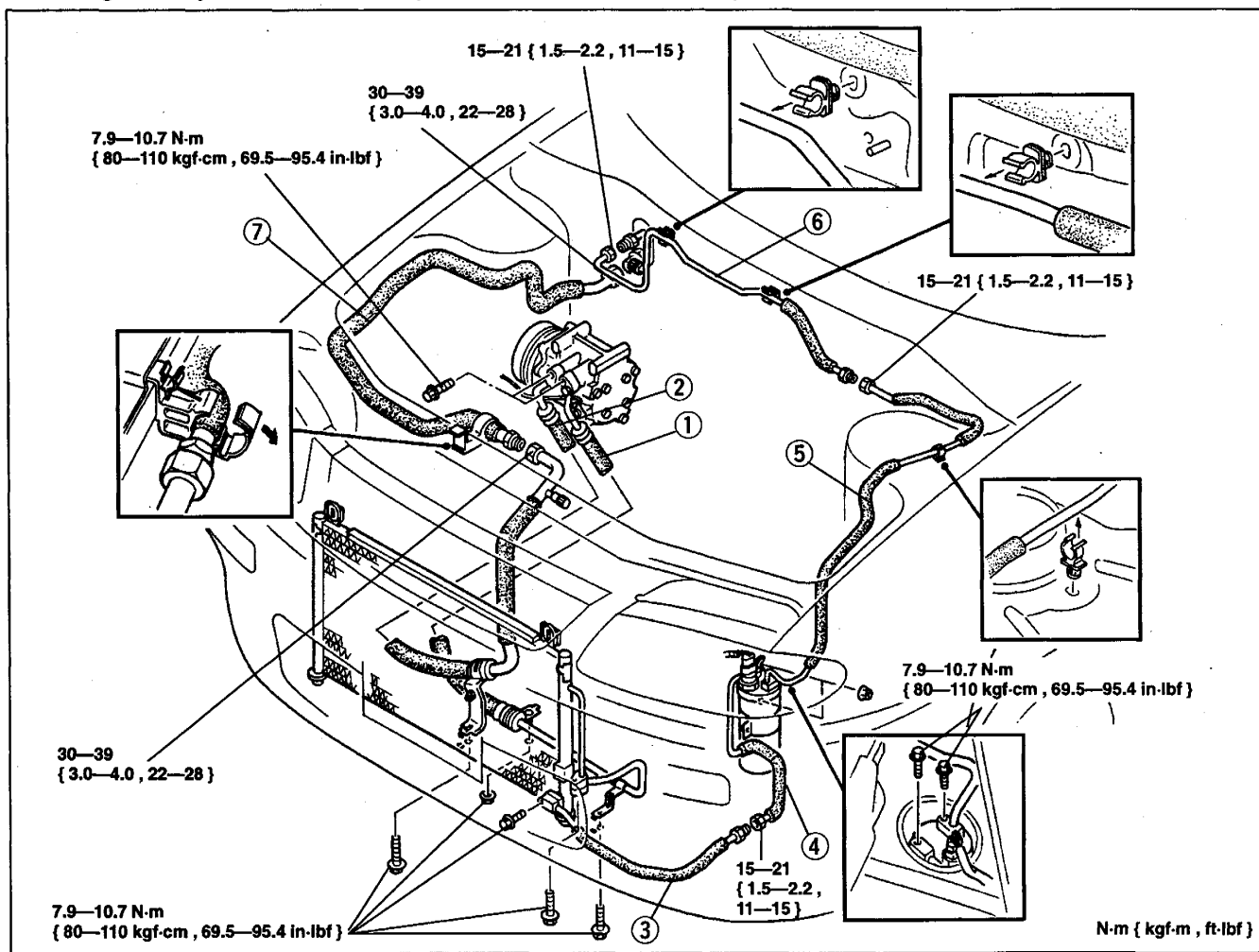

- | | |
|-----------------------|-----------------|
| 1. Flexible hose (HI) | |
| Installation note | page U-24 |
| 2. Flexible hose (LO) | |
| Installation note | page U-24 |
| 3. Cooler pipe No.1 | |
| Installation note | page U-24 |
| 4. Cooler pipe No.2 | |
| Installation note | page U-24 |

- | | |
|---------------------|-----------------|
| 5. Cooler pipe No.3 | |
| Installation note | page U-24 |
| 6. Cooler pipe No.4 | |
| Installation note | page U-24 |
| 7. Cooler pipe No.5 | |
| Installation note | page U-24 |

Installation note

1. Replace the O-rings at the pipe and/or hose joints, when installing pipes.
2. Apply compressor oil to the O-rings and connect the joints.
3. When installing a new cooler pipe or flexible hose, add **10 ml { 10 cc , 0.3 fl oz }** of compressor oil through the high-pressure side of the A/C compressor.

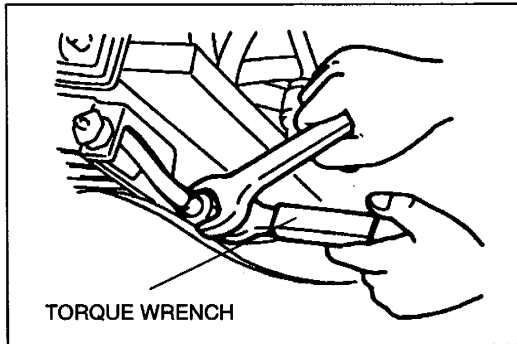

4. Tighten the joints.
 - (1) Verify that the O-rings are installed.
 - (2) Tighten the nut or bolt of the joint by hand.
 - (3) Fix the bracket and clip installed on the hose or pipe to the vehicle.
 - (4) Tighten the joint to the specified torque. If it is nut joint, tighten in the procedure as the figure.

REAR HEAT DUCT**Removal / Installation**

1. Remove the front seat. (Refer to section S1.)
2. Remove the center console and side wall. (Refer to section S1.)
3. Remove the PCM. (Refer to section F1 or F2.)
4. Remove the front scuff plate and front side trim, and turn over the floor covering. (Refer to section S1.)
5. Remove in the order shown in the figure.
6. Install in the reverse order of removal.

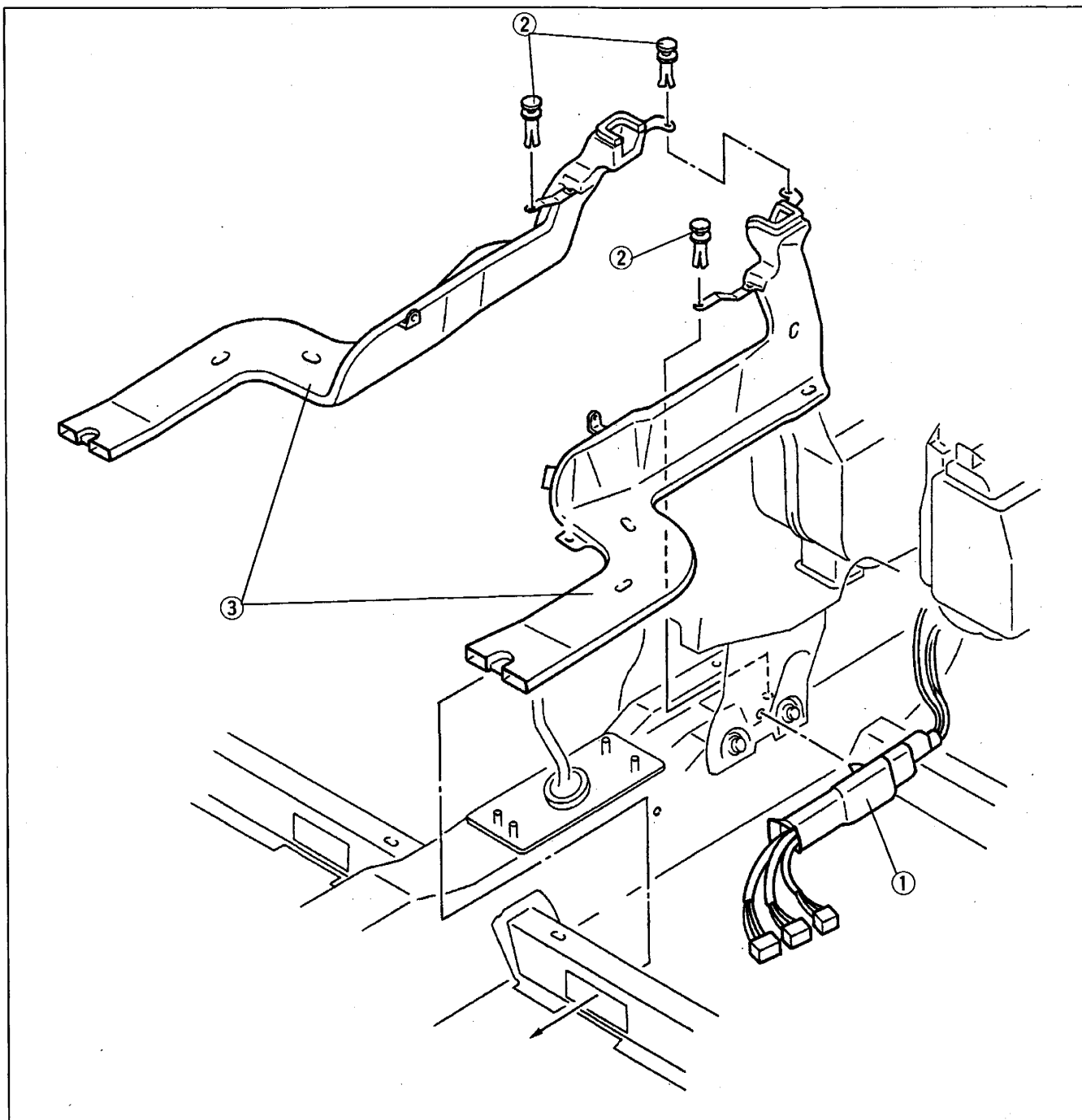

1. PCM harness
2. Fastener

3. Rear heat duct

CONTROL SYSTEM

PREPARATION SST

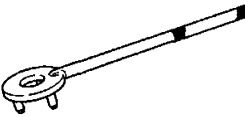
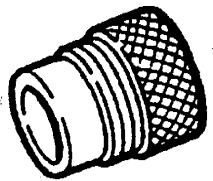
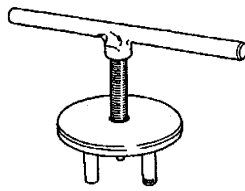
<p>49 B061 010</p> <p>A/C clutch holder</p> 	<p>For prevention of A/C compressor pulley rotation</p>	<p>49 G032 311</p> <p>Oil seal and spacer installer guide</p> 	<p>For installation of A/C compressor pulley</p>
<p>49 B061 013</p> <p>Pressure plate remover</p> 	<p>For removal of pressure plate</p>	<p>—</p>	<p>—</p>

STRUCTURAL VIEW

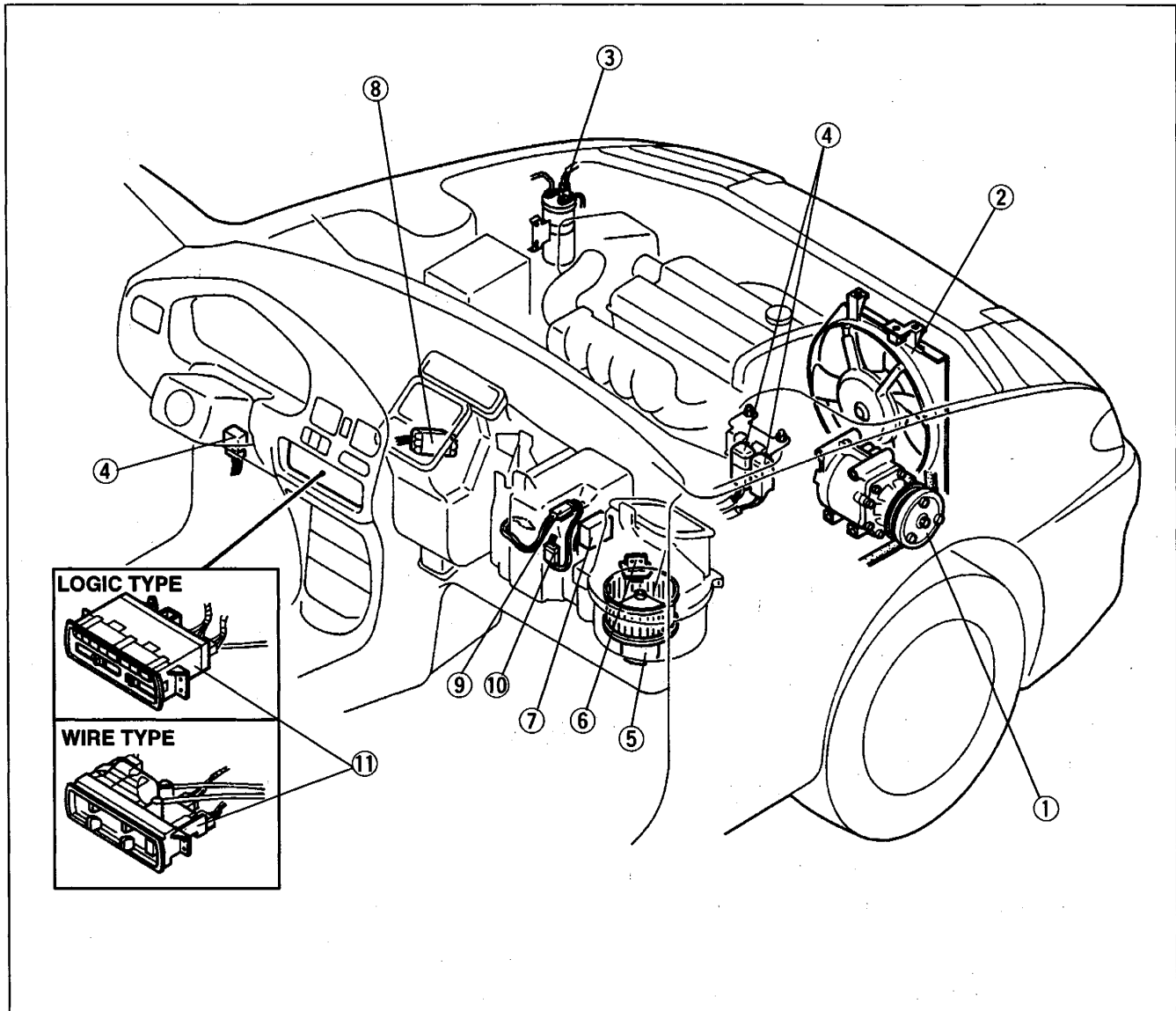

1. Magnetic clutch Disassembly / Assembly below Inspection page U-29	7. Air intake actuator Removal / Installation page U-33 Inspection page U-33
2. Condenser fan Removal / Installation page U-30 Inspection page U-30	8. Airflow mode actuator Removal / Installation page U-33 Inspection page U-33
3. Refrigerant pressure switch Removal / Installation page U-31 Inspection page U-31	9. Thermoswitch Removal / Installation page U-34 Inspection page U-34
4. Relay Removal / Installation page U-31 Inspection page U-32	10. A/C amplifier Removal / Installation page U-34 Inspection page U-34
5. Blower motor Removal / Installation page U-32 Inspection page U-32	11. Heater control unit Removal / Installation page U-36 Disassembly / Assembly page U-39 Inspection page U-41
6. Resistor Removal / Installation page U-32 Inspection page U-32	

MAGNETIC CLUTCH

Disassembly / Assembly

1. Remove the A/C compressor. (Refer to page U-20.)
2. Disassemble in the order shown in the figure, referring to **Disassembly note**.
3. Assemble in the reverse order of disassembly, referring to **Assembly note**.

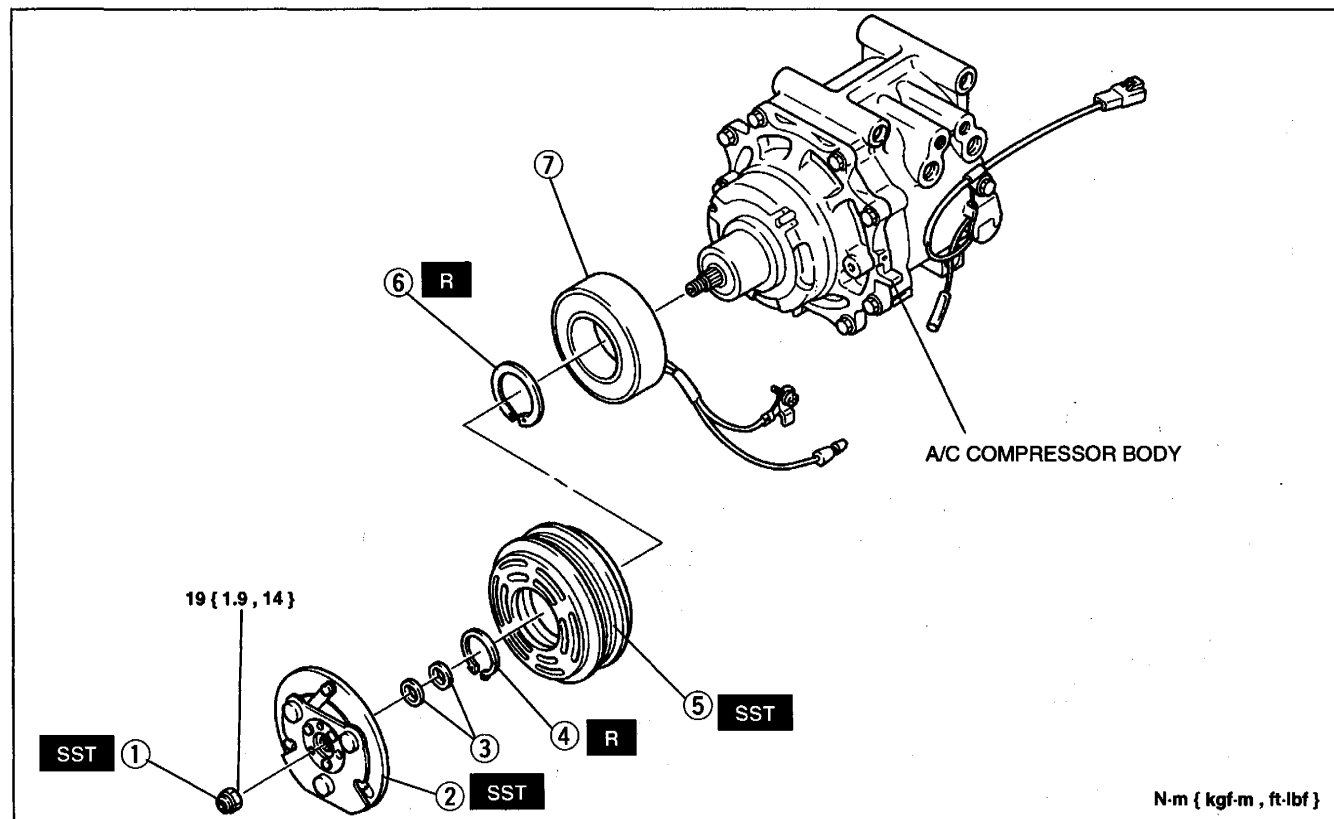

1. Center nut Disassembly note page U-28	5. A/C compressor pulley Disassembly note page U-28 Assembly note page U-29
2. Pressure plate Disassembly note page U-28 Assembly note page U-29	6. Snap ring
3. Shim	7. Stator Assembly note page U-28 Inspection page U-29
4. Snap ring	

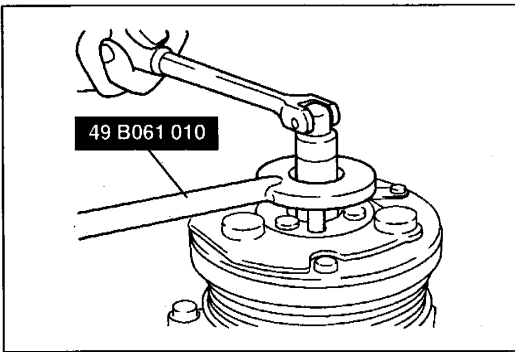

Disassembly note

Center nut

Hold the pressure plate in place by using the **SST** and remove the center nut.

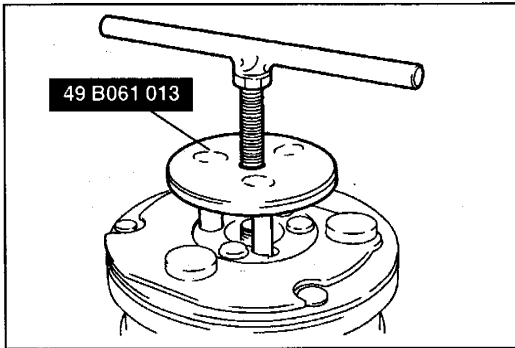

Pressure plate

If the pressure plate cannot be removed by hand, use the **SST** as shown in the figure.

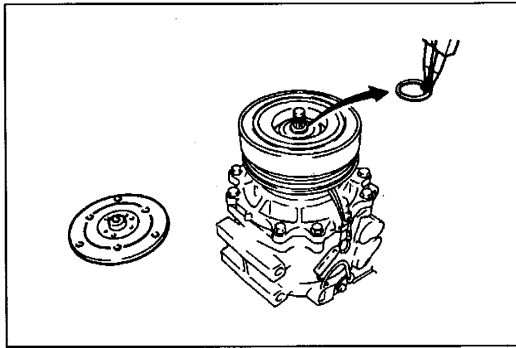

A/C compressor pulley

1. Remove the snap ring by using snap-ring pliers.

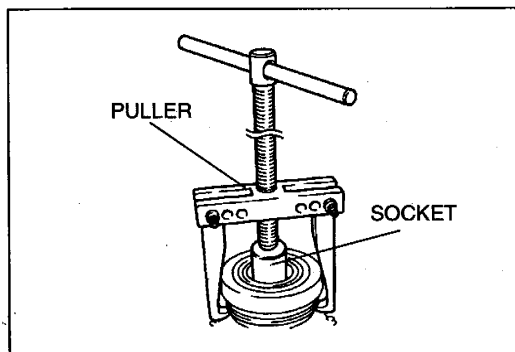

Caution

- The edge of the puller can damage the drive belt groove. Avoid contact of the puller to the pulley groove.

2. Set a 25 mm { 1.0 in } socket and a puller on the A/C compressor as shown in the figure.
3. Turn the shaft of the puller to remove the A/C compressor pulley.

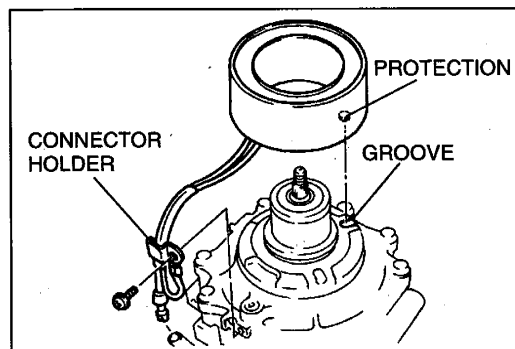

Assembly note

Stator

1. Set the projection of the stator to the A/C compressor body groove as shown in the figure.
2. Connect the connector and install the connector holder.

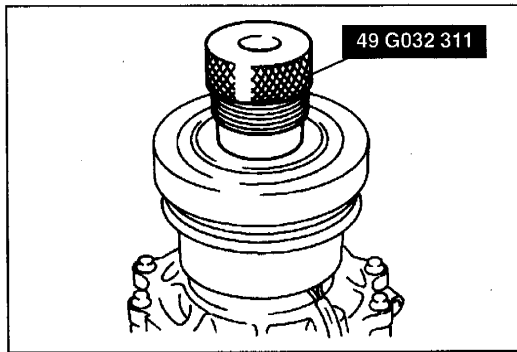
**A/C compressor pulley**

1. Remove all foreign material from the boss of the A/C compressor and inside the bearing of the A/C compressor pulley.
2. Set the **SST** as shown in the figure.
3. Press the **SST** to assemble the A/C compressor pulley.

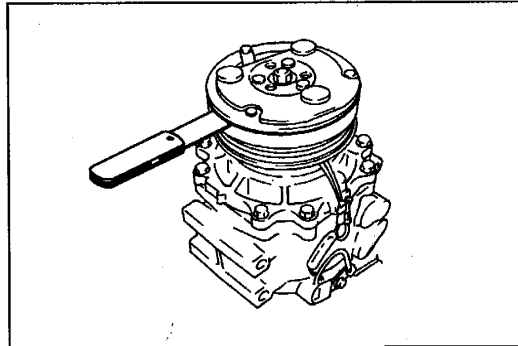
**Pressure plate**

1. Adjust the clearance between the pressure plate and the A/C compressor pulley.
 - (1) Set the A/C compressor on a level block.
 - (2) Rotate the A/C compressor pulley and measure the clearance between the A/C compressor pulley and the pressure plate by using a thickness gauge.

Clearance: 0.35—0.65 mm { 0.014—0.025 in }

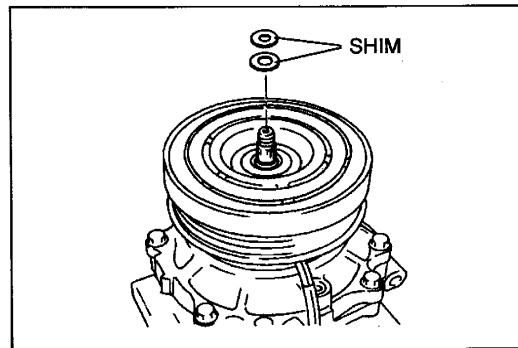

2. If not as specified, install shims to adjust the clearance.

Adjustment shim size:

**0.1 mm { 0.004 in }, 0.2 mm { 0.008 in },
0.4 mm { 0.016 in }, 0.5 mm { 0.02 in }**

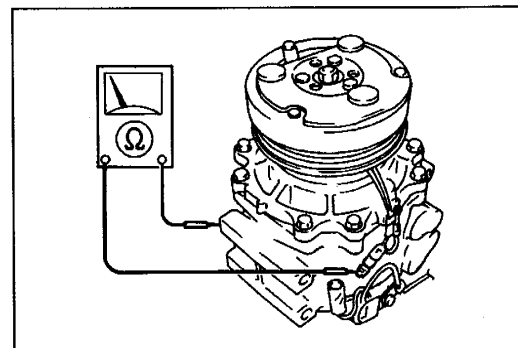
**Inspection****Stator**

1. Disconnect the stator connector.
2. Measure the resistance between the stator connector and the A/C compressor body.

Resistance: 3.05—3.35 Ω [at 20 °C { 68 °F }]

3. If not as specified, replace the stator.

CONDENSER FAN

Removal / Installation

1. Remove the upper seal board, radiator grille, and radiator brackets. (Refer to sections E, S1.)
2. Remove in the order shown in the figure.
3. Install in the reverse order of removal.

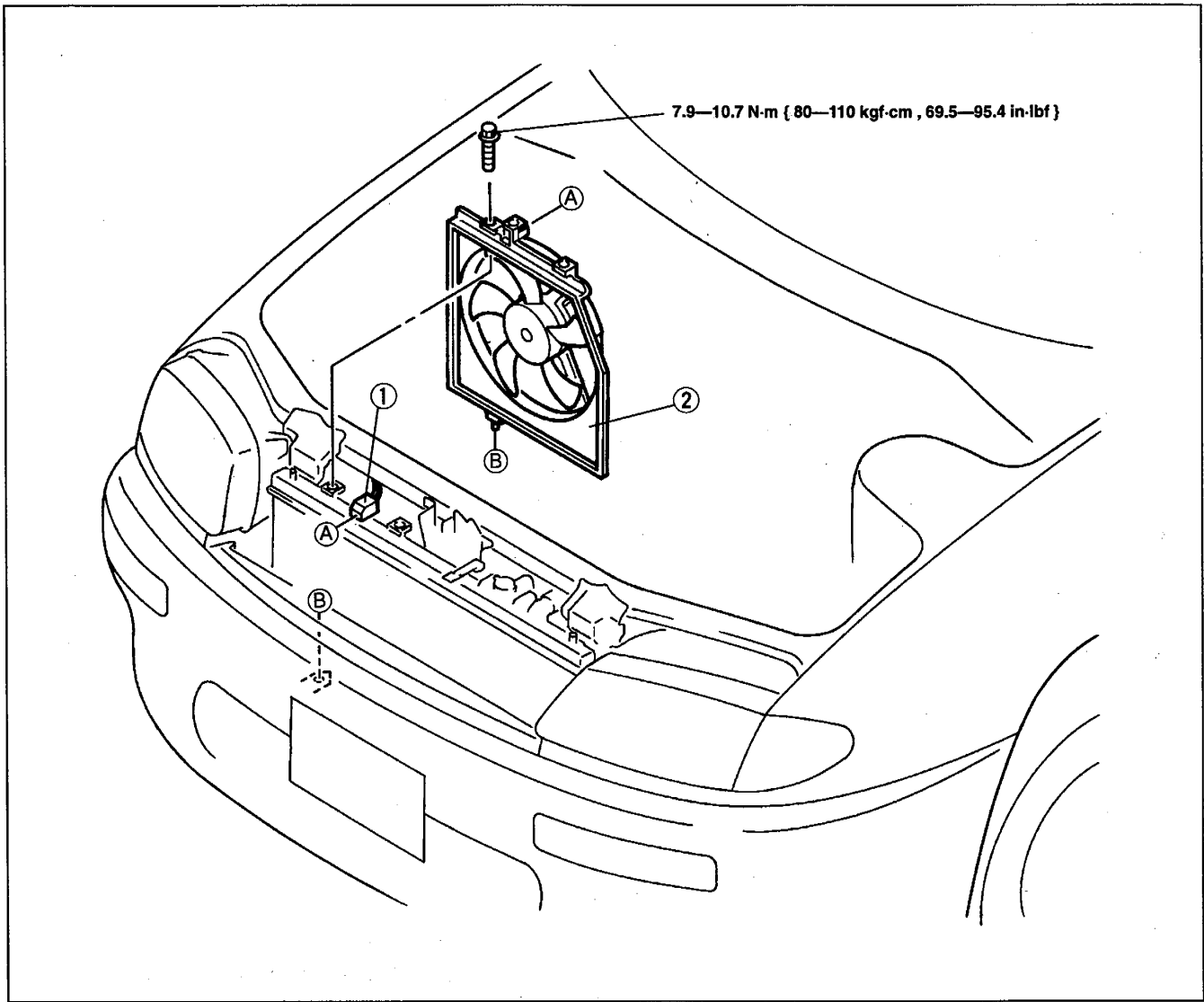

1. Condenser fan connector

2. Condenser fan
Inspection below

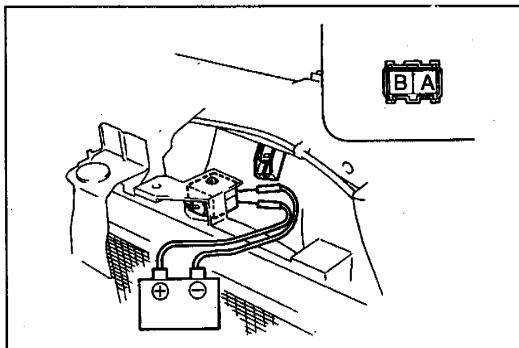

Inspection

1. Disconnect the condenser fan connector.
2. Connect battery positive voltage to terminal A and ground to terminal B of the condenser fan and check its operation.
3. If condenser fan does not operate, replace the condenser fan.

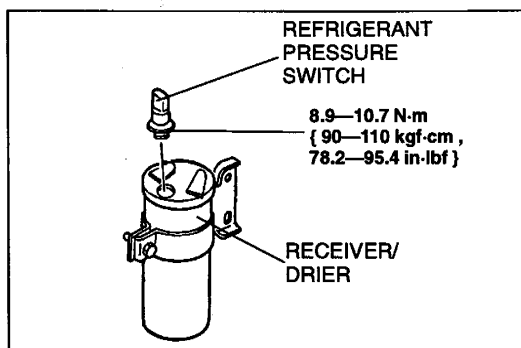

REFRIGERANT PRESSURE SWITCH

Removal / Installation

1. Remove the receiver/drier. (Refer to page U-22.)
2. Remove the refrigerant pressure switch from the receiver/drier. Immediately plug the open fitting to keep moisture out of the system.
3. Install in the reverse order of removal. Before installing the refrigerant pressure switch, apply compressor oil to the O-ring and connect the joint.
4. Charge the system and test its performance. (Refer to pages U-6 and 10.)

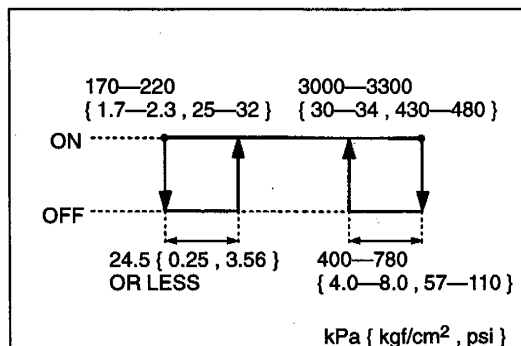

Inspection

1. Install the manifold gauge set. (Refer to page U-5.)
2. Make sure that the high-pressure side is in the ON range shown in the figure.

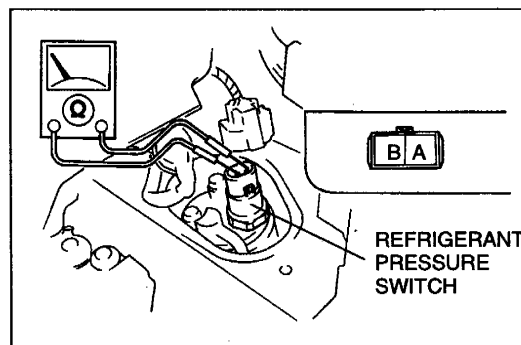

3. Disconnect the refrigerant pressure switch connector.
4. Verify that there is continuity between terminals A and B of the refrigerant pressure switch.
5. If there is no continuity, replace the refrigerant pressure switch.

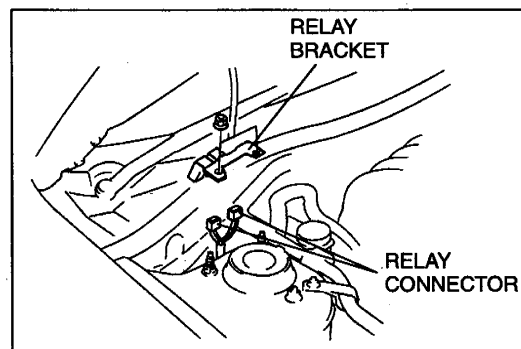

RELAY

Removal / Installation

A/C relay, condenser fan relay

1. If the cruise control system is installed, remove the cruise actuator with the actuator cable still connected and position it away from the suspension tower.
2. Remove the relay bracket.
3. Disconnect the relay connectors.
4. Install in the reverse order of removal.

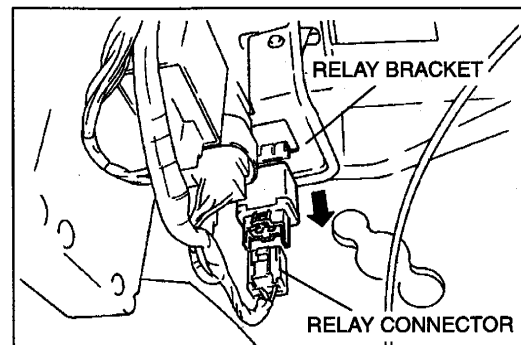

Blower relay

1. Disconnect the relay connector.
2. Remove the blower relay from the relay bracket.
3. Install in the reverse order of removal.

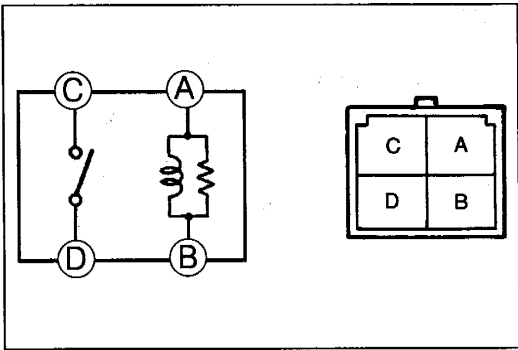

Inspection

A/C relay, condenser fan relay, blower relay

1. Remove the relay. (Refer to page U-31.)
2. Connect battery positive voltage and check for continuity between terminals of the relay.

○—○: Continuity B+: Battery positive voltage

Connection		A	B	C	D
B+	GND				
—	—	○—○	○—○		
A	B			○—○	○—○

3. If not as specified, replace the relay.

BLOWER MOTOR

Removal / Installation

1. Remove the blower motor cover.
2. Disconnect the blower motor connector.
3. Remove the blower motor connector from the connector bracket.
4. Remove the air hose.
5. Remove the screws and the blower motor.
6. Install in the reverse order of removal.

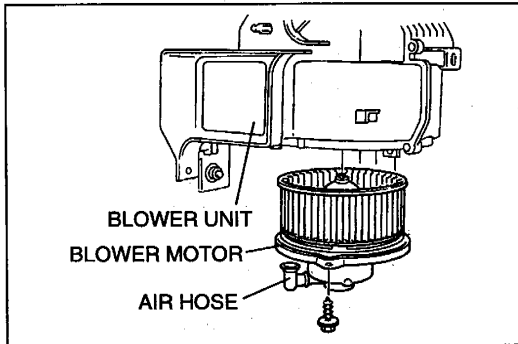

Inspection

1. Disconnect the blower motor connector.
2. Connect battery positive voltage to terminal B and ground to terminal A of the blower motor. Verify that the blower motor operates.
3. If blower motor does not operate, replace the blower motor.

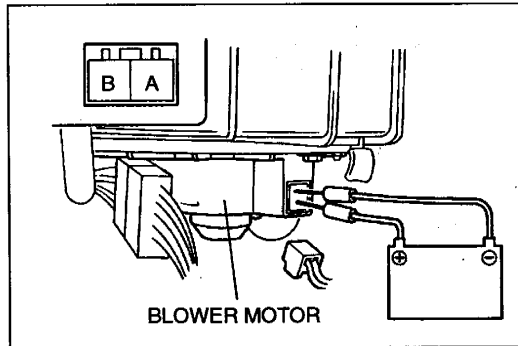

RESISTOR

Removal / Installation

1. Disconnect the resistor connector.
2. Remove the screws and the resistor.
3. Install in the reverse order of removal.

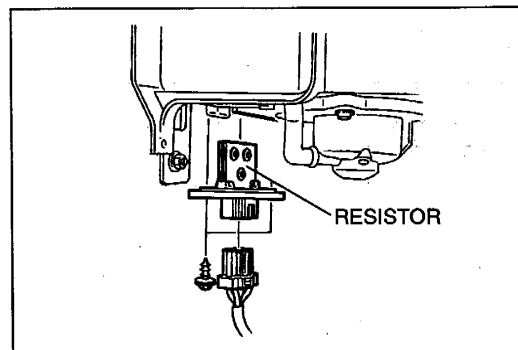

Inspection

1. Disconnect the resistor connector.
2. Verify that the resistance between terminals of the resistor is as shown below.

Terminal	Resistance (Ω)
C—D	0.3—0.6
C—E	1.0—1.6
C—A	2.8—6.0

3. If not as specified, replace the resistor.

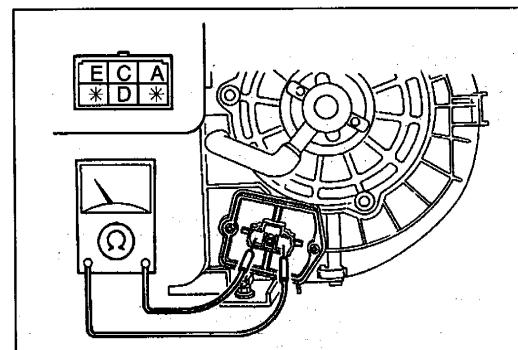

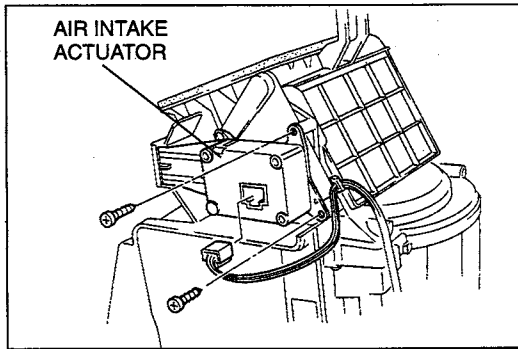

AIR INTAKE ACTUATOR

Removal / Installation

1. Remove the glove compartment and the glove compartment cover. (Refer to section S1.)
2. If the air bag system is installed, remove the No.1 duct. (Refer to section S1.)
3. Pull out the air intake actuator by removing the screws.
4. Disconnect the air intake actuator connector and remove the air intake actuator.
5. Install in the reverse order of removal.

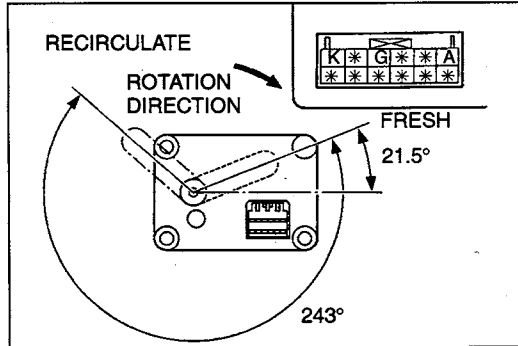

Inspection

1. Remove the air intake actuator.
2. Connect battery positive voltage to terminal A and ground to terminal G or K of the air intake actuator.
3. Verify that the air intake actuator operates as shown below.

B+: Battery positive voltage

Connection		Movement
B+	GND	
A	G	FRESH to RECIRCULATE
A	K	RECIRCULATE to FRESH

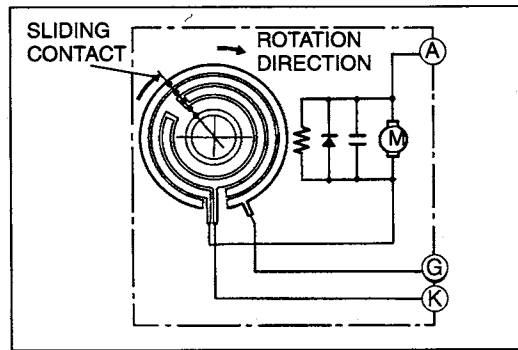

4. If not as specified, replace the air intake actuator.

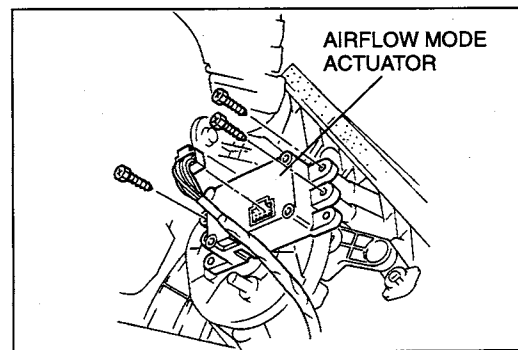

AIRFLOW MODE ACTUATOR

Removal / Installation

1. Disconnect the airflow mode actuator connector.
2. Remove the screws and the airflow mode actuator.
3. Install in the reverse order of removal.

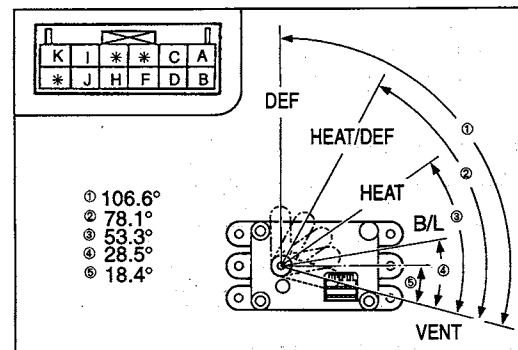

Inspection

1. Remove the airflow mode actuator.
2. Connect battery positive voltage to terminal J or I and ground to terminal I or J of the airflow mode actuator.
3. Verify that the airflow mode actuator operates as shown below.

B+: Battery positive voltage

Connection		Movement
B+	GND	
J	I	VENT to DEFROSTER
I	J	DEFROSTER to VENT

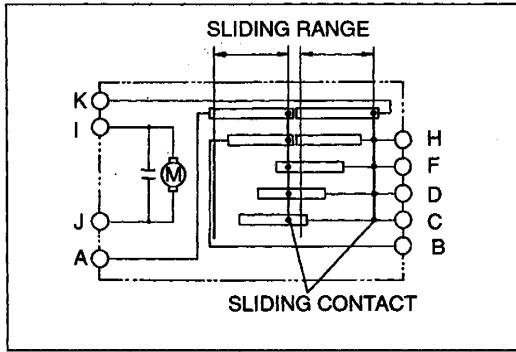

4. Check for continuity between the terminals of the air-flow mode actuator as shown below.

○—○: Continuity

Terminal / Mode	A	B	C	D	F	H	K
VENT			○—○	○—○	○—○	○—○	○—○
BI-LEVEL	○—○	○—○		○—○	○—○	○—○	○—○
HEAT	○—○	○—○	○—○		○—○	○—○	○—○
HEAT/DEF	○—○	○—○	○—○	○—○		○—○	○—○
DEFROSTER	○—○	○—○	○—○	○—○	○—○		

5. If not as specified, replace the airflow mode actuator.

THERMOSWITCH

Removal / Installation

1. Remove the cooling unit. (Refer to page U-17.)
2. Remove the thermostat from the cooling unit. (Refer to page U-18.)
3. Install in the reverse order of removal.

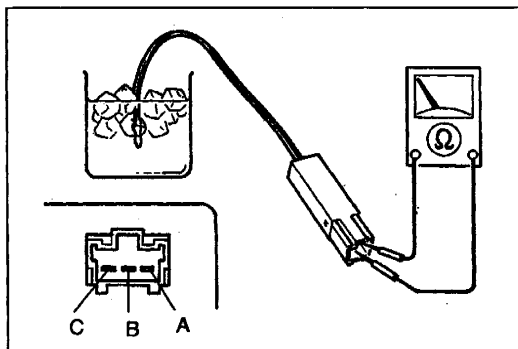

Inspection

1. Remove the thermostat.
2. Immerse the sensor part of the thermostat in a container of ice water.
3. Check for continuity between terminals A and B of the thermostat.

○—○: Continuity

Temperature / Terminal	A	B
3.6 °C { 38 °F } or more	○—○	○—○
0.8 °C { 33 °F } or less		

4. If not as specified, replace the thermostat.

A/C AMPLIFIER

Removal / Installation

1. Remove the cooling unit. (Refer to page U-17.)
2. Remove the A/C amplifier from the cooling unit. (Refer to page U-18.)
3. Install in the reverse order of removal.

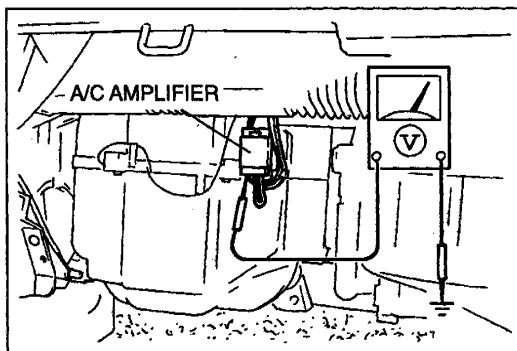

Inspection

1. Remove the glove compartment and the glove compartment cover. (Refer to section S1.)
2. Start the engine.
3. Measure the voltage at the terminals of the A/C amplifier connector and refer to the terminal voltage list. (Refer to page U-35.)
4. If not as specified, inspect the appropriate area.
5. If the inspection area is OK, replace the A/C amplifier.

Terminal voltage (Reference)

B+: Battery positive voltage

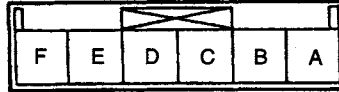

Terminal	Signal name	Connection	Test condition	Voltage (V)	Inspection area
A	IG2	A/C 10 A fuse	Ignition switch at ON	B+	<ul style="list-style-type: none"> Continuity [Fuse—A/C amplifier: A/C 10 A—A] A/C 10 A fuse
			Ignition switch at LOCK, ACC, START	0	
B	A/C signal	Refrigerant pressure switch	Magnetic clutch on	MAX. 1	<ul style="list-style-type: none"> Continuity [PCM—Refrigerant pressure switch: 1K—B, Refrigerant pressure switch—A/C amplifier: A—B] Terminal voltage of A/C amplifier (C) Refrigerant pressure switch (Refer to page U-31) PCM (Refer to section F1 or F2)
			Magnetic clutch off	B+	
C	A/C switch signal	<ul style="list-style-type: none"> A/C switch (wire type) Heater control unit (logic type) 	A/C switch off	B+	Terminal voltage of A/C amplifier (A)
			A/C switch on and fan switch at 1st position	0	(Wire type) <ul style="list-style-type: none"> Continuity [A/C amplifier—A/C switch: C—D, Fan switch (B)—GND] A/C switch (Refer to page U-42) Fan switch (Refer to page U-41)
					(Logic type) <ul style="list-style-type: none"> Continuity [A/C amplifier—Heater control unit: C—B, Heater control unit—Fan switch: D—D, Fan switch (B)—Ground] Heater control unit (Refer to page U-42) Fan switch (Refer to page U-41)
D	—	—	—	—	—
E	—	—	—	—	—
F	—	—	—	—	—

HEATER CONTROL UNIT

Removal / Installation

Wire type

1. Remove the meter hood, side panel, glove compartment, and glove compartment cover.
(Refer to section S1.)
2. Remove in the order shown in the figure.
3. Install in the reverse order of removal.

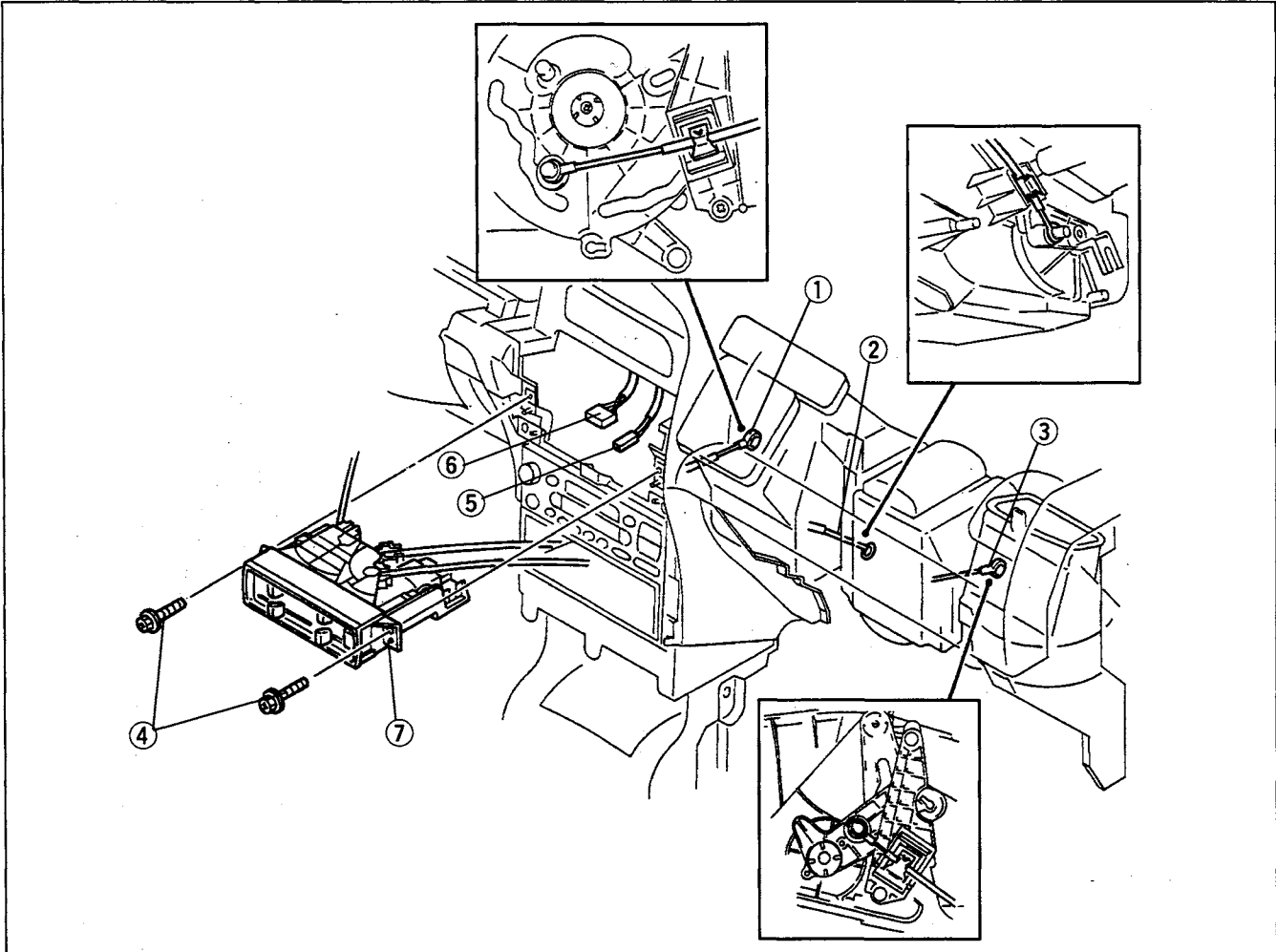

- | | |
|---|--|
| <ol style="list-style-type: none"> 1. Airflow mode wire
Wire adjustment page U-38 2. Air mix wire
Wire adjustment page U-38 3. Air intake wire
Wire adjustment page U-38 | <ol style="list-style-type: none"> 4. Screw 5. Fan switch connector 6. Heater control unit connector 7. Heater control unit
Disassembly / Assembly page U-39 |
|---|--|

Logic type

1. Remove the meter hood. (Refer to section S1.)
2. Remove in the order shown in the figure.
3. Install in the reverse order of removal.

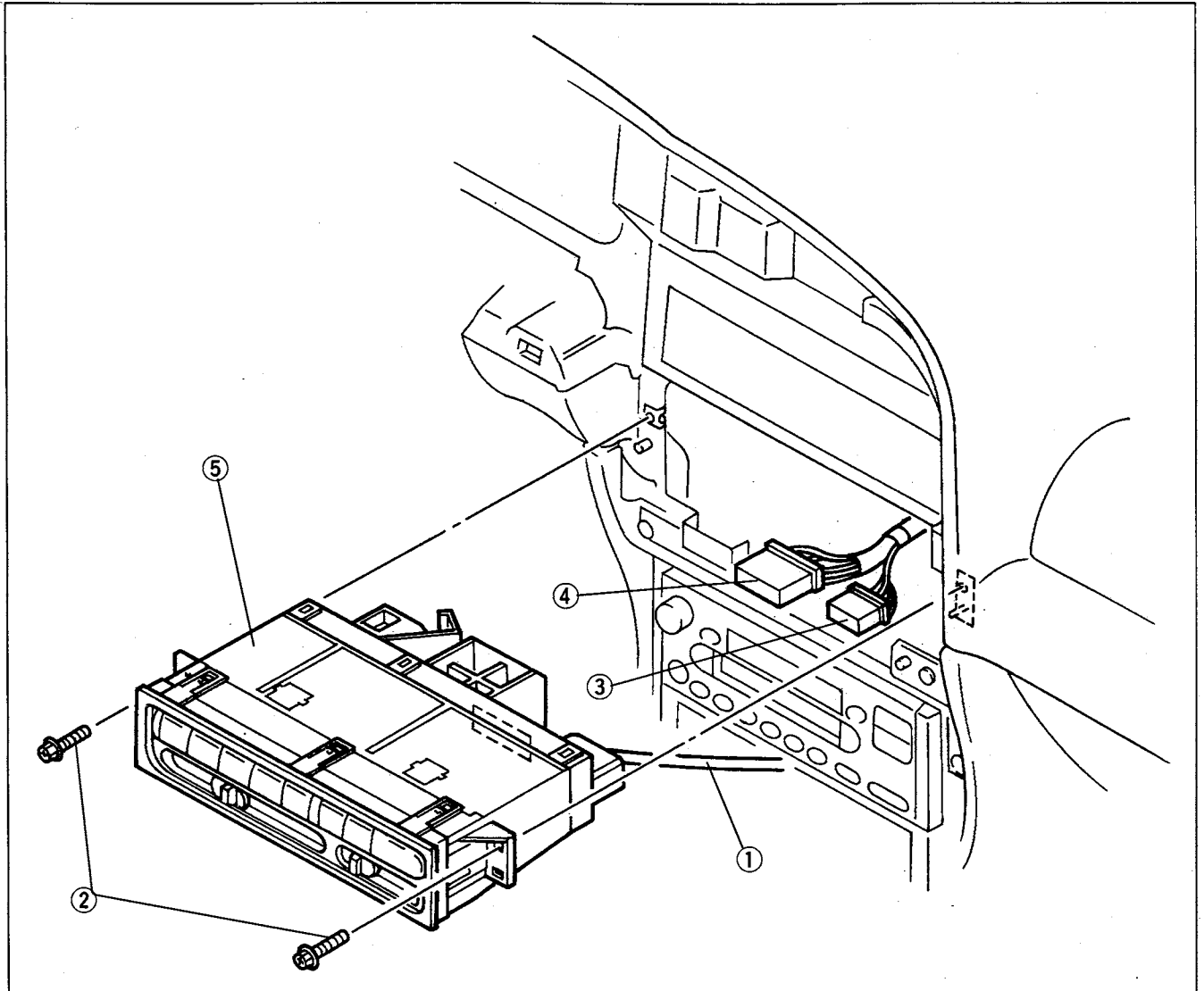

1. Air mix wire
Wire adjustment page U-38
2. Screw
3. Fan switch connector

4. Heater control unit connector
5. Heater control unit
Disassembly / Assembly page U-40

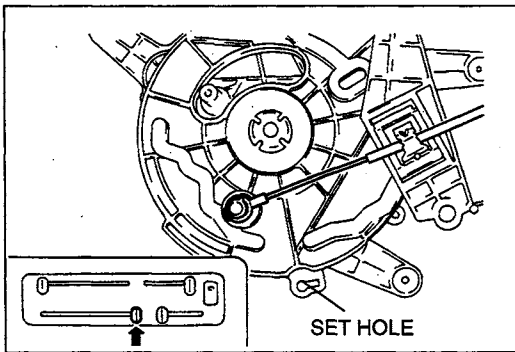

Wire Adjustment

Airflow mode wire

1. Set the MODE lever at DEFROSTER.
2. Connect the airflow mode wire to the airflow mode main link.
3. Set the airflow mode main link to DEFROSTER and insert a screwdriver ($\phi 5$) into the set hole. Clamp the airflow mode wire.
4. Verify that the MODE lever moves in its full stroke.

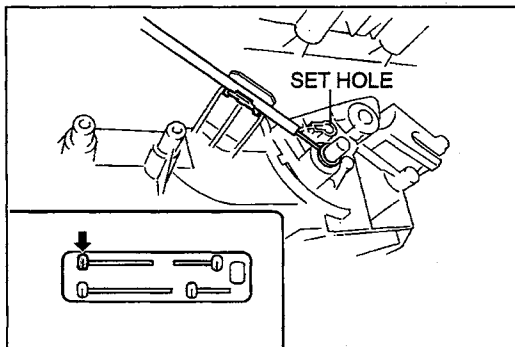

Air mix wire

1. Set the temperature control lever at MAX COLD.
2. Connect the air mix wire to the air mix link.
3. Set the air mix link to MAX COLD and insert a screwdriver ($\phi 5$) into the set hole. Clamp the air mix wire.
4. Verify that the temperature control lever moves in its full stroke.

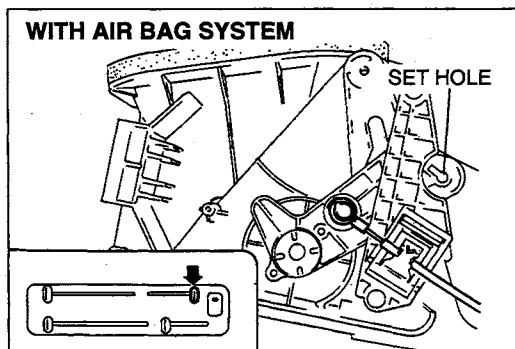

Air intake wire

1. Set the REC/FRESH lever at FRESH.
2. Connect the air intake wire to the air intake link.
3. Set the air intake link to FRESH and insert a screwdriver ($\phi 5$) into the set hole. Clamp the air intake wire.
4. Verify that the REC/FRESH lever moves in its full stroke.

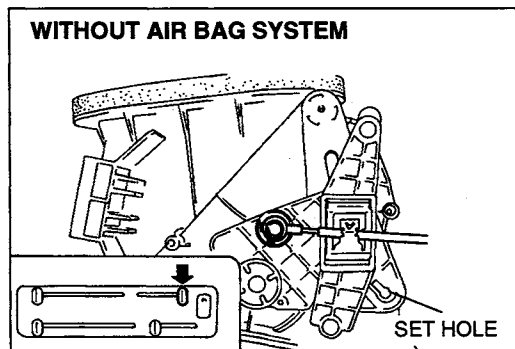

Disassembly / Assembly

1. Disassemble in the order shown in the figure.
2. Assemble in the reverse order of removal.

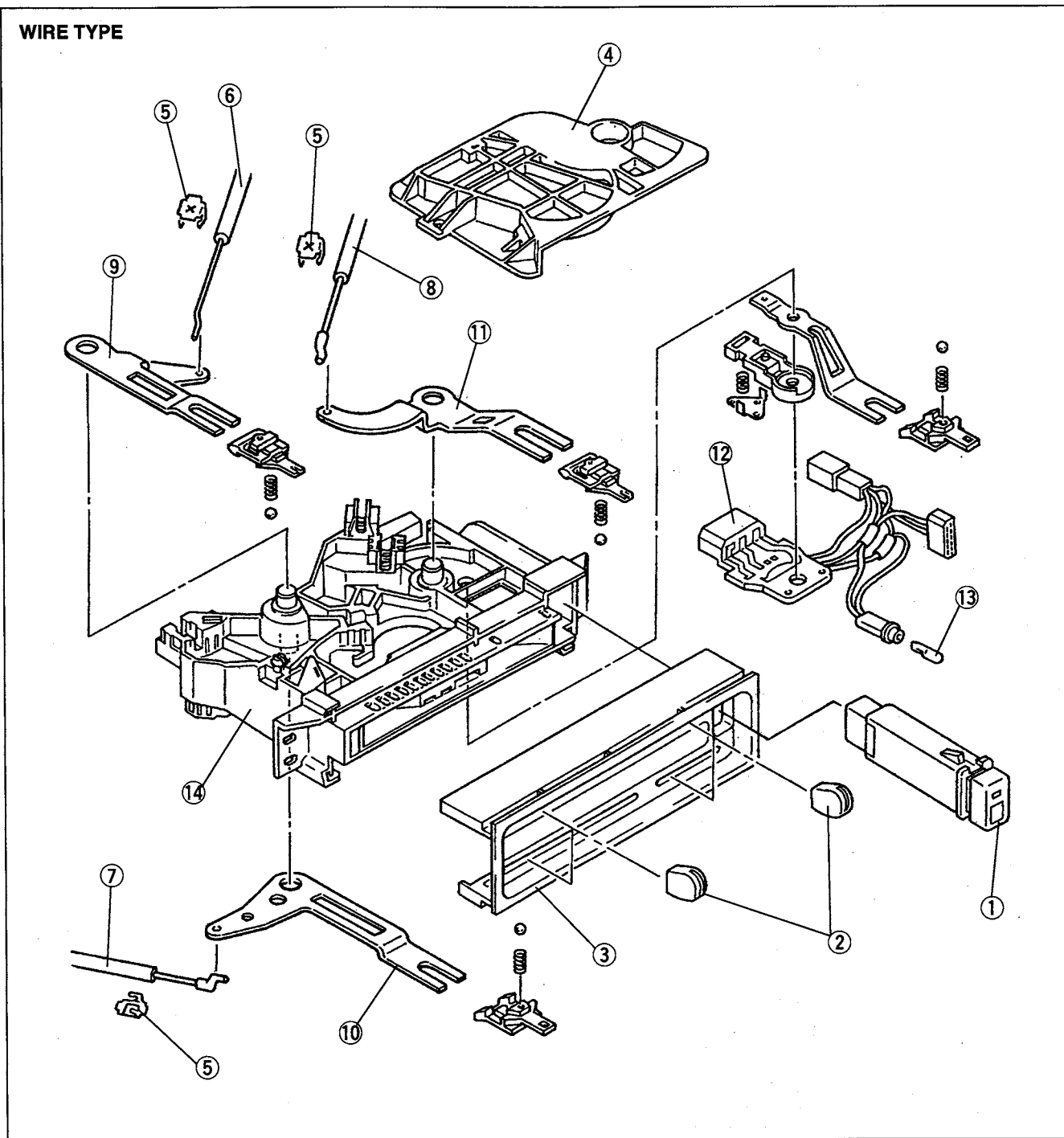

1. A/C switch
Inspection page U-42
2. Knobs
3. Switch panel
4. Cover
5. Clip
6. Air mix wire
7. Airflow mode wire

8. Air intake wire
9. Temperature control lever
10. MODE lever
11. REC/FRESH lever
12. Fan switch
Inspection page U-41
13. Bulb
14. Switch body

LOGIC TYPE

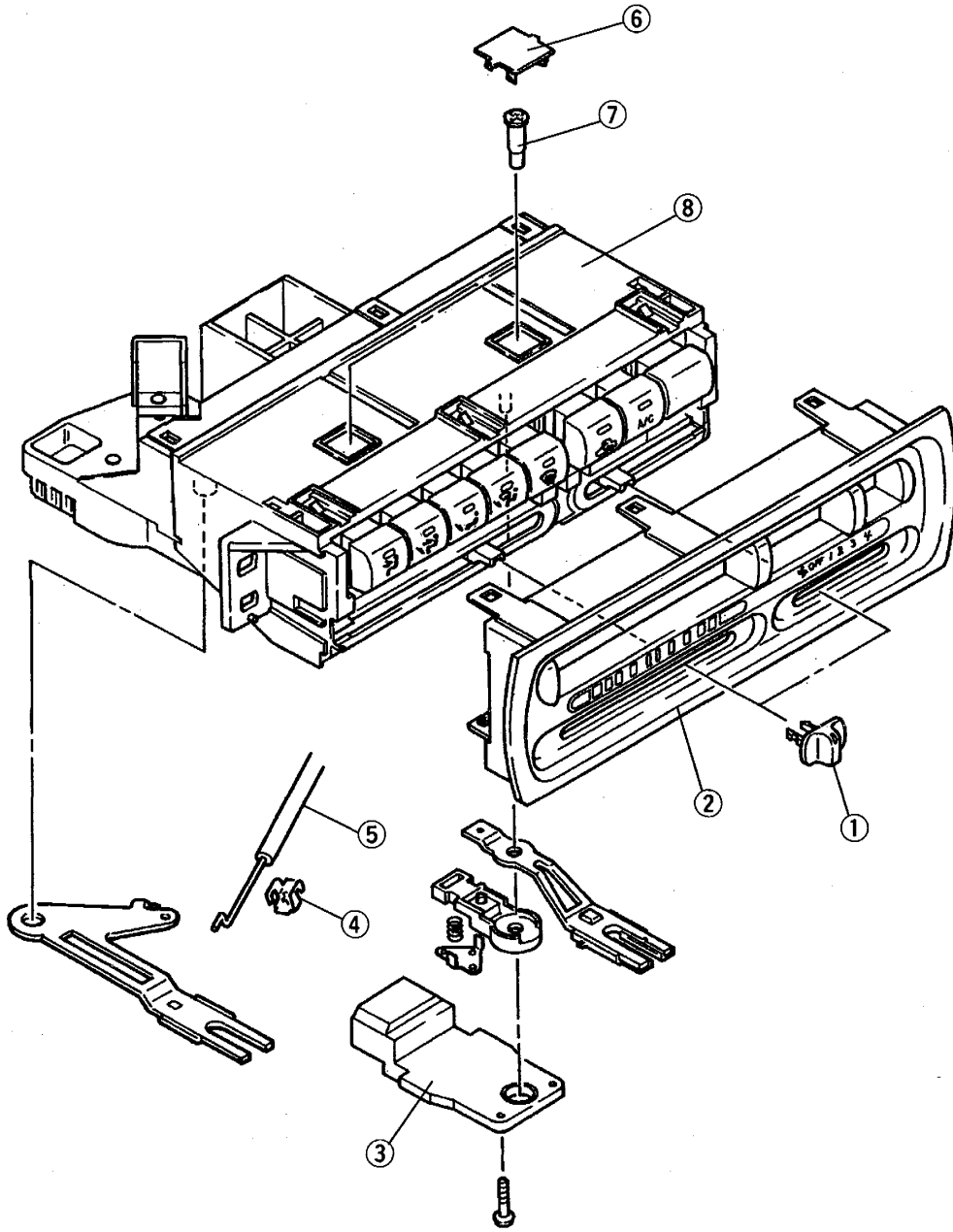

- 1. Knob
- 2. Switch panel
- 3. Fan switch
Inspection page U-41
- 4. Clip

- 5. Air mix wire
- 6. Cover
- 7. Bulb
- 8. Switch body
Inspection page U-42

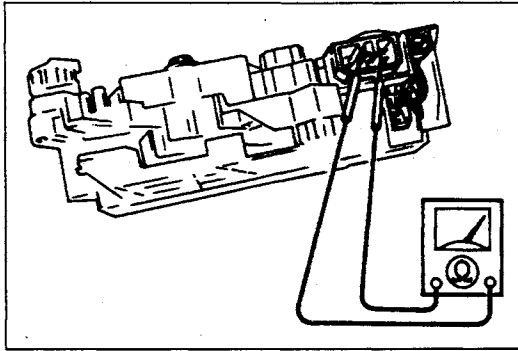

Inspection
Fan switch
Wire type

1. Check for continuity between the terminals of the fan switch.
2. If not as specified, replace the fan switch.

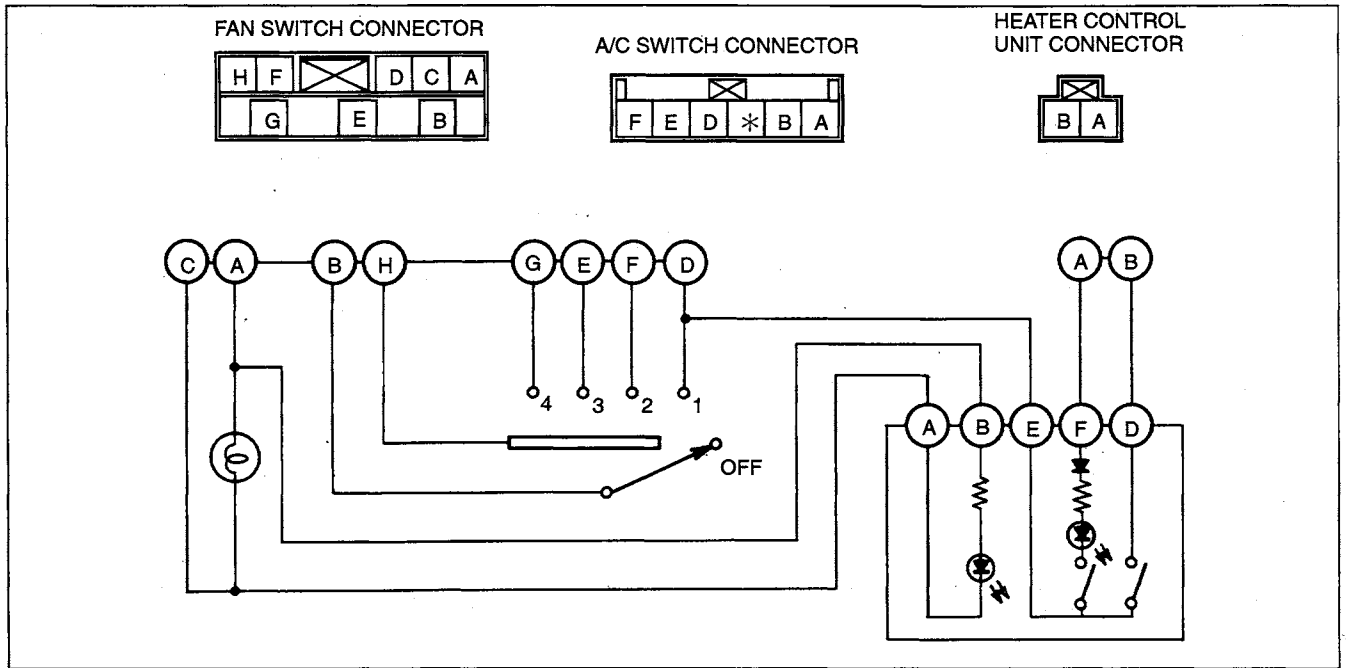

○—○: Continuity

Terminal Switch position	Fan switch								A/C switch					Heater control unit	
	A	B	C	D	E	F	G	H	A	B	D	E	F	A	B
Constant	○		○	○					○	○	○	○	○	○	○
OFF															
1		○		○											
2		○				○		○							
3		○				○		○							
4		○						○							

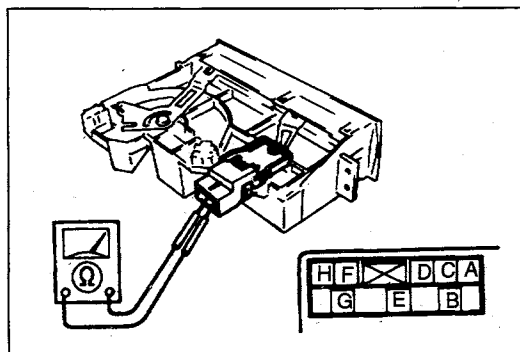

Logic type

1. Check for continuity between the terminals of the fan switch.

○—○: Continuity

Terminal Switch position	B	D	E	F	G	H
OFF						
1	○	○				
2	○			○		○
3	○		○			○
4	○				○	○

2. If not as specified, replace the fan switch.

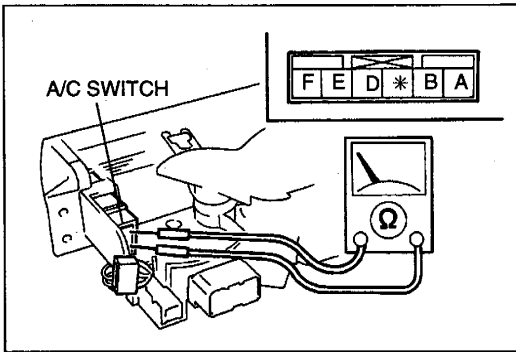

A/C switch (wire type)

1. Check for continuity between the terminals of the A/C switch.

○—○: Continuity

A/C switch	D	E
OFF		
ON	○—○	○—○

2. Turn the A/C switch on.
3. Connect battery positive voltage and ground to the terminals of the A/C switch.

B+: Battery positive voltage

B+	GND
B	A
F	E

4. Verify that the light-emitting diode illuminates.
5. If not as specified, replace the A/C switch.

Switch body (logic type)

Preparation

Connect battery positive voltage to terminal F and ground to terminal J.

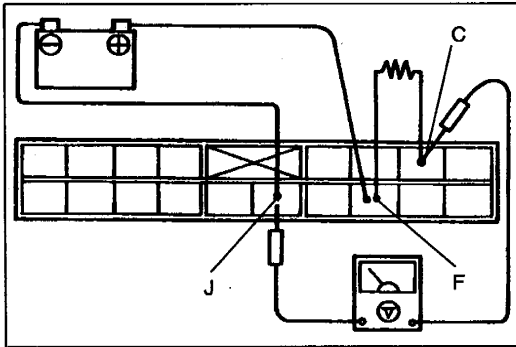

REC switch

1. Connect a 1 kΩ resistor between terminals C and F.
2. Turn the REC switch on, and measure the voltage between terminals C and J.

B+: Battery positive voltage

REC switch	Voltage
ON	1 V or less
OFF	B+

3. If not as specified, replace the heater control unit.

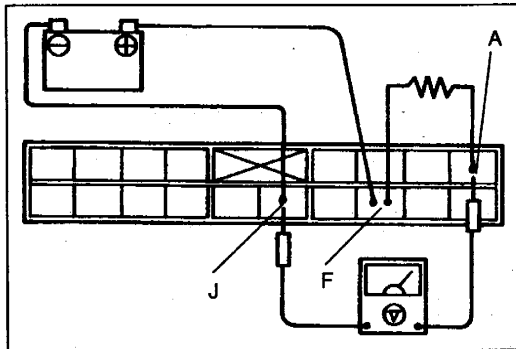

4. Connect a 1 kΩ resistor between terminals A and F.
5. Turn the REC switch off, and measure the voltage between terminals A and J.

B+: Battery positive voltage

REC switch	Voltage
OFF	1 V or less
ON	B+

6. If not as specified, replace the heater control unit.

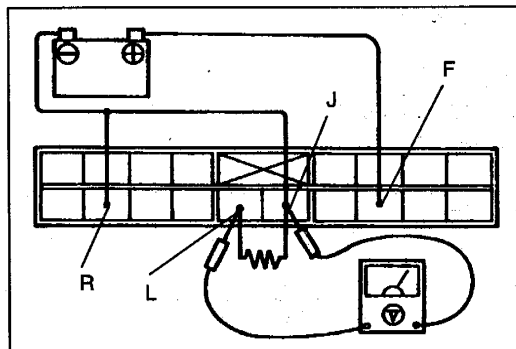

MODE switch

1. Connect a 1 kΩ resistor between terminals J and L.
2. Connect a jumper wire between terminals J (or negative battery terminal) and R.
3. Measure the voltage between terminals J and L.

B+: Battery positive voltage

Terminal	Voltage
J—L	B+

4. If not as specified, replace the heater control unit.

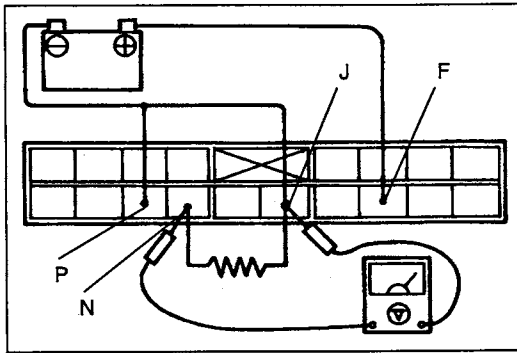

5. Connect a 1 kΩ resistor between terminals J and N.
6. Connect a jumper wire between terminals J (or negative battery terminal) and P.
7. Measure the voltage between terminals J and N.

B+: Battery positive voltage

Terminal	Voltage
J — N	B+

8. If not as specified, replace the heater control unit.

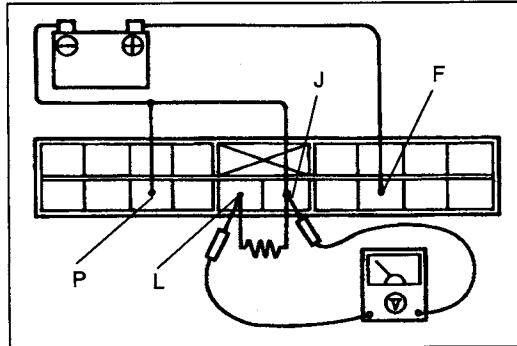

9. Connect a 1 kΩ resistor between terminals J and L.
10. Connect a jumper wire between terminals J (or negative battery terminal) and P.
11. Measure the voltage between terminals J and L.

Terminal	Voltage
J — L	1 V or less

12. If not as specified, replace the heater control unit.

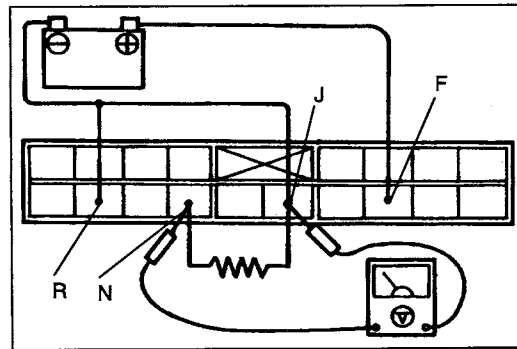

13. Connect a 1 kΩ resistor between terminals J and N.
14. Connect a jumper wire between terminals J (or negative battery terminal) and R.
15. Measure the voltage between terminals J and N.

Terminal	Voltage
J — N	1 V or less

16. If not as specified, replace the heater control unit.

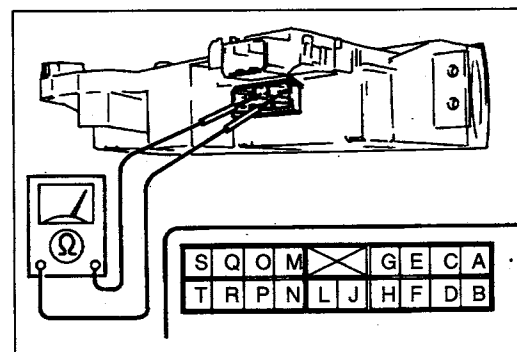

17. Check for continuity between the following terminals while pressing the MODE switches.

○—○: Continuity

Terminal Switch	J	T	S	Q	O	M
VENT	○—○					
BI-LEVEL	○—○		○			
HEAT	○—○			○		
HEAT/DEF	○—○				○	
DEFROSTER	○—○					○

18. If not as specified, replace the heater control unit.

A/C switch (if equipped)

1. Check for continuity between terminals B and D while pressing the A/C switch.

○—○: Continuity

A/C switch	Terminal	B	D
OFF			
ON		○—○	

2. If not as specified, replace the heater control unit.

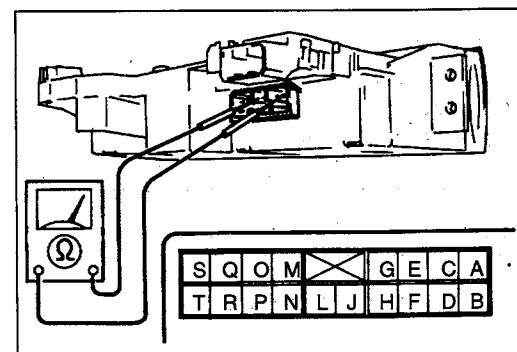

TROUBLESHOOTING

TROUBLESHOOTING NOTES

- Precise understanding of customer complaints is the key to diagnosing problems.
- Diagnosis of air conditioning system problems can be difficult because of the surrounding temperatures. Therefore, checking the system operation is important. Further checking the system operation in a logical order is necessary for the accurate understanding of problems.

USING THIS SECTION

When troubleshooting, follow the procedure shown below.

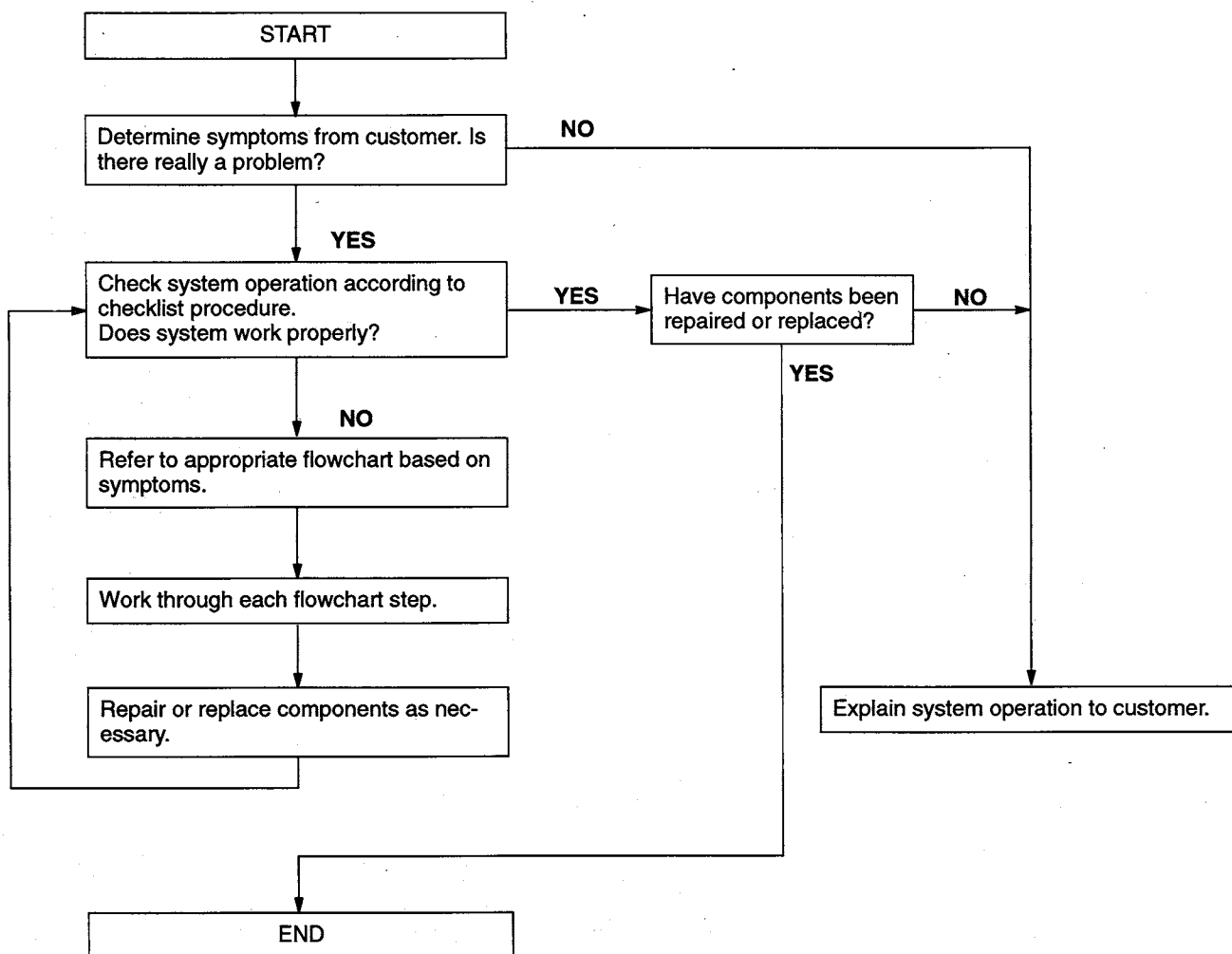

- Note the following points when using the flowcharts.

Flowchart No. 5	A/C signal system inspection	Symptom.....Magnetic clutch, condenser fan, and A/C compressor idle-up do not operate Related parts...A/C amplifier, refrigerant pressure switch, heater control unit, PCM, wiring harness.
---------------------------	------------------------------	--

Step	Inspection procedure	Terminal	Result	Action
				B+: Battery positive voltage
3	1) Connect jumper wire between terminal B or C of A/C amplifier connector (female) and ground. 2) Verify that temperature around evaporator temperature sensor is 3.5°C (38.3°F) or more. 3) Start engine. 4) Do magnetic clutch and condenser fan operate?	Jumper wire between terminal B and ground Jumper wire between terminal C and ground	YES YES NO	Disconnect jumper wire from terminal B and connect to terminal C. Repair wiring harness [Refrigerant pressure switch-A/C amplifier:A-B] Remove jumper wire and go to Step 4 Check A/C amplifier (Refer to page U-36)
4	Measure voltage at terminal of heater control unit connector (female: 16-pin).	2 D	B+ Other	Go to step 5 Repair wiring harness [A/C amplifier-heater control unit:C-2D]
5	1) Turn the ignition switch to OFF. 2) Disconnect midway connector (X-26). 3) Is there continuity between terminals of heater control unit connector (female: 16-pin) and midway connector (female)?	2 E - A	YES NO	Replace heater control unit (Refer to page U-34) Repair wiring harness [Heater control unit -midway connector: 2E-A]

- Only those parts, connectors, and harnesses that are directly related to the item being checked are indicated in the wiring diagram.
- Follow the steps in order when troubleshooting the system.
- Before inspection, turn all switches to OFF. When moving from step to step, keep the switches, connectors, and jumper wire in their former position unless otherwise instructed.
Before connecting or disconnecting a jumper wire, turn the ignition switch to LOCK to prevent burning the electrical parts. After the jumper wire is connected or disconnected, the ignition switch can be turned to ON again.
- When checking for continuity of the wiring harness, the terminal names are shown under "Terminal" and their corresponding connector names are shown under "Inspection procedure." When repairing the wiring harness, the terminal names and the corresponding part names to which they are connected are shown under "Action."

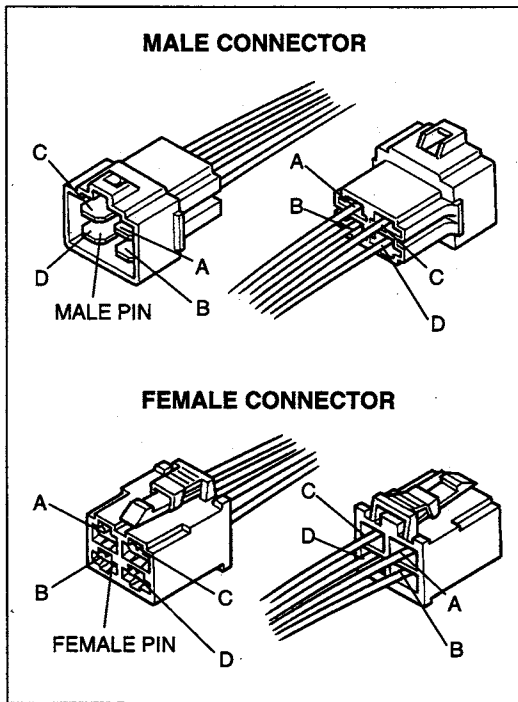

5. Inspect connectors from either the male or female side stated after the connector name.

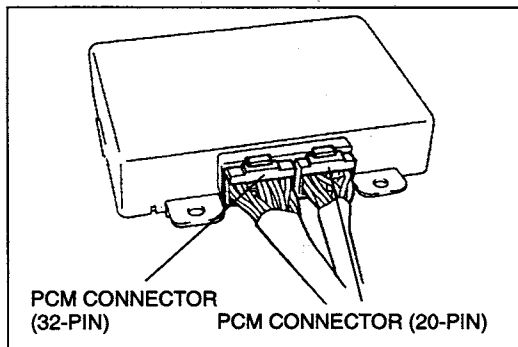

6. When more than one connector is attached to the same part, the pin number enclosed in () after the connector name distinguishes the connectors. The wiring diagram connector number shown before alphabet letter distinguishes the terminals.

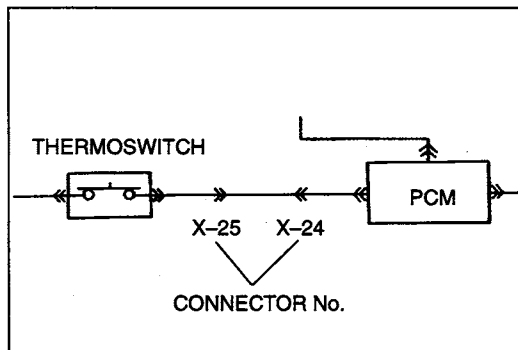

7. When more than one harness connects two different parts, the wiring diagram connector number enclosed in () after the connector name distinguishes the connectors.

TROUBLESHOOTING

Checklists

Determine symptoms of the problem based on the customer's complaints. Refer to the fuse checklist and match the symptoms obtained from the customer with those listed in the table. Check the appropriate fuse. If the fuse is OK, operate the system. Determine the general area of the problem; for example, airflow, idle-up, or temperature.

Look at the main checklist and locate the general problem area (first column). Follow each step of the instructions for the specific system (second column). If the system does not operate properly (third column), determine the symptoms and corresponding flowchart number (fourth and fifth columns). Refer to the appropriate flowchart and troubleshoot the system.

Fuse checklist

Symptom	Related fuse
Entire control system does not operate	A/C 10 A (fuse block)
Blower motor does not operate	HEATER 40 A
Condenser fan does not operate	AD FAN 30 A
A/C compressor idle-up operates, but magnetic clutch and condenser fan do not operate	TURN 10 A
Magnetic clutch does not operate	A/C 10 A (main fuse block)

Main checklist

Start and warm up the engine so that the engine coolant temperature reaches 40—100 °C { 104—212 °F }. Keep the engine running while doing the procedures.

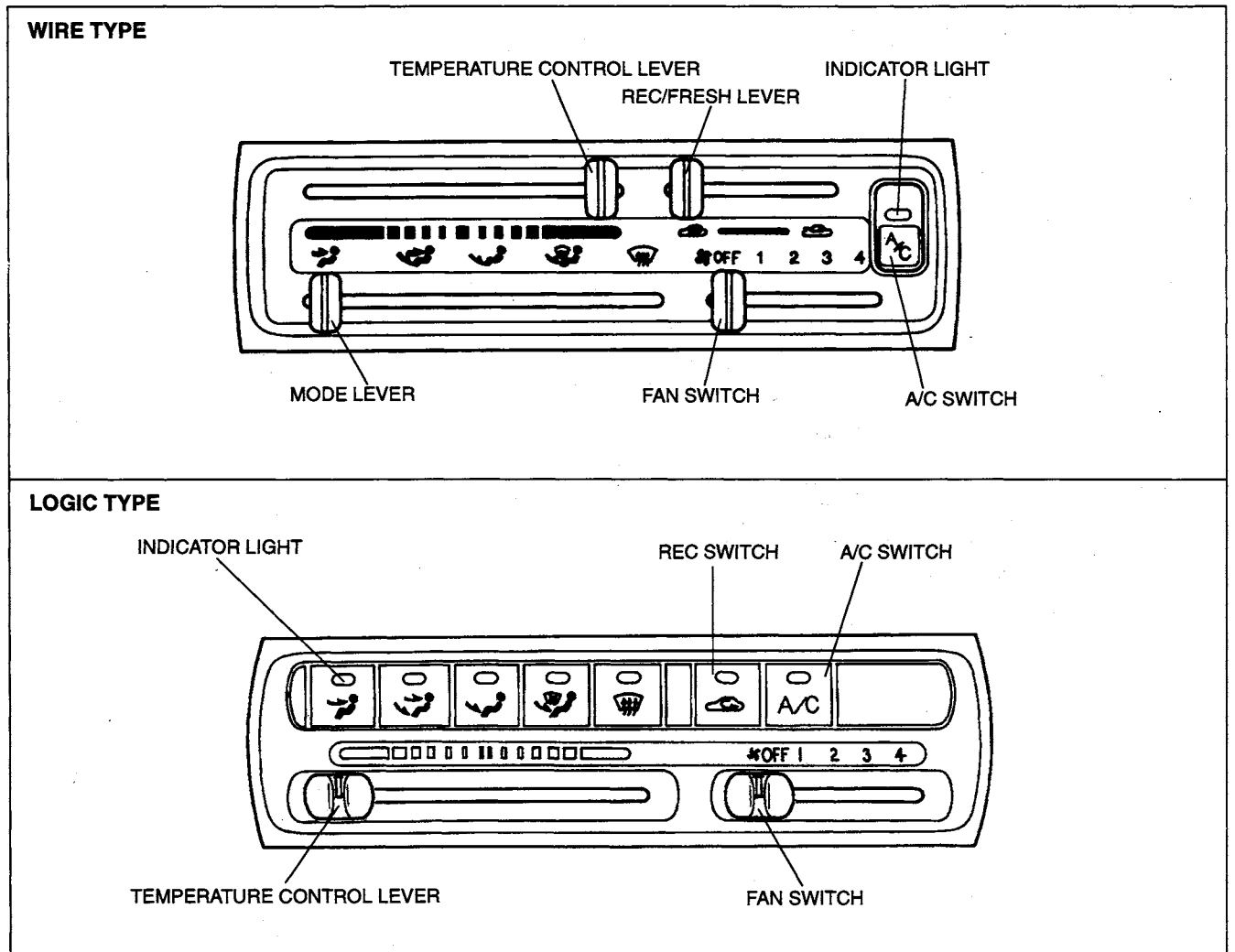

General problem area	Procedure	Proper operation	Symptom	Flowchart No. (Reference)
Entire control system	(Wire type) Operate fan switch and A/C switch.	Following control system parts operate when switches are operated: <ul style="list-style-type: none"> • Indicator light of A/C switch • Blower motor • Magnetic clutch • Condenser fan 	Control system does not operate and illuminate	1 (page U-50)
	(Logic type) Operate fan switch, REC switch, MODE switch, and A/C switch.	Following control system parts operate when switches are operated: <ul style="list-style-type: none"> • Indicator light of each switch • Blower motor • Air intake actuator • Airflow mode actuator • Magnetic clutch • Condenser fan 	Control system does not operate and illuminate	1 (page U-50)
			Airflow mode actuator does not operate and indicator light of each switch does not illuminate	2 (page U-50)
			Each actuator does not operate and indicator light of each switch does not illuminate	3 (page U-50)
Air outlet volume system	Set fan switch in order at 1st, 2nd, 3rd, and 4th.	Blower motor operates according to fan switch operation	Blower motor does not operate	6 (page U-51)
			Blower motor does not operate properly with fan switch at 1st, 2nd, 3rd, or 4th	7 (page U-52)
Air intake mode system	(Wire type) 1. Set fan switch at 4th. 2. Set REC/FRESH lever in order at each air intake mode.	Air intake wire (air intake mode) operates (changes) according to REC/FRESH lever operation	Air intake mode does not change	Wire adjustment (page U-38)
	(Logic type) 1. Set fan switch at 4th. 2. Set REC switch in order at each air intake mode.	Air intake actuator (air intake mode) operates (changes) according to REC switch operation	Air intake actuator does not operate	8 (page U-53)
Airflow mode system	(Wire type) 1. Set fan switch at 4th. 2. Set MODE lever in order at each airflow mode.	Airflow mode wire (airflow mode) operates (changes) according to MODE lever operation	Airflow mode does not change	Wire adjustment (page U-38)
	(Logic type) 1. Set fan switch at 4th. 2. Set MODE switch in order at each airflow mode.	Airflow mode actuator (airflow mode) operates (changes) according to MODE switch operation	Airflow mode actuator does not operate properly	9 (page U-54)
Electrical load idle-up system	Set fan switch in order at 1st, 2nd, 3rd, and 4th. (Electrical load should be blower motor only.)	Electrical load idle-up operates with fan switch at 2nd, 3rd, and 4th	Electrical load idle-up does not operate with fan switch at 2nd, 3rd, and/or 4th	4 (page U-50)

TROUBLESHOOTING

General problem area	Procedure	Proper operation	Symptom	Flowchart No. (Reference)
Air outlet temperature system	1. Set fan switch at 4th. 2. Change temperature control lever from MAX COLD to MAX HOT.	Air mix wire (air outlet temperature) operates (changes) according to temperature control lever	Air outlet temperature does not change	Wire adjustment (page U-38)
	3. Turn A/C switch on.	Magnetic clutch, condenser fan, and A/C compressor idle-up operate	Magnetic clutch, condenser fan, and A/C compressor idle-up do not operate	10 (page U-55)
			A/C compressor idle-up operates, but magnetic clutch and condenser fan do not operate	5 (page U-50)
			Only magnetic clutch does not operate	11 (page U-57)
			Only condenser fan does not operate	12 (page U-58)
			Magnetic clutch, condenser fan, and A/C compressor idle-up operate, but cool air does not discharged or air cooling ability is low	13 (page U-59)

Flowcharts

Flowchart No.	A/C main power source system inspection	Symptom	Control system does not operate and illuminate
1		Related parts	Wiring harness

Remedy

(Wire type)

Repair the wiring harness [Fuse—A/C amplifier: A/C 10 A—A].

(Logic type)

Repair the wiring harness [Fuse—Heater control unit: A/C 10 A—F].

Flowchart No.	Heater control unit power source system inspection (logic type only)	Symptom	Airflow mode actuator does not operate and indicator light of each switch does not illuminate
2		Related parts	Heater control unit, wiring harness

Remedy

Check for continuity between the A/C 10 A fuse and terminal F of the heater control unit.

If there is continuity, replace the heater control unit. (Refer to page U-37.)

Flowchart No.	Heater control unit ground system inspection (logic type only)	Symptom	Each actuator does not operate and indicator light of each switch does not illuminate
3		Related parts	Heater control unit, wiring harness

Remedy

Check for continuity between terminal J of the heater control unit and ground.

If there is continuity, replace the heater control unit. (Refer to page U-37.)

Flowchart No.	Electrical load idle-up system inspection	Symptom	Electrical load idle-up does not operate with fan switch at 2nd, 3rd, and/or 4th
4		Related parts	Fan switch, PCM, wiring harness

Remedy

Check the following parts. Repair or replace any abnormal parts.

1. Wiring harness [PCM—Fan switch: 1P—H]
2. Fan switch (Refer to page U-41)
3. Terminal 1P of PCM (Refer to section F1 or F2)

Flowchart No.	A/C power source system inspection	Symptom	A/C compressor idle-up operates, but magnetic clutch and condenser fan do not operate
5		Related parts	PCM (BP MTX, Z5 MTX), wiring harness

Remedy

(BP MTX, Z5 MTX)

Check the following parts. Repair or replace any abnormal parts. If the parts are normal, check the PCM, (Refer to section F1 or F2.)

1. Wiring harness [Fuse—A/C relay: TURN 10 A—A]
2. Wiring harness [A/C relay—PCM: B—1G]

(BP ATX, Z5 ATX)

Repair the wiring harness [Fuse—A/C relay: TURN 10 A—A].

Flowchart No.	Blower motor system inspection	Symptom Blower motor does not operate
6		Related parts . . . Blower motor, blower relay, fan switch, wiring harness

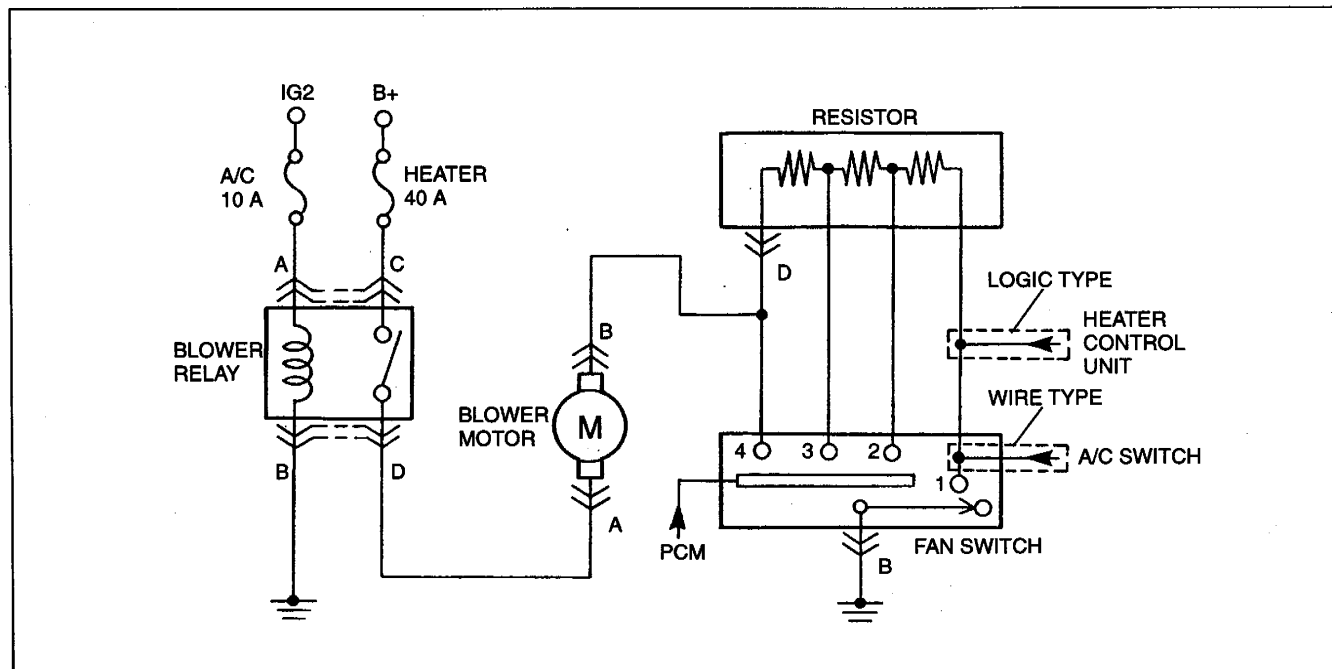

B+: Battery positive voltage

Step	Inspection procedure	Terminal	Result	Action
1	1) Turn ignition switch to ON. 2) Measure voltage at terminal of resistor connector (female).	D	B+	Go to Step 4
			Other	Go to Step 2
2	Measure voltage at terminals of blower motor connector (female).	A	B+	Check terminal B
			Other	Go to Step 3
		B	B+	Repair wiring harness [Blower motor — Resistor: B—D]
			Other	Replace blower motor (Refer to page U-32)
3	Measure voltage at terminals of blower relay connector (female).	D	B+	Repair wiring harness [Blower relay — Blower motor: D—A]
			Other	Check terminal C
		C	B+	Check terminal A
			Other	Repair wiring harness [Fuse—Blower relay: HEATER 40 A—C]
		A	B+	Check terminal B
			Other	Repair wiring harness [Fuse—Blower relay: A/C 10 A—A]
		B	B+	Repair wiring harness [Blower relay (B)—GND]
			Other	Replace blower relay (Refer to page U-31)
4	1) Turn ignition switch to LOCK. 2) Disconnect fan switch connector. 3) Is there continuity between terminal of fan switch connector (female) and ground?	B—Ground	YES	Replace fan switch (Refer to page U-39 or U-40)
			NO	Repair wiring harness [Fan switch (B)—GND]

Flowchart No. 7	Fan switch system inspection	Symptom Blower motor does not operate properly with fan switch at 1st, 2nd, 3rd, or 4th
		Related parts ... Resistor, fan switch, wiring harness

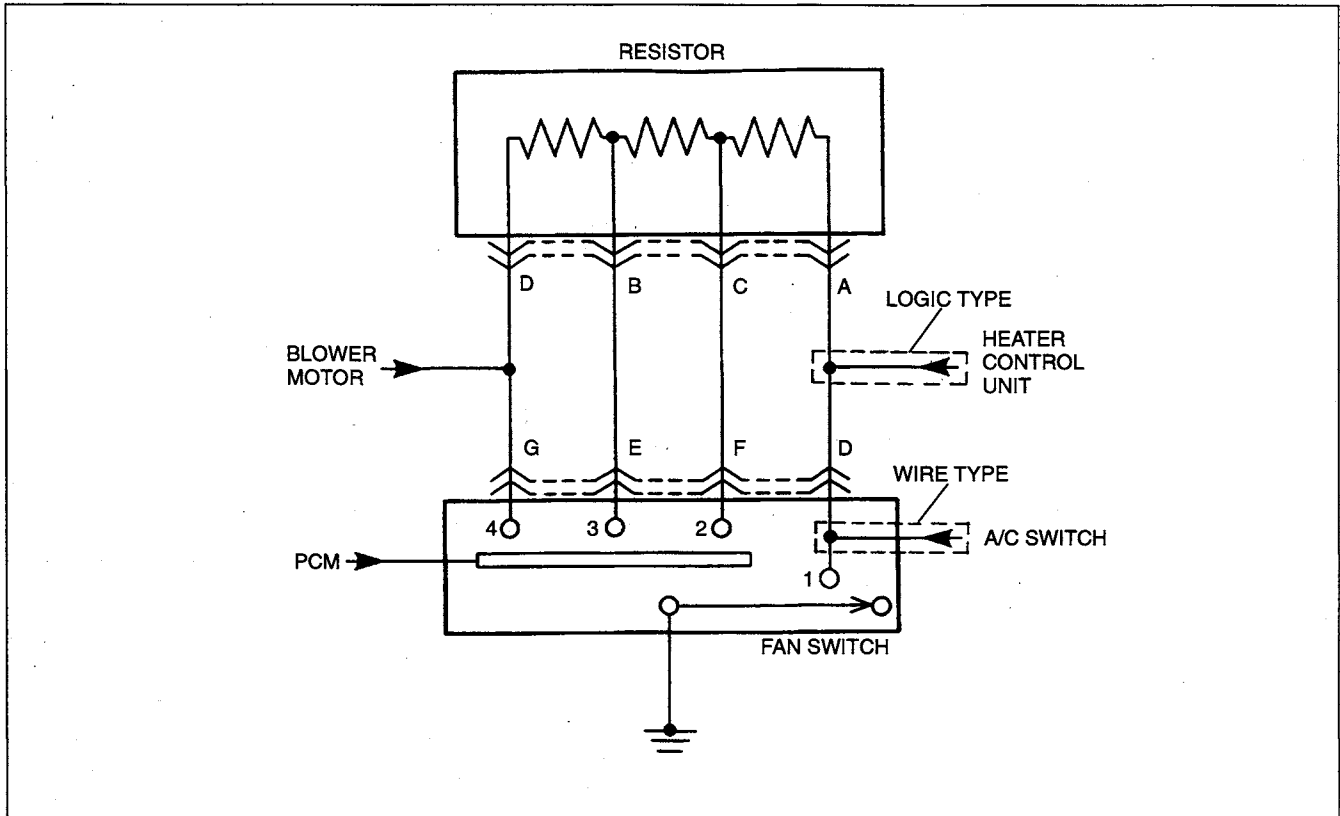

B+: Battery positive voltage

Step	Inspection procedure	Terminal	Result	Action
1	1) Turn ignition switch to ON. 2) Measure voltage at terminals of resistor connector (female).	D	B+	Check terminals A, B and C
			Other	Repair wiring harness [Blower motor—Resistor: B—D]
		A, B, C	B+ (all)	Go to Step 2
			Other (Portion)	Replace resistor (Refer to page U-32)
2	Measure voltage at terminals of fan switch connector (female).	G	B+	Check terminal E
			Other	Repair wiring harness [Resistor—Fan switch: D—G]
		E	B+	Check terminal F
			Other	Repair wiring harness [Resistor—Fan switch: B—E]
		F	B+	Check terminal D
			Other	Repair wiring harness [Resistor—Fan switch: C—F]
		D	B+	Replace fan switch (Refer to page U-39 or U-40)
			Other	Repair wiring harness [Resistor—Fan switch: A—D]

Flowchart No.	Air intake actuator system inspection (logic type only)	Symptom Air intake actuator does not operate
8		Related parts . . . Blower unit, air intake actuator, heater control unit, wiring harness

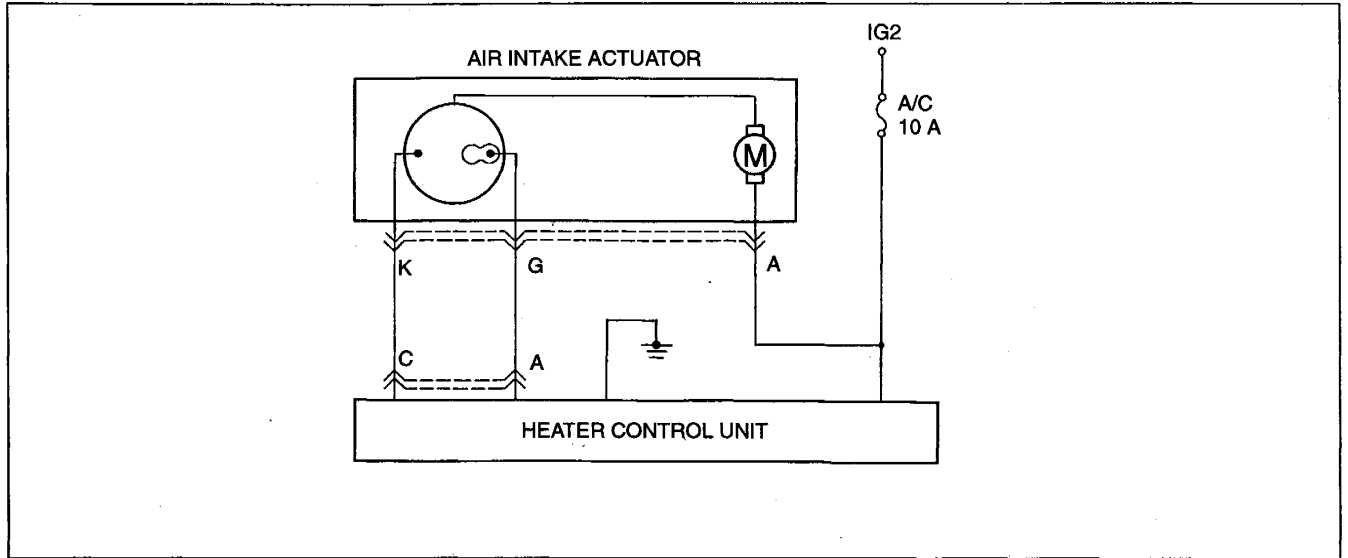

B+: Battery positive voltage

Step	Inspection procedure	Terminal	Result	Action
1	1) Remove air intake actuator. (Refer to page U-33.) 2) Turn ignition switch to ON. 3) Set fan switch at 4th. 4) Operate air intake crank by hand. 5) Does air intake mode change smoothly from RECIRCULATE to FRESH?	—	YES	Go to Step 2
			NO	Check blower unit
2	1) Turn fan switch off. 2) Measure voltage at terminal of air intake actuator connector (female).	A	B+	Go to Step 3
			Other	Repair wiring harness [Fuse—Air intake actuator: A/C 10 A—A]
3	1) Turn ignition switch to LOCK. 2) Turn REC switch on. 3) Is there continuity between terminal of air intake actuator connector (female) and ground?	K—ground	YES	Go to Step 4
			NO	Go to Step 5
4	1) Turn REC switch off. 2) Is there continuity between terminal of air intake actuator connector (female) and ground?	G—ground	YES	Replace air intake actuator (Refer to page U-33)
			NO	Go to Step 5
5	1) Disconnect heater control unit connector. 2) Is there continuity between terminals of air intake actuator connector (female) and heater control unit connector (female)?	G—A K—C	YES (all)	Replace heater control unit (Refer to page U-37)
			NO (partial)	Repair wiring harness that has no continuity (Air intake actuator—Heater control unit)

Flowchart No.	Airflow mode actuator system inspection (logic type only)	Symptom Airflow mode actuator does not operate properly
9		Related parts ... Heater unit, airflow mode actuator, heater control unit, wiring harness

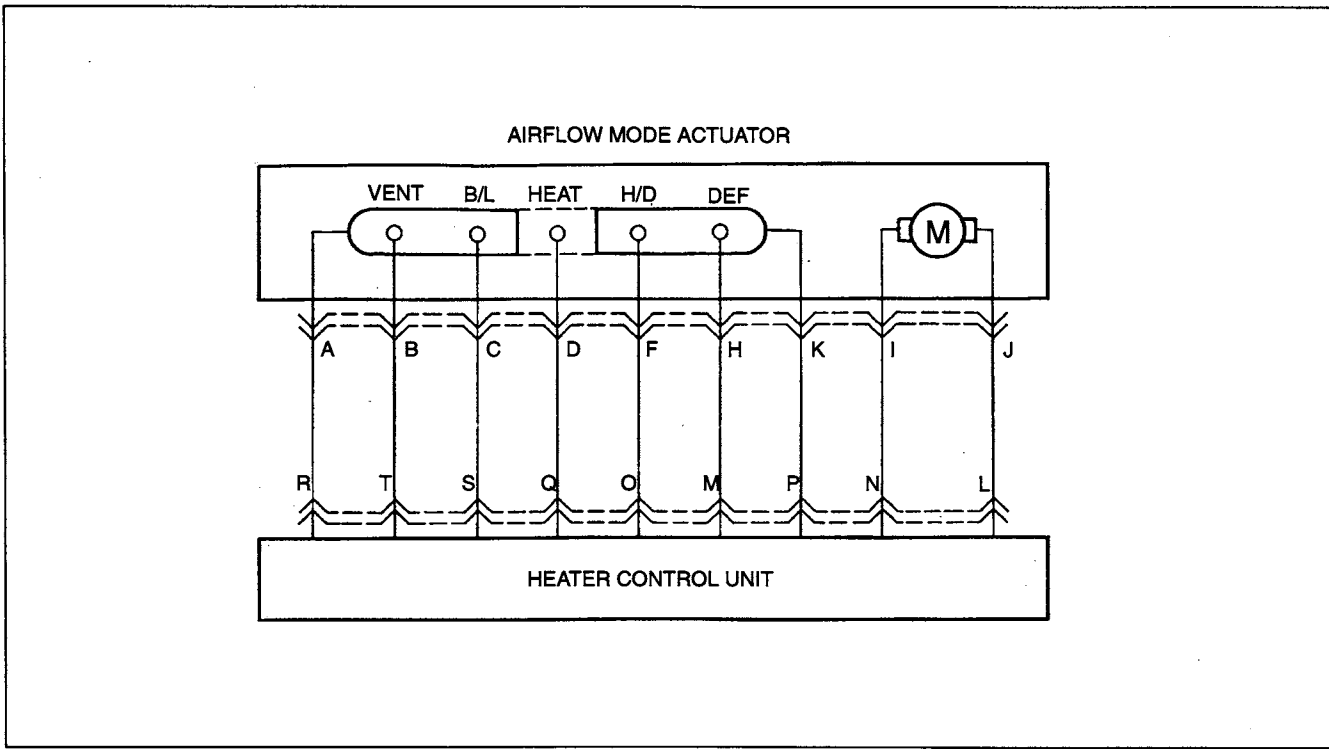

Step	Inspection procedure	Terminal	Result	Action
1	1) Remove airflow mode actuator. (Refer to page U-33.) 2) Turn ignition switch to ON. 3) Set fan switch at 4th. 4) Operate airflow mode main link by hand. 5) Does airflow mode change smoothly to VENT, BI-LEVEL, HEAT, HEAT/DEF, and DEFROSTER?	—	YES	Go to Step 2
			NO	Check heater unit
2	1) Check airflow mode actuator. (Refer to page U-33.) 2) Does airflow mode actuator operate properly?	—	YES	Go to Step 3
			NO	Replace airflow mode actuator (Refer to page U-33)
3	1) Turn ignition switch to LOCK. 2) Disconnect heater control unit connector. 3) Is there continuity between terminals of airflow mode actuator connector (female) and heater control unit connector (female)?	J—L, I—N, K—P, H—M, F—O, D—Q, C—S, B—T, A—R	YES (all)	Replace heater control unit (Refer to page U-37)
			NO (partial)	Repair wiring harness that has no continuity (Airflow mode actuator—Heater control unit)

Flowchart No.	A/C signal system inspection	Symptom Magnetic clutch, condenser fan, and A/C compressor idle-up do not operate
10		Related parts ... PCM, refrigerant pressure switch, A/C amplifier, A/C switch (wire type), fan switch (wire type), heater control unit (logic type), wiring harness

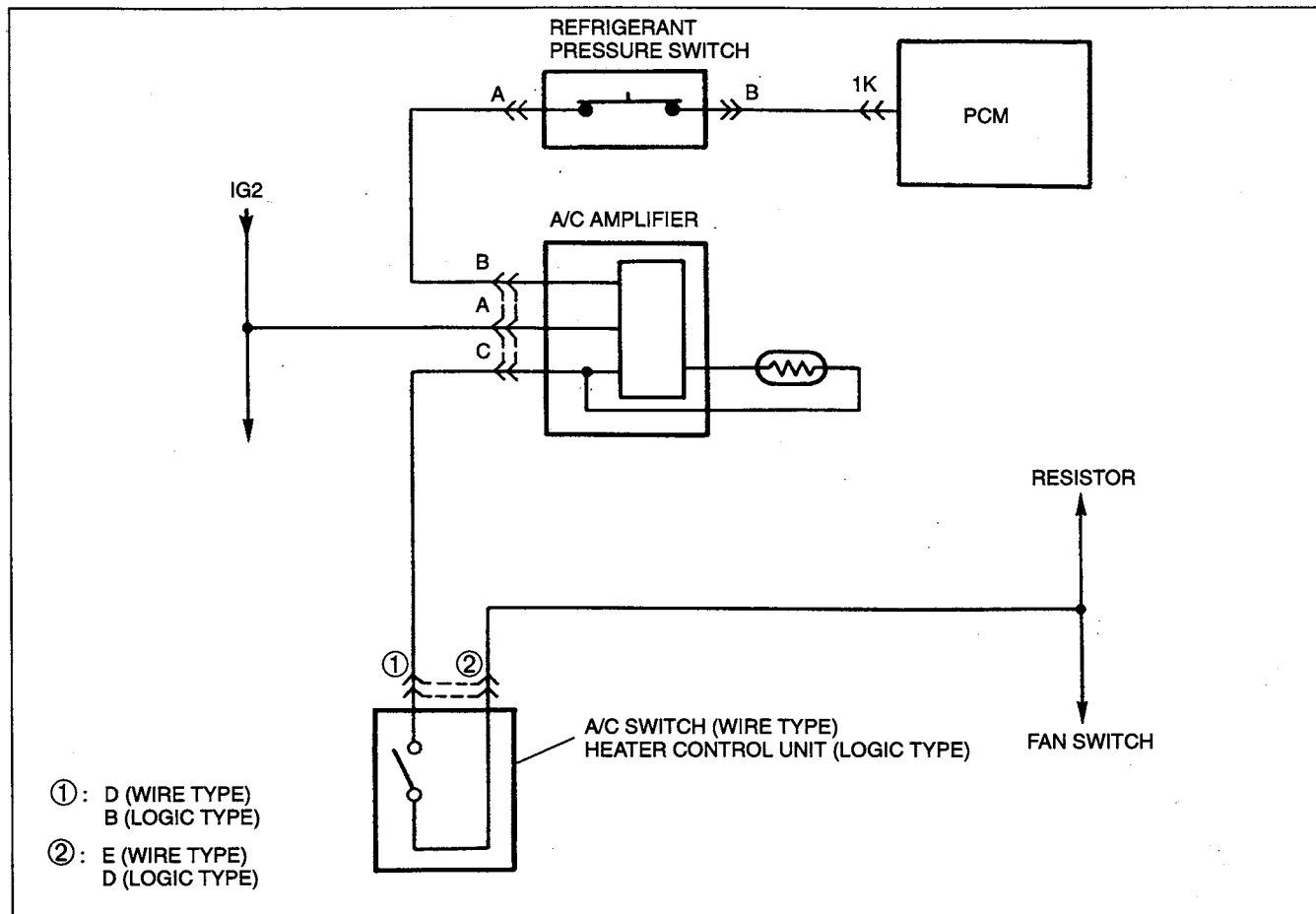

Step	Inspection procedure	Terminal	Result	Action
1	1) Disconnect refrigerant pressure switch connector. 2) Connect jumper wire between terminal B of refrigerant pressure switch connector (female) and ground. 3) Start engine. 4) Do magnetic clutch, condenser fan, and A/C compressor idle-up operate?	—	YES	Remove jumper wire and go to Step 2
			NO	Check for continuity between wiring harness of PCM and refrigerant pressure switch: [1K—B], and check PCM (Refer to section F1 or F2)
2	1) Turn ignition switch to LOCK. 2) Is there continuity between terminals of refrigerant pressure switch connector (male)?	B—A	YES	Connect refrigerant pressure switch connector and go to Step 3
			NO	Check refrigerant pressure switch (Refer to page U-31)
3	1) Connect jumper wire between terminal B or C of A/C amplifier connector (female) and ground. 2) Verify that temperature around sensor part of thermoswitch is 3.6 °C { 38 °F } or more. 3) Start engine. 4) Do magnetic clutch, condenser fan, and A/C compressor idle-up operate?	Jumper wire between terminal B and ground	YES	Disconnect jumper wire from terminal B and connect to terminal C
			NO	Repair wiring harness [Refrigerant pressure switch—A/C amplifier: A—B]
		Jumper wire between terminal C and ground	YES	Remove jumper wire and go to Step 4 (wire type) or Step 6 (logic type)
			NO	Check A/C amplifier (Refer to page U-34)

B+: Battery positive voltage

Step	Inspection procedure	Terminal	Result	Action
4	Measure voltage at terminal of A/C switch connector (female).	D	B+	Go to Step 5
			Other	Repair wiring harness [A/C amplifier—A/C switch: C—D]
5	1) Turn ignition switch to LOCK. 2) Disconnect A/C switch connector. 3) Turn A/C switch on. 4) Is there continuity between terminals of A/C switch connector (male)?	D—E	YES	Replace fan switch (Refer to page U-39)
			NO	Replace A/C switch (Refer to page U-39)
6	Measure voltage at terminal of heater control unit connector (female).	B	B+	Go to Step 7
			Other	Repair wiring harness [A/C amplifier—Heater control unit: C—B]
7	1) Turn ignition switch to LOCK. 2) Disconnect heater control unit connector. 3) Turn A/C switch on. 4) Is there continuity between terminals of heater control unit connector (male)?	B—D	YES	Repair wiring harness [Heater control unit—Fan switch: B—D]
			NO	Replace heater control unit (Refer to page U-37)

Flowchart No.	Magnetic clutch system inspection	Symptom Only magnetic clutch does not operate
11		Related parts . . . A/C relay, magnetic clutch, PCM (BP ATX, Z5 ATX), wiring harness

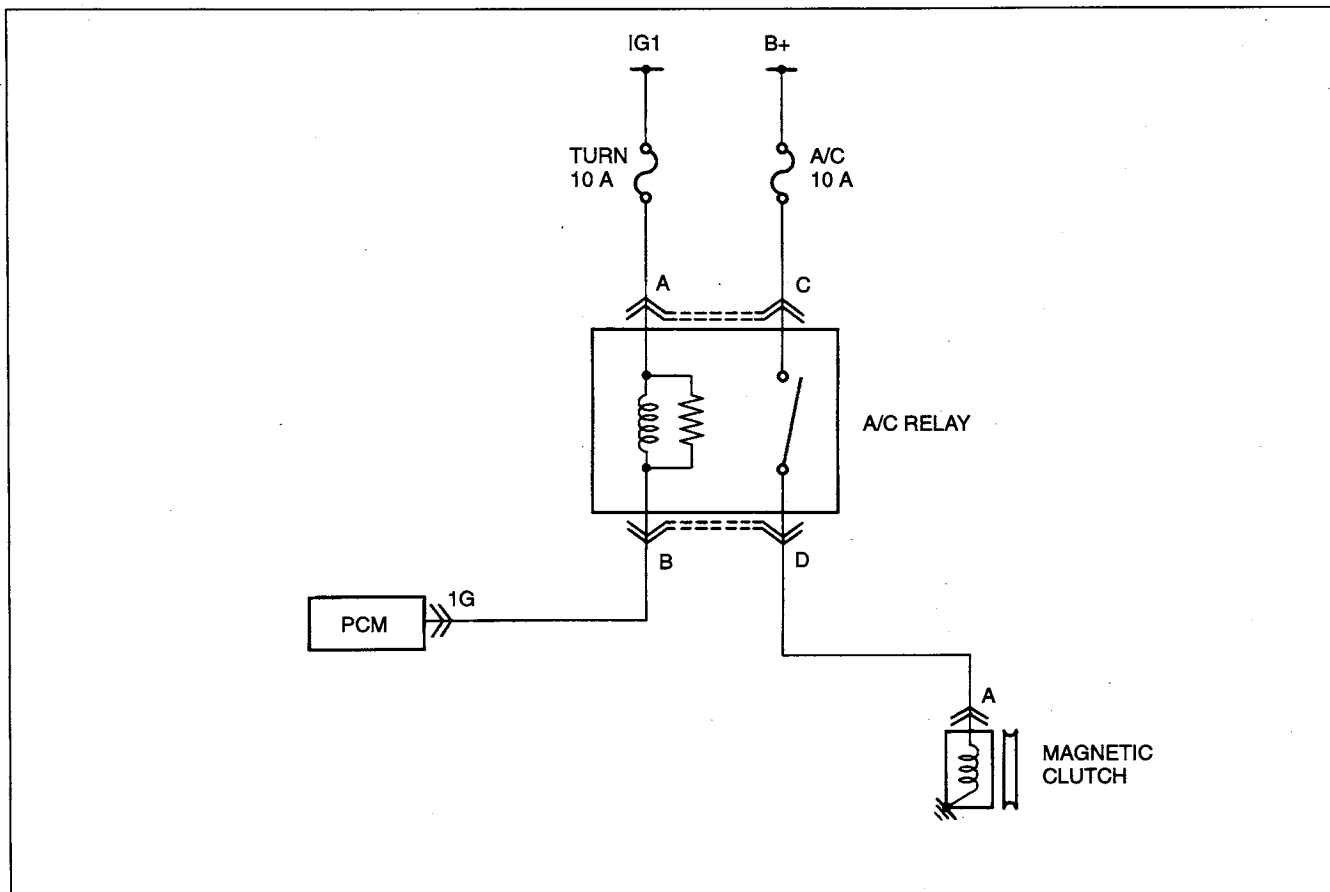

B+: Battery positive voltage

Step	Inspection procedure	Terminal	Result	Action
1	1) Connect jumper wire between terminal B of A/C relay connector and ground. 2) Start engine. 3) Does magnetic clutch operate?	—	YES	Check for continuity between wiring harness of A/C relay and PCM [B—1G], and check PCM (BP ATX, Z5 ATX) (Refer to section F1 or F2)
			NO	Go to Step 2
2	Measure voltage at terminals of A/C relay connector (female).	D	B+	Go to Step 3
			Other	Check terminal C
		C	B+	Check terminal A
			Other	Repair wiring harness [Fuse—A/C relay: A/C 10 A—C]
		A	B+	Replace A/C relay (Refer to page U-31)
			Other	Repair wiring harness [Fuse—A/C relay: TURN 10 A—A]
3	Measure voltage at terminal of magnetic clutch connector (female).	A	B+	Check magnetic clutch (Refer to page U-29)
			Other	Repair wiring harness [A/C relay — Magnetic clutch: D—A]

Flowchart No.	Condenser fan system inspection	Symptom Only condenser fan does not operate
12		Related parts . . . Condenser fan relay, condenser fan, PCM (BP ATX, Z5 ATX), wiring harness

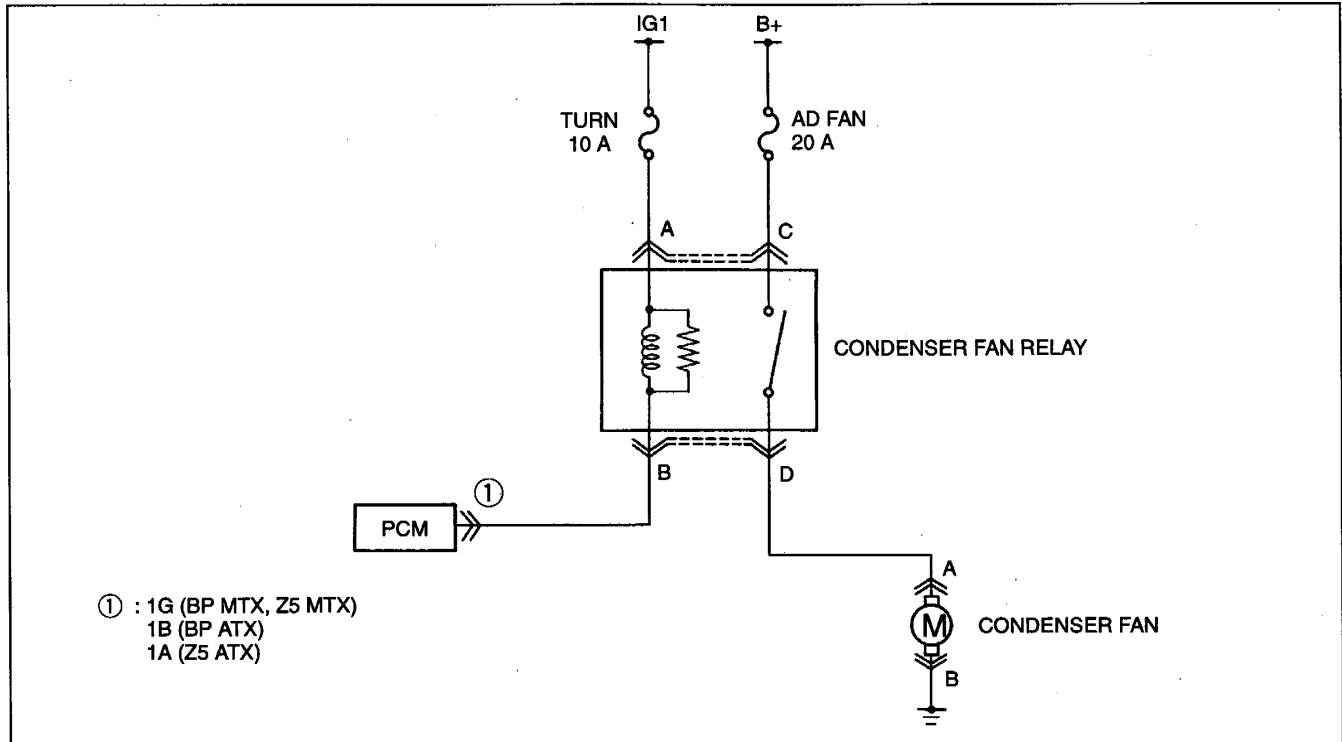

B+: Battery positive voltage

Step	Inspection procedure	Terminal	Result	Action
1	1) Connect jumper wire between terminal B of condenser fan relay connector (female) and ground. 2) Start engine. 3) Does condenser fan operate?	—	YES	Check for continuity between wiring harness of condenser fan relay and PCM [B—1G: BP MTX, Z5 MTX/B—1B: BP ATX/B—1A: Z5 ATX], and check PCM (BP ATX, Z5 ATX) (Refer to section F1 or F2)
			NO	Go to Step 2
2	Measure voltage at terminals of condenser fan relay connector (female).	D	B+	Go to Step 3
			Other	Check terminal C
		C	B+	Check terminal A
			Other	Repair wiring harness [Fuse—Condenser fan relay: AD FAN 30 A—C]
		A	B+	Replace condenser fan relay (Refer to page U-31)
			Other	Repair wiring harness [Fuse—Condenser fan relay: TURN 10 A—A]
3	Measure voltage at terminals of condenser fan connector (female).	A	B+	Check terminal B
			Other	Repair wiring harness [Condenser fan relay—Condenser fan: D—A]
		B	B+	Repair wiring harness [Condenser fan (B)—GND]
			Other	Replace condenser fan (Refer to page U-30)

Flowchart No. 13	Refrigerant system inspection	Symptom Magnetic clutch, condenser fan, and A/C compressor idle-up operate, but cool air does not discharged or air cooling ability is low
		Related parts ... Refrigerant system

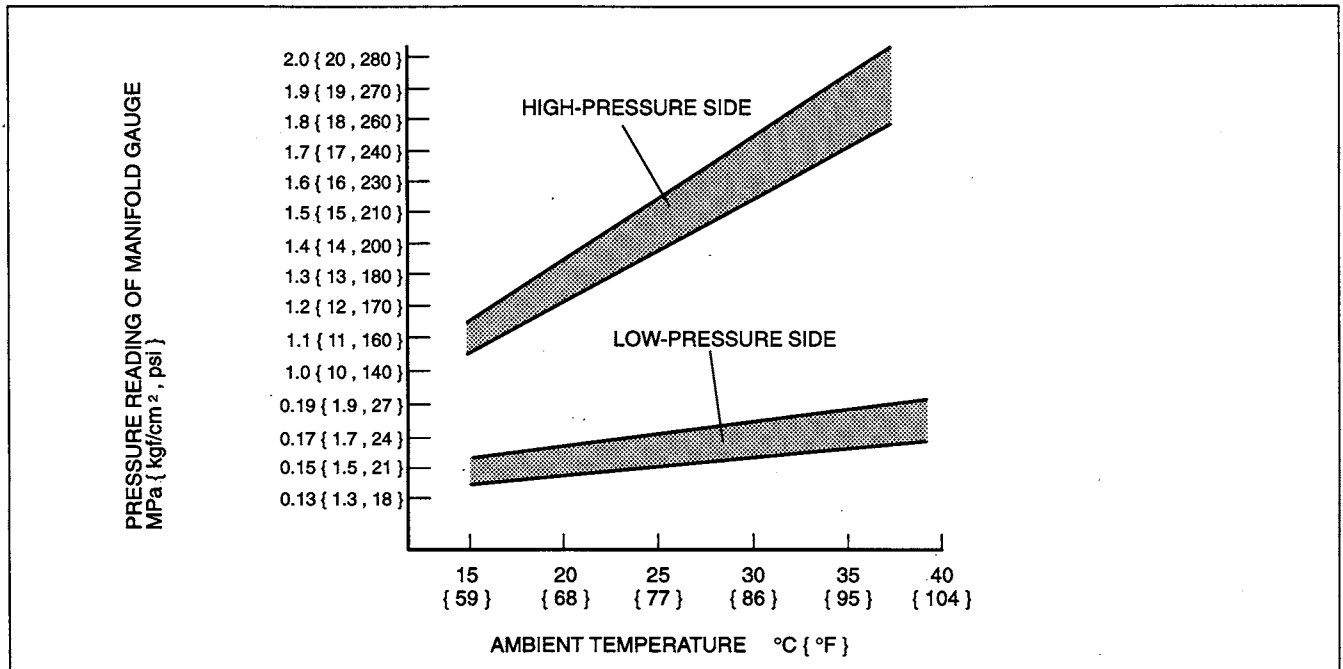

Step	Inspection procedure	Result	Action
1	Conduct refrigerant pressure check. (Refer to page U-9.)	High- and low-pressure-side readings are higher than normal	Go to Step 2
		High- and low-pressure-side readings are lower than normal	Go to Step 3
		High-pressure-side reading is a little lower than normal; low-pressure-side reading is a little higher than normal	Go to Step 4
		High-pressure-side reading rises to normal pressure range and then drops below range; low-pressure-side reading is negative	Go to Step 5
		No difference between high- and low-pressure-side readings	Improper compression of A/C compressor Replace A/C compressor (Refer to page U-20)
2	Are condenser fins clogged or damaged?	YES	Insufficient refrigeration in condenser Clean or repair condenser fins (Refer to page U-21)
		NO	Too much refrigerant Adjust refrigerant amount

Step	Inspection procedure	Result	Action
3	1) Conduct gas leak test. (Refer to page U-8.) 2) Are there any oil stains or gas leaks?	YES	Take a necessary measure, depending on the result of "gas leak test" (Refer to page U-8)
		NO	Insufficient refrigerant due to secular leakage Insufficient charging Regulate refrigerant amount (Refer to page U-6)
4	Is heat-sensing tube in its proper position and securely connected to evaporator outlet pipe? (Refer to page U-19.)	YES	Expansion valve opening too wide because of expansion valve malfunction Replace expansion valve (Refer to page U-18)
		NO	Expansion valve opening too wide because of improper heat-sensing tube installation Reinstall heat-sensing tube (Refer to page U-19)
5	1) Turn off fan switch and wait for about 10 minutes. 2) Set fan switch at 4th. 3) Are pressure readings normal immediately after A/C compressor is turned on?	YES	Expansion valve clogged due to frozen moisture Replace receiver/drier (Refer to page U-22)
		NO	Go to Step 6
6	Is heat-sensing tube in its proper position?	YES	Expansion valve clogged with foreign material Expansion valve closing too wide because of expansion valve malfunction or heat-sensing tube leakage Replace expansion valve (Refer to page U-18)
		NO	Expansion valve closing too wide because of improper heat-sensing tube installation Reinstall heat-sensing tube (Refer to page U-19)

© 1995 Mazda Motor Corporation
Printed in U.S.A.
1495-10-95G

Part No. 9999-95-017B-96